



europaean space agency  
agence spatiale européenne

Pages 1 to 15

**CONTACTS, ELECTRICAL, CRIMP**  
**FOR 3401/060 CONNECTORS,**  
**ESA/SCC Detail Specification No. 3401/061**



**space components  
coordination group**

Issue/Rev.	Date	Approved by	
		SCCG Chairman	ESA Director General or his Deputy
Issue 1	September 1994		
Revision 'A'	May 1995		



ESA/SCC Detail Specification  
No. 3401/061


Rev. 'A'

PAGE 2

ISSUE 1



**DOCUMENTATION CHANGE NOTICE**

Rev. Letter	Rev. Date	Reference	CHANGE Item	Approved DCR No.
'A'	May '95	P1. Cover page P2. DCN P14-15. Table 6	: Editorial corrections	None None 23725

 <b>SCC</b>	ESA/SCC Detail Specification No. 3401/061		PAGE 3 ISSUE 1
---	--	--	-------------------

## TABLE OF CONTENTS

		<u>Page</u>
<b>1.</b>	<b><u>GENERAL</u></b>	<b>5</b>
1.1	Scope	5
1.2	Component Type Variants	5
1.3	Maximum Ratings	5
1.4	Parameter Derating Information	5
1.5	Physical Dimensions	5
<b>2.</b>	<b><u>APPLICABLE DOCUMENTS</u></b>	<b>5</b>
<b>3.</b>	<b><u>TERMS, DEFINITIONS, ABBREVIATIONS, SYMBOLS AND UNITS</u></b>	<b>5</b>
<b>4.</b>	<b><u>REQUIREMENTS</u></b>	<b>10</b>
4.1	General	10
4.2	Deviations from Generic Specification	10
4.2.1	Deviations from Special In-process Controls	10
4.2.2	Deviations from Final Production Tests	10
4.2.3	Deviations from Burn-in and Electrical Measurements	10
4.2.4	Deviations from Qualification Tests	10
4.2.5	Deviations from Lot Acceptance Tests	10
4.3	Mechanical Requirements	10
4.3.1	Dimension Check	10
4.3.2	Weight	10
4.3.3	Contact Capability	10
4.3.4	Contact Retention	10
4.3.5	Mating and Unmating Forces	10
4.3.6	Insert Retention	11
4.3.7	Jackscrew Retention	11
4.3.8	Contact Insertion and Withdrawal Forces	11
4.3.9	Engagement and Separation Forces	11
4.3.10	Oversize Pin Exclusion	11
4.3.11	Probe Damage	11
4.3.12	Solderability	11
4.4	Materials and Finishes	11
4.4.1	Shell	11
4.4.2	Inserts	11
4.4.3	Contacts	11
4.4.4	Contact Retaining Clip	11
4.4.5	Guiding and Locking Devices	11
4.4.6	Magnetism Level	12
4.5	Marking	12
4.5.1	General	12
4.5.2	The SCC Component Number	12
4.5.3	Traceability Information	12
4.6	Electrical Measurements	12
4.6.1	Electrical Measurements at Room Temperature	12
4.6.2	Electrical Measurements at High and Low Temperatures	12
4.6.3	Circuit for Electrical Measurements	12
4.7	Burn-in and Electrical Measurements	12

		<p style="text-align: center;">ESA/SCC Detail Specification No. 3401/061</p>		<p>PAGE 4 ISSUE 1</p>
---	---	--	--	---------------------------

	<u>Page</u>
4.8 Environmental and Endurance Tests	13
4.8.1 Measurements and Inspections on Completion of Environmental Tests	13
4.8.2 Measurements and Inspections at Intermediate Points during Endurance Tests	13
4.8.3 Measurements and Inspections on Completion of Endurance Tests	13
4.8.4 Conditions for Operating Life Tests	13
4.8.5 Electrical Circuits for Operating Life Tests	13
4.8.6 Conditions for High Temperature Storage Test	13

**TABLES**

1(a) Type Variants	6
1(b) Maximum Ratings	7
2 Electrical Measurements at Room Temperature	13
3 Not applicable	N/A
4 Not applicable	N/A
5 Not applicable	N/A
6 Measurements and Inspections on Completion of Environmental and Endurance Tests	14

**FIGURES**

1 Parameter Derating Information	N/A
2 Physical Dimensions:	8
- Variants with Uneven Numbers - Male Contact	8
- Variants with Even Numbers - Female Contact	9

**APPENDICES (Applicable to specific Manufacturers only)**

None.

**1. GENERAL****1.1 SCOPE**

This specification details the ratings, physical and electrical characteristics, test and inspection data for Contacts, Electrical, Crimp, Gauge 22, 20, 16, 12 for 3401/060 Connectors.

These contacts shall be packed separately from the connectors and may be procured either with the connectors or separately.

This specification shall be read in conjunction with:

- ESA/SCC Generic Specification No. 3401, Connectors, Electrical, Non-Filtered, Circular and Rectangular.
- ESA/SCC Detail Specification No. 3401/060, Connectors, Electrical, Rectangular, Multiple Insert Type, Rack and Panel, Removable Crimp Contacts, Based on MIL-C-83527.

the requirements of which are supplemented herein.

**1.2 COMPONENT TYPE VARIANTS**

The different sizes of contacts specified herein, which are also covered by this specification are scheduled in Table 1(a).

**1.3 MAXIMUM RATINGS**

The maximum ratings, which shall not be exceeded at any time during use or storage, applicable to the contacts specified herein, are scheduled in Table 1(b).

**1.4 PARAMETER DERATING INFORMATION (FIGURE 1)**

Not applicable.

**1.5 PHYSICAL DIMENSIONS**

The physical dimensions of the contacts specified herein are shown in Figure 2.

**2. APPLICABLE DOCUMENTS**

The following documents form part of this specification and shall be read in conjunction with it:-

- (a) ESA/SCC Generic Specification No. 3401, Connectors, Electrical, Non-Filtered, Circular and Rectangular.
- (b) ESA/SCC Detail Specification No. 3401/060, Connectors, Electrical, Rectangular, Multiple Insert Type, Rack and Panel, Removable Crimp Contact, Based on MIL-C-83527.

**3. TERMS, DEFINITIONS, ABBREVIATIONS, SYMBOLS AND UNITS**

For the purpose of this specification, the terms, definitions, abbreviations, symbols and units specified in ESA/SCC Basic Specification No. 21300 shall apply.



**SCC**

ESA/SCC Detail Specification

No. 3401/061

PAGE 6

ISSUE 1

**TABLE 1(a) - TYPE VARIANTS**

VAR- IANT	TYPE	MATING END SIZE	CRIMP BARREL SIZE	RATED CUR- RENT	ACCEPT WIRE AWG	MAX WEIGHT g	ENGAGEMENT & SEPARATION			TEST PINS			CONTACT CAPABILITY		CON- TACT RETENT. FORCE MAX	CON- TACT INSERT WITHDR FORCES MAX	PROBE DAMAGE		OVERSIZE PIN EXCL.				
							ENGAG. Max N (1)	SEPAR. Max N (1)	Drop g (3)	DIA mm min.	DIA mm max.	Pick-up g (2)	WEIGHT	MO- MENT N.cm			TEST PIN DIA mm min	TEST PIN DIA mm max	FORCE MAX	TEST PIN DIA mm min	TEST PIN DIA mm max		
01	Male			A		0.14	-	-	-	-	-	-	-	-	45	-	-	-	-	-			
02	Female	22	22	5.0	22 24 26	0.20	-	0.21	-	0.749	-	-	55	-	-	1.4	-	-	-	-			
						-	-	-	-	-	-	-	-	-	45	-	0.75	0.77	-	2.45	0.905	0.907	
03	Male				20	0.21	-	-	-	-	-	-	90	-	67	-	-	-	-	-	-	-	
04	Female	20	20	7.5	22 24	0.37	-	0.21	-	0.991	-	100	-	-	-	5.6	-	-	-	-	-	-	-
						-	-	-	-	-	-	-	-	-	67	-	1.01	1.03	-	3.33	1.180	1.182	
05	Male				16	0.72	-	-	-	-	-	-	112	-	90	-	-	-	-	-	-	-	-
06	Female	16	16	13	18 20	0.82	-	0.56	-	1.562	-	220	-	-	-	22.6	-	-	-	-	-	-	-
						-	-	-	-	-	-	-	-	-	90	-	1.58	1.60	-	5.49	1.738	1.740	
07	Male				12 14	1.20	-	-	-	-	-	-	135	-	112	-	-	-	-	-	-	-	-
08	Female	12	12	23	12 14	1.80	-	0.83	-	2.362	-	250	-	-	-	22.6	-	-	-	-	-	-	-
						-	-	-	-	-	-	-	-	-	112	-	2.38	2.40	-	8.04	2.550	2.552	
						-	-	-	-	-	2.413	100	-	-	-	-	-	-	-	-	-	-	-

**NOTES**

- 1st line, maximum values with maximum diameter test pin, last line with minimum diameter test pin.
- With minimum diameter test pin.
- With maximum diameter test pin.

**TABLE 1(b) - MAXIMUM RATINGS**

No.	CHARACTERISTICS	SYMBOL	MAXIMUM RATINGS	UNIT	REMARKS
1	Rated Current	$I_{CR}$	See Table 1(a)	A	-
2	Operating Temperature Range	$T_{op}$	- 65 to + 200	°C	-
3	Storage Temperature Range	$T_{stg}$	- 65 to + 200	°C	-

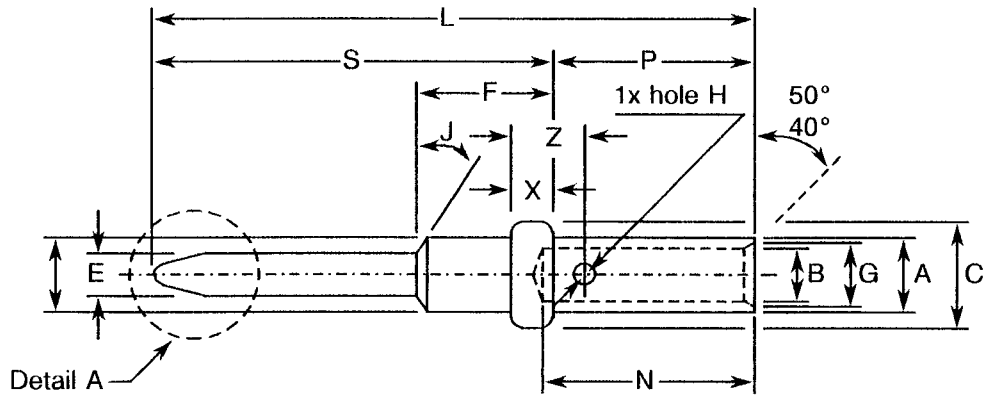
**FIGURE 1 - PARAMETER DERATING INFORMATION**

Not applicable.

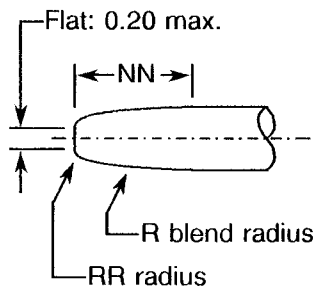


**FIGURE 2 - PHYSICAL DIMENSIONS**

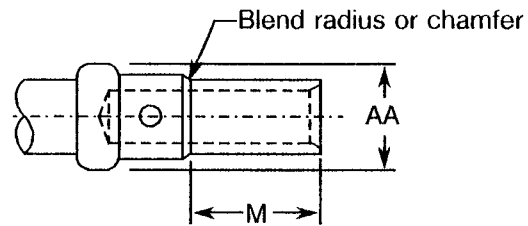
VARIANTS WITH UNEVEN NUMBERS - MALE CONTACT



SHAPE FOR CONTACT SIZES 20 AND 22



DETAIL A



SHAPE FOR CONTACT SIZES 12 AND 16

CONTACT SIZE	ØA	ØB	ØC	ØD	ØE	F	ØG	ØH	J deg. (°)	L	M min.	N
22	1.32	0.95	1.78	1.27	0.79	3.48	1.19	0.56	-	17.58	-	4.19
	1.27	0.86	1.73	1.19	0.74	3.23	1.04	0.46	-	17.20	-	3.43
20	1.73	1.17	2.13	1.83	1.04	4.50	1.47	0.84	50	19.99	-	4.83
	1.65	1.09	2.08	1.75	0.99	4.34	1.32	0.64	40	19.61	-	3.81
16	2.62	1.73	3.40	2.87	1.61	6.12	2.29	1.07	35	24.08	3.81	7.37
	2.57	1.68	3.30	2.79	1.56	5.74	2.03	0.91	25	23.52	3.81	6.35
12	3.84	2.59	4.83	3.84	2.41	6.12	3.56	1.07	35	24.08	3.81	7.37
	3.76	2.49	4.72	3.76	2.36	5.74	3.30	0.91	25	23.52	3.81	6.35

CONTACT SIZE	P	S	X	Z	ØAA	NN	RR
22	6.02	11.56	0.86	4.09	-	1.52	0.25
	5.87	11.33	0.74	3.35	-	1.27	0.10
20	4.19	15.80	0.86	1.75	-	1.78	0.25
	3.94	15.67	0.74	1.37	-	1.27	0.10
16	6.53	17.55	1.22	2.11	2.82	2.54	0.51
	6.22	17.30	1.12	1.75	2.72	1.52	0.25
12	6.53	17.55	1.22	2.11	4.01	2.54	0.51
	6.22	17.30	1.12	1.75	3.94	1.52	0.25

**NOTES**

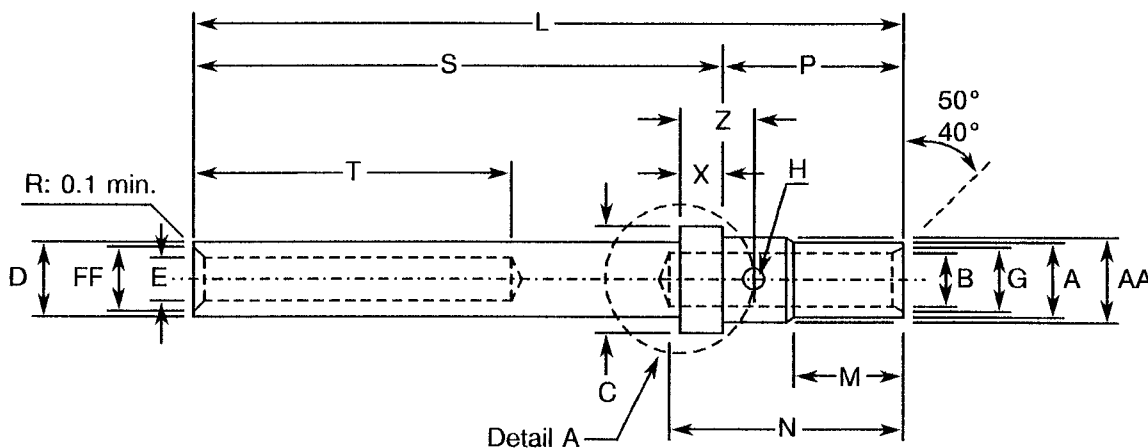
1. All dimensions in millimetres.



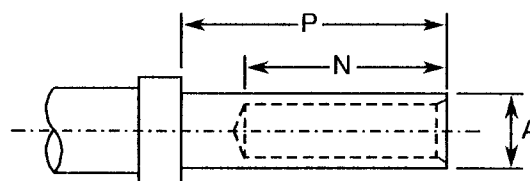
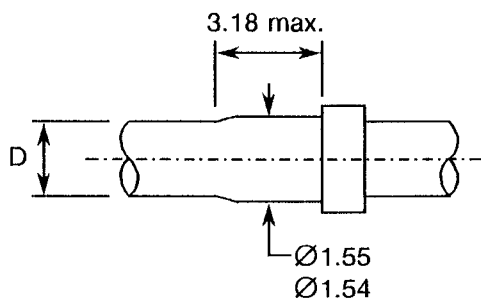


**FIGURE 2 - PHYSICAL DIMENSIONS (CONTINUED)**

VARIANTS WITH EVEN NUMBERS - FEMALE CONTACT



CRIMP BARREL FOR CONTACT SIZES 12 AND 16



CRIMP BARREL FOR CONTACT SIZES 20 AND 22

DETAIL A OPTION FOR SIZE 22 ONLY

CONTACT SIZE	ØA	ØB	ØC	ØD	ØE min.	ØG	ØH	L	M min.	N	P	S
22	1.32	0.95	1.78	1.55	0.79	1.19	0.56	16.51	-	4.19	6.02	10.41
	1.27	0.86	1.73	1.50	-	1.04	0.46	16.00	-	3.43	5.87	10.19
20	1.73	1.17	2.13	1.88	1.05	1.47	0.84	23.32	-	4.83	4.19	19.05
	1.65	1.09	2.08	1.73	-	1.32	0.64	22.81	-	3.81	3.94	18.92
16	2.62	1.73	3.40	2.87	1.63	2.29	1.07	24.77	3.81	7.37	6.53	18.24
	2.57	1.68	3.30	2.69	-	2.03	0.91	24.25	3.81	6.35	6.22	18.03
12	3.84	2.59	4.83	4.09	2.43	3.56	1.07	24.77	3.81	7.37	6.53	18.24
	3.76	2.49	4.72	4.01	-	3.30	0.91	24.25	3.81	6.35	6.22	18.03

CONTACT SIZE	T min.	X	Z	ØAA	FF min.
22	7.11	0.86	4.09	-	1.09
	-	0.74	3.35	-	-
20	8.26	0.86	1.75	-	1.42
	-	0.74	1.37	-	-
16	11.89	1.22	2.11	2.82	2.18
	-	1.12	1.75	2.72	-
12	11.89	1.22	2.11	4.01	2.95
	-	1.12	1.75	3.94	-

**NOTES**

1. All dimensions in millimetres.



#### 4. REQUIREMENTS

##### 4.1 GENERAL

The complete requirements for procurement of the contacts specified herein are stated in this specification and ESA/SCC Generic Specification No. 3401. Deviations from the Generic Specification, applicable to this Detail Specification only, are listed in Para. 4.2.

Deviations from the applicable Generic Specification and this Detail Specification, formally agreed with specific Manufacturers on the basis that the alternative requirements are equivalent to the ESA/SCC requirements and do not affect the components' reliability, are listed in the appendices attached to this specification.

##### 4.2 DEVIATIONS FROM GENERIC SPECIFICATION

###### 4.2.1 Deviations from Special In-process Controls

None.

###### 4.2.2 Deviations from Final Production Tests (Chart II)

(a) Para. 9.5, Magnetism Level: Not applicable.

###### 4.2.3 Deviations from Burn-in and Electrical Measurements (Chart III)

Not applicable.

###### 4.2.4 Deviations from Qualification Tests (Chart IV)

(a) Para. 9.31, Solderability: Not applicable.

###### 4.2.5 Deviations from Lot Acceptance Tests (Chart V)

(a) Para. 9.31, Solderability: Not applicable.

##### 4.3 MECHANICAL REQUIREMENTS

###### 4.3.1 Dimension Check

The dimensions of the contacts specified herein shall be verified in accordance with the requirements set out in Para. 9.6 of ESA/SCC Generic Specification No. 3401 and shall conform to those shown in Figure 2 of this specification.

###### 4.3.2 Weight

The maximum weight of the contacts specified herein shall be as specified in Table 1(a).

###### 4.3.3 Contact Capability


For the purpose of this test, the pick-up and drop weights shall be as specified in Table 1(a).

###### 4.3.4 Contact Retention (in insert)

The contact retention force shall be as specified in Table 1(a).

###### 4.3.5 Mating and Unmating Forces

As specified in ESA/SCC Detail Specification No. 3401/060.

	ESA/SCC Detail Specification No. 3401/061		PAGE 11 ISSUE 1
---	--	--	--------------------

4.3.6 Insert Retention (in Shell)

As specified in ESA/SCC Detail Specification No. 3401/060.

4.3.7 Jackscrew Retention

Not applicable.

4.3.8 Contact Insertion and Withdrawal Forces

The contact insertion and withdrawal forces shall be as specified in Table 1(a).

4.3.9 Engagement and Separation Forces

The diameter of the test pin and the engagement and separation forces of the female contacts shall be as specified in Table 1(a).

4.3.10 Oversize Pin Exclusion

The diameter of the test pin and the force applied to it shall be as specified in Table 1(a).

4.3.11 Probe Damage

The probe diameter and the moment at the end of the probe shall be as specified in Table 1(a).

4.3.12 Solderability

Not applicable.

4.4 MATERIALS AND FINISHES

The materials and finishes shall be as specified herein. Where a definite material is not specified, a material which will enable the connectors specified herein to meet the performance requirements of this specification shall be used. Acceptance or approval of any constituent material does not guarantee acceptance of the finished product.

4.4.1 Shell

As specified in ESA/SCC Detail Specification No. 3401/060.

4.4.2 Inserts

As specified in ESA/SCC Detail Specification No. 3401/060.

4.4.3 Contacts

The contact body shall be made of copper alloy selected from raw materials with a minimum of impurities. It shall be plated as follows:-

- 2.0µm minimum nickel underplate.
- 1.27µm minimum gold plate.

4.4.4 Contact Retaining Clip

As specified in ESA/SCC Detail Specification No. 3401/060.

4.4.5 Guiding and Locking Devices

As specified in ESA/SCC Detail Specification No. 3401/060.



4.4.6 Magnetism Level

Not applicable.

4.5 MARKING

4.5.1 General

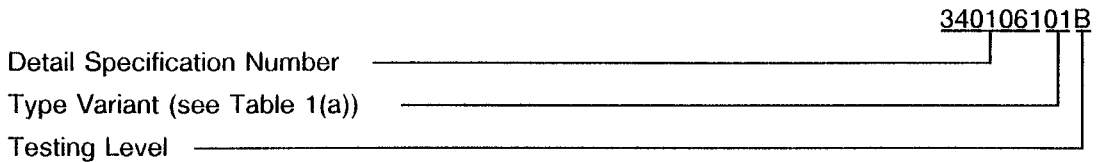
The marking of all components delivered to this specification shall be in accordance with the requirements of ESA/SCC Basic Specification No. 21700 and the following subparagraphs.

These components being too small to accommodate the marking as specified hereafter, the full marking information shall accompany each lot of components in its primary package. Such marking shall comprise:-

- (a) The SCC Component Number.
- (b) Traceability information.

4.5.2 The SCC Component Number

The SCC component number shall be constituted and marked as follows:-



4.5.3 Traceability Information

Traceability information shall be marked in accordance with ESA/SCC Basic Specification No. 21700.

4.6 ELECTRICAL MEASUREMENTS

4.6.1 Electrical Measurements at Room Temperature

The parameters to be measured in respect of electrical characteristics are scheduled in Table 2. Unless otherwise specified these measurements shall be performed at  $T_{amb} = +22 \pm 3 \text{ }^\circ\text{C}$ .

4.6.2 Electrical Measurements at High and Low Temperatures (Table 3)

Not applicable.

4.6.3 Circuit for Electrical Measurements (Figure 4)

Not applicable.

4.7 BURN-IN AND ELECTRICAL MEASUREMENTS (TABLES 4 AND 5)

Not applicable.

**TABLE 2 - ELECTRICAL MEASUREMENTS AT ROOM TEMPERATURE**

No.	CHARACTERISTICS	SYMBOL	ESA/SCC No. 3401 TEST METHOD	TEST CONDITION	VARIANTS	LIMITS		UNIT	
						MIN.	MAX.		
1	Contact Resistance (Low Level Current)	Rcl	Para 9.1.1.3	Para 9.1.1.3	01-02	-	8.0	mΩ	
					03-04	-	7.0		
					05-06	-	3.8		
					07-08	-	1.8		
2	Contact Resistance (Rated Current)	Rcr	Para 9.1.1.3	Para 9.1.1.3				mΩ	
					5.0A	01-02	-		5.6
					7.5A	03-04	-		2.8
					13A	05-06	-		2.0
					23A	07-08	-		1.3

**TABLES 3, 4 AND 5**

Not applicable.

4.8 ENVIRONMENTAL AND ENDURANCE TESTS (CHARTS IV AND V OF ESA/SCC GENERIC SPECIFICATION NO. 3401)

4.8.1 Measurements and Inspections on Completion of Environmental Tests

The parameters to be measured and inspections to be performed on completion of environmental testing shall be those specified in Table 6. Unless otherwise specified, the measurements shall be performed at  $T_{amb} = +22 \pm 3$  °C.

4.8.2 Measurements and Inspections at Intermediate Points during Endurance Tests.

Not applicable.

4.8.3 Measurements and Inspections on Completion of Endurance Tests

The parameters to be measured and inspections to be performed on completion of endurance tests shall be those specified in Table 6. Unless otherwise specified, the measurements shall be performed at  $T_{amb} = +22 \pm 3$  °C.

4.8.4 Conditions for Operating Life Tests (Part of Endurance Testing)

Not applicable.

4.8.5 Electrical Circuits for Operating Life Tests

Not applicable.

4.8.6 Conditions for High Temperature Storage Test (Part of Endurance Testing)

The requirements for the high temperature storage test are specified in Section 9 of ESA/SCC Generic Specification No. 3401. The conditions for high temperature storage testing shall be the maximum storage temperature specified in Table 1(b) of this specification.



**SCC**

ESA/SCC Detail Specification  
No. 3401/061

Rev. 'A'

PAGE 14

ISSUE 1

**TABLE 6 - MEASUREMENTS AND INSPECTIONS ON COMPLETION OF ENVIRONMENTAL AND ENDURANCE TESTS**

NO.	ESA/SCC GENERIC NO. 3401		MEASUREMENTS AND INSPECTIONS		SYMBOL	LIMITS		UNIT
	ENVIRONMENTAL AND ENDURANCE TESTS (1)	TEST METHOD AND CONDITIONS	IDENTIFICATION	CONDITIONS		MIN	MAX	
01	Wiring	Para. 9.10 & Table 1(a) of this spec.	Low Level Contact Resistance	Table 2 Item 1	Rcl	Table 2 Item 1		
02	Vibration	Para. 9.11	ESA/SCC 3401/060					
03	Shock or Bump	Para. 9.12	ESA/SCC 3401/060					
04	Climatic Sequence	Para. 9.13	ESA/SCC 3401/060					
05	Seal Test	Para. 9.9	ESA/SCC 3401/060					
06	Plating Thickness	Para. 9.14	Thickness	-	-	Para. 4.4.3 of this spec		
07	Joint Strength	Para. 9.15	ESA/SCC 3401 Para 9.15					
08	Rapid Change of Temperature	Para. 9.16	ESA/SCC 3401/060					
09	Contact Retention (in insert)	Para. 9.17 & Para. 4.3.4 of this spec.	Contact Displacement		-	ESA/SCC 3401 Para. 9.17		
10	Endurance	Para. 9.18	<b>Initial</b> Low Level Contact Resist	Table 2 Item 1	Rcl	Record Values		mΩ
			<b>Final</b> Low Level Contact Resistance Drift	Table 2 Item 1	ΔRcl	-	3.0	
11	Permanence of Marking	Para. 9.19	As applicable					
12	Mating/Unmating Forces	Para. 9.20	ESA/SCC 3401/060					
13	High Temperature Storage	Para. 9.21	<b>Initial</b> Low Level Contact Resist	Table 2 Item 1	Rcl	Record Values		mΩ
			<b>Final</b> Low Level Contact Resistance Drift	Table 2 Item 1	ΔRcl	-	3.0	
			Rated Current Contact Resistance	Table 2 Item 2	Rcr	Table 2 Item 2		
			Contact Retention (in insert)	Para. 4.3.4 of this spec.	-	ESA/SCC 3401 Para. 9.17		
14	Corrosion	Para. 9.22	Visual Examination					

**NOTES**

1. The tests in this table refer to either Chart IV or V and shall be used as applicable.



**TABLE 6 - MEASUREMENTS AND INSPECTIONS ON COMPLETION OF ENVIRONMENTAL AND ENDURANCE TESTS (CONTINUED)**

NO.	ESA/SCC GENERIC NO. 3401		MEASUREMENTS AND INSPECTIONS		SYMBOL	LIMITS		UNIT
	ENVIRONMENTAL AND ENDURANCE TESTS (1)	TEST METHOD AND CONDITIONS	IDENTIFICATION	CONDITIONS		MIN	MAX	
15	Insert Retention (in shell)	Para. 9.23 & Para. 4.3.6 of this spec.	ESA/SCC 3401/060					
16	Jackscrew Retention	Para. 9.24 & Para. 4.3.7 of this spec.	ESA/SCC 3401/060					
17	High Temperature Measurements	Para. 9.25	ESA/SCC 3401/060					
18	Overload Test	Para. 9.26	Rated Current Contact Resistance	Table 2 Item 2	Rcr	Table 2 Item 2		
19	Maintenance Aging	Para. 9.27	Visual Examination Contact Retention  Contact Insertion & Withdrawal Forces	- Para. 4.3.4 of this spec. Para. 4.3.8 of this spec.	- - -	- - ESA/SCC 3401 Para. 9.17 Para. 4.3.8		
20	Engage/Separation Forces	Para. 9.28 & Para. 4.3.9 of this spec.	Force		-	Para. 4.3.9		
21	Oversize Pin Exclusion	Para. 9.29 & Para. 4.3.10 of this spec.			-	ESA/SCC 3401 Para. 9.29		
22	Probe Damage	Para. 9.30 & Para. 4.3.11 of this spec.	Contact Separation Force	Para. 4.3.9 of this spec.	-	Para. 4.3.9		
23	Solderability	Para. 9.31 & Para. 4.3.12 of this spec.	Not applicable					

**NOTES**

1. The tests in this table refer to either Chart IV or V and shall be used as applicable.