



europaean space agency  
agence spatiale européenne

Pages 1 to 12

**ACCESSORIES FOR CIRCULAR  
CONNECTORS**

**3401/044, 3401/052 AND 3401/056**

**ESA/SCC Detail Specification No. 3401/062**



**space components  
coordination group**

Issue/Rev.	Date	Approved by	
		SCCG Chairman	ESA Director General or his Deputy
Issue 1	September 1994	<i>Pommes</i>	<i>Pommes</i>
Revision 'A'	September 1998	<i>Sam Mitt</i>	<i>pp. Riaschi</i>
Revision 'B'	November 2000	<i>Sam Mitt</i>	<i>Pommes</i>



**DOCUMENTATION CHANGE NOTICE**

Rev. Letter	Rev. Date	Reference	CHANGE Item	Approved DCR No.
'A'	Sept. '98	P1. Cover page P2. DCN P12. Para. 4.4.1 : Plating amended		None None 221488
'B'	Nov. '00	P1. Cover page P2. DCN P7. Table 1(a) : Variants 65, 66 and 67 added : Weights for Variants 56 to 67 added P10. Figure 2(f) : Figure added P10A. : Page added Figure 2(g) : Figure added Figure 2(h) : Figure added		None None 221573 23925 221573 None 221573 221573

**SCC**ESA/SCC Detail Specification  
No. 3401/062

PAGE 3

ISSUE 1

**TABLE OF CONTENTS**

	<u>Page</u>
<b>1. <u>GENERAL</u></b>	<b>4</b>
1.1 Scope	4
1.2 Component Type Variants	4
1.3 Maximum Ratings	4
1.4 Parameter Derating Information	4
1.5 Physical Dimensions	4
1.6 Functional Diagram	4
<b>2. <u>APPLICABLE DOCUMENTS</u></b>	<b>4</b>
<b>3. <u>TERMS, DEFINITIONS, ABBREVIATIONS, SYMBOLS AND UNITS</u></b>	<b>4</b>
<b>4. <u>REQUIREMENTS</u></b>	<b>11</b>
4.1 General	11
4.2 Deviations from Generic Specification	11
4.2.1 Deviations from Special In-process Controls	11
4.2.2 Deviations from Final Production Tests	11
4.2.3 Deviations from Screening Tests	11
4.2.4 Deviations from Qualification Tests	11
4.2.5 Deviations from Lot Acceptance Tests	11
4.3 Mechanical Requirements	11
4.3.1 Dimension Check	11
4.3.2 Weight	11
4.4 Materials and Finishes	12
4.4.1 Accessories	12
4.4.2 Screws and Washers	12
4.4.3 Magnetism Level	12
4.5 Marking	12
4.5.1 General	12
4.5.2 The SCC Component Number	12
4.6 Electrical Measurements	12
4.7 Burn-in and Electrical Measurements	12
4.8 Environmental and Endurance Tests	12

**TABLES**

1(a) Type Variants	5
1(b) Maximum Ratings	7

**FIGURES**

1 Not Applicable	
2 Physical Dimensions	8
2(a) Nut	8
2(b) Straight Cable Clamp	8
2(c) 90° Cable Clamp	9
2(d) Termination and Backshell	9
2(e) 45° Cable Clamp	

**APPENDICES (Applicable to specific Manufacturers only)**

None.

 <b>SCC</b>	ESA/SCC Detail Specification No. 3401/062	-	PAGE 4 ISSUE 1
---	--	---	-------------------

**1. GENERAL**

**1.1 SCOPE**

This specification details the ratings, physical and electrical characteristics, test and inspection data for Accessories for Circular Connectors 3401/044, 3401/052 and 3401/056. It shall be read in conjunction with ESA/SCC Generic Specification No. 3401, the requirements of which are supplemented herein and ESA/SCC Detail Specifications Nos. 3401/044, 3401/052 and 3401/056.

**1.2 COMPONENT TYPE VARIANTS**

The type variants of accessories covered by this specification are given in Table 1(a).

**1.3 MAXIMUM RATINGS**

The maximum ratings, which shall not be exceeded at any time during use or storage, applicable to the accessories specified herein, are given in Table 1(b).

**1.4 PARAMETER DERATING INFORMATION (FIGURE 1)**

Not applicable.

**1.5 PHYSICAL DIMENSIONS**

The physical dimensions of the accessories specified herein are shown in Figure 2.

**1.6 FUNCTIONAL DIAGRAM**

Not applicable.

**2. APPLICABLE DOCUMENTS**

The following documents form part of this specification and shall be read in conjunction with it:-

- (a) ESA/SCC Generic Specification No. 3401 for Connectors, Electrical, Non-filtered, Circular and Rectangular.
- (b) ESA/SCC Detail Specification No. 3401/044 for Connectors, Electrical, Circular Bayonet Coupling, Removable Crimp Contacts, Based on MIL-C-38999 Series II.
- (c) ESA/SCC Detail Specification No. 3401/052 for Connectors, Electrical, Circular Bayonet Coupling, Scoop-proof, Removable Crimp Contacts, Based on MIL-C-38999 Series I.
- (d) ESA/SCC Detail Specification No. 3401/056 for Connectors, Electrical, Circular, Triple Start Self-locking Coupling, Scoop-proof, Removable Crimp Contacts, Based on MIL-C-38999 Series III.

**3. TERMS, DEFINITIONS, ABBREVIATIONS, SYMBOLS AND UNITS**

For the purpose of this specification, the terms, definitions, abbreviations, symbols and units specified in ESA/SCC Basic Specification No. 21300 shall apply.

**TABLE 1(a) - TYPE VARIANTS**

VARIANT	BACKSHELL DESCRIPTION	FOR CONNECTORS	SHELL SIZE	TIGHTENING TORQUE Nm Max	WEIGHT (g) Max
01	Nut	/052 (Series I)	09	11.3	4.5
		/044 (Series II)	08	5.6	4.5
02	Nut	/052 (Series I)	11	11.3	5.5
		/044 (Series II)	10	5.6	5.5
03	Nut	/052 (Series I)	13	17.0	6.5
		/044 (Series II)	12	5.6	6.5
04	Nut	/052 (Series I)	15	17.0	7.5
		/044 (Series II)	14	5.6	7.5
05	Nut	/052 (Series I)	17	22.6	9.0
		/044 (Series II)	16	5.6	9.0
06	Nut	/052 (Series I)	19	22.6	10.5
		/044 (Series II)	18	5.6	10.5
07	Nut	/052 (Series I)	21	28.3	12.0
		/044 (Series II)	20	11.3	12.0
08	Nut	/052 (Series I)	23	28.3	13.7
		/044 (Series II)	22	11.3	13.7
09	Nut	/052 (Series I)	25	28.3	15.5
		/044 (Series II)	24	11.3	15.5
10	Straight Cable Clamp	/052 (Series I)	09	11.3	9.2
		/044 (Series II)	08	5.6	9.2
11	Straight Cable Clamp	/052 (Series I)	11	11.3	12.5
		/044 (Series II)	10	5.6	12.5
12	Straight Cable Clamp	/052 (Series I)	13	17.0	15.8
		/044 (Series II)	12	5.6	15.8
13	Straight Cable Clamp	/052 (Series I)	15	17.0	19.2
		/044 (Series II)	14	5.6	19.2
14	Straight Cable Clamp	/052 (Series I)	17	22.6	22.6
		/044 (Series II)	16	5.6	22.6
15	Straight Cable Clamp	/052 (Series I)	19	22.6	26.0
		/044 (Series II)	18	5.6	26.0
16	Straight Cable Clamp	/052 (Series I)	21	28.3	29.5
		/044 (Series II)	20	11.3	29.5
17	Straight Cable Clamp	/052 (Series I)	23	28.3	33.0
		/044 (Series II)	22	11.3	33.0
18	Straight Cable Clamp	/052 (Series I)	25	28.3	36.5
		/044 (Series II)	24	11.3	36.5
19	90° Cable Clamp	/052 (Series I)	09	11.3	10.5
		/044 (Series II)	08	5.6	10.5
20	90° Cable Clamp	/052 (Series I)	11	11.3	13.0
		/044 (Series II)	10	5.6	13.0
21	90° Cable Clamp	/052 (Series I)	13	17.0	15.5
		/044 (Series II)	12	5.6	15.5
22	90° Cable Clamp	/052 (Series I)	15	17.0	18.0
		/044 (Series II)	14	5.6	18.0

**SCC**

ESA/SCC Detail Specification

No. 3401/062

PAGE 6

ISSUE 1

**TABLE 1(a) - TYPE VARIANTS (CONTINUED)**

VARIANT	BACKSHELL DESCRIPTION	FOR CONNECTORS	SHELL SIZE	TIGHTENING TORQUE Nm Max	WEIGHT (g) Max
23	90° Cable Clamp	/052 (Series I)	17	22.6	21.5
		/044 (Series II)	16	5.6	21.5
24	90° Cable Clamp	/052 (Series I)	19	22.6	25.0
		/044 (Series II)	18	5.6	25.0
25	90° Cable Clamp	/052 (Series I)	21	28.3	29.2
		/044 (Series II)	20	11.3	29.2
26	90° Cable Clamp	/052 (Series I)	23	28.3	33.5
		/044 (Series II)	22	11.3	33.5
27	90° Cable Clamp	/052 (Series I)	25	28.3	38.0
		/044 (Series II)	24	11.3	38.0
28	Nut	/056 (Series III)	09	11.3	5.0
29			11	11.3	6.0
30			13	17.0	7.0
31			15	17.0	8.0
32			17	22.6	9.5
33			19	22.6	11.5
34			21	28.3	12.5
35			23	28.3	14.5
36			25	28.3	17.0
37	Straight Cable Clamp	/056 (Series III)	09	11.3	9.2
38			11	11.3	12.5
39			13	17.0	15.8
40			15	17.0	19.2
41			17	22.6	22.6
42			19	22.6	26.0
43			21	28.3	29.5
44			23	28.3	33.0
45			25	28.3	36.5
46	90° Cable Clamp	/056 (Series III)	09	11.3	10.5
47			11	11.3	13.0
48			13	17.0	15.5
49			15	17.0	18.0
50			17	22.6	21.5
51			19	22.6	25.0
52			21	28.3	29.2
53			23	28.3	33.5
54			25	28.3	38.0
55	Shield Termination and Cable Clamp	/056 (Series III)	17	22.6	44.0

**SCC**ESA/SCC Detail Specification  
No. 3401/062

Rev. 'B'

PAGE 7

ISSUE 1

**TABLE 1(a) - TYPE VARIANTS (CONTINUED)**

VARIANT	BACKSHELL DESCRIPTION	FOR CONNECTORS	SHELL SIZE	TIGHTENING TORQUE Nm Max	WEIGHT (g) Max
56	45° Cable Clamp	/056 (Series III)	09	11.3	12
57			11	11.3	13.5
58			13	17.0	16.5
59			15	17.0	20
60			17	22.6	23
61			19	22.6	28
62			21	28.3	32.5
63			23	28.3	35.5
64			25	28.3	41
65	Straight Short Termination, Size 9	/056 (Series III)	09	3.0	11.5
66	Straight Shield Termination, Size 9	/056 (Series III)	09	3.0	12
67	90° Shield Termination, Size 9	/056 (Series III)	09	3.0	13

**TABLE 1(b) - MAXIMUM RATINGS**

NO.	CHARACTERISTIC	SYMBOL	MAXIMUM RATING	UNIT
1	Operating Temperature Range	$T_{op}$	- 65 to + 200	°C
2	Storage Temperature Range	$T_{stg}$	- 65 to + 200	°C
3	Tightening Torque	$T_q$	See Table 1(a)	-



**FIGURE 2 - PHYSICAL DIMENSIONS**

**FIGURE 2(a) - NUT**

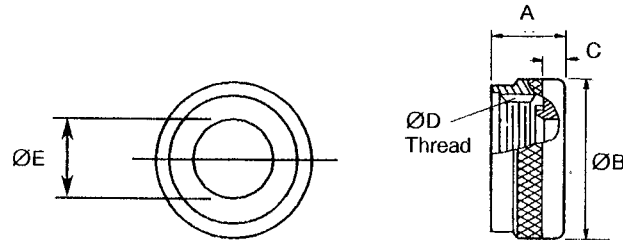

Sizes	A Max		ØB Max		C Max	ØD		ØE Min
	(1)	(2)	(1)	(2)		(1) UNEF-2B	(2)	
08/09	13.70	16.80	19.10	21.79	6.60	0.4375-28	M12 x 1-6H	6.7
10/11	13.70	16.80	21.50	24.99	6.60	0.5625-24	M15 x 1-6H	9.9
12/13	13.70	16.80	25.40	29.39	6.60	0.6875-24	M18 x 1-6H	12.8
14/15	13.70	16.80	27.90	32.49	6.60	0.8125-20	M22 x 1-6H	16.0
16/17	13.70	16.80	31.80	35.71	6.60	0.9375-20	M25 x 1-6H	19.2
18/19	13.70	16.80	35.60	38.50	6.60	1.0625-18	M28 x 1-6H	21.4
20/21	13.70	16.80	38.10	41.70	6.60	1.1875-18	M31 x 1-6H	24.6
22/23	13.70	16.80	41.90	44.91	6.60	1.3125-18	M34 x 1-6H	27.7
24/25	13.70	16.80	44.50	47.98	6.60	1.4375-18	M37 x 1-6H	30.9

**NOTES**

1. Variants 01 to 09.
2. Variants 28 to 36.

**FIGURE 2(b) - STRAIGHT CABLE CLAMP**

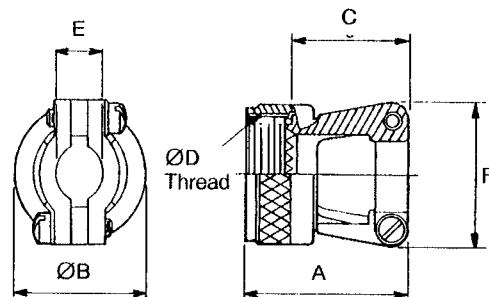

Sizes	A Max		ØB Max		C Max	ØD		E		F Max
	(1)	(2)	(1)	(2)		(1) UNEF-2B	(2)	Min	Max	
08/09	27.50	27.90	19.10	21.79	23.10	0.4375-28	M12 x 1-6H	2.49	5.94	21.60
10/11	27.90	27.90	21.50	24.99	23.10	0.5625-24	M15 x 1-6H	3.87	5.94	22.90
12/13	30.50	30.50	25.40	29.39	25.70	0.6875-24	M18 x 1-6H	4.83	8.33	27.90
14/15	31.80	31.80	27.90	32.49	26.90	0.8125-20	M22 x 1-6H	6.60	11.61	29.20
16/17	34.30	34.30	31.80	35.71	29.50	0.9375-20	M25 x 1-6H	7.19	15.60	33.50
18/19	40.60	40.60	35.60	38.50	35.80	1.0625-18	M28 x 1-6H	8.26	16.10	38.10
20/21	43.20	43.20	38.10	41.70	38.40	1.1875-18	M31 x 1-6H	8.71	17.73	40.60
22/23	47.00	47.00	41.90	44.91	42.20	1.3125-18	M34 x 1-6H	9.68	20.90	43.20
24/25	49.50	49.50	44.50	47.98	47.70	1.4375-18	M37 x 1-6H	10.62	21.67	45.70

**NOTES**

1. Variants 10 to 18.
2. Variants 37 to 45.





**FIGURE 2 - PHYSICAL DIMENSIONS (CONTINUED)**

**FIGURE 2(c) - 90° CABLE CLAMP**

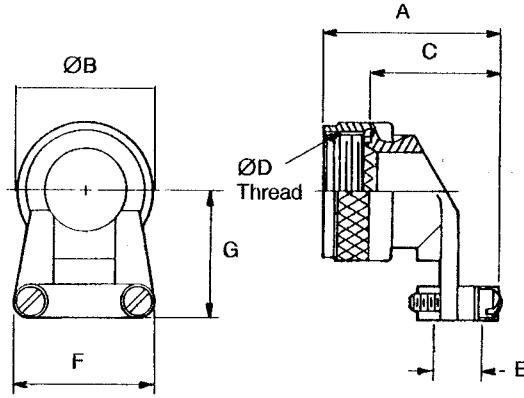

Sizes	A Max		ØB Max		C Max		ØD		E		F Max	G Max
	(1)	(2)	(1)	(2)	(1)	(2)	(1) UNEF-2B	(2)	Min	Max		
08/09	35.10	30.50	21.79	19.10	29.50	25.70	0.4375-28	M12 x 1-6H	2.49	5.94	21.60	25.40
10/11	35.10	30.50	24.99	21.60	29.50	25.70	0.5625-24	M15 x 1-6H	3.87	5.94	22.90	27.90
12/13	37.10	35.60	29.39	25.40	31.50	30.70	0.6875-24	M18 x 1-6H	4.83	8.33	27.90	27.90
14/15	41.40	36.80	32.40	27.90	35.80	32.00	0.8125-20	M22 x 1-6H	6.60	11.61	29.20	31.80
16/17	45.70	40.60	35.71	31.80	40.10	35.80	0.9375-20	M25 x 1-6H	7.19	15.60	33.50	33.00
18/19	46.20	43.20	38.50	35.60	40.60	38.40	1.0625-18	M28 x 1-6H	8.26	16.10	38.10	38.10
20/21	48.30	47.00	41.70	38.10	42.70	42.20	1.1875-18	M31 x 1-6H	8.71	17.73	40.60	40.60
22/23	51.10	49.50	44.91	41.90	46.20	44.70	1.3125-18	M34 x 1-6H	9.68	20.90	43.20	44.50
24/25	54.60	53.30	47.98	44.50	49.00	48.50	1.4375-18	M37 x 1-6H	10.62	21.67	45.70	47.00

**NOTES**

1. Variants 19 to 27.
2. Variants 46 to 54.

**FIGURE 2(d) - TERMINATION AND BACKSHELL**

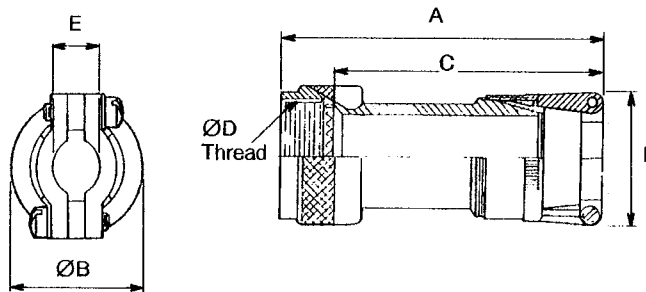

Sizes	A Max	ØB Max	C Max	ØD	E		F Max
					Min	Max	
17	77	31.80	71.40	M25 x 1-6H	6.40	9.50	27.90



**FIGURE 2 - PHYSICAL DIMENSIONS (CONTINUED)**

**FIGURE 2(e) - 45° CABLE CLAMP**

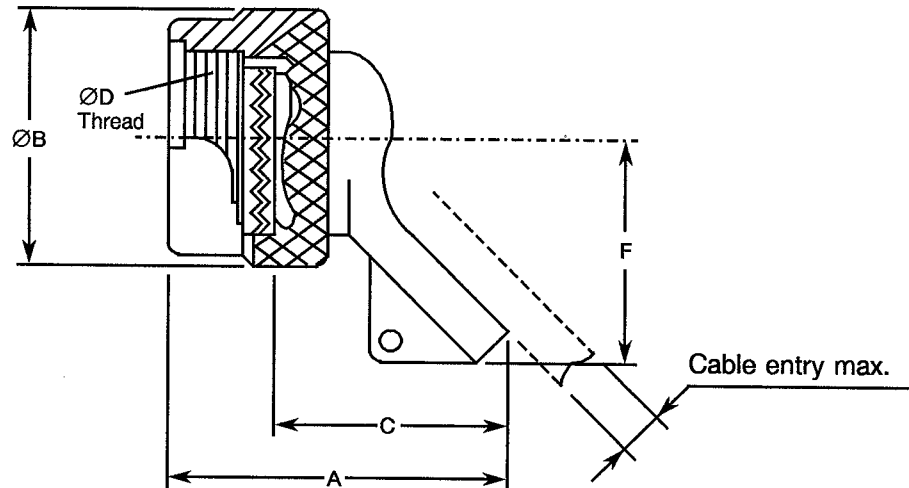

Sizes	A Max	ØB Max	C Max	ØD	Cable entry Max	F Max
09	36.3	19.40	26.2	M12 x 1-6H	6.71	22.4
11	36.3	21.60	26.2	M15 x 1-6H	9.96	22.4
13	36.3	25.40	26.2	M18 x 1-6H	12.85	23.9
15	49.0	27.90	27.7	M22 x 1-6H	16.03	31.8
17	49.0	31.80	28.2	M25 x 1-6H	19.20	33.3
19	51.6	35.60	30.7	M28 x 1-6H	21.46	35.1
21	53.1	38.10	32.0	M31 x 1-6H	24.64	38.1
23	53.1	41.90	33.0	M34 x 1-6H	27.89	42.9
25	56.9	44.50	34.0	M37 x 1-6H	30.99	44.5

**FIGURE 2(f) - STRAIGHT SHORT TERMINATION SIZE 9**

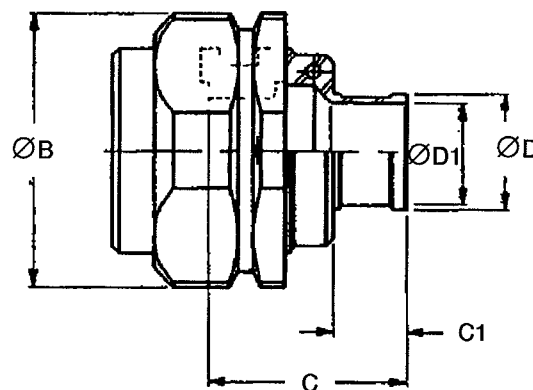

ØB Max	C Max	C1 Max	ØD Max	ØD1 Max
20 (1)	14.5	5.5	8.5	7.0

**NOTES**

1. 17mm across flats.



**FIGURE 2 - PHYSICAL DIMENSIONS (CONTINUED)**

**FIGURE 2(g) - STRAIGHT SHIELD TERMINATION SIZE 9**

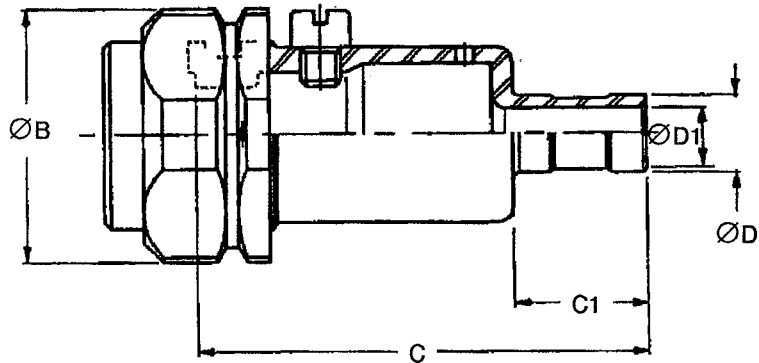

ØB Max	C Max	C1 Max	ØD Max	ØD1	
				Min	Max
20 (1)	34.5	10.5	7.0	4.0	4.5

**NOTES**

1. 17mm across flats.

**FIGURE 2(h) - 90° SHIELD TERMINATION SIZE 9**

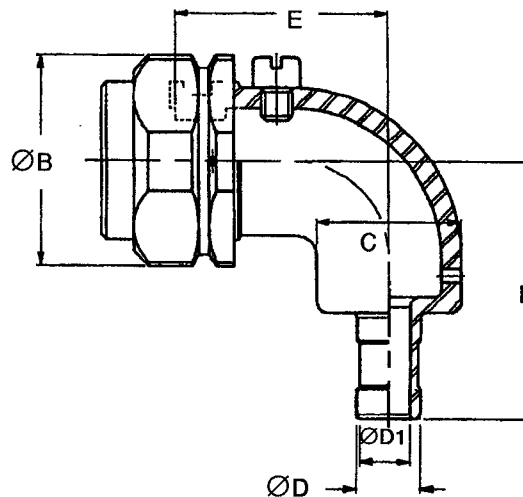

ØB Max	C Max	ØD Max	ØD1		E Max	F Max
			Min	Max		
20 (1)	14	7.0	4.0	4.5	20.5	24.5

**NOTES**

1. 17mm across flats.

**4. REQUIREMENTS****4.1 GENERAL**

The complete requirements for procurement of the accessories specified herein are stated in this specification and ESA/SCC Generic Specification No. 3401 for Connectors, Electrical, Circular and Rectangular. Deviations from the Generic Specification, applicable to this specification only, are listed in Para. 4.2

Deviations from the applicable Generic Specification and this Detail Specification, formally agreed with the specific Manufacturers on the basis that the alternative requirements are equivalent to the ESA/SCC requirements and do not affect the components' reliability, are listed in the appendices attached to this specification.

**4.2 DEVIATIONS FROM GENERIC SPECIFICATION****4.2.1 Deviations from Special In-process Controls**

None.

**4.2.2 Deviations from Final Production Tests (Chart II)**

(a) Para. 9.5, Magnetism Level: Not applicable.

**4.2.3 Deviations from Screening Tests (Chart III)**

Not applicable.

**4.2.4 Deviations from Qualification Tests (Chart IV)**

Not applicable.

**4.2.5 Deviations from Lot Acceptance Tests (Chart V)**

Not applicable.

**4.3 MECHANICAL REQUIREMENTS****4.3.1 Dimension Check**

The dimensions of the accessories specified herein shall be verified in accordance with the requirements set out in Para. 9.5 of ESA/SCC Generic Specification No. 3401 and in Para. 4.2.2 of this specification. They shall conform to those shown in Figure 2 of this specification.

**4.3.2 Weight**

The maximum weight of the accessories specified herein shall be as shown in Table 1(a) of this specification.

4.4 MATERIALS AND FINISHES

The materials and finishes shall be as specified herein. Where a definite material is not specified, a material which will enable the accessories specified herein to meet the performance requirements of this specification shall be used. Acceptance or approval of any constituent material does not guarantee acceptance of the finished product.

4.4.1 Accessories

The accessory elements shall be made of aluminium alloy, dull low-reflective electroless nickel plated.

4.4.2 Screws and Washers

The screws and washers shall be made of passivated stainless steel.

4.4.3 Magnetism Level

Not applicable.

4.5 MARKING

4.5.1 General

The marking of all components delivered to this specification shall be in accordance with the requirements of ESA/SCC Basic Specification No. 21700 and the following paragraphs. Each component shall be marked in respect of:-

- (a) The SCC Component Number.
- (b) Traceability Information.

4.5.2 The SCC Component Number

Each component shall bear the SCC Component Number which shall be constituted and marked as follows:

Detail Specification Number		340106201B
Type Variant (see Table 1(a))		
Testing Level		

The SCC marking information shall accompany each component in its primary package.

4.6 ELECTRICAL MEASUREMENTS (TABLES 2 AND 3)

Not applicable.

4.7 BURN-IN AND ELECTRICAL MEASUREMENTS (TABLES 4 AND 5)

Not applicable.

4.8 ENVIRONMENTAL AND ENDURANCE TESTS (TABLE 6)

Not applicable.

**TABLES 2, 3, 4, 5 AND 6**

Not applicable.