



europaean space agency
agence spatiale européenne

Pages 1 to 39

**CONNECTORS AND SAVERS, ELECTRICAL,
RECTANGULAR, NON-REMOVABLE PCB CONTACTS,
BASED ON TYPE MHD
ESA/SCC Detail Specification No. 3401/065**



**space components
coordination group**

Issue/Rev.	Date	Approved by	
		SCCG Chairman	ESA Director General or his Deputy
Issue 1	April 1998	<i>San Mill</i>	<i>[Signature]</i>
Revision 'A'	November 1998	<i>San Mill</i>	<i>[Signature]</i>
Revision 'B'	January 2001	<i>San Mill</i>	<i>[Signature]</i>

**SCC**ESA/SCC Detail Specification
No. 3401/065

Rev. 'B'

PAGE 2
ISSUE 1**DOCUMENTATION CHANGE NOTICE**

Rev. Letter	Rev. Date	Reference	CHANGE Item	Approved DCR No.
'A'	Nov. '98	P1. Cover page P2. DCN P7. Figure 1	: Maximum altitude amended to "33 000".	None None 221499
'B'	Jan. '01	P1. Cover page P2. DCN P30. Figure 2(c)	: Dimension 'b' corrected to "0.20 min." and "0.40 max."	None None 23932

**TABLE OF CONTENTS**

	<u>Page</u>
1. <u>GENERAL</u>	5
1.1 Scope	5
1.2 Range of Components	5
1.3 Maximum Ratings	5
1.4 Parameter Derating Information	5
1.5 Physical Dimensions	5
2. <u>APPLICABLE DOCUMENTS</u>	5
3. <u>TERMS, DEFINITIONS, ABBREVIATIONS, SYMBOLS AND UNITS</u>	5
4. <u>REQUIREMENTS</u>	31
4.1 General	31
4.2 Deviations from Generic Specification	31
4.2.1 Deviations from Special In-process Controls	31
4.2.2 Deviations from Final Production Tests	31
4.2.3 Deviations from Burn-in and Electrical Measurements	31
4.2.4 Deviations from Qualification Tests	31
4.2.5 Deviations from Lot Acceptance Tests	31
4.3 Mechanical Requirements	32
4.3.1 Dimension Check	32
4.3.2 Weight	32
4.3.3 Contact Capability	32
4.3.4 Contact Retention (In Insert)	32
4.3.5 Mating and Unmating Forces	32
4.3.6 Insert Retention (In Shell)	32
4.3.7 Jackscrew Retention	32
4.3.8 Contact Insertion and Withdrawal Forces	32
4.3.9 Engagement and Separation Forces	33
4.3.10 Oversize Pin Exclusion	33
4.3.11 Probe Damage	33
4.3.12 Solderability	33
4.4 Materials and Finishes	33
4.4.1 Shells	33
4.4.2 Inserts	33
4.4.3 Contacts	33
4.4.4 Contact Retaining Clip	34
4.4.5 Guiding and Locking Devices	34
4.4.6 Magnetism Level	34
4.5 Marking	34
4.5.1 General	34
4.5.2 Contact Position	34
4.5.3 The SCC Component Number	34
4.5.4 Characteristics	35
4.5.5 Traceability Information	35
4.6 Electrical Measurements	35
4.6.1 Electrical Measurements at Room Temperature	35
4.6.2 Electrical Measurements at High and Low Temperatures	35
4.6.3 Circuits for Electrical Measurements	35
4.7 Burn-in and Electrical Measurements	35



	<u>Page</u>
4.8 Environmental and Endurance Tests	36
4.8.1 Measurements and Inspections on Completion of Environmental Tests	36
4.8.2 Measurements and Inspections at Intermediate Points during Endurance Tests	36
4.8.3 Measurements and Inspections on Completion of Endurance Tests	36
4.8.4 Conditions for Operating Life Tests	36
4.8.5 Electrical Circuit for Operating Life Tests	36
4.8.6 Conditions for High Temperature Storage Test	36

TABLES

1(a) Range of Components	6
1(b) Maximum Ratings	7
2 Electrical Measurements at Room Temperature	37
3 Not Applicable	N/A
4 Not Applicable	N/A
5 Not Applicable	N/A
6 Measurements and Inspections on Completion of Environmental and Endurance Testing	38

FIGURES

1 Parameter Derating Information	7
2(a) Inserts: Plugs and Receptacles	8
2(b) Guiding and Locking Devices	24
2(c) Contact Mounting Configurations	27

APPENDICES (Applicable to specific Manufacturers only)

None.

**1. GENERAL****1.1 SCOPE**

This specification details the ratings, physical and electrical characteristics, test and inspection data for Connectors and Savers, Electrical, Rectangular, Non-removable PCB Contacts, based on Type MHD. It shall be read in conjunction with:

- ESA/SCC Generic Specification No. 3401, Connectors, Electrical, Non-Filtered, Circular and Rectangular,

the requirements of which are supplemented herein.

1.2 RANGE OF COMPONENTS

The different configurations of the connectors specified herein and guiding and locking devices, which are also covered by this specification are given in Table 1(a).

1.3 MAXIMUM RATINGS

The maximum ratings applicable to the connectors specified herein, which shall not be exceeded at any time during use or storage, are scheduled in Table 1(b).

1.4 PARAMETER DERATING INFORMATION

The applicable derating information for the connectors specified herein is shown in Figure 1.

1.5 PHYSICAL DIMENSIONS

The physical dimensions of the connectors, plugs and receptacles, guiding and locking devices specified herein, and the contact mounting configurations, are shown in Figures 2(a), 2(b) and 2(c).

2. APPLICABLE DOCUMENTS

The following documents form part of this specification and shall be read in conjunction with it:-

- (a) ESA/SCC Generic Specification No. 3401, Connectors, Electrical, Non-Filtered, Circular and Rectangular

3. TERMS, DEFINITIONS, ABBREVIATIONS, SYMBOLS AND UNITS

For the purpose of this specification, the terms, definitions, abbreviations, symbols and units specified in ESA/SCC Basic Specification No. 21300 shall apply.



TABLE 1(a) - RANGE OF COMPONENTS

NUMBER OF CONTACTS

NO. OF CONTACTS (Note 1)	MAX. WEIGHT (2) (g)		MAX. ENGAGEMENT FORCE (N.max)	SEPARATION FORCE (N)	
	PLUG	RECEPTACLE		N.min	N.max
52	10.7	7.2	36.4	2.6	36.4
100	16.4	13.1	70	5.0	70
152	25.7	20.1	106.4	7.6	106.4
200	32.5	25.9	140	10	140
252	44.1	33	176.4	12.6	176.4
300	48.5	38.8	210	15	210
352	57.2	43.2	246.4	17.6	246.4
400	64.5	49.2	280	20	280

NOTES

1. See Figure 2(a).
2. Weights with contacts and without accessories.

CONTACT TYPES

CONTACT CODES	CONTACT TYPES
10	Through board solder - 90° for PCB thickness: 1.44 - 1.76 mm
11	Through board solder - 90° for PCB thickness: 1.98 - 2.42 mm
12	Through board solder - 90° for PCB thickness: 2.88 - 3.52 mm
30	Through board solder - straight for PCB thickness: 2.16 - 2.64 mm
31	Through board solder - straight for PCB thickness: 2.88 - 3.52 mm
43	Surface mount for PCB thickness: 2.16 - 2.64 mm (Centred PCB)
45	Surface mount for PCB thickness: 1.44 - 2.40 mm (Off-centre PCB)
47	Surface mount for PCB thickness: 2.16 - 2.64 mm (Off-centre PCB)
91	Contact for connector saver male - female

NOTES

1. See Figure 2(c).

GUIDING AND LOCKING DEVICES

GUIDING AND LOCKING DEVICES CODE	MOUNTING ON	MAX. WEIGHT (g)
110	Plug	0.55
111	Plug	1.35
121	Receptacle	0.65
124	Receptacle	1.50
134	Receptacle	1.30
201	Saver Receptacle	-

NOTES

1. See Figure 2(b).

**TABLE 1(b) - MAXIMUM RATINGS**

No.	CHARACTERISTIC	SYMBOL	MAXIMUM RATING	UNIT	REMARKS
1	Working Voltage Sea Level	V	200	Vrms	Note 1
2	Rated Current	I_R	2.0	A	
3	Operating Temperature Range	T_{op}	- 55 to + 125	°C	T_{amb}
4	Storage Temperature Range	T_{stg}	- 55 to + 125	°C	
5	Soldering Temperature	T_{sol}	+ 260	°C	Note 2

NOTES

1. Between contacts and shell.
2. Duration 10 seconds maximum and the same contact shall not be resoldered until 3 minutes have elapsed.

FIGURE 1 - PARAMETER DERATING INFORMATIONWorking Voltage versus Altitude



FIGURE 2 - PHYSICAL DIMENSIONS

FIGURE 2(a) - INSERTS: PLUGS AND RECEPTACLES

RECEPTACLE, 52 CONTACTS

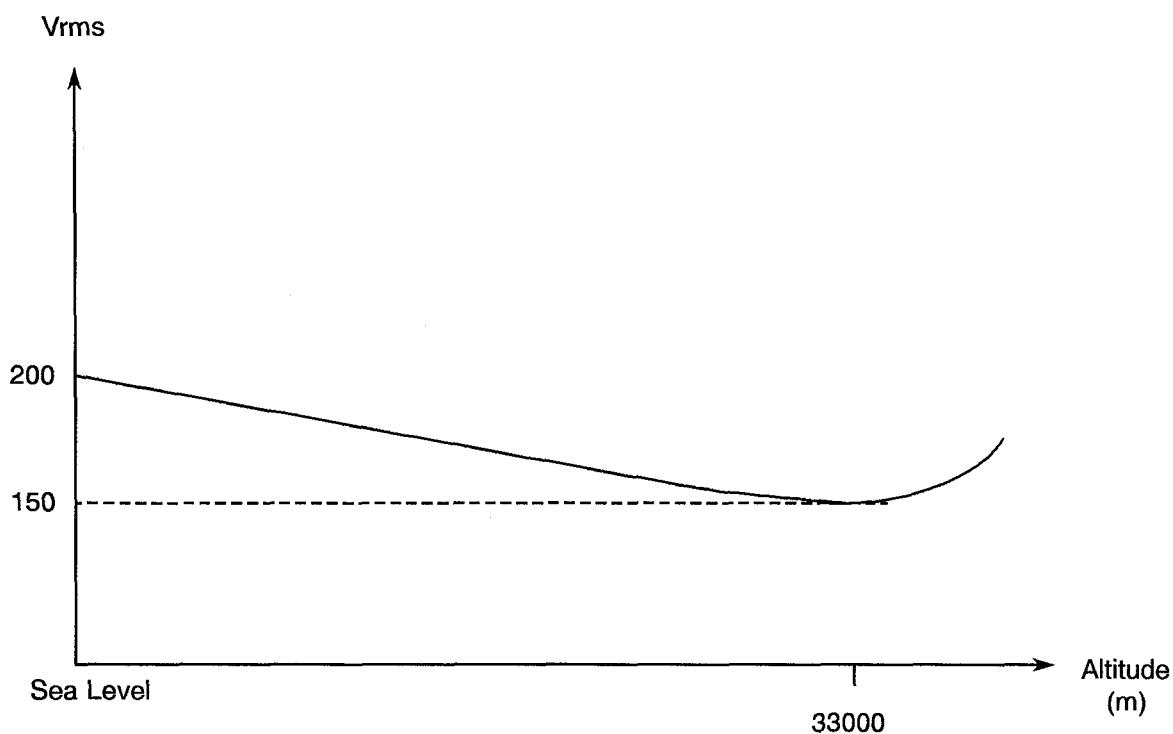
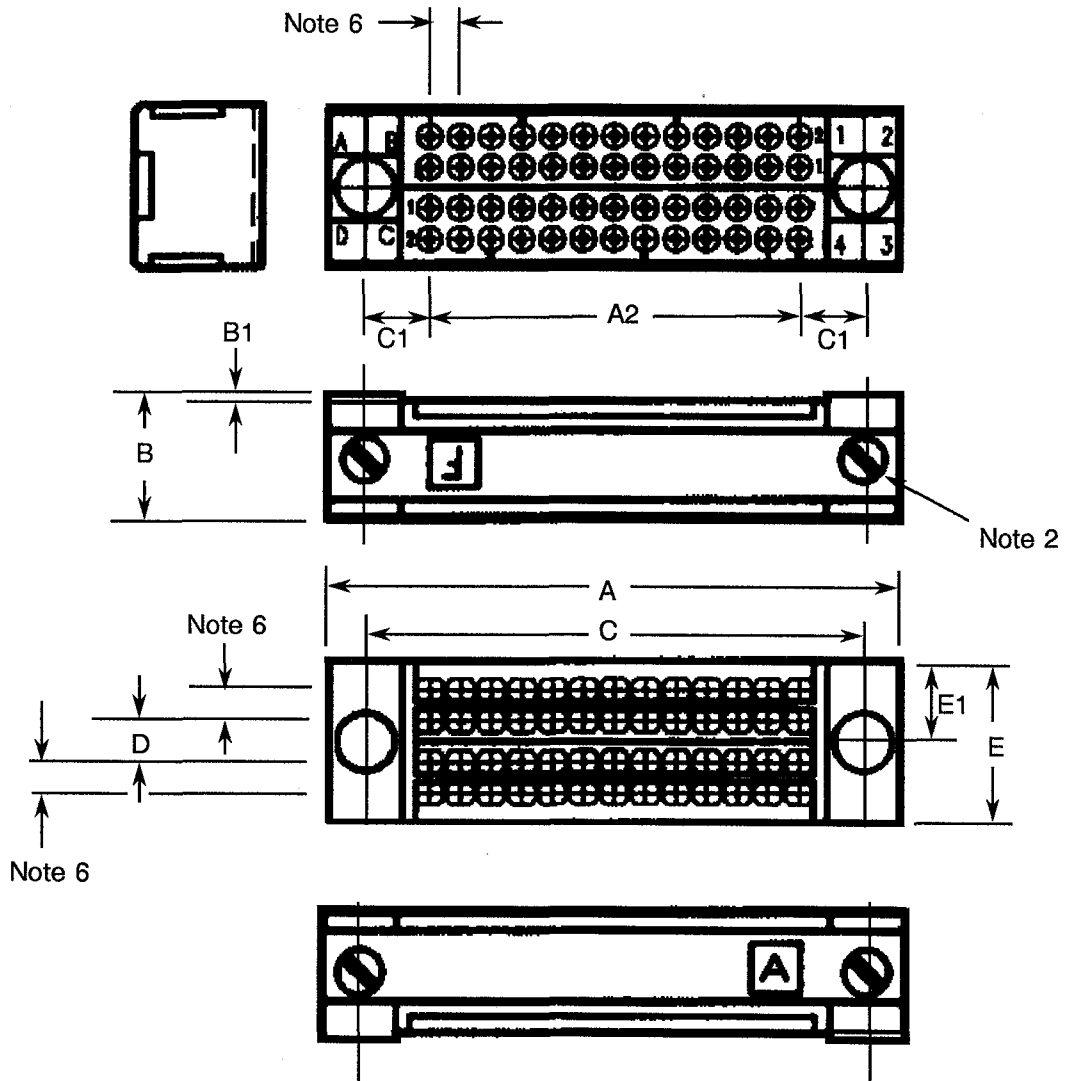

Symbol/ Dim. (1)	<u>A</u>	<u>A2</u>	B	B1	<u>C</u>	<u>C1</u>	<u>D</u>	E	<u>E1</u>
MIN.	35.1	22.66	7.75	0.3	30.65	3.77	2.34	9.9	4.90
MAX.	35.4	23.06	8.05	0.6	30.95	4.17	2.74	10.1	5.10

NOTES

1. All dimensions are in millimetres.
2. Torque : 10N.cm.
3. Underlined dimensions, in table, are critical to ensure intermateability.
4. The front of the insert shall be marked with the minimum marking shown.
5. Orientation of labelling of contacts and guiding devices is not a true representation.
6. Pitch : 1.905mm.

FIGURE 2 - PHYSICAL DIMENSIONS (CONT.)

FIGURE 2(a) - INSERTS: PLUGS AND RECEPTACLES (CONT.)

RECEPTACLE, 100 CONTACTS

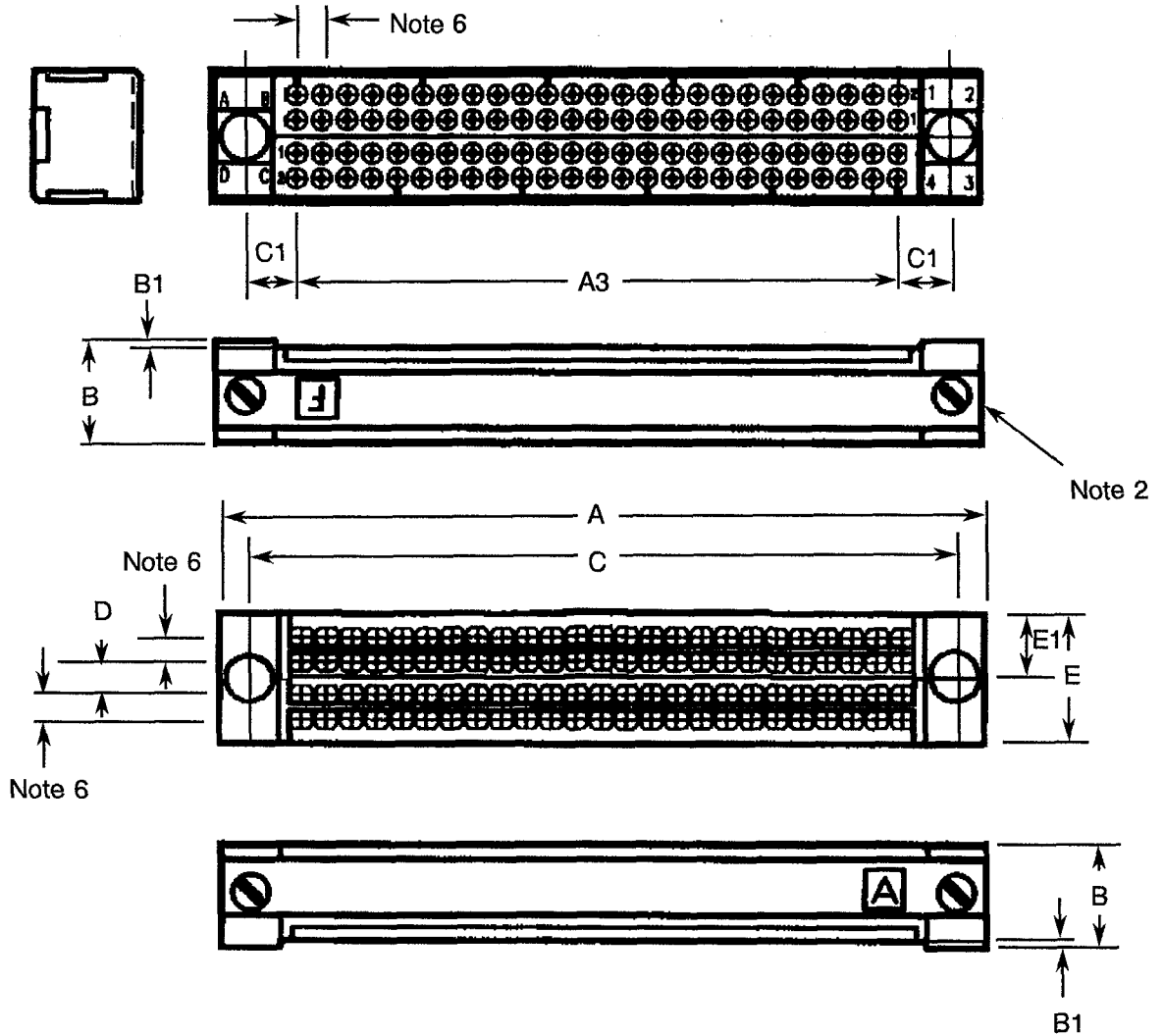

Symbol/ Dim. (1)	A	<u>A3</u>	B	B1	<u>C</u>	<u>C1</u>	D	E	<u>E1</u>
MIN.	57.9	45.52	7.75	0.3	53.51	3.77	2.34	9.9	4.90
MAX.	58.2	45.92	8.05	0.6	53.81	4.17	2.74	10.1	5.10

NOTES

1. All dimensions are in millimetres.
2. Torque : 10N.cm.
3. Underlined dimensions, in table, are critical to ensure intermateability.
4. The front of the insert shall be marked with the minimum marking shown.
5. Orientation of labelling of contacts and guiding devices is not a true representation.
6. Pitch : 1.905mm.



FIGURE 2 - PHYSICAL DIMENSIONS (CONT.)

FIGURE 2(a) - INSERTS: PLUGS AND RECEPTACLES (CONT.)

RECEPTACLE, 152 CONTACTS

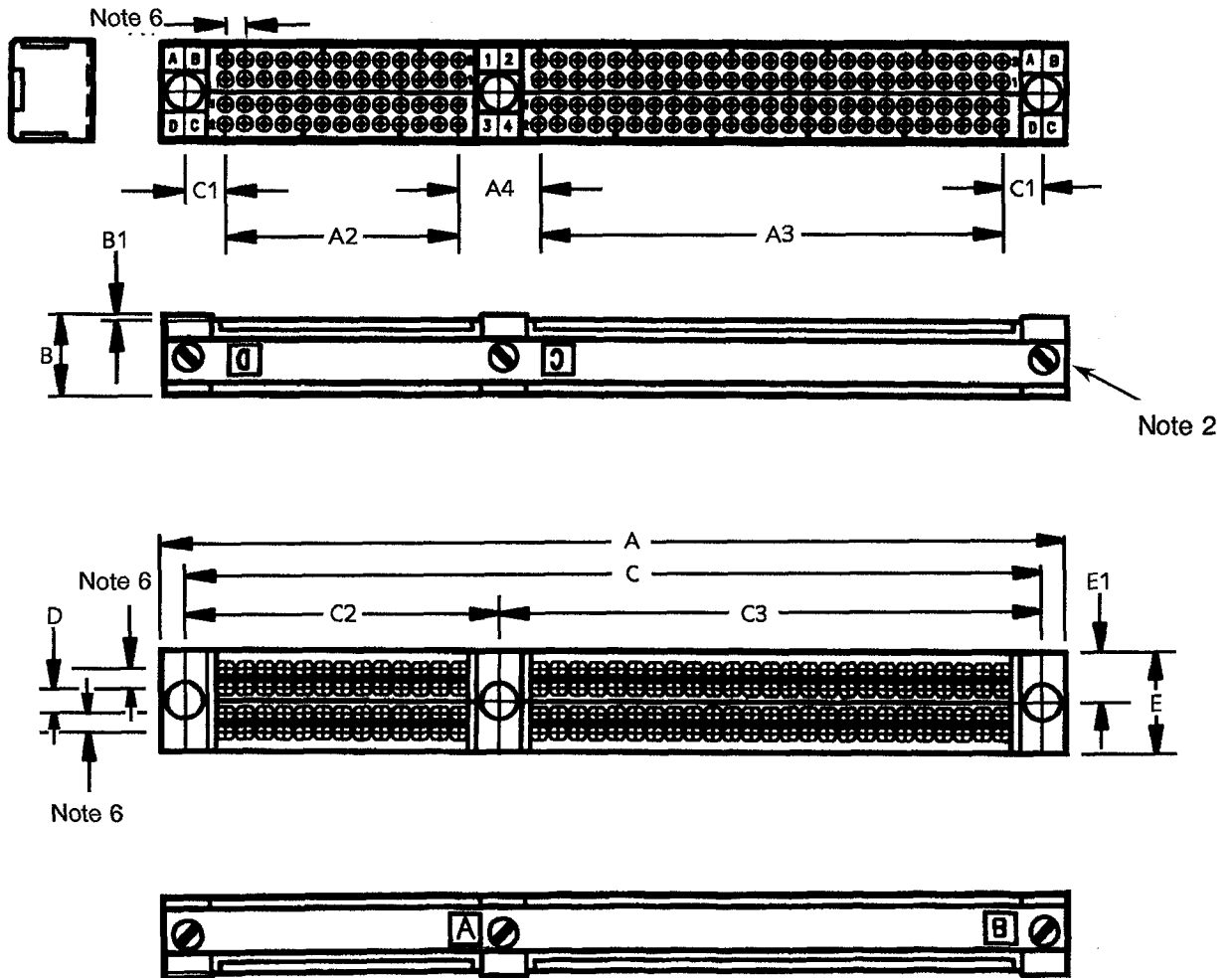

Symbol/ Dim. (1)	A	<u>A2</u>	<u>A3</u>	<u>A4</u>	B	B1	<u>C</u>	<u>C1</u>	<u>C2</u>	<u>C3</u>	<u>D</u>	E	<u>E1</u>
MIN.	88.8	22.66	45.52	7.74	7.75	0.3	84.3	3.77	30.65	53.51	2.34	9.9	4.90
MAX.	89.1	23.06	45.92	8.14	8.05	0.6	84.6	4.17	30.95	53.81	2.74	10.1	5.10

NOTES

1. All dimensions are in millimetres.
2. Torque : 10N.cm.
3. Underlined dimensions, in table, are critical to ensure intermateability.
4. The front of the insert shall be marked with the minimum marking shown.
5. Orientation of labelling of contacts and guiding devices is not a true representation.
6. Pitch : 1.905mm.



FIGURE 2 - PHYSICAL DIMENSIONS (CONT.)

FIGURE 2(a) - INSERTS: PLUGS AND RECEPTACLES (CONT.)

RECEPTACLE, 200 CONTACTS

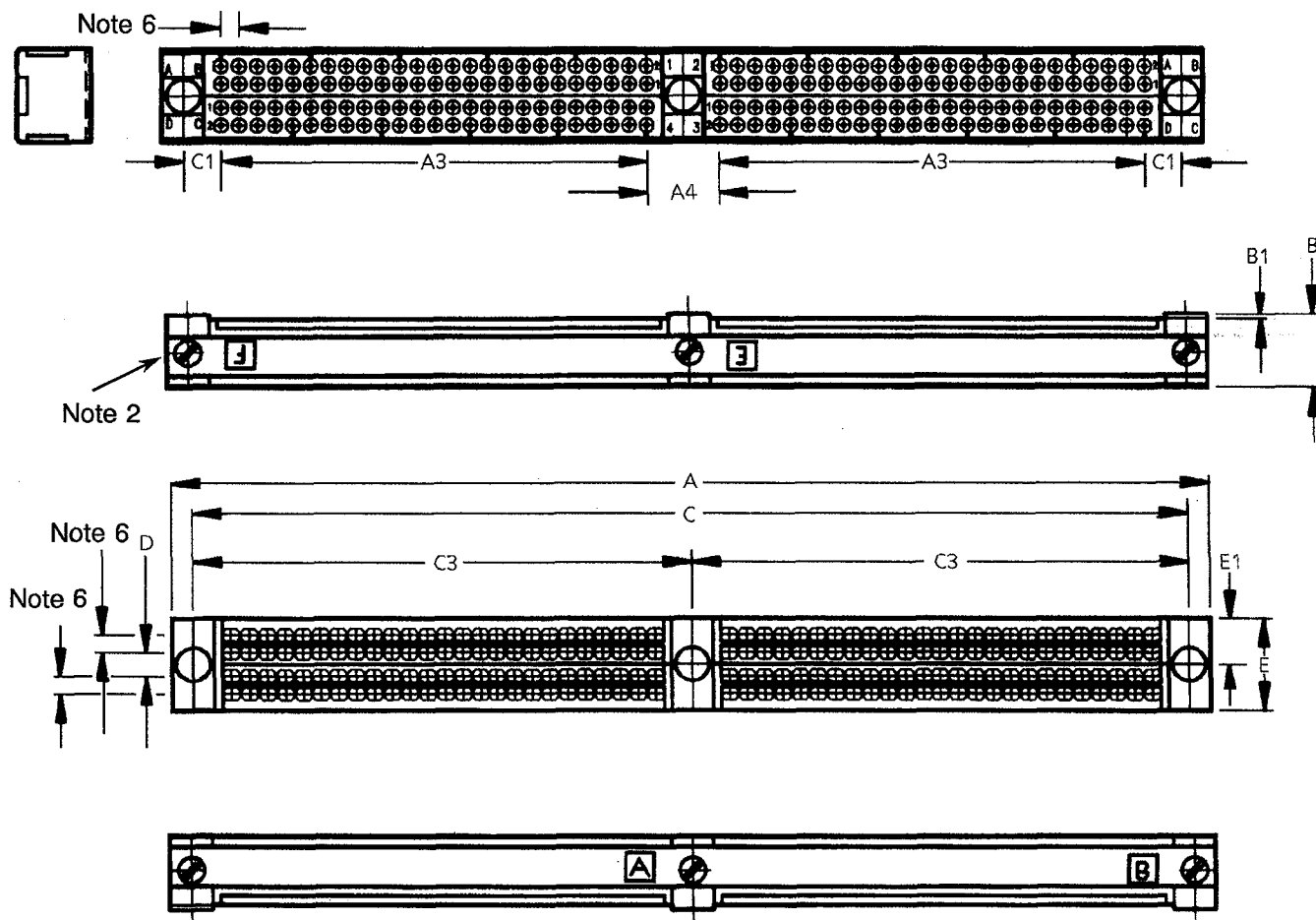

Symbol/ Dim. (1)	A	<u>A3</u>	<u>A4</u>	B	B1	<u>C</u>	<u>C1</u>	<u>C3</u>	<u>D</u>	E	<u>E1</u>
MIN.	111.6	45.52	7.74	7.75	0.3	107.16	3.77	53.51	2.34	9.9	4.90
MAX.	111.9	45.92	8.14	8.05	0.6	107.46	4.17	53.81	2.74	10.1	5.10

NOTES

1. All dimensions are in millimetres.
2. Torque : 10N.cm.
3. Underlined dimensions, in table, are critical to ensure intermateability.
4. The front of the insert shall be marked with the minimum marking shown.
5. Orientation of labelling of contacts and guiding devices is not a true representation.
6. Pitch : 1.905mm.



FIGURE 2 - PHYSICAL DIMENSIONS (CONT.)

FIGURE 2(a) - INSERTS: PLUGS AND RECEPTACLES (CONT.)

RECEPTACLE, 252 CONTACTS

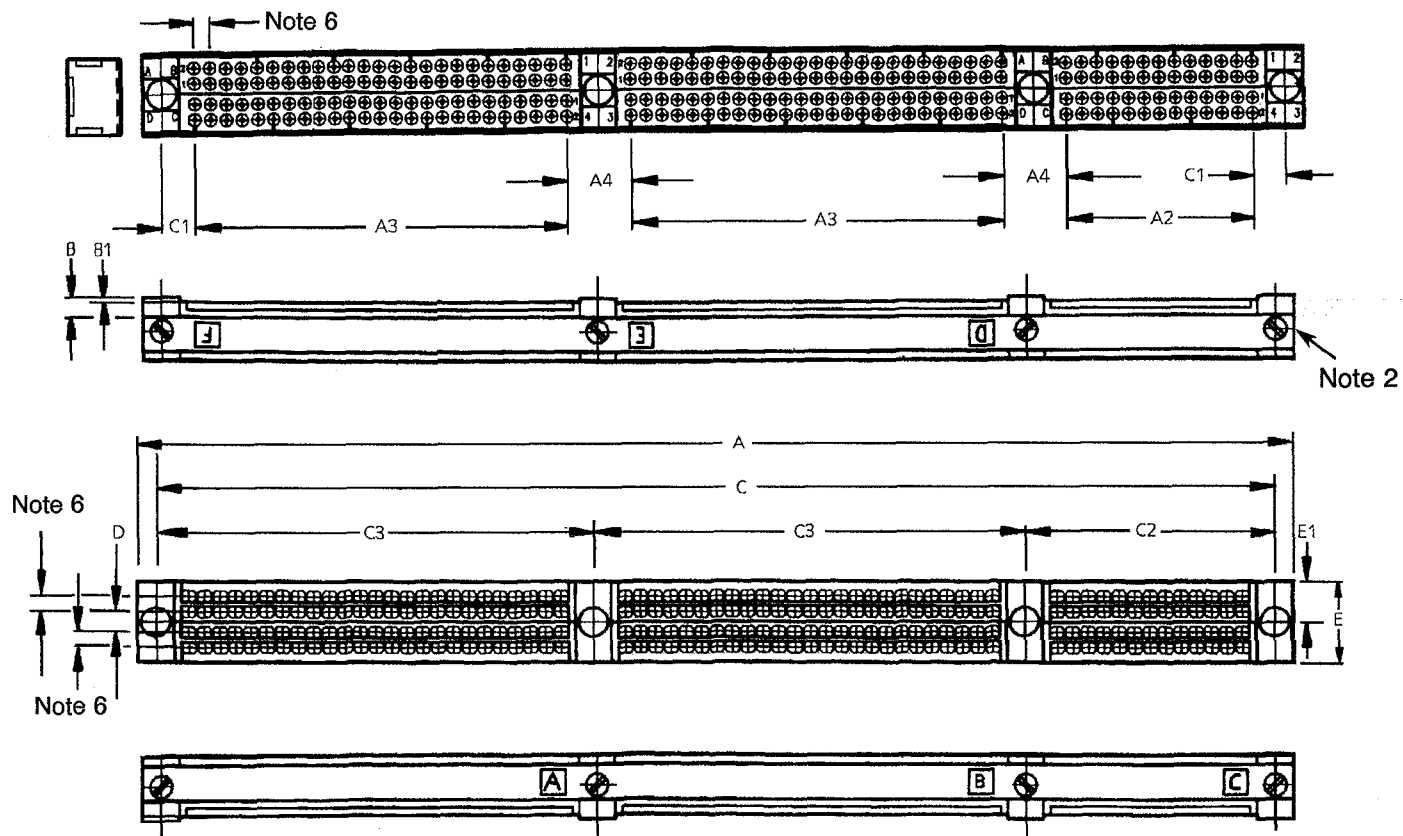

Symbol/ Dim. (1)	A	<u>A2</u>	<u>A3</u>	<u>A4</u>	B	B1	<u>C</u>	<u>C1</u>	<u>C2</u>	<u>C3</u>	D	E	<u>E1</u>
MIN.	142.5	22.66	45.52	7.74	7.75	0.3	137.96	3.77	30.65	53.51	2.34	9.9	4.90
MAX.	142.8	23.06	45.92	8.14	8.05	0.6	138.26	4.17	30.95	53.81	2.74	10.1	5.10

NOTES

1. All dimensions are in millimetres.
2. Torque : 10N.cm.
3. Underlined dimensions, in table, are critical to ensure intermateability.
4. The front of the insert shall be marked with the minimum marking shown.
5. Orientation of labelling of contacts and guiding devices is not a true representation.
6. Pitch : 1.905mm.



FIGURE 2 - PHYSICAL DIMENSIONS (CONT.)

FIGURE 2(a) - INSERTS: PLUGS AND RECEPTACLES (CONT.)

RECEPTACLE, 300 CONTACTS

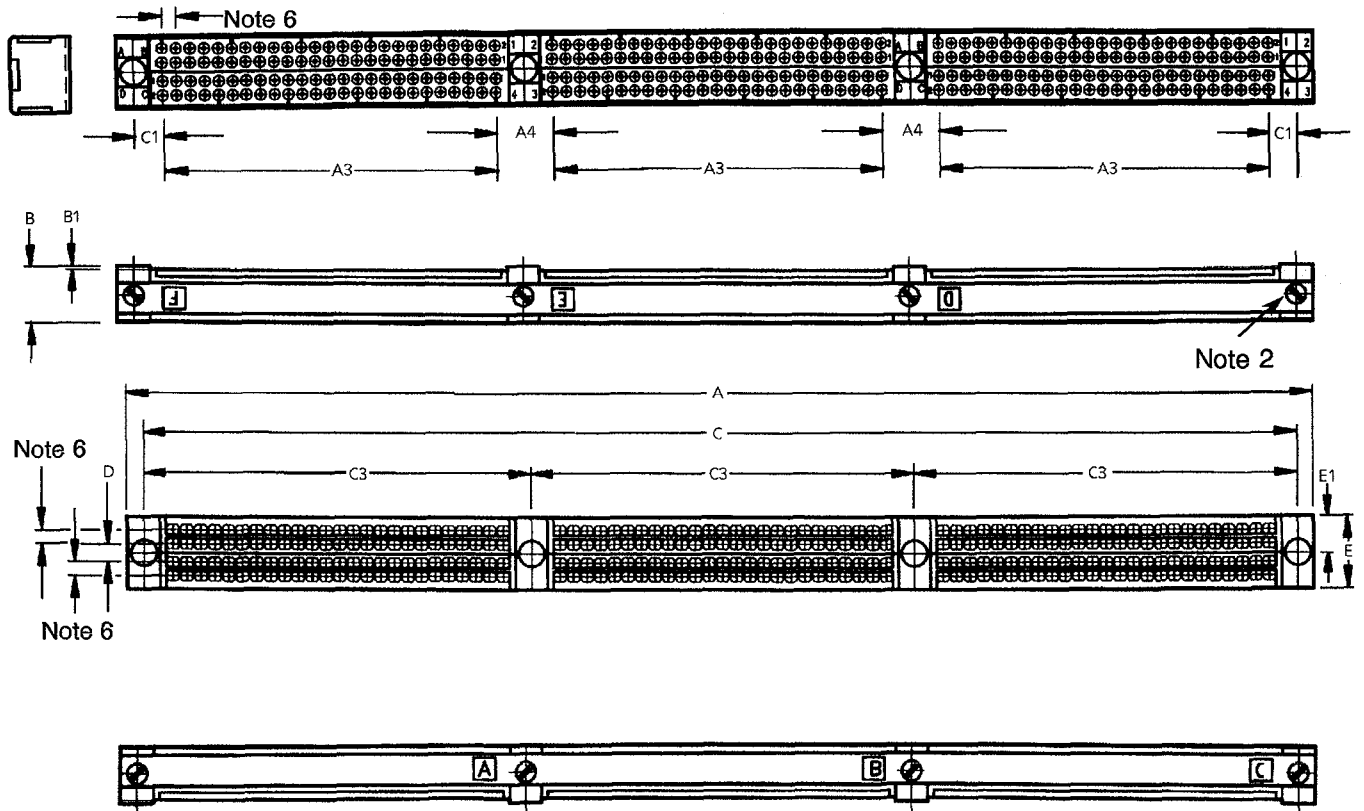

Symbol/ Dim. (1)	A	<u>A3</u>	<u>A4</u>	B	B1	<u>C</u>	<u>C1</u>	<u>C3</u>	<u>D</u>	E	<u>E1</u>
MIN.	165.3	45.52	7.74	7.75	0.3	160.82	3.77	53.51	2.34	9.9	4.90
MAX.	165.6	45.92	8.14	8.05	0.6	161.12	4.17	53.81	2.74	10.1	5.10

NOTES

1. All dimensions are in millimetres.
2. Torque : 10N.cm.
3. Underlined dimensions, in table, are critical to ensure intermateability.
4. The front of the insert shall be marked with the minimum marking shown.
5. Orientation of labelling of contacts and guiding devices is not a true representation.
6. Pitch : 1.905mm.



FIGURE 2 - PHYSICAL DIMENSIONS (CONT.)

FIGURE 2(a) - INSERTS: PLUGS AND RECEPTACLES (CONT.)

RECEPTACLE, 352 CONTACTS

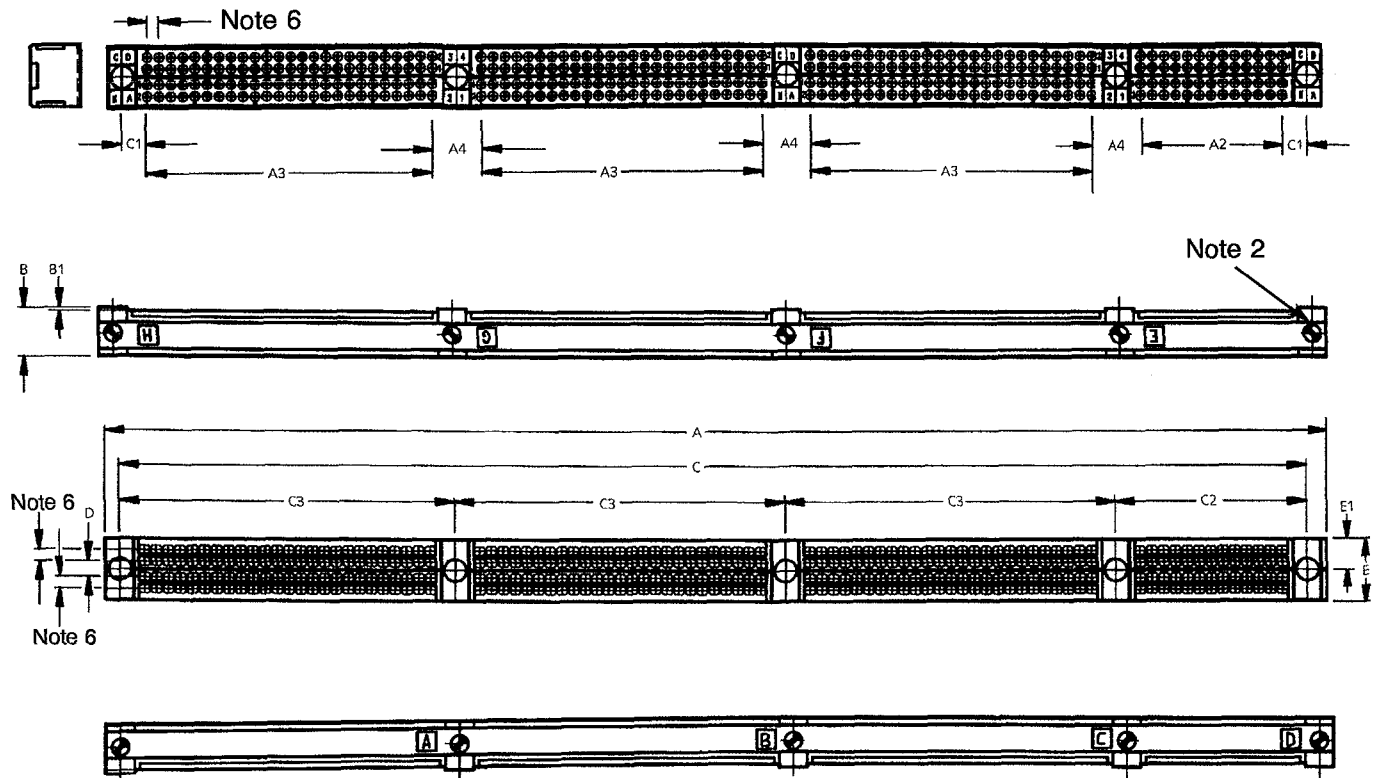

Symbol/ Dim. (1)	<u>A</u>	<u>A2</u>	<u>A3</u>	<u>A4</u>	B	B1	<u>C</u>	<u>C1</u>	<u>C2</u>	<u>C3</u>	<u>D</u>	E	<u>E1</u>
MIN.	196.2	22.66	45.52	7.74	7.75	0.3	191.62	3.77	30.65	53.51	2.34	9.9	4.90
MAX.	196.8	23.06	45.92	8.14	8.05	0.6	191.92	4.17	30.95	53.81	2.74	10.1	5.10

NOTES

1. All dimensions are in millimetres.
2. Torque : 10N.cm.
3. Underlined dimensions, in table, are critical to ensure intermateability.
4. The front of the insert shall be marked with the minimum marking shown.
5. Orientation of labelling of contacts and guiding devices is not a true representation.
6. Pitch : 1.905mm.



FIGURE 2 - PHYSICAL DIMENSIONS (CONT.)

FIGURE 2(a) - INSERTS: PLUGS AND RECEPTACLES (CONT.)

RECEPTACLE, 400 CONTACTS

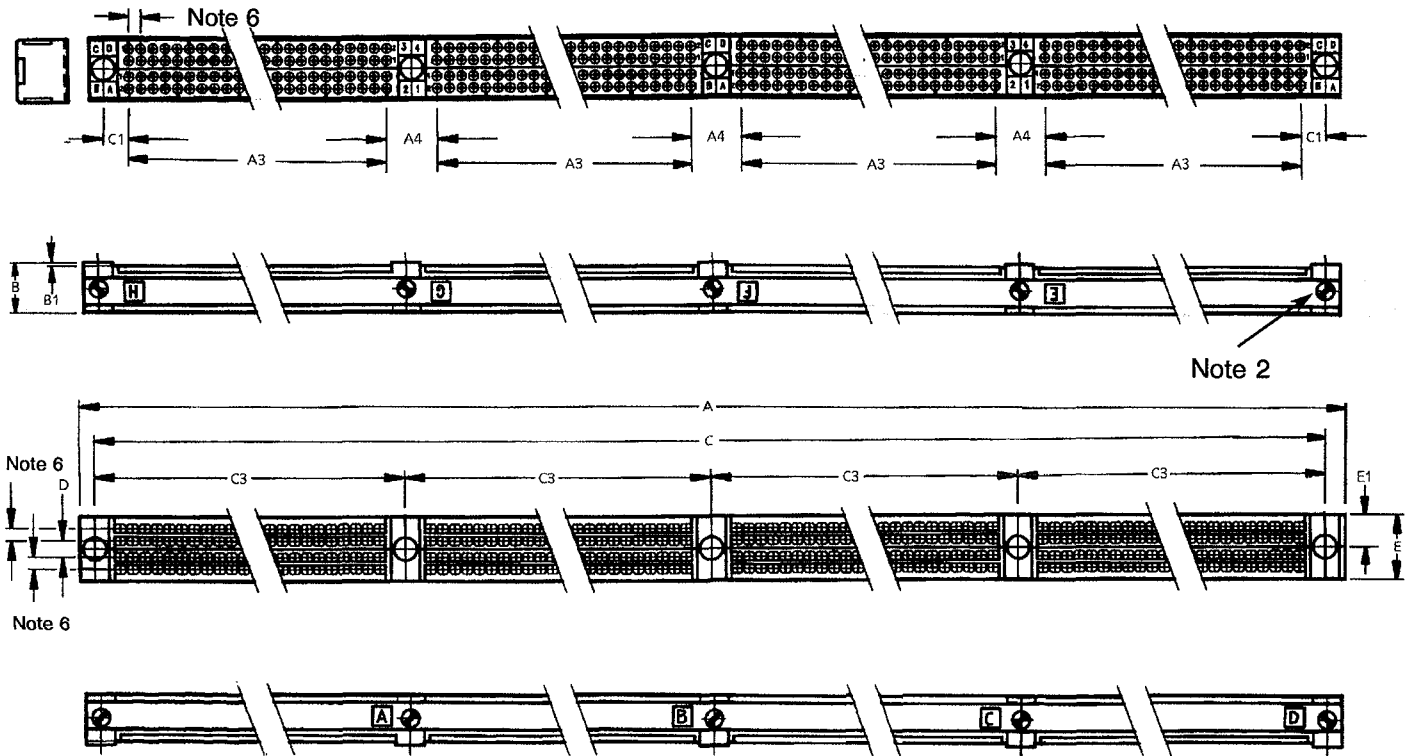

Symbol/ Dim. (1)	<u>A</u>	<u>A3</u>	<u>A4</u>	B	B1	<u>C</u>	<u>C1</u>	<u>C3</u>	<u>D</u>	E	<u>E1</u>
MIN.	219	45.52	7.74	7.75	0.3	214.48	3.77	53.51	2.34	9.9	4.90
MAX.	219.3	45.92	8.14	8.05	0.6	214.78	4.17	53.81	2.74	10.1	5.10

NOTES

1. All dimensions are in millimetres.
2. Torque : 10N.cm.
3. Underlined dimensions, in table, are critical to ensure intermateability.
4. The front of the insert shall be marked with the minimum marking shown.
5. Orientation of labelling of contacts and guiding devices is not a true representation.
6. Pitch : 1.905mm.



FIGURE 2 - PHYSICAL DIMENSIONS (CONT.)

FIGURE 2(a) - INSERTS: PLUGS AND RECEPTACLES (CONT.)

PLUG, 52 CONTACTS

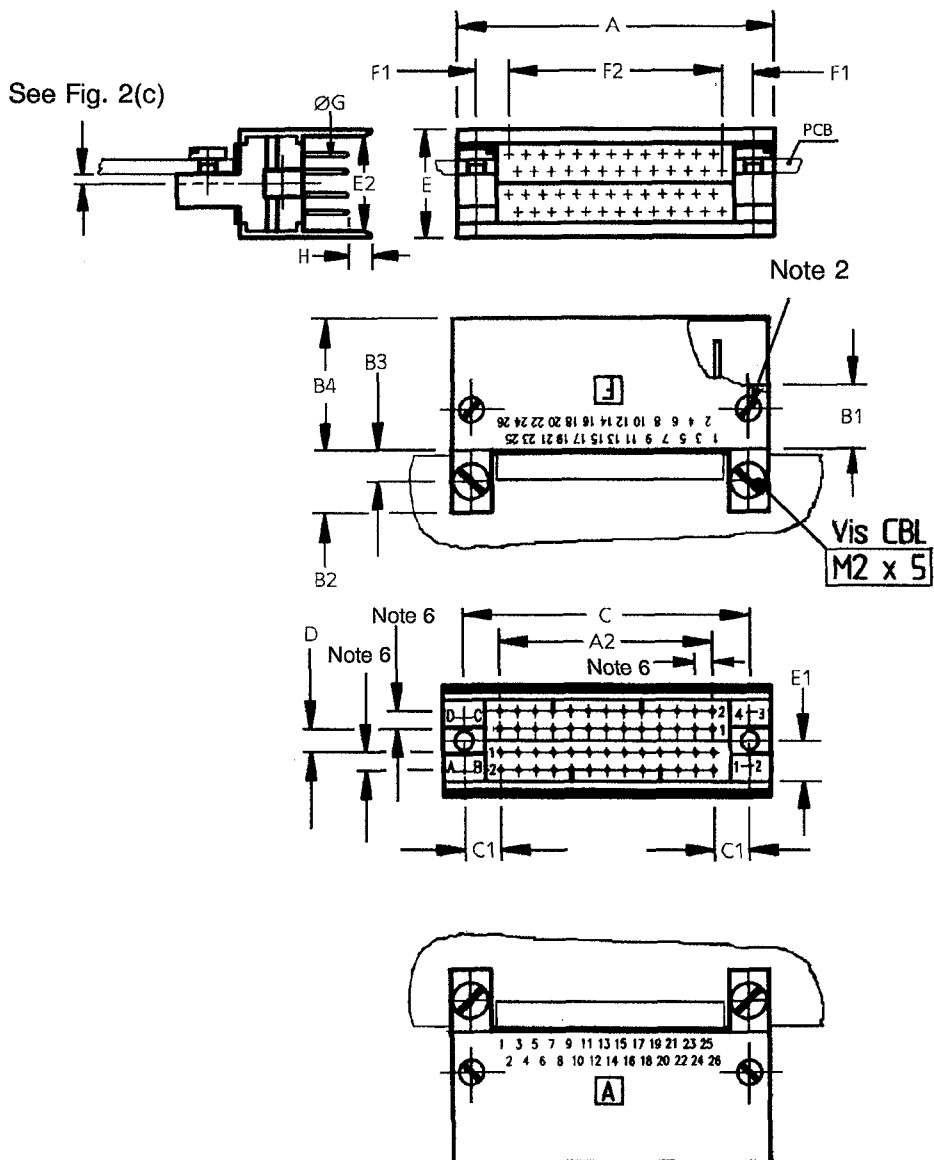

Symbol/ Dim. (1)	A	<u>A2</u>	B1	B2	B3	B4	<u>C</u>	<u>C1</u>	<u>D</u>	E	E1	E2	<u>F1</u>	<u>F2</u>	ØG	H
MIN.	35.1	22.66	7.0	-	3.5	14.3	30.65	3.77	2.34	-	5.05	10.20	3.29	23.61	0.42	2.0
MAX.	35.4	23.06	7.2	7.4	3.6	14.6	30.95	4.17	2.74	12	5.25	10.45	3.69	24.01	0.44	3.0

NOTES

- All dimensions are in millimetres.
- Torque : 10N.cm.
- Underlined dimensions, in table, are critical to ensure intermateability.
- The front of the insert shall be marked with the minimum marking shown.
- Orientation of labelling of contacts and guiding devices is not a true representation.
- Pitch : 1.905mm.



FIGURE 2 - PHYSICAL DIMENSIONS (CONT.)

FIGURE 2(a) - INSERTS: PLUGS AND RECEPTACLES (CONT.)

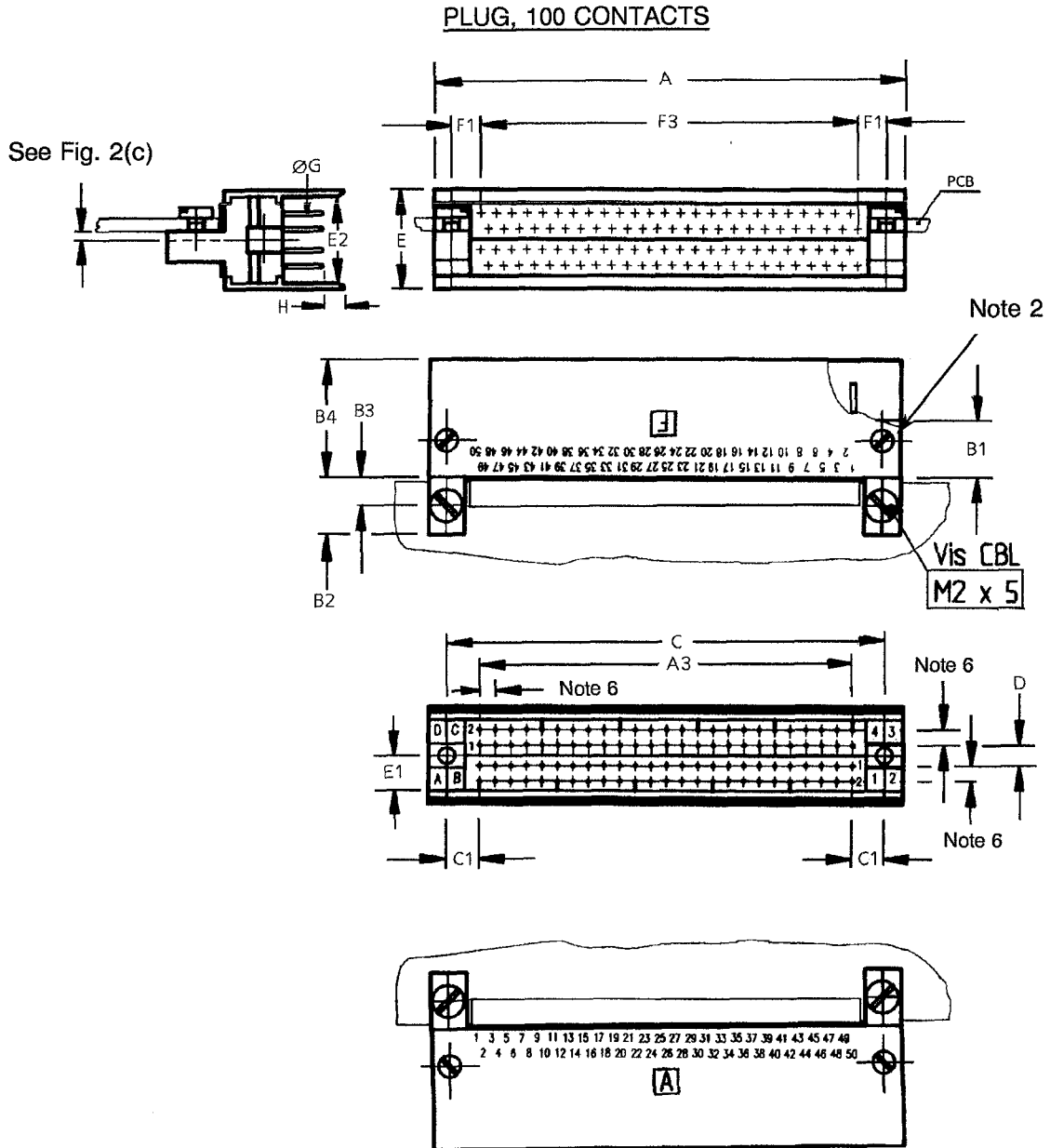

Symbol/ Dim. (1)	A	<u>A3</u>	B1	B2	B3	B4	<u>C</u>	<u>C1</u>	D	E	E1	E2	F1	F3	ØG	H
MIN.	57.9	45.52	7.0	-	3.5	14.3	53.51	3.77	2.34	-	5.05	10.20	3.29	46.47	0.42	2.0
MAX.	58.2	45.92	7.2	7.4	3.6	14.6	53.81	4.17	2.74	12	5.25	10.45	3.69	46.87	0.44	3.0

NOTES

1. All dimensions are in millimetres.
2. Torque : 10N.cm.
3. Underlined dimensions, in table, are critical to ensure intermateability.
4. The front of the insert shall be marked with the minimum marking shown.
5. Orientation of labelling of contacts and guiding devices is not a true representation.
6. Pitch : 1.905mm.



FIGURE 2 - PHYSICAL DIMENSIONS (CONT.)

FIGURE 2(a) - INSERTS: PLUGS AND RECEPTACLES (CONT.)

PLUG, 152 CONTACTS

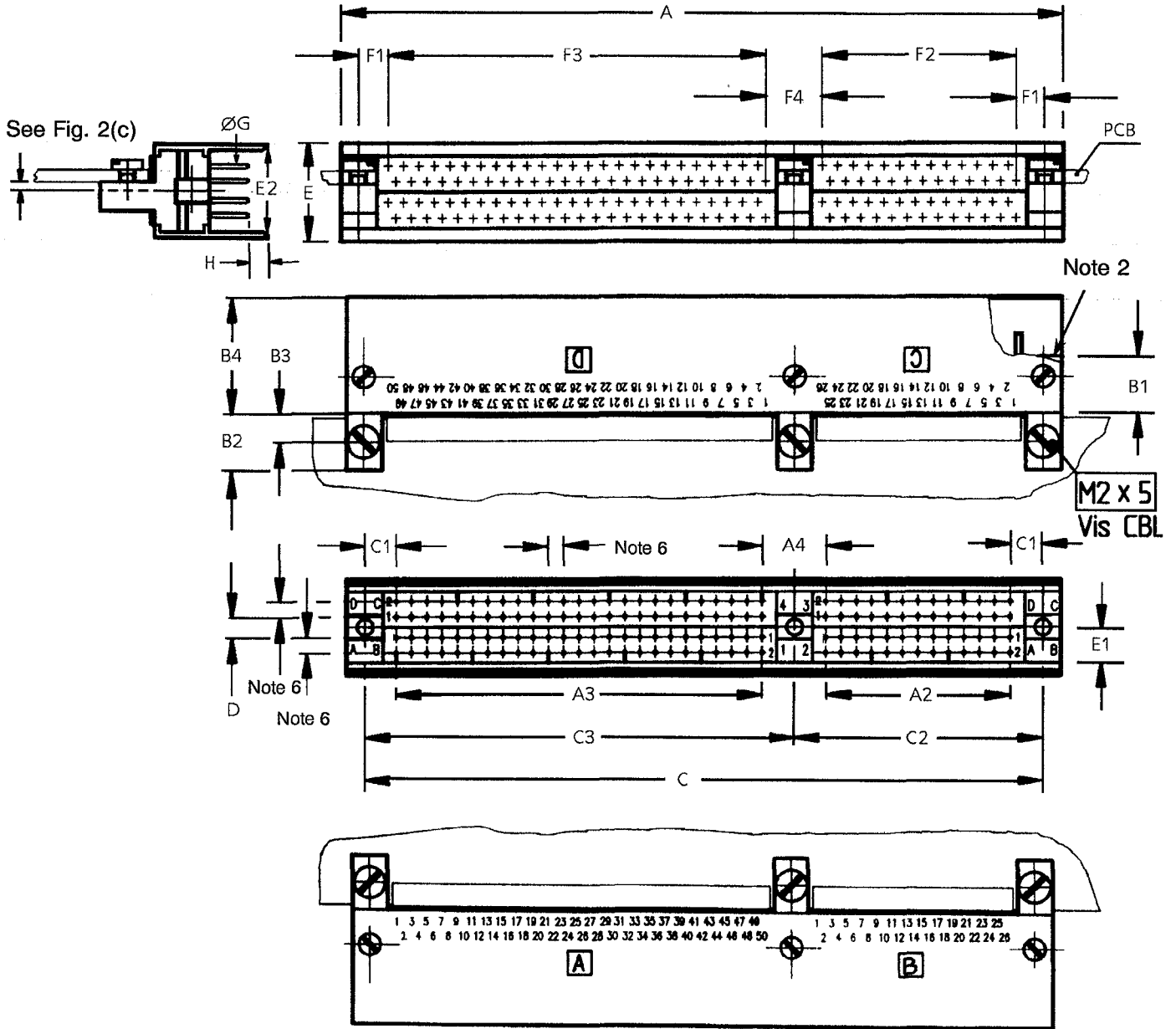

Symbol/ Dim. (1)	A	<u>A2</u>	<u>A3</u>	<u>A4</u>	B1	B2	B3	B4	<u>C</u>	<u>C1</u>	<u>C2</u>	<u>C3</u>	<u>D</u>	E	E1	E2	<u>F1</u>	<u>F2</u>	<u>F3</u>	<u>F4</u>	ØG	H
MIN.	88.8	22.66	45.52	7.74	7.0	-	3.5	14.3	84.305	3.77	30.65	53.51	2.34	-	5.05	10.20	3.29	23.61	46.47	6.79	0.42	2.0
MAX.	89.1	23.06	45.92	8.14	7.2	7.4	3.6	14.6	84.605	4.17	30.95	53.81	2.74	12	5.25	10.45	3.69	24.01	46.87	7.19	0.44	3.0

NOTES

1. All dimensions are in millimetres.
2. Torque : 10N.cm.
3. Underlined dimensions, in table, are critical to ensure intermateability.
4. The front of the insert shall be marked with the minimum marking shown.
5. Orientation of labelling of contacts and guiding devices is not a true representation.
6. Pitch : 1.905mm.



FIGURE 2 - PHYSICAL DIMENSIONS (CONT.)

FIGURE 2(a) - INSERTS: PLUGS AND RECEPTACLES (CONT.)

PLUG, 200 CONTACTS

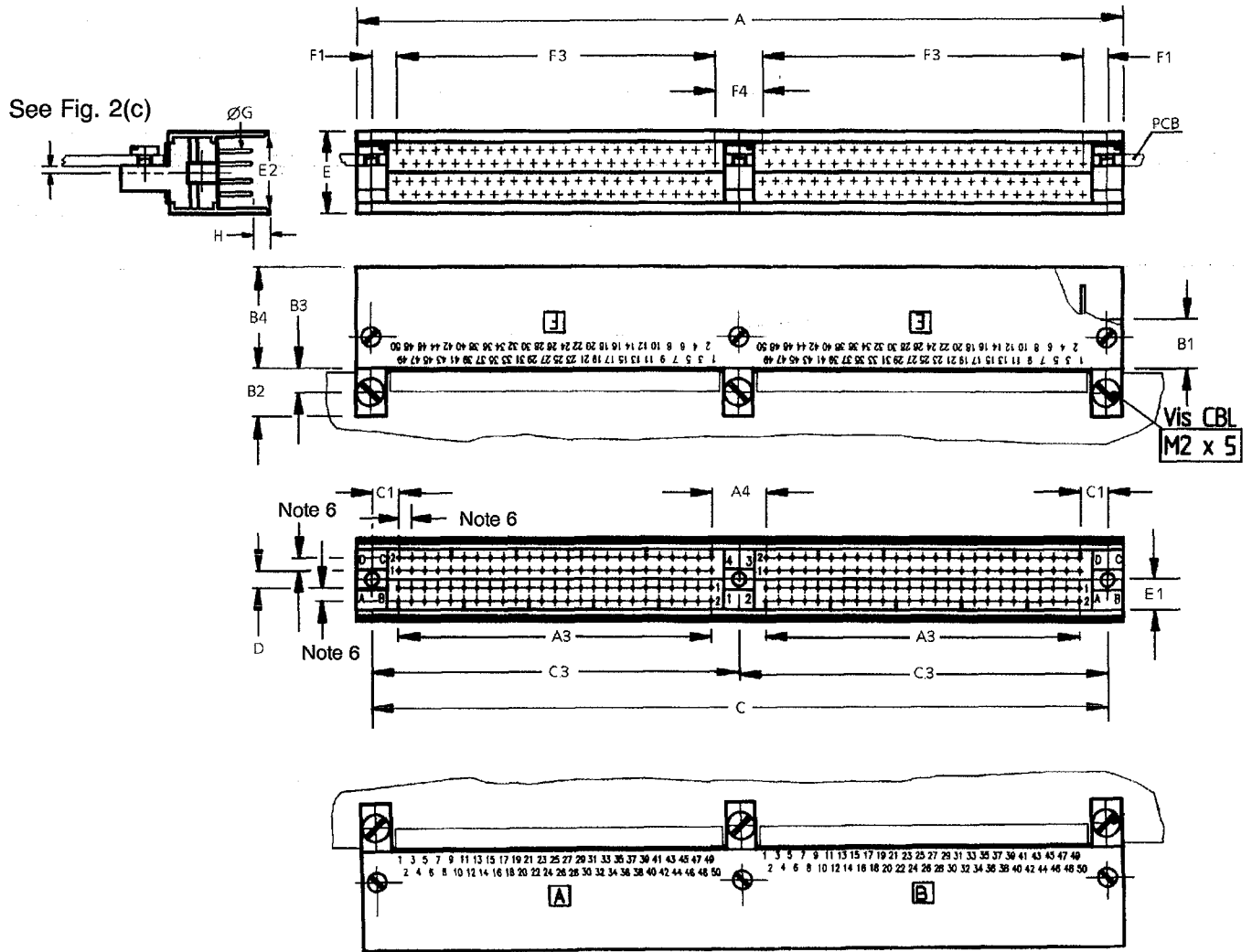

Symbol / Dim. (1)	A	<u>A3</u>	<u>A4</u>	B1	B2	B3	B4	<u>C</u>	<u>C1</u>	<u>C3</u>	D	E	E1	E2	F1	F3	F4	ØG	H
MIN.	111.6	45.52	7.74	7.0	-	3.5	14.3	107.17	3.77	53.51	2.34	-	5.05	10.20	3.29	46.47	6.79	0.42	2.0
MAX.	111.9	45.92	8.14	7.2	7.4	3.6	14.6	107.47	4.17	53.81	2.74	12	5.25	10.45	3.69	46.87	7.19	0.44	3.0

NOTES

1. All dimensions are in millimetres.
2. Torque : 10N.cm.
3. Underlined dimensions, in table, are critical to ensure intermateability.
4. The front of the insert shall be marked with the minimum marking shown.
5. Orientation of labelling of contacts and guiding devices is not a representation.
6. Pitch : 1.905mm.



FIGURE 2 - PHYSICAL DIMENSIONS (CONT.)

FIGURE 2(a) - INSERTS: PLUGS AND RECEPTACLES (CONT.)

PLUG, 252 CONTACTS

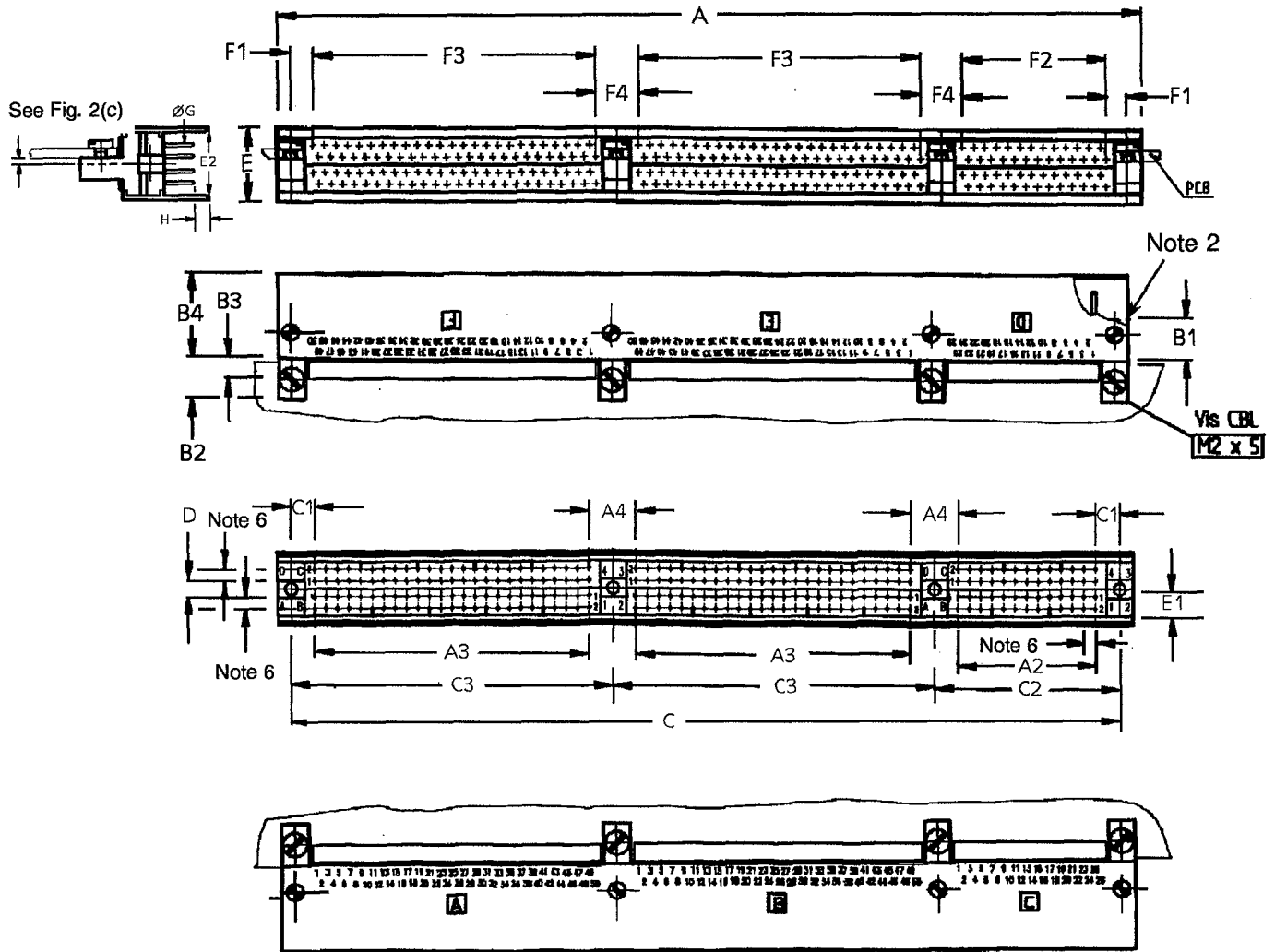

Symbol / Dim. (1)	A	<u>A2</u>	<u>A3</u>	<u>A4</u>	B1	B2	B3	B4	C	<u>C1</u>	<u>C2</u>	<u>C3</u>	D	E	E1	E2	<u>F1</u>	<u>F2</u>	<u>F3</u>	<u>F4</u>	ØG	H
MIN.	142.5	22.66	45.52	7.74	7.0	-	3.5	14.3	137.96	3.77	30.65	53.51	2.34	-	5.05	10.20	3.29	23.61	46.47	6.79	0.42	2.0
MAX.	142.8	23.06	45.92	8.14	7.2	7.4	3.6	14.6	138.26	4.17	30.95	53.81	2.74	12	5.25	10.45	3.69	24.01	46.87	7.19	0.44	3.0

NOTES

1. All dimensions are in millimetres.
2. Torque : 10N.cm.
3. Underlined dimensions, in table, are critical to ensure intermateability.
4. The front of the insert shall be marked with the minimum marking shown.
5. Orientation of labelling of contacts and guiding devices is not a true representation.
6. Pitch : 1.905mm.



FIGURE 2 - PHYSICAL DIMENSIONS (CONT.)

FIGURE 2(a) - INSERTS: PLUGS AND RECEPTACLES (CONT.)

PLUG, 300 CONTACTS

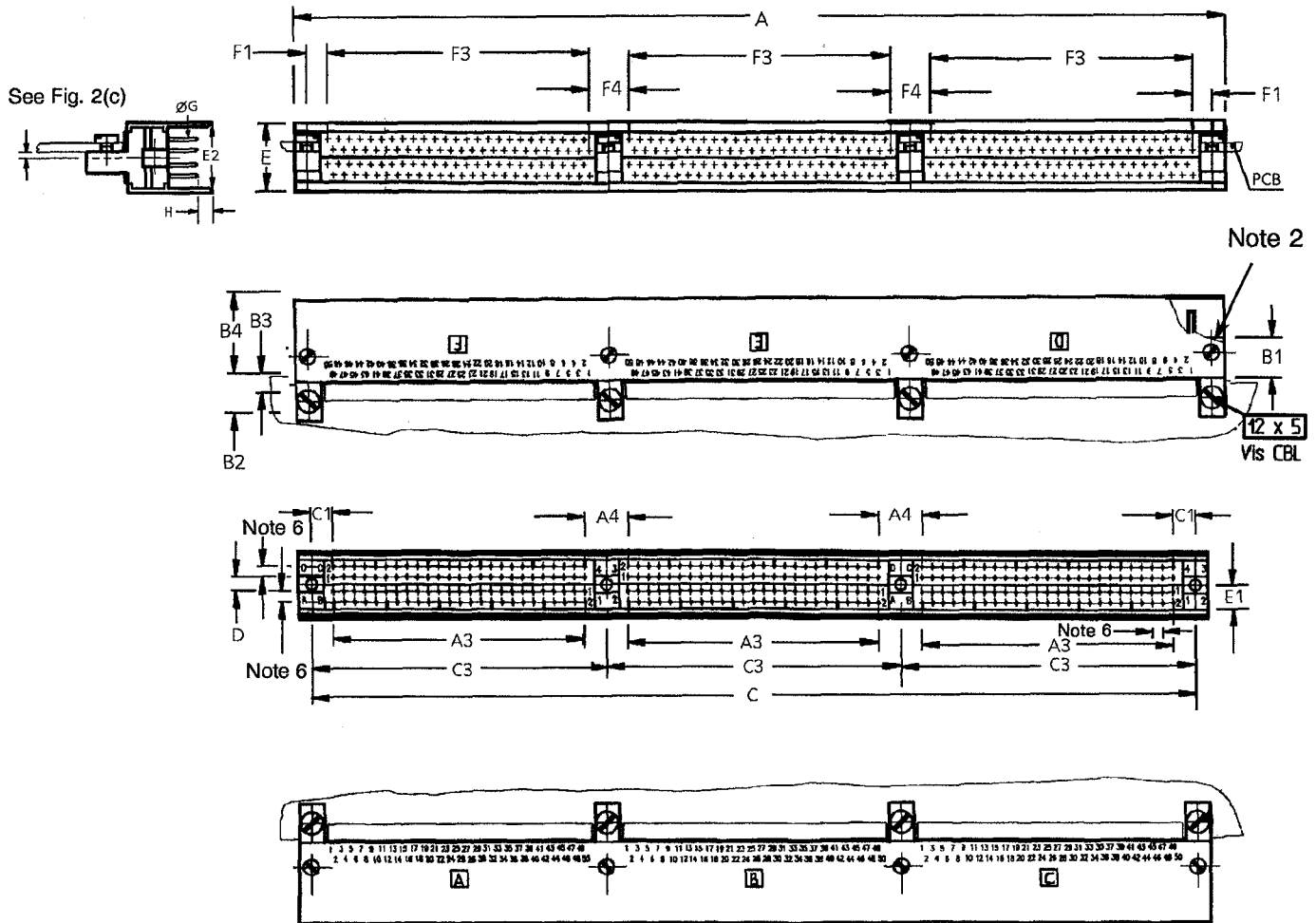

Symbol / Dim. (1)	A	<u>A3</u>	<u>A4</u>	B1	B2	B3	B4	<u>C</u>	<u>C1</u>	<u>C3</u>	<u>D</u>	E	E1	E2	<u>F1</u>	<u>F3</u>	<u>F4</u>	ØG	H
MIN.	165.3	45.52	7.74	7.0	-	3.5	14.3	160.82	3.77	53.51	2.34	-	5.05	10.20	3.29	46.47	6.79	0.42	2.0
MAX.	165.6	45.92	8.14	7.2	7.4	3.6	14.6	161.12	4.17	53.81	2.74	12	5.25	10.45	3.69	46.87	7.19	0.44	3.0

NOTES

1. All dimensions are in millimetres.
2. Torque : 10N.cm.
3. Underlined dimensions, in table, are critical to ensure intermateability.
4. The front of the insert shall be marked with the minimum marking shown.
5. Orientation of labelling of contacts and guiding devices is not a true representation.
6. Pitch : 1.905mm.



FIGURE 2 - PHYSICAL DIMENSIONS (CONT.)

FIGURE 2(a) - INSERTS: PLUGS AND RECEPTACLES (CONT.)

PLUG, 352 CONTACTS

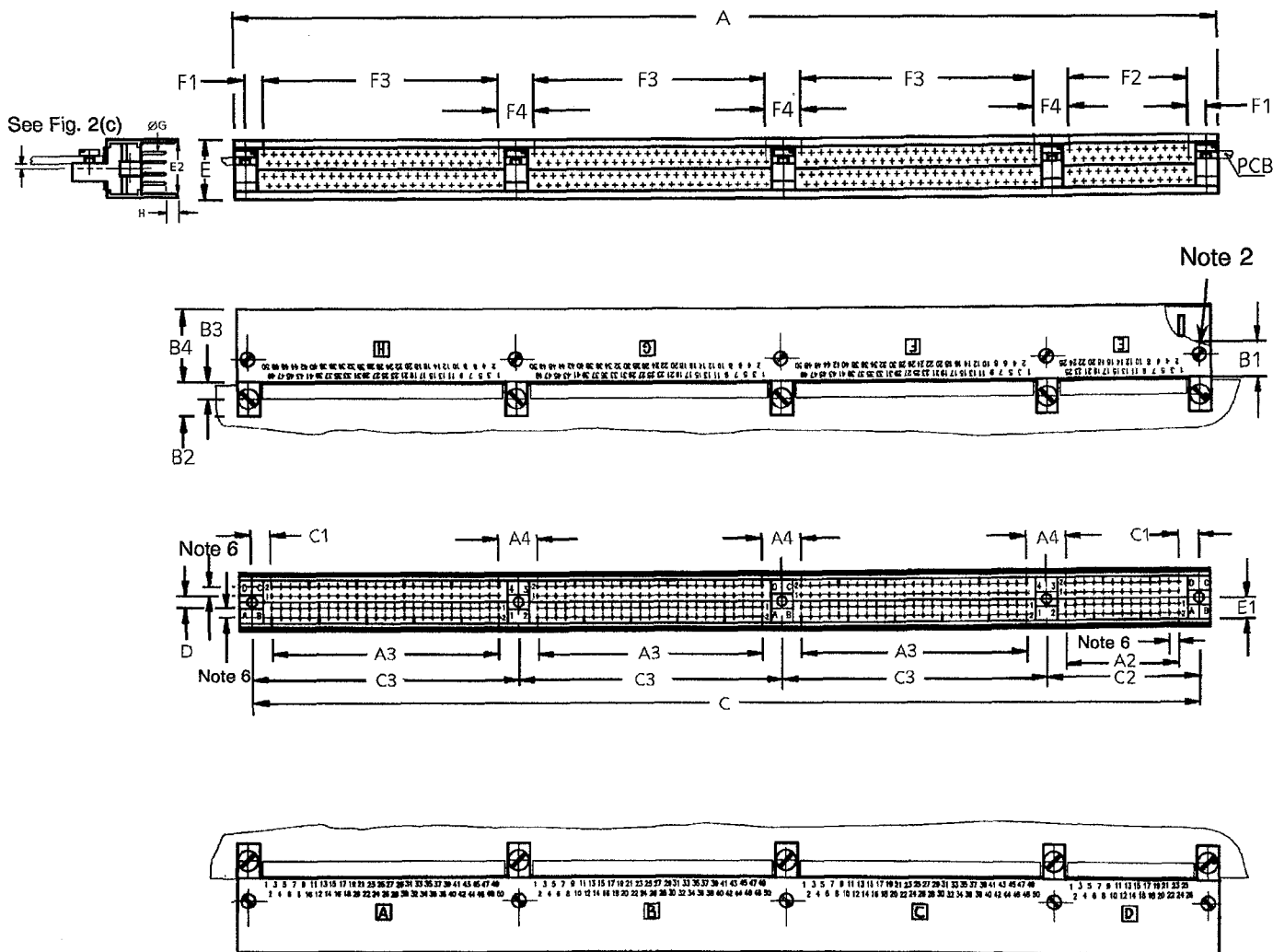

Symbol/ Dim. (1)	A	<u>A2</u>	<u>A3</u>	<u>A4</u>	B1	B2	B3	B4	C	<u>C1</u>	<u>C2</u>	<u>C3</u>	D	E	E1	E2	<u>F1</u>	<u>F2</u>	<u>F3</u>	<u>F4</u>	ØG	H
MIN.	196.2	22.66	45.52	7.74	7.0	-	3.5	14.3	191.62	3.77	30.65	53.51	2.34	-	5.05	10.20	3.29	23.61	46.47	6.79	0.42	2.0
MAX.	196.5	23.06	45.92	8.14	7.2	7.4	3.6	14.6	191.92	4.17	30.95	53.81	2.74	12	5.25	10.45	3.69	24.01	46.87	7.19	0.44	3.0

NOTES

1. All dimensions are in millimetres.
2. Torque : 10N.cm.
3. Underlined dimensions, in table, are critical to ensure intermateability.
4. The front of the insert shall be marked with the minimum marking shown.
5. Orientation of labelling of contacts and guiding devices is not a true representation.
6. Pitch : 1.905mm.



FIGURE 2 - PHYSICAL DIMENSIONS (CONT.)

FIGURE 2(b) - GUIDING AND LOCKING DEVICES

CODE 110

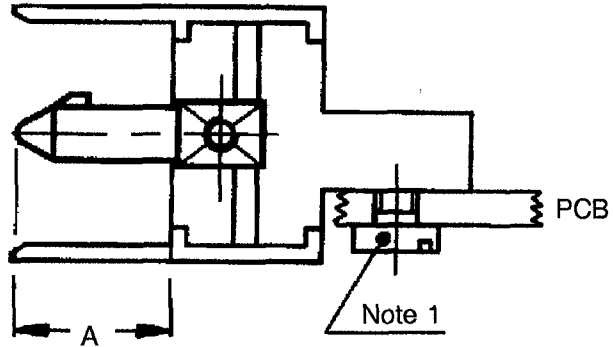

SYMBOL	MILLIMETRES	
	MIN.	MAX.
A	7.00	7.35

NOTES

1. Torque 15N.cm.

CODE 111

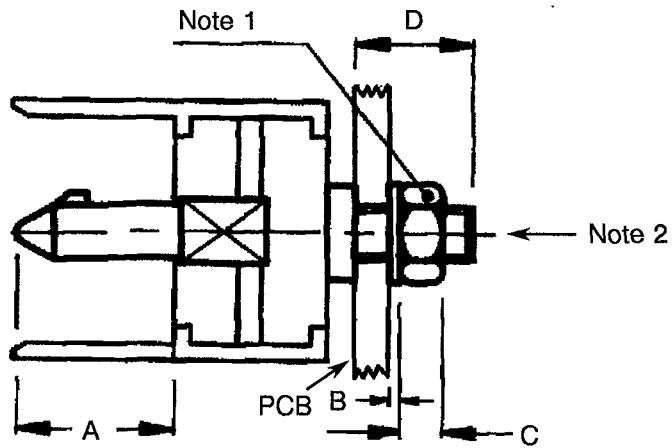

SYMBOL	MILLIMETRES	
	MIN.	MAX.
A	7.00	7.35
B	0.45	0.55
C	1.90	2.10
D	-	5.50

NOTES

1. Torque 25N.cm.
2. M2.50.

FIGURE 2 - PHYSICAL DIMENSIONS (CONT.)

FIGURE 2(b) - GUIDING AND LOCKING DEVICES (CONT.)

CODE 121

SYMBOL	MILLIMETRES	
	MIN.	MAX.
B	0.45	0.55
C	1.90	2.10
D	-	5.50

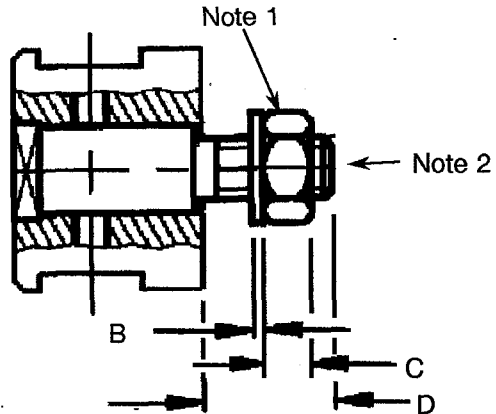

NOTES

1. Torque 25N.cm.
2. M2.50.

CODES 124 AND 134

SYMBOL	MILLIMETRES		NOTES
	MIN.	MAX.	
D	-	7.00	Code 124
ØE	2.45	2.55	
F	-	6.00	Code 134
F	-	6.60	
G	2.60	2.70	

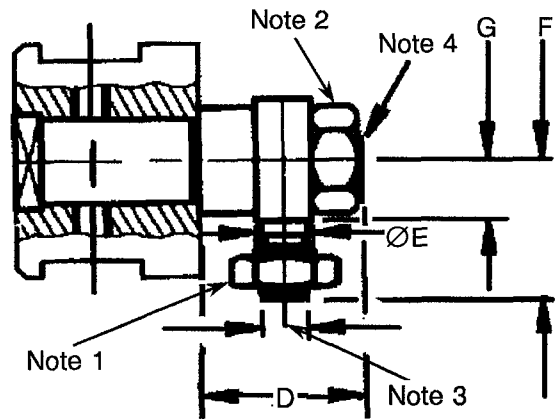

NOTES

1. Torque 15N.cm.
2. Torque 25N.cm.
3. M2.00.
4. M2.50.



FIGURE 2 - PHYSICAL DIMENSIONS (CONT.)

FIGURE 2(b) - GUIDING AND LOCKING DEVICES (CONT.)

CODE 201

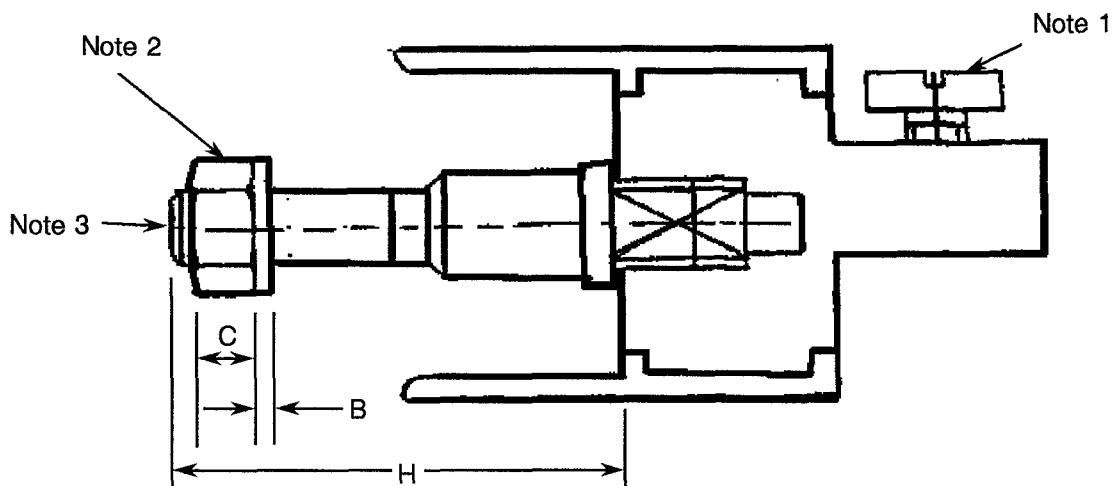

SYMBOL	MILLIMETRES	
	MIN.	MAX.
B	0.45	0.55
C	1.90	2.10
H	-	15.00

NOTES

1. Torque 15N.cm.
2. Torque 25N.cm.
3. M2.50.



FIGURE 2 - PHYSICAL DIMENSIONS (CONT.)

FIGURE 2(c) - CONTACT MOUNTING CONFIGURATIONS

VIEW OF REAR PART OF CONNECTOR

CODE 10, 11 AND 12

RIGHT-ANGLE SOLDER CONTACTS

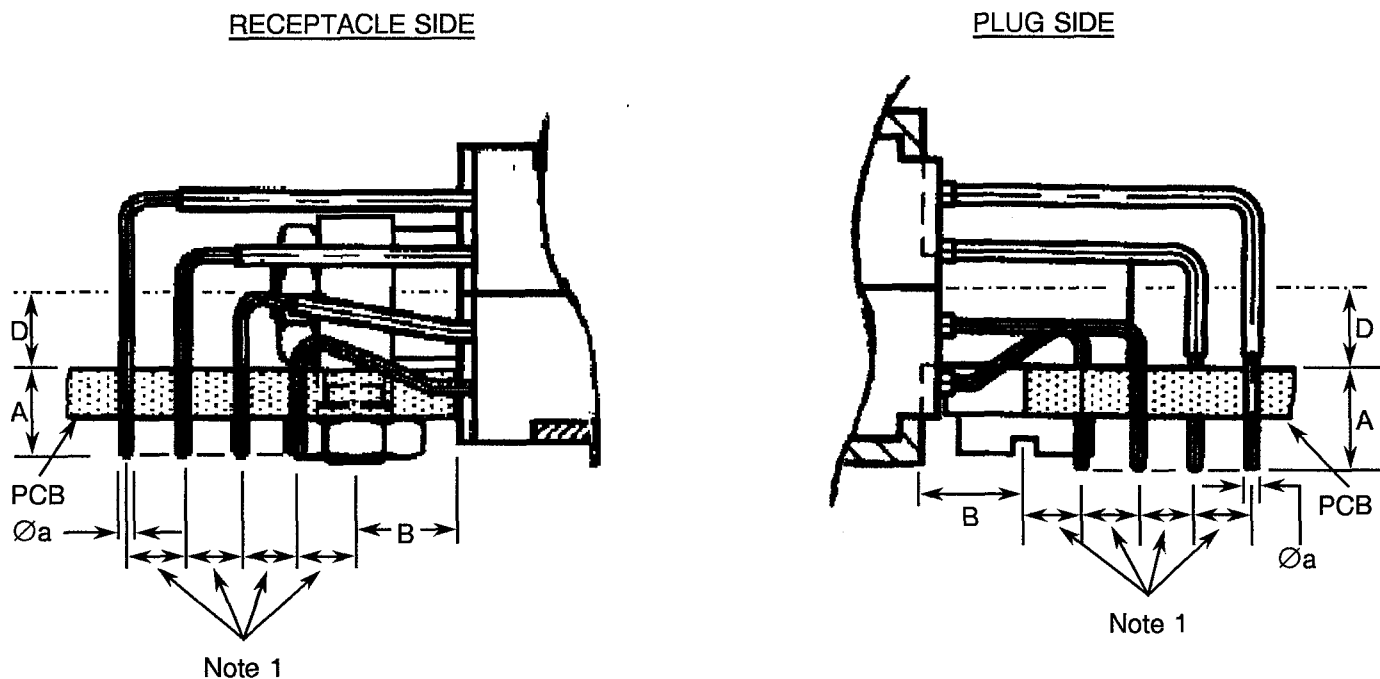

SYMBOL	CODE 10 Plug and Receptacle		CODE 11 Receptacle Only		CODE 12 Plug Only		
	MILLIMETRES						
	MIN.	MAX.	MIN.	MAX.	MIN.	MAX.	
A	2.60	3.80	3.10	4.30	4.10	5.30	
B	PLUG	3.40	3.60	-	-	3.40	3.60
	RECEPT.	3.20	3.80	3.20	3.80	-	-

SYMBOL	MILLIMETRES	
	MINIMUM	MAXIMUM
Øa	0.36	0.44
D	2.60	2.70

NOTES

1. Pitch : 1.905mm.



FIGURE 2 - PHYSICAL DIMENSIONS (CONT.)

FIGURE 2(c) - CONTACT MOUNTING CONFIGURATIONS (CONT.)

VIEW OF REAR PART OF CONNECTOR

CODE 30 AND 31

STRAIGHT SOLDER CONTACT



SYMBOL	CODE 30 Plug and Receptacle		CODE 31 Receptacle		CODE 31 Plug	
	MILLIMETRES					
	MIN.	MAX.	MIN.	MAX.	MIN.	MAX.
A	3.50	4.00	6.10	6.60	4.60	5.10

SYMBOL	MILLIMETRES	
	MINIMUM	MAXIMUM
Øa	0.36	0.44

NOTES

1. Pitch : 1.905mm.
2. Pitch : 2.54mm.

CODE 91 - SAVER

SYMBOL	MILLIMETRES	
	MINIMUM	MAXIMUM
A	4.50	5.50
Øa	0.42	0.44

NOTES

1. Pitch : 1.905mm.
2. Pitch : 2.54mm.

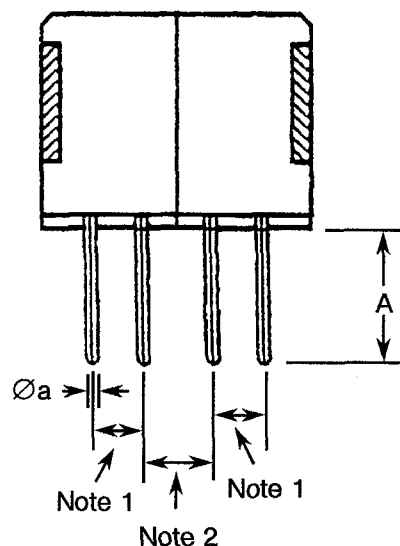



FIGURE 2 - PHYSICAL DIMENSIONS (CONT.)

FIGURE 2(c) - CONTACT MOUNTING CONFIGURATIONS (CONT.)

VIEW OF REAR PART OF CONNECTOR

CODE 43

SURFACE MOUNT - APPLICABLE TO PLUGS ONLY

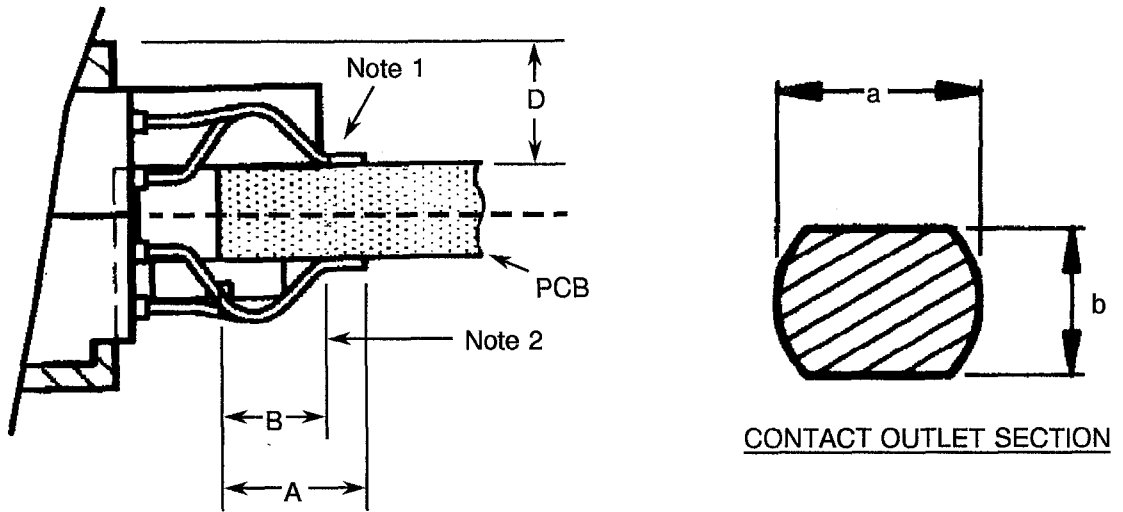

SYMBOL	MILLIMETRES		NOTES
	MIN.	MAX.	
a	0.25	0.45	
A	-	5.50	
b	0.20	0.40	
B	3.00	4.10	
D	-	4.80	

NOTES

1. See section. Pitch : 0.9525mm.
2. Contact point.

FIGURE 2 - PHYSICAL DIMENSIONS (CONT.)

FIGURE 2(c) - CONTACT MOUNTING CONFIGURATIONS (CONT.)

VIEW OF REAR PART OF CONNECTOR

CODE 45 AND 47

SURFACE MOUNT OFF CENTRE - APPLICABLE TO PLUGS ONLY

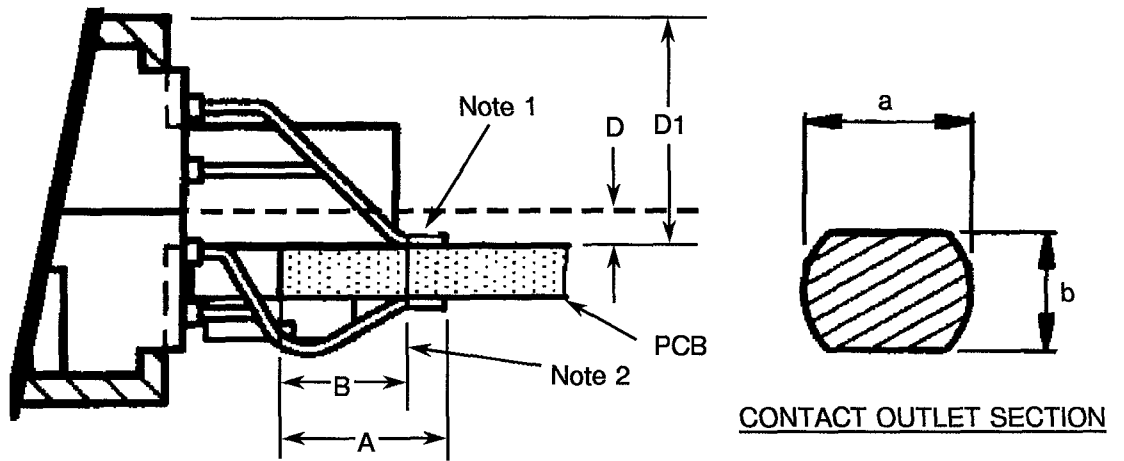

SYMBOL	CODE 45		CODE 47	
	MILLIMETRES			
	MIN.	MAX.	MIN.	MAX.
A	-	5.00	-	5.00

SYMBOL	MILLIMETRES	
	MINIMUM	MAXIMUM
a	0.25	0.45
b	0.20	0.40
B	3.00	4.10
D	0.90	1.20
D1	-	7.00

NOTES

1. See section. Pitch : 0.9525mm.
2. Contact point.

**4. REQUIREMENTS****4.1 GENERAL**

The complete requirements for procurement of the connectors specified herein are stated in this specification and ESA/SCC Generic Specification No. 3401. Deviations from the Generic Specification, applicable to this specification only, are listed in Para. 4.2

Deviations from the applicable Generic Specification and this Detail Specification, formally agreed with specific Manufacturers on the basis that the alternative requirements are equivalent to the ESA/SCC requirements and do not affect the components' reliability, are listed in the appendices attached to this specification.

4.2 DEVIATIONS FROM GENERIC SPECIFICATION**4.2.1 Deviations from Special In-process Controls**

None.

4.2.2 Deviations from Final Production Tests (Chart II)

- (a) Para. 9.1.1.4, Mated Shell Conductivity: Not applicable.
- (b) Para. 9.4, Contact Capability: Sampling in accordance with Para. 9.6 of ESA/SCC No. 3401.
- (c) Para. 9.5, Magnetism Level: Not applicable.
- (d) Para. 9.9, Seal Test: Not applicable.

4.2.3 Deviations from Burn-in and Electrical Measurements (Chart III)

Not applicable.

4.2.4 Deviations from Qualification Tests (Chart IV)

- (a) Para. 9.1.1.4, Mated Shell Conductivity: Not applicable.
- (b) Para. 9.9, Seal Test: Not applicable.
- (c) Para. 9.15, Joint Strength: Not applicable.
- (d) Para. 9.24, Jackscrew Retention: Not applicable.
- (e) Para. 9.27, Maintenance Ageing: Not applicable.
- (f) Para. 9.30, Probe Damage: Not applicable.

4.2.5 Deviations from Lot Acceptance Tests (Chart V)

- (a) Para. 9.1.1.4, Mated Shell Conductivity: Not applicable.
- (b) Para. 9.9, Seal Test: Not applicable.
- (c) Para. 9.15, Joint Strength: Not applicable.
- (d) Para. 9.27, Maintenance Ageing: Not applicable.
- (e) Para. 9.30, Probe Damage: Not applicable.



4.3 MECHANICAL REQUIREMENTS

4.3.1 Dimension Check

The dimensions of the connectors specified herein shall be verified in accordance with the requirements set out in Para. 9.6 of ESA/SCC Generic Specification No. 3401 and shall conform to those shown in Figure 2 of this specification. Only the following dimensions shall be checked during procurement:-

Figure 2(a) - Between centres of guiding or locking device. (Dimensions C, C2 and C3).

- Dimension E1 (where applicable).

Figure 2(b) - Protrusion of guiding/locking devices.

- Overall dimensions of guiding/locking devices.

Figure 2(c) - All dimensions, except pitch.

4.3.2 Weight

The maximum weight of the connectors with contacts, guiding and locking devices specified herein, shall be as specified in Table 1(a).

4.3.3 Contact Capability

For the purpose of this test, the pick-up and drop weights shall be as follows.

	Pick-up Weight	Drop Weight
Weight (g)	5.0	70
Pin Diameter (mm)	0.415 - 0.420	0.440 - 0.445
Insertion Depth (mm)	5.0	5.0

4.3.4 Contact Retention (In Insert)

The contact retention force (compression) within the insert shall be 40N.

4.3.5 Mating and Unmating Forces

The forces applied for mating and unmating of the connectors shall not exceed the values specified in Table 1(a).

4.3.6 Insert Retention (In Shell)

Connector inserts shall withstand a pressure of 25N/cm² without being dislodged from the shell.

4.3.7 Jackscrew Retention

Not applicable.

4.3.8 Contact Insertion and Withdrawal Forces

Not applicable.

4.3.9 Engagement and Separation Forces

The diameter of the test pin and the engagement and separation forces of the female contacts shall be as specified hereunder.

	Diameter (mm)		Engagement Max. (N)	Separation (N)	
	Min.	Max.		Min.	Max.
Minimum Diameter Test Pin	0.415	0.420	-	0.05	-
Maximum Diameter Test Pin	0.440	0.445	0.70	-	0.70

4.3.10 Oversize Pin Exclusion

The diameter of the test pin shall be 0.598mm minimum and 0.602mm maximum and the force applied to it shall be 0.7N.

4.3.11 Probe Damage

Not applicable.

4.3.12 Solderability

No special conditions.

4.4 MATERIALS AND FINISHES

The materials and finishes shall be as specified herein. Where a definite material is not specified, a material which will enable the contacts specified herein to meet the performance requirements of this specification shall be used. Acceptance or approval of any constituent material does not guarantee acceptance of the finished product.

4.4.1 Shells

Shells shall be made of aluminum alloy with an appropriate surface treatment against corrosion.

4.4.2 Inserts

The inserts shall be made of glass fibre-filled diallylphthalate resin.

4.4.3 Contacts

4.4.3.1 Body

The contact body shall be made of copper alloy.

- Male Contact and Saver

The plating shall be 1.27µm minimum gold over 1.27µm minimum nickel.

- Female Contact

The plating shall be 0.25µm minimum gold over 1.27µm minimum nickel.

4.4.3.2 Female Contact Wire

The wire shall be made of copper alloy.

The plating shall be 1.27µm minimum gold over 0.20µm minimum nickel.



4.4.3.3 Female Contact Sleeve

The sleeve shall be made of copper alloy. The plating shall be 0.25µm minimum gold over 0.8µm minimum nickel.

4.4.3.4 Tinned Terminations (Insert Codes 46 and 57)

Solder dipped, tin/lead 63/37, minimum thickness 1.0µm, minimum length 3.5mm.

4.4.4 Contact Retaining Clip

Not applicable.

4.4.5 Guiding and Locking Devices

Guiding and locking devices shall be made of brass (nickel-plated), stainless steel or arcap alloy.

4.4.6 Magnetism Level

Not applicable.

4.5 MARKING

4.5.1 General

The marking of all components delivered to this specification shall be in accordance with the requirements of ESA/SCC Basic Specification No. 21700 and the following paragraphs. When the component is too small to accommodate all of the marking specified. as much as space permits shall be marked and the marking information, in full, shall accompany the component in its primary package.

The information to be marked and the order of precedence, shall be as follows:-

- (a) Contact Identification.
- (b) The SCC Component Number.
- (c) Characteristics.
- (d) Traceability information.

4.5.2 Contact Position

Contact position shall be marked on the inserts in accordance with Figure 2(a).

4.5.3 The SCC Component Number

Each component shall bear the SCC Component Number which shall be constituted and marked as follows:-

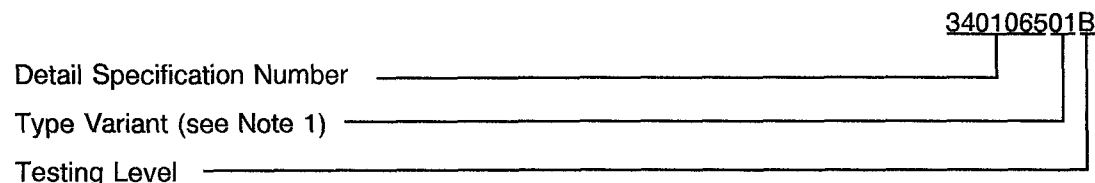

NOTES

1. Marking of the Type Variant is mandatory. No further reference to type variants is made in this specification.



4.5.4 Characteristics

The characteristics to be marked in the following order of precedence are:-

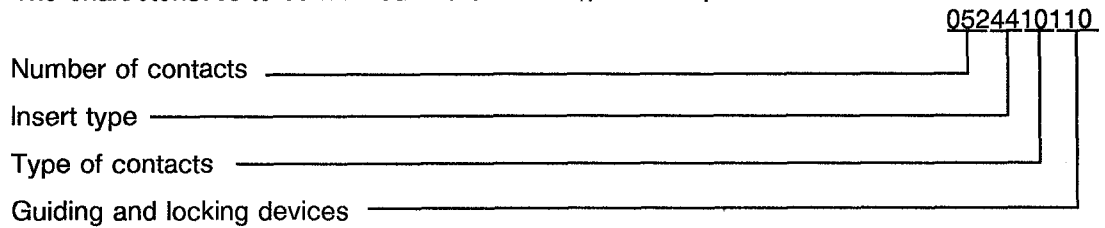

4.5.4.1 Number of Contacts

052 - 100 - 152 - 200 - 252 - 300 - 352 - 400.

4.5.4.2 Insert

Inserts shall be designated by the following code numbers.

Code No.	Description
44	Receptacle (female contacts)
46	Receptacle (female contact pre-tinned termination)
55	Plug (male contacts)
57	Plug (male contact pre-tinned termination)

4.5.4.3 Contacts

Contact rear configurations shall be designated by the codes given in Table 1(a) and Figure 2(c).

4.5.4.4 Guiding and Locking Devices

Guiding and locking devices shall be designated by the codes given in Figure 2(b).

N.B.

If the purchase order does not specify any guiding or locking devices, receptacles shall be delivered without.

4.5.5 Traceability Information

Traceability information shall be marked in accordance with the requirements of ESA/SCC Basic Specification No. 21700.

4.6 ELECTRICAL MEASUREMENTS

4.6.1 Electrical Measurements at Room Temperature

The parameters to be measured in respect of electrical characteristics are scheduled in Table 2. Unless otherwise specified, the measurements shall be performed at $T_{amb} = +22 \pm 3$ °C.

4.6.2 Electrical Measurements at High and Low Temperatures (Table 3)

Not applicable.

4.6.3 Circuits for Electrical Measurements (Figure 4)

Not applicable.

4.7 BURN-IN AND ELECTRICAL MEASUREMENTS

Not applicable.



4.8 ENVIRONMENTAL AND ENDURANCE TESTS (CHARTS IV AND V OF ESA/SCC GENERIC SPECIFICATION No. 3401)

4.8.1 Measurements and Inspections on Completion of Environmental Tests

The parameters to be measured and inspections to be performed on completion of environmental testing are scheduled in Table 6. Unless otherwise specified, the measurements shall be performed at $T_{amb} = +22 \pm 3$ °C.

4.8.2 Measurements and Inspections at Intermediate Points during Endurance Tests

Not applicable.

4.8.3 Measurements and Inspections on Completion of Endurance Tests

The parameters to be measured and inspections to be performed on completion of endurance testing are scheduled in Table 6. Unless otherwise specified, the measurements shall be performed at $T_{amb} = +22 \pm 3$ °C.

4.8.4 Conditions for Operating Life Tests (Part of Endurance Testing)

Not applicable.

4.8.5 Electrical Circuit for Operating Life Tests (Figure 5)

Not applicable.

4.8.6 Conditions for High Temperature Storage Test (Part of Endurance Testing)

The requirements for the high temperature storage test are specified in Section 9 of ESA/SCC Generic Specification No. 3401. The conditions for high temperature storage testing shall be the maximum storage temperature specified in Table 1(b) of this specification.

**TABLE 2 - ELECTRICAL MEASUREMENTS AT ROOM TEMPERATURE**

No.	CHARACTERISTICS	SYMBOL	ESA/SCC 3401 TEST METHOD	TEST CONDITION	LIMITS		UNIT
					MIN.	MAX.	
1	Insulation Resistance	Ri	Para 9.1.1.1	Para 9.1.1.1	10 000	-	MΩ
2	Voltage Proof Leakage Current (Sea Level)	I _L	Para 9.1.1.2	800 Vrms	-	1.0	mA
3	Mated Shell Conductivity (Voltage Drop)	Vd	Para 9.1.1.4	Para 9.1.1.4	Not Applicable		mV
4	Contact Resistance (Low Level Current)	Rcl	Para 9.1.1.3	All	-	12	mΩ
5	Contact Resistance (Rated Current)	Rcr	Para 9.1.1.3	2.0A	-	12	mΩ

TABLES 3, 4 AND 5

Not applicable.



SCC

ESA/SCC Detail Specification
No. 3401/065

PAGE 38
ISSUE 1

TABLE 6 - MEASUREMENTS AND INSPECTIONS ON COMPLETION OF ENVIRONMENTAL AND ENDURANCE TESTING

NO.	ESA/SCC GENERIC NO. 3401		MEASUREMENTS AND INSPECTIONS		SYMBOL	LIMITS		UNIT
	ENVIRONMENTAL AND ENDURANCE TESTS (1)	TEST METHOD AND CONDITIONS	IDENTIFICATION	CONDITIONS		MIN	MAX	
01	Seal Test	Para. 9.9	Not applicable			Not applicable		
02	Wiring	Para. 9.10				-	-	
03	Vibration	Para. 9.11	Initial Measurements Coupling Screw(s) Unlocking Torque Final Measurements Full Engagement Coupling Screw(s) Unlocking Torque Drift Visual Examination	-	-	Record Values		
			Visual Examination	-	Δ	-25	+25	%
04	Shock or Bump	Para. 9.12	Full Engagement Visual Examination	-		-	-	
05	Climatic Sequence	Para. 9.13	Dry Heat Insulation Resistance Low Air Pressure Voltage Proof Leakage Curr. Damp Heat Insulation Resistance External Visual Inspection Insulation Resistance Voltage Proof Leakage Curr.	Table 2 Item 1 Figure 1 Immediately after test Table 2 Item 1 After 1-24 hrs Recovery ESA/SCC 3401 Para. 9.7 Table 2 Item 1 Table 2 Item 2	Ri I _L Ri - Ri I _L	1 000 ESA/SCC 3401 Para. 9.13.5 100 ESA/SCC 3401 Para. 9.7 Table 2 Item 1 Table 2 Item 2	- - - -	MΩ MΩ
06	Plating Thickness	Para. 9.14	Thickness			Para. 4.4.3 of this spec.		
07	Joint Strength	Para. 9.15	ESA/SCC 3401 Para. 9.15			Not applicable		
08	Rapid Change of Temperature	Para. 9.16	Visual Examination Insulation Resistance Voltage Proof Leakage Curr.	- Table 2 Item 1 Table 2 Item 2	- Ri I _L	- Table 2 Item 1 Table 2 Item 2		
09	Contact Retention (in insert)	Para. 9.17 and Para. 4.3.4 of this spec.	Contact Displacement			ESA/SCC 3401 Para. 9.17		
10	Endurance	Para. 9.18	Initial Measurements Mating/Unmating Forces Low Level Contact Resist Mated Shell Conductivity Final Measurements Visual Examination Mating/Unmating Forces Low Level Contact Resistance Drift Mated Shell Conductivity Insulation Resistance Voltage Proof Leakage Curr.	Table 2 Item 4 Table 2 Item 3 - Table 2 Item 4 Table 2 Item 3 Table 2 Item 1 Table 2 Item 2	F Rcl Vd - F ΔRcl Vd Ri I _L	Para. 4.3.5 of this spec. Record Values Not applicable - Para. 4.3.5 of this spec. - 4.0 Not applicable Table 2 Item 1 Table 2 Item 2	- - - mΩ	

NOTES 1. The tests in this table refer to either Chart IV or V and shall be used as applicable.



TABLE 6 - MEASUREMENTS AND INSPECTIONS ON COMPLETION OF ENVIRONMENTAL AND ENDURANCE TESTING (CONT'D)

NO.	ESA/SCC GENERIC NO. 3401		MEASUREMENTS AND INSPECTIONS		SYMBOL	LIMITS		UNIT
	ENVIRONMENTAL AND ENDURANCE TESTS (1)	TEST METHOD AND CONDITIONS	IDENTIFICATION	CONDITIONS		MIN	MAX	
11	Permanence of Marking	Para. 9.19	As applicable		-	-	-	
12	Mating/Unmating Forces	Para. 9.20	Force		F	Para. 4.3.5 of this spec.		
13	High Temperature Storage	Para. 9.21	Initial Measurements Low Level Contact Resis. Mated Shell Conductivity Final Measurements Visual Examination Mating/Unmating Forces Low Level Contact Resistance Drift Rated Current Contact Resis. Mated Shell Conductivity Insulation Resistance Voltage Proof Leakage Curr. Contact Retention (in insert)	Table 2 Item 4 Table 2 Item 3 - Table 2 Item 4 Table 2 Item 5 Table 2 Item 3 Table 2 Item 1 Table 2 Item 2 Para. 4.3.4 of this spec.	Rcl Vd - F ΔRcl Rcr Vd Ri I _L	Record Values Not applicable - - Para. 4.3.5 of this spec. - 4.0 Table 2 Item 5 Not applicable Table 2 Item 1 Table 2 Item 2 ESA/SCC 3401 Para. 9.17	mΩ	
14	Corrosion	Para. 9.22	Visual Examination	-	-	Not applicable		
15	Insert Retention (in shell)	Para. 9.23 & Para. 4.3.6 of this spec.	Visual Examination	-	-	Para. 4.3.6		
16	Jackscrew Retention	Para. 9.24 & Para. 4.3.7 of this spec.	Visual Examination	-	-	Not applicable		
17	High Temperature Measurements	Para. 9.25	Insulation Resistance	Table 2 Item 1	Ri	500	-	MΩ
18	Overload Test	Para. 9.26	Internal Temperature Rated Current Contact Resis. Mated Shell Conductivity Insulation Resistance Voltage Proof Leakage Curr.	Table 2 Item 5 Table 2 Item 3 Table 2 Item 1 Table 2 Item 2	T Rcr Vd Ri I _L	-	+ 100	°C
19	Maintenance Aging	Para. 9.27	Visual Examination Contact Retention (in insert) Contact Insertion & Withdrawal Forces	- Para. 4.3.4 of this spec Para. 4.3.8 of this spec	-	-	-	-
20	Engage/Separation Forces	Para. 9.28 & Para. 4.3.9 of this spec.	Force		F	Para. 4.3.9		
21	Oversize Pin Exclusion	Para. 9.29 & Para. 4.3.10 of this spec.				ESA/SCC 3401 Para. 9.29		
22	Probe Damage	Para. 9.30 & Para. 4.3.11 of this spec.	Contact Separation Force	Para. 4.3.9 of this spec.		Not applicable		
23	Solderability	Para. 9.31 & Para. 4.3.12 of this spec.				ESA/SCC 3401 Para. 9.31		

NOTES

1. The tests in this table refer to either Chart IV or V and shall be used as applicable.