



**european space agency
agence spatiale européenne**

Pages 1 to 23

**CONNECTOR RECEPTACLES, ELECTRICAL,
CIRCULAR, TRIPLE-START SELF-LOCKING COUPLING,
SCOOP-PROOF, P.C.B.
NON-REMOVABLE CONTACTS,
BASED ON MIL-C-38999 SERIES III
ESA/SCC Detail Specification No. 3401/070**

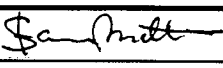
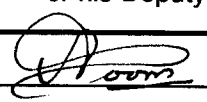

**space components
coordination group**

Issue/Rev.	Date	Approved by	
		SCCG Chairman	ESA Director General or his Deputy
Issue 1	June 2000		



SCC

ESA/SCC Detail Specification
No. 3401/070

PAGE 2

ISSUE 1

Rev. Letter	Rev. Date	Reference	CHANGE Item	Approved DCR No.



TABLE OF CONTENTS

	<u>Page</u>
1. <u>GENERAL</u>	5
1.1 Scope	5
1.2 Range of Components	5
1.3 Maximum Ratings	5
1.4 Parameter Derating Information	5
1.5 Physical Dimensions	5
2. <u>APPLICABLE DOCUMENTS</u>	5
3. <u>TERMS, DEFINITIONS, ABBREVIATIONS, SYMBOLS AND UNITS</u>	5
4. <u>REQUIREMENTS</u>	14
4.1 General	14
4.2 Deviations from Generic Specification	14
4.2.1 Deviations from Special In-process Controls	14
4.2.2 Deviations from Final Production Tests	14
4.2.3 Deviations from Burn-in and Electrical Measurements	14
4.2.4 Deviations from Qualification Tests	14
4.2.5 Deviations from Lot Acceptance Tests	14
4.3 Mechanical Requirements	15
4.3.1 Dimension Check	15
4.3.2 Weight	15
4.3.3 Contact Capability	15
4.3.4 Contact Retention	15
4.3.5 Mating and Unmating Forces	15
4.3.6 Insert Retention	15
4.3.7 Jackscrew Retention	15
4.3.8 Contact Insertion and Withdrawal Forces	15
4.3.9 Engagement and Separation Forces	15
4.3.10 Oversize Pin Exclusion	15
4.3.11 Probe Damage	15
4.3.12 Solderability	15
4.4 Materials and Finishes	15
4.4.1 Shell and Nuts	15
4.4.2 Inserts	15
4.4.3 Contacts	16
4.4.4 Contact Retaining Clip	16
4.4.5 Guiding and Locking Devices	16
4.4.6 Magnetism Level	16
4.5 Marking	16
4.5.1 General	16
4.5.2 Contact Identification	16
4.5.3 The SCC Component Number	16
4.5.4 Characteristics	17
4.5.5 Traceability Information	18
4.6 Electrical Measurements	18
4.6.1 Electrical Measurements at Room Temperature	18
4.6.2 Electrical Measurements at High and Low Temperatures	18
4.6.3 Circuit for Electrical Measurements	18
4.7 Burn-in and Electrical Measurements	18



	<u>Page</u>
4.8 Environmental and Endurance Tests	20
4.8.1 Measurements and Inspections on Completion of Environmental Tests	20
4.8.2 Measurements and Inspections at Intermediate Points during Endurance Tests	20
4.8.3 Measurements and Inspections on Completion of Endurance Tests	20
4.8.4 Conditions for Operating Life Test	20
4.8.5 Electrical Circuits for Operating Life Test	20
4.8.6 Conditions for High Temperature Storage Test	20

TABLES

1(a) Range of Components	6
1(b) Maximum Ratings	6
2 Electrical Measurements at Room Temperature	19
3 Not applicable	N/A
4 Not applicable	N/A
5 Not applicable	N/A
6 Measurements and Inspections on Completion of Environmental and Endurance Tests	21

FIGURES

1 Parameter Derating Information	7
2 Physical Dimensions	8
2(a) Physical Dimensions - Receptables	8
2(b) Physical Dimensions - Contact Arrangements	10
2(c) Physical Dimensions - Clocking Positions	13

APPENDICES (Applicable to specific Manufacturers only)

None.

**1. GENERAL****1.1 SCOPE**

This specification details the ratings, physical and electrical characteristics, test and inspection data for Connector Receptacles, Electrical, Circular, Triple-Start Self-Locking Coupling, Scoop-proof, P.C.B. Shouldered Posted Non-Removable Contacts, based on MIL-C-38999 Series III.

It shall be read in conjunction with:

- ESA/SCC Generic Specification No. 3401, Connectors, Electrical, Non-Filtered, Circular and Rectangular.
- ESA/SCC Detail Specification No. 3401/056, Connectors, Electrical, Circular, Triple-Start Self-Locking Coupling, Scoop-Proof, Removable Crimp Contacts, Based on MIL-C-38999 Series III.
- ESA/SCC Detail Specification No. 3401/058, Contacts, Electrical, Crimp, for 3401/052 and /056 Connectors.

the requirements of which are supplemented herein.

1.2 RANGE OF COMPONENTS

The different sizes of connectors specified herein, which are also covered by this specification, together with their mechanical characteristics, are given in Table 1(a).

1.3 MAXIMUM RATINGS

The maximum ratings, which shall not be exceeded at any time during use or storage, applicable to the connectors specified herein, are scheduled in Table 1(b).

1.4 PARAMETER DERATING INFORMATION

The applicable derating information for the connectors specified herein is shown in Figure 1.

1.5 PHYSICAL DIMENSIONS

The physical dimensions of the connectors specified herein are shown in Figure 2.

2. APPLICABLE DOCUMENTS

The following documents form part of this specification and shall be read in conjunction with it:-

- (a) ESA/SCC Generic Specification No. 3401, Connectors, Electrical, Non-Filtered, Circular and Rectangular.
- (b) ESA/SCC Detail Specification No. 3401/056, Connector, Electrical, Circular, Triple-Start Self-Locking Coupling, Scoop-Proof, Removable Crimp Contacts, Based on MIL-C-38999 Series III.
- (c) ESA/SCC Detail Specification No. 3401/058, Contacts, Electrical, Crimp, for 3401/052 and /056 Connectors.
- (d) MIL-STD-1560, Insert Arrangements for MIL-C-38999 and MIL-C-27599 Electrical Circular Connectors.
- (e) MIL-STD-1344, Test Methods for Electrical Connectors.

3. TERMS, DEFINITIONS, ABBREVIATIONS, SYMBOLS AND UNITS

For the purpose of this specification, the terms, definitions, abbreviations, symbols and units specified in ESA/SCC Basic Specification No. 21300 shall apply.

**TABLE 1(a) - RANGE OF COMPONENTS**

SHELL STYLE	SHELL SIZE	MAX. WEIGHT (g)		TIGHT. TORQUE FOR MTG NUT SHELL 07 MAX (Nm)
		SHELL TYPE		
		00	07	
Receptacle	09	14	18	6.0
Receptacle	11	20	23	8.0
Receptacle	13	27	31	10
Receptacle	15	35	44	13
Receptacle	17	40	56	16
Receptacle	19	55	64	18
Receptacle	21	70	80	20
Receptacle	23	78	88	22
Receptacle	25	88	100	24

TABLE 1(b) - MAXIMUM RATINGS

NO	CHARACTERISTICS	SYMBOL	MAXIMUM RATING	UNIT	REMARKS
1	Working Voltage (1) (Sea Level) Service rating M Service rating I Service rating II	U_R	325 450 575	Vrms	
2	Operating Temperature Range	T_{op}	- 65 to +200	°C	
3	Storage Temperature Range	T_{stg}	- 65 to +200	°C	
4	Tightening Torque for Mounting Nut Shell 07	T_q	See Table 1(a)		
5	Rated Current Contact Size 22 Contact Size 20 Contact Size 16	I_R	3.0 5.0 10	A	
6	Soldering Temperature	T_{sol}	+ 260	°C	Note 2

NOTES

1. See Para. 4.5.4.3.
2. Duration 10 seconds maximum and the same contact shall not be resoldered until 3 minutes have elapsed.



FIGURE 1 - PARAMETER DERATING INFORMATION

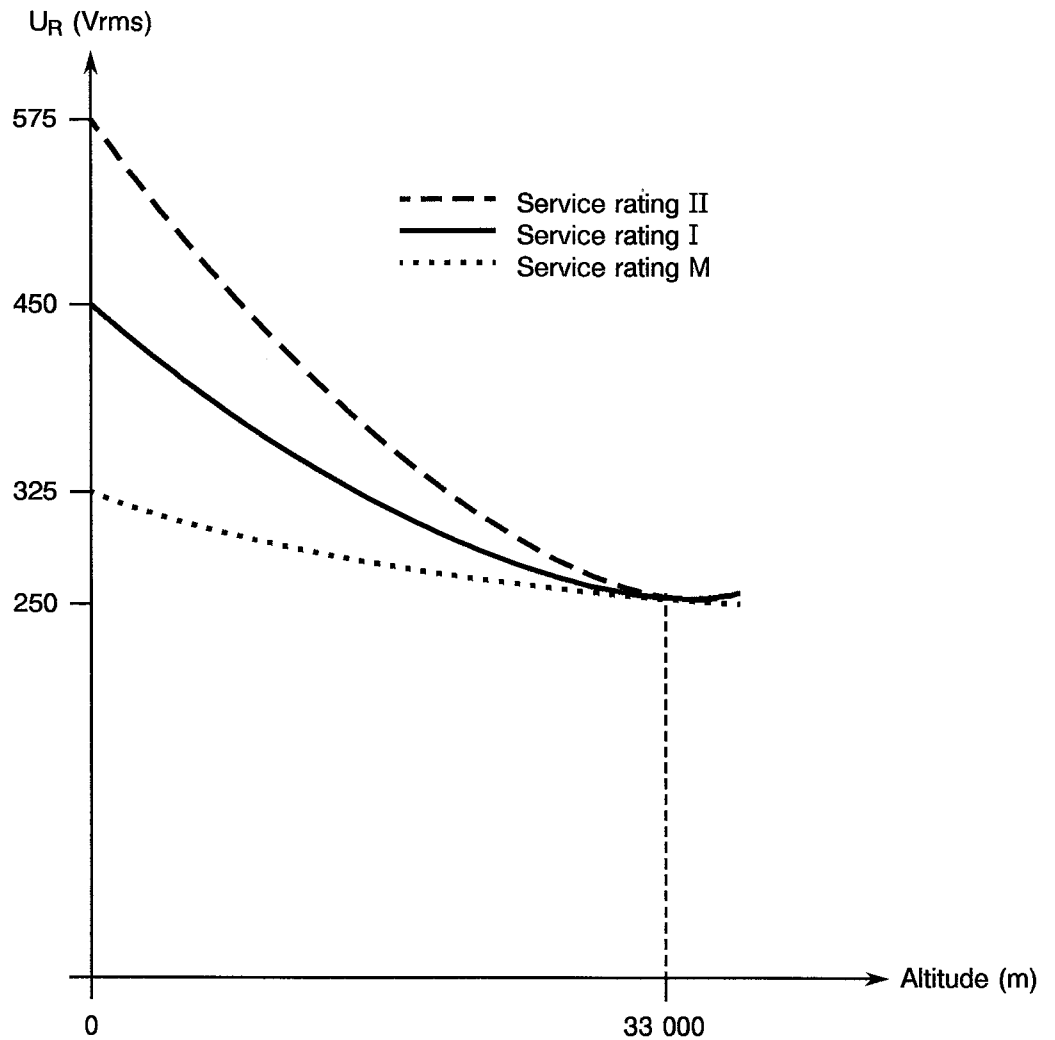

Working Voltage versus Altitude



FIGURE 2 - PHYSICAL DIMENSIONS

FIGURE 2(a) - RECEPTACLES

Shell type 00: Square flange receptacle

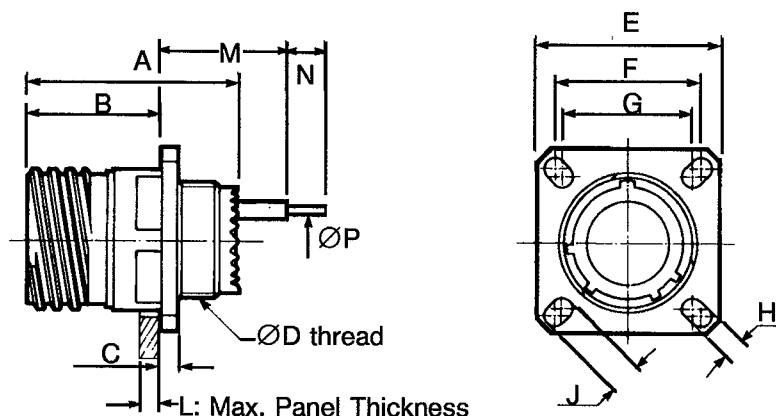

SHELL SIZE	09		11		13		15		17		19		21		23		25	
	MIN	MAX	MIN	MAX	MIN	MAX	MIN	MAX	MIN	MAX	MIN	MAX	MIN	MAX	MIN	MAX	MIN	MAX
A	-	31.50	-	31.50	-	31.50	-	31.50	-	31.50	-	31.50	-	31.50	-	31.50	-	31.50
B	-	20.90	-	20.90	-	20.90	-	20.90	-	20.90	-	20.90	-	20.10	-	20.10	-	20.10
C	2.10	2.50	2.10	2.50	2.10	2.50	2.10	2.50	2.10	2.50	2.10	2.50	2.10	3.20	2.10	3.20	2.10	3.20
ØD	M 12 x 1-6g		M 15 x 1-6g		M 18 x 1-6g		M 22 x 1-6g		M 25 x 1-6g		M 28 x 1-6g		M 31 x 1-6g		M 34 x 1-6g		M 37 x 1-6g	
E	23.50	24.10	25.90	26.50	28.30	28.90	30.70	31.30	33.00	33.60	36.20	36.80	39.40	40.00	42.60	43.20	45.70	46.30
F	18.16	18.36	20.52	20.72	22.91	23.11	24.51	24.71	26.87	27.07	29.26	29.46	31.65	31.85	34.83	35.03	38.00	38.20
G	14.99	15.19	18.16	18.36	20.52	20.72	22.91	23.11	24.51	24.71	26.87	27.07	29.26	29.46	31.65	31.85	34.83	35.03
H	3.05	3.45	3.05	3.45	3.05	3.45	3.05	3.45	3.05	3.45	3.05	3.45	3.05	3.45	3.71	4.11	3.71	4.11
J	5.29	5.69	4.73	5.13	4.73	5.13	4.19	4.59	4.73	5.13	4.73	5.13	4.73	5.13	5.95	6.35	5.95	6.35
L	-	2.50	-	2.50	-	2.50	-	2.50	-	2.50	-	2.50	-	2.50	-	2.50	-	2.50
M #22(P)	11.64	12.94	11.64	12.94	11.64	12.94	11.64	12.94	11.64	12.94	11.64	12.94	11.64	12.94	12.46	13.76	12.46	13.76
M #22(S)	11.31	12.91	11.31	12.91	11.31	12.91	11.31	12.91	11.31	12.91	11.31	12.91	11.31	12.91	12.13	13.70	12.13	13.70
M #20(P)	11.81	13.11	11.81	13.11	11.81	13.11	11.81	13.11	11.81	13.11	11.81	13.11	11.81	13.11	12.63	13.93	12.63	13.93
M #20(S)	11.81	13.11	11.81	13.11	11.81	13.11	11.81	13.11	11.81	13.11	11.81	13.11	11.81	13.11	12.63	13.93	12.63	13.93
M #16(P)	11.81	13.11	11.81	13.11	11.81	13.11	11.81	13.11	11.81	13.11	11.81	13.11	11.81	13.11	12.63	13.93	12.63	13.93
M #16(S)	11.81	13.11	11.81	13.11	11.81	13.11	11.81	13.11	11.81	13.11	11.81	13.11	11.81	13.11	12.63	13.93	12.63	13.93
N #22(L)	8.30	8.50	8.30	8.50	8.30	8.50	8.30	8.50	8.30	8.50	8.30	8.50	8.30	8.50	8.30	8.50	8.30	8.50
N #22(C)	3.80	4.00	3.80	4.00	3.80	4.00	3.80	4.00	3.80	4.00	3.80	4.00	3.80	4.00	3.80	4.00	3.80	4.00
N #20(L)	8.30	8.50	8.30	8.50	8.30	8.50	8.30	8.50	8.30	8.50	8.30	8.50	8.30	8.50	8.30	8.50	8.30	8.50
N #20(C)	4.90	5.10	4.90	5.10	4.90	5.10	4.90	5.10	4.90	5.10	4.90	5.10	4.90	5.10	4.90	5.10	4.90	5.10
N #16(L)	8.30	8.50	8.30	8.50	8.30	8.50	8.30	8.50	8.30	8.50	8.30	8.50	8.30	8.50	8.30	8.50	8.30	8.50
N #16(C)	4.90	5.10	4.90	5.10	4.90	5.10	4.90	5.10	4.90	5.10	4.90	5.10	4.90	5.10	4.90	5.10	4.90	5.10
ØP #22	0.65	0.70	0.65	0.70	0.65	0.70	0.65	0.70	0.65	0.70	0.65	0.70	0.65	0.70	0.65	0.70	0.65	0.70
ØP #20	0.65	0.70	0.65	0.70	0.65	0.70	0.65	0.70	0.65	0.70	0.65	0.70	0.65	0.70	0.65	0.70	0.65	0.70
ØP #16	1.10	1.15	1.10	1.15	1.10	1.15	1.10	1.15	1.10	1.15	1.10	1.15	1.10	1.15	1.10	1.15	1.10	1.15

NOTES

1. All dimensions are in millimetres.



FIGURE 2 - PHYSICAL DIMENSIONS (CONTINUED)

FIGURE 2(a) - RECEPTACLES

Shell type 07: Single hole mounting receptacle

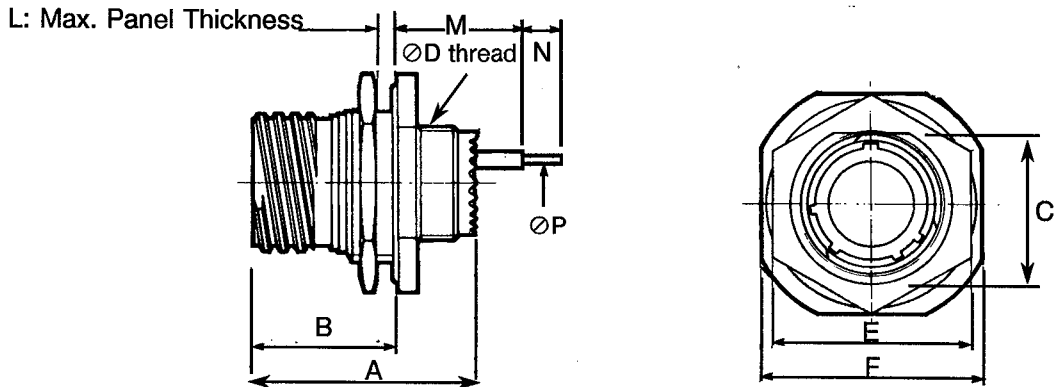

SHELL SIZE	09		11		13		15		17		19		21		23		25	
	MIN	MAX	MIN	MAX	MIN	MAX	MIN	MAX	MIN	MAX	MIN	MAX	MIN	MAX	MIN	MAX	MIN	MAX
A	-	32.50	-	32.50	-	32.50	-	32.50	-	32.50	-	32.50	-	32.50	-	32.50	-	32.50
B	-	22.60	-	22.60	-	22.60	-	22.60	-	22.60	-	22.60	-	22.60	-	22.60	-	22.60
C	16.38	16.63	18.92	19.17	23.67	23.92	26.82	27.07	30.00	30.25	33.17	33.42	36.35	36.60	39.52	39.77	42.70	42.95
ØD	M 12 x 1-6g		M 15 x 1-6g		M 18 x 1-6g		M 22 x 1-6g		M 25 x 1-6g		M 28 x 1-6g		M 31 x 1-6g		M 34 x 1-6g		M 37 x 1-6g	
E	-	24.00	-	27.00	-	32.00	-	36.00	-	37.00	-	41.00	-	46.00	-	50.00	-	51.23
F	26.60	27.40	31.40	32.20	34.50	35.30	37.70	38.50	40.90	41.70	45.60	46.40	48.80	49.60	52.00	52.80	55.20	56.00
L	-	3.20	-	3.20	-	3.20	-	3.20	-	3.20	-	3.20	-	3.20	-	3.20	-	3.20
M #22(P)	10.52	11.46	10.52	11.46	10.34	11.28	10.34	11.28	10.34	11.28	10.34	11.28	10.34	11.28	10.34	11.28	10.34	11.28
M #22(S)	10.19	11.46	10.19	11.46	10.01	11.28	10.01	11.28	10.01	11.28	10.01	11.28	10.01	11.28	10.01	11.28	10.01	11.28
M #20(P)	10.69	11.63	10.69	11.63	10.51	11.45	10.51	11.45	10.51	11.45	10.51	11.45	10.51	11.45	10.51	11.45	10.51	11.45
M #20(S)	10.69	11.63	10.69	11.63	10.51	11.45	10.51	11.45	10.51	11.45	10.51	11.45	10.51	11.45	10.51	11.45	10.51	11.45
M #16(P)	10.69	11.63	10.69	11.63	10.51	11.45	10.51	11.45	10.51	11.45	10.51	11.45	10.51	11.45	10.51	11.45	10.51	11.45
M #16(S)	10.69	11.63	10.69	11.63	10.51	11.45	10.51	11.45	10.51	11.45	10.51	11.45	10.51	11.45	10.51	11.45	10.51	11.45
N #22(L)	8.30	8.50	8.30	8.50	8.30	8.50	8.30	8.50	8.30	8.50	8.30	8.50	8.30	8.50	8.30	8.50	8.30	8.50
N #22(C)	3.80	4.00	3.80	4.00	3.80	4.00	3.80	4.00	3.80	4.00	3.80	4.00	3.80	4.00	3.80	4.00	3.80	4.00
N #20(L)	8.30	8.50	8.30	8.50	8.30	8.50	8.30	8.50	8.30	8.50	8.30	8.50	8.30	8.50	8.30	8.50	8.30	8.50
N #20(C)	4.90	5.10	4.90	5.10	4.90	5.10	4.90	5.10	4.90	5.10	4.90	5.10	4.90	5.10	4.90	5.10	4.90	5.10
N #16(L)	8.30	8.50	8.30	8.50	8.30	8.50	8.30	8.50	8.30	8.50	8.30	8.50	8.30	8.50	8.30	8.50	8.30	8.50
N #16(C)	4.90	5.10	4.90	5.10	4.90	5.10	4.90	5.10	4.90	5.10	4.90	5.10	4.90	5.10	4.90	5.10	4.90	5.10
ØP #22	0.65	0.70	0.65	0.70	0.65	0.70	0.65	0.70	0.65	0.70	0.65	0.70	0.65	0.70	0.65	0.70	0.65	0.70
ØP #20	0.65	0.70	0.65	0.70	0.65	0.70	0.65	0.70	0.65	0.70	0.65	0.70	0.65	0.70	0.65	0.70	0.65	0.70
ØP #16	1.10	1.15	1.10	1.15	1.10	1.15	1.10	1.15	1.10	1.15	1.10	1.15	1.10	1.15	1.10	1.15	1.10	1.15

NOTES

1. All dimensions are in millimetres.



FIGURE 2 - PHYSICAL DIMENSIONS (CONTINUED)

FIGURE 2(b) - HIGH DENSITY CONTACT ARRANGEMENTS - FRONT VIEW MALE INSERT

09-35



6 # 22D

11-35



13 # 22D

13-35

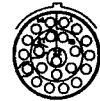

22 # 22D

15-35

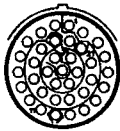

37 # 22D

17-35

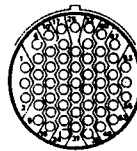

55 # 22D

19-35

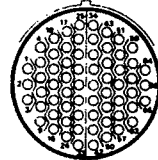

66 # 22D

21-35

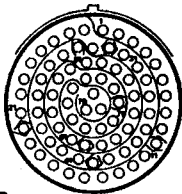

79 # 22D

23-35

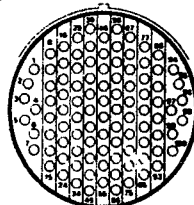

100 # 22D

25-35

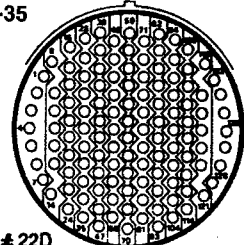

128 # 22D

NOTES

1. Contact locations and identifications in conformity with MIL-STD-1560.
2. Both sides of the inserts shall be marked.

FIGURE 2 - PHYSICAL DIMENSIONS (CONTINUED)

FIGURE 2(b) - STANDARD CONTACT ARRANGEMENTS - FRONT VIEW MALE INSERT

09-98

3 # 20



11-98

6 # 20



13-98

10 # 20



15-19

19 # 20

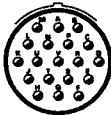

17-26

26 # 20

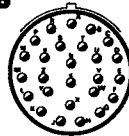

19-32

32 # 20

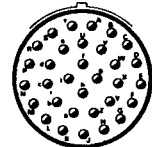

21-41

41 # 20

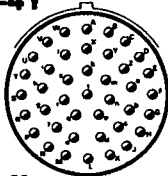

23-53

53 # 20

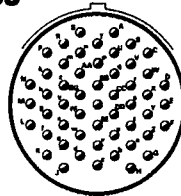

25-61

61 # 20

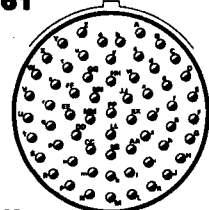

NOTES

1. Contact locations and identifications in conformity with MIL-STD-1560.
2. Both sides of the inserts shall be marked.



FIGURE 2 - PHYSICAL DIMENSIONS (CONTINUED)

FIGURE 2(b) - SPECIAL CONTACT ARRANGEMENTS - FRONT VIEW MALE INSERT

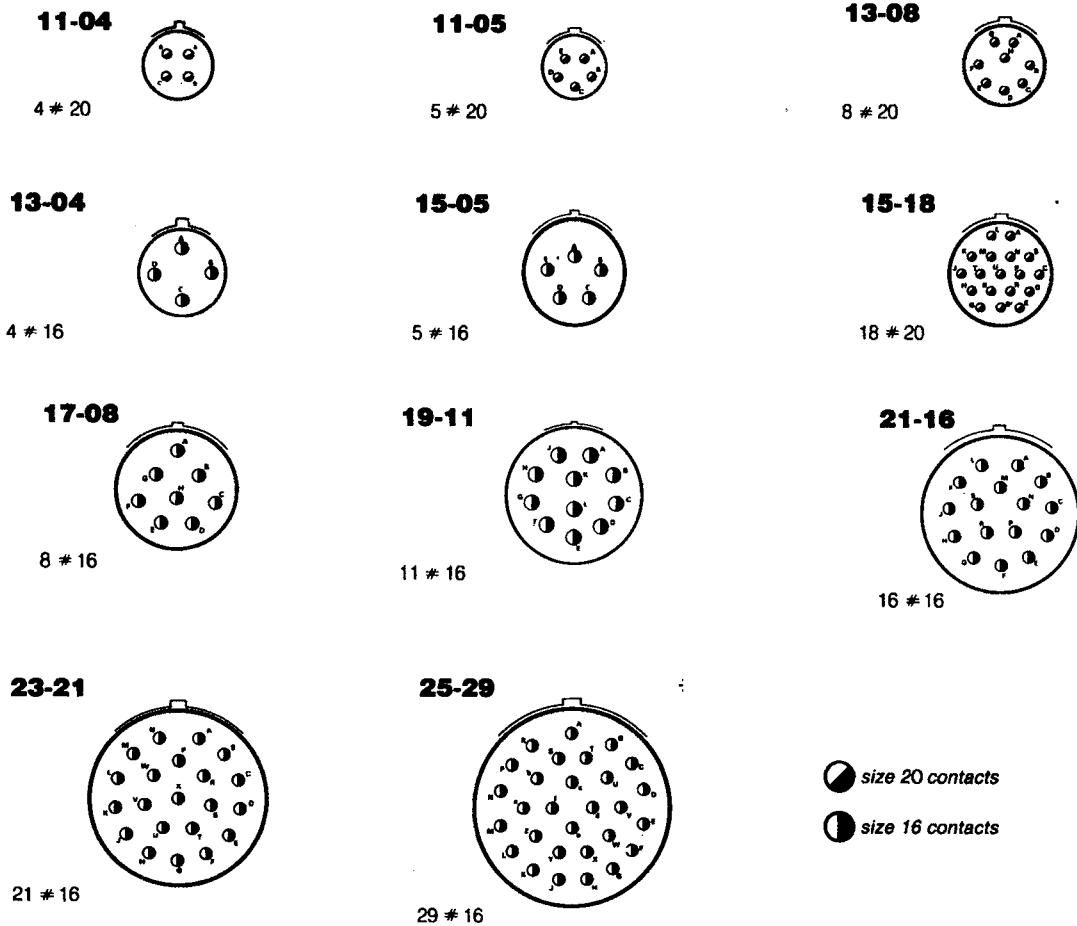

NOTES

1. Contact locations and identifications in conformity with MIL-STD-1560.
2. Both sides of the inserts shall be marked.



FIGURE 2- PHYSICAL DIMENSIONS (CONTINUED)

FIGURE 2(c) - CLOCKING POSITIONS

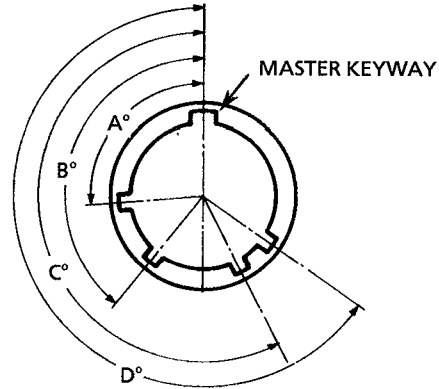

NOTES

1. The clocking position is determined by the different angles of the secondary keyways, the insert being always in the same position with respect to the master keyway position which is fixed.

Receptacle front end view

SHELL SIZE	ANGLES	CLOCKING POSITIONS					
		N	A	B	C	D	E
09	A°	105	102	80	35	64	91
	B°	140	132	118	140	155	131
	C°	215	248	230	205	234	197
	D°	265	320	312	275	304	240
11	A°	95	113	90	53	119	51
	B°	141	156	145	156	146	141
	C°	208	182	195	220	176	184
	D°	236	292	252	255	298	242
13	A°	95	113	90	53	119	51
	B°	141	156	145	156	146	141
	C°	208	182	195	220	176	184
	D°	236	292	252	255	298	242
15	A°	95	113	90	53	119	51
	B°	141	156	145	156	146	141
	C°	208	182	195	220	176	184
	D°	236	292	252	255	298	242
17	A°	80	135	49	66	62	79
	B°	142	170	169	140	145	153
	C°	196	200	200	200	180	197
	D°	293	310	244	257	280	272
19	A°	80	135	49	66	62	79
	B°	142	170	169	140	145	153
	C°	196	200	200	200	180	197
	D°	293	310	244	257	280	272
21	A°	80	135	49	66	62	79
	B°	142	170	169	140	145	153
	C°	196	200	200	200	180	197
	D°	293	310	244	257	280	272
23	A°	80	135	49	66	62	79
	B°	142	170	169	140	145	153
	C°	196	200	200	200	180	197
	D°	293	310	244	257	280	272
25	A°	80	135	49	66	62	79
	B°	142	170	169	140	145	153
	C°	196	200	200	200	180	197
	D°	293	310	244	257	280	272

**4. REQUIREMENTS****4.1 GENERAL**

The complete requirements for procurement of the connectors specified herein are stated in this specification and ESA/SCC Generic Specification No. 3401. Deviations from the Generic Specification applicable to this specification only, are listed in Para 4.2.

Deviations from the applicable Generic Specification and this Detail Specification, formally agreed with specific Manufacturers on the basis that the alternative requirements are equivalent to the ESA/SCC requirements and do not affect the components' reliability, are listed in the Appendices attached to this specification.

4.2 DEVIATIONS FROM GENERIC SPECIFICATION**4.2.1 Deviations from Special In-process Controls**

None.

4.2.2 Deviations from Final Production Tests (Chart II)

(a) Para 9.5, Magnetism Level: Not applicable. Instead, a magnetic permeability test shall be performed in accordance with Method 3006 of MIL-STD-1344. The magnetic permeability of assembled connectors (with contacts and accessories as applicable) shall not exceed 2Mu. The test shall be performed on 1 sample per shell size.

4.2.3 Deviations from Burn-in and Electrical Measurements (Chart III)

Not applicable.

4.2.4 Deviations from Qualification Tests (Chart IV)

(a) Para. 9.10, Wiring: The connectors shall be mounted on an appropriate P.C.B.

(b) Para. 9.11.2, Sinusoidal Vibration Testing:

- 10-55Hz at 8.25mm double amplitude displacement.
- 56-2000Hz at 50g.
- 1 cycle (10-2000-10 Hz) per axis at a sweep rate of 1 octave per minute.

(c) Para. 9.11.3, Random Vibration Testing:

- 20-100Hz at +6dB per octave.
- 100-2000Hz, constant at 1.0g²/Hz.
- 3 axes.
- 7 minutes per axis.

(d) Para. 9.12.1, Shock: 75g, 11 milliseconds, half sine wave.

(e) Para. 9.15, Joint Strength: Not applicable.

(f) Para. 9.24, Jackscrew Retention: Not applicable.

(g) Para. 9.27, Maintenance Ageing: Not applicable.

4.2.5 Deviations from Lot Acceptance Tests (Chart V)

(a) Para. 9.10, Wiring: The connectors shall be mounted on an appropriate P.C.B.

(b) Para. 9.15, Joint Strength: Not applicable.



4.3 MECHANICAL REQUIREMENTS

4.3.1 Dimension Check

The dimensions of the connectors specified herein shall be verified in accordance with the requirements set out in Para 9.6 of ESA/SCC Generic Specification No. 3401 and shall conform to those shown in Figure 2 of this specification.

4.3.2 Weight

The maximum weight of the connectors and contacts specified herein, shall be as specified in Table 1(a).

4.3.3 Contact Capability

As specified in ESA/SCC Detail Specification No. 3401/058.

4.3.4 Contact Retention (In Insert)

As specified in ESA/SCC Detail Specification No. 3401/058.

4.3.5 Mating and Unmating Forces

Mating and unmating shall be performed with a plug as specified in ESA/SCC Detail Specification No. 3401/056 and the forces shall meet the requirements of Table 1(a) of that specification.

4.3.6 Insert Retention (In Shell)

Connector inserts shall withstand a pressure of 53.7N/cm² without being dislodged from the shell.

4.3.7 Jackscrew Retention

Not applicable.

4.3.8 Contact Insertion and Withdrawal Forces

Not applicable.

4.3.9 Engagement and Separation Forces

As specified in ESA/SCC Detail Specification No. 3401/058.

4.3.10 Oversize Pin Exclusion

As specified in ESA/SCC Detail Specification No. 3401/058.

4.3.11 Probe Damage

As specified in ESA/SCC Detail Specification No. 3401/058.

4.3.12 Solderability

Size A soldering iron shall be used.

4.4 MATERIALS AND FINISHES

The materials and finishes shall be as specified herein. Where a definite material is not specified, a material which will enable the connectors specified herein to meet the performance requirements of this specification shall be used. Acceptance or approval of any constituent material does not guarantee acceptance of the finished product.

4.4.1 Shell and Nuts

The shell and nuts shall be made of aluminium alloy, dull low reflective electroless nickel plated.

4.4.2 Inserts

Bonded sandwich, silicone/thermosetting or thermoplastic insert/silicone.



4.4.3 Contacts

As specified in the ESA/SCC Detail Specification No. 3401/058.

4.4.4 Contact Retaining Clip

The retaining clip shall be made of beryllium copper.

4.4.5 Guiding and Locking Devices

Not applicable.

4.4.6 Magnetism Level

Not applicable.

4.5 MARKING

4.5.1 General

The marking of all components delivered to this specification shall be in accordance with with the requirements of ESA/SCC Basic Specification No. 21700 and the following paragraphs. When the component is too small to accommodate all of the marking specified, as much as space permits shall be marked and the marking information, in full, shall accompany the component in its primary package.

The information to be marked and the order of precedence, shall be as follows:

- (a) Contact Identification.
- (b) The SCC Component Number.
- (c) Characteristics.
- (d) Traceability information.

4.5.2 Contact Identification

Contact identification shall be marked on the inserts in accordance with Figure 2(b).

4.5.3 The SCC Component Number

The SCC component number shall be constituted and marked as follows:

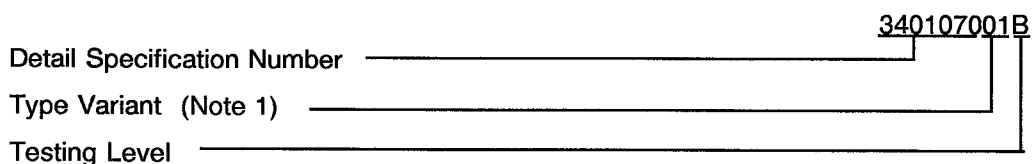

NOTES

1. Marking of the Type Variant is mandatory. No further reference to type variants is made in this specification.



4.5.4 Characteristics

The characteristics to be marked in the following order of precedence are:-

- (a) Shell type.
- (b) Contact Post Type.
- (c) Contact arrangement.
- (d) Type of contact.
- (e) Clocking position.

The information shall be constituted and marked as follows:-

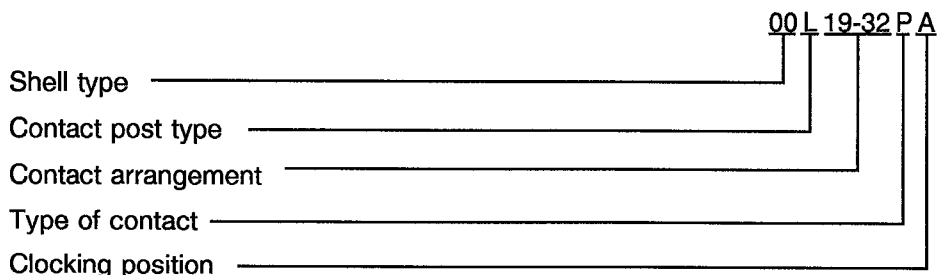

4.5.4.1 Shell Type

The shell type shall be indicated by the numbers specified hereafter.

CODE NO	SHELL TYPE
00	Square flange receptacle
07	Single hole mounting receptacle

4.5.4.2 Contact Post Type

The contact post type shall be indicated by the following letters:

- L : Long
- C : Short.

4.5.4.3 Contact Arrangements

The number of contacts shall be as shown in Figure 2(b) and contact arrangements shall be indicated by the codes specified hereafter.

Service rating is applicable to connectors not mounted on a P.C.B.

CODE	SERVICE RATING
09-35	M
09-98	I
11-35	M
11-98	I
11-05	I
11-04	I
13-35	M
13-98	I
13-08	I
13-04	II
15-35	M
15-19	I
15-05	II
15-18	I
17-35	M
17-26	I
17-06	I
17-28	I

CODE	SERVICE RATING
19-35	M
19-32	I
19-11	II
21-35	M
21-41	I
21-16	II
23-35	M
23-53	I
23-21	II
25-35	M
25-61	I
25-19	I
25-29	I

4.5.4.4 Type of Contact

The contact type shall be indicated by the following code letters.

CODE LETTER	CONTACT TYPE
P	Male
S	Female

4.5.4.5 Clocking Position

Clocking positions are as shown in Figure 2(c) and shall be designated by the following code letters: A, B, C, D and E. Code letter N indicates the standard clocking position.

4.5.5 Traceability Information

Traceability information shall be marked in accordance with the requirements of ESA/SCC Basic Specification No. 21700.

4.6 ELECTRICAL MEASUREMENTS

4.6.1 Electrical Measurements at Room Temperature

The parameters to be measured in respect of electrical characteristics are scheduled in Table 2. Unless otherwise specified these measurements shall be performed at $T_{amb} = +22 \pm 3 \text{ }^\circ\text{C}$.

4.6.2 Electrical Measurements at High and Low Temperatures (Table 3)

Not applicable.

4.6.3 Circuit for Electrical Measurements (Figure 4)

Not applicable.

4.7 BURN-IN AND ELECTRICAL MEASUREMENTS (TABLES 4 AND 5)

Not applicable.



TABLE 2 - ELECTRICAL MEASUREMENTS AT ROOM TEMPERATURE

NO	CHARACTERISTICS	SYMBOL	SPEC. AND/OR TEST METHOD	TEST CONDITION	LIMITS		UNIT
					MIN	MAX	
1	Insulation Resistance	Ri	ESA/SCC No. 3401 Para 9.1.1.1	Para 9.1.1.1	10 000	-	MΩ
2	Voltage Proof Leakage Current (2) Service II Service I Service M	I _L	ESA/SCC No. 3401 Para 9.1.1.2	2300Vrms 1800Vrms 1300Vrms	- - -	2.0 2.0 2.0	mA mA mA
3	Mated Shell Conductivity (1) (Voltage Drop)	Vd	ESA/SCC No. 3401 Para. 9.1.1.4	Para. 9.1.1.4	-	1.0	mV
4	Contact Resistance (Low Level Current)	R _{cl}	ESA/SCC No. 3401 Para. 9.1.1.3	Para. 9.1.1.3	-	8.0	mΩ
5	Contact Resistance (Rated Current) Contact Size 22 Contact Size 20 Contact Size 16	R _{cr}	ESA/SCC No. 3401 Para. 9.1.1.3	Para. 9.1.1.3 3.0A 5.0A 10A	- - -	14 7.0 4.0	mΩ mΩ mΩ

NOTES

1. Applicable to mated connectors with grounding option.
2. Service rating values are only applicable to connectors not mounted on a P.C.B.

TABLES 3, 4 AND 5

Not applicable.



- 4.8 ENVIRONMENTAL AND ENDURANCE TESTS (CHARTS IV AND V OF ESA/SCC GENERIC SPECIFICATION NO. 3401)
- 4.8.1 Measurements and Inspections on Completion of Environmental Tests
The parameters to be measured and inspections to be performed on completion of environmental testing shall be those specified in Table 6. Unless otherwise specified, these measurements shall be performed at $T_{amb} = +22 \pm 3 \text{ }^\circ\text{C}$.
- 4.8.2 Measurements and Inspections at Intermediate Points during Endurance Tests.
Not applicable.
- 4.8.3 Measurements and Inspections on Completion of Endurance Tests
The parameters to be measured and inspections to be performed on completion of endurance tests shall be those specified in Table 6. Unless otherwise specified, these measurements shall be performed at $T_{amb} = +22 \pm 3 \text{ }^\circ\text{C}$.
- 4.8.4 Conditions for Operating Life Test (Part of Endurance Testing)
Not applicable.
- 4.8.5 Electrical Circuits for Operating Life Test
Not applicable.
- 4.8.6 Conditions for High Temperature Storage Test (Part of Endurance Testing)
The requirements for the high temperature storage test are specified in Section 9 of ESA/SCC Generic Specification No. 3401. The conditions for high temperature storage testing shall be the maximum temperature specified in Table 1(b) of this specification.



TABLE 6 - MEASUREMENTS AND INSPECTIONS ON COMPLETION OF ENVIRONMENTAL AND ENDURANCE TESTS (CONTINUED)

NO.	ESA/SCC GENERIC NO. 3401		MEASUREMENTS AND INSPECTIONS		SYMBOL	LIMITS		UNIT
	ENVIRONMENTAL AND ENDURANCE TESTS (1)	TEST METHOD AND CONDITIONS	IDENTIFICATION	CONDITIONS		MIN	MAX	
11	Permanence of Marking	Para. 9.19	As applicable		-	-	-	
12	Mating/Unmating Forces	Para. 9.20	Force		F	Para. 4.3.5 of this spec.		
13	High Temperature Storage	Para. 9.21	Initial Measurements Low Level Contact Resis. Mated Shell Conductivity Final Measurements Visual Examination Mating/Unmating Forces Low Level Contact Resistance Drift Rated Current Contact Resis. Mated Shell Conductivity Insulation Resistance Voltage Proof Leakage Curr. Contact Retention (In insert)	Table 2 Item 4 Table 2 Item 3 - Table 2 Item 4 Table 2 Item 5 Table 2 Item 3 Table 2 Item 1 Table 2 Item 2 Para. 4.3.4 of this spec.	Rcl Vd - F ΔRcl Rcr Vd Ri I _L	Record Values Table 2 Item 3 - - Para. 4.3.5 of this spec. - 3.0 Table 2 Item 5 Table 2 Item 3 Table 2 Item 1 Table 2 Item 2 ESA/SCC 3401 Para. 9.17	mΩ	
14	Corrosion	Para. 9.22	Visual Examination	-	-	-	-	
15	Insert Retention (In shell)	Para. 9.23 & Para. 4.3.6 of this spec.	Visual Examination	-	-	Para. 4.3.6		
16	Jackscrew Retention	Para. 9.24 & Para. 4.3.7 of this spec.	Visual Examination	-	-	Not applicable		
17	High Temperature Measurements	Para. 9.25	Insulation Resistance	Table 2 Item 1	Ri	500	-	MΩ
18	Overload Test	Para. 9.26	Internal Temperature Rated Current Contact Resis. Mated Shell Conductivity Insulation Resistance Voltage Proof Leakage Curr.	Table 2 Item 5 Table 2 Item 3 Table 2 Item 1 Table 2 Item 2	T Rcr Vd Ri I _L	-	+100	°C
19	Maintenance Aging	Para. 9.27	Not applicable					
20	Engage/Separation Forces	Para. 9.28 & Para. 4.3.9 of this spec.	Force		F			

NOTES

1. The tests in this table refer to either Chart IV or V and shall be used as applicable.



TABLE 6 - MEASUREMENTS AND INSPECTIONS ON COMPLETION OF ENVIRONMENTAL AND ENDURANCE TESTS (CONTINUED)

NO.	ESA/SCC GENERIC NO. 3401		MEASUREMENTS AND INSPECTIONS		SYMBOL	LIMITS		UNIT
	ENVIRONMENTAL AND ENDURANCE TESTS (1)	TEST METHOD AND CONDITIONS	IDENTIFICATION	CONDITIONS		MIN	MAX	
21	Oversize Pin Exclusion	Para. 9.29 & Para. 4.3.10 of this spec.				ESA/SCC 3401 Para. 9.29		
22	Probe Damage	Para. 9.30 & Para. 4.3.11 of this spec.	Contact Separation Force	Para. 4.3.9 of this spec.	F	Para. 4.3.9		
23	Solderability	Para. 9.31 & Para. 4.3.12 of this spec.				Para. 4.3.12		

NOTES

1. The tests in this table refer to either Chart IV or V and shall be used as applicable.