



europaean space agency  
agence spatiale européenne

Pages 1 to 22

**RELAYS, ELECTROMAGNETIC, NON-LATCHING**

**28Vdc, 15A, 2PDT**

**ESA/SCC Detail Specification No. 3601/007**



**space components  
coordination group**

Issue/Rev.	Date	Approved by	
		SCCG Chairman	ESA Director General or his Deputy
Issue 3	December 2000	<i>Sam Malt</i>	<i>[Signature]</i>
Revision 'A'	February 2002	<i>[Signature]</i>	<i>[Signature]</i>



**DOCUMENTATION CHANGE NOTICE**

Rev. Letter	Rev. Date	Reference	CHANGE Item	Approved DCR No.
		<p>This Issue supersedes Issue 2 and incorporates all modifications defined in Revisions 'A', 'B' and 'C' to Issue 2 and the following DCRs:-</p> <p>Cover page : In the Title, "26.5" amended to "28" and : "AMP" amended to "A"</p> <p>DCN Para. 1.1 : In the first sentence, "26.5" amended to "28" and : "AMP" amended to "A"</p> <p>Table 1(b) : No. 2, completely amended to "Coil Voltage Range"</p> <p>Table 2 : No. 2, Limits amended</p>		<p>221592 221599 None 221592 221599 221599 221592</p>
'A'	Feb. '02	<p>P1. Cover page P2. DCN P17. Table 2.</p>	<p>: No. 1, New Max. values inserted for "Pick-up Voltage". : No. 2, New Min. and Max. values inserted for "Drop-out Voltage".</p> <p>P18. Table 3. : No. 2, New Min. and Max. values inserted for "Drop-out Voltage".</p>	<p>None None 221618 221618 221618</p>

**TABLE OF CONTENTS**

	<u>Page</u>
<b>1. <u>GENERAL</u></b>	<b>5</b>
1.1 Scope	5
1.2 Component Type Variants	5
1.3 Maximum Ratings	5
1.4 Parameter Derating Information	5
1.5 Physical Dimensions	5
1.6 Circuit Schematic	5
<b>2. <u>APPLICABLE DOCUMENTS</u></b>	<b>5</b>
<b>3. <u>TERMS, DEFINITIONS, ABBREVIATIONS, SYMBOLS AND UNITS</u></b>	<b>5</b>
<b>4. <u>REQUIREMENTS</u></b>	<b>14</b>
4.1 General	14
4.2 Deviations from Generic Specification	14
4.2.1 Deviations from Special In-process Controls	14
4.2.2 Deviations from Final Production Tests	14
4.2.3 Deviations from Screening Tests	14
4.2.4 Deviations from Qualification Tests	14
4.2.5 Deviations from Lot Acceptance Tests	14
4.3 Mechanical Requirements	15
4.3.1 Dimension Check	15
4.3.2 Weight	15
4.3.3 Terminal Strength	15
4.4 Materials and Finishes	15
4.4.1 Case	15
4.4.2 Terminal Material and Finish	15
4.5 Marking	15
4.5.1 General	15
4.5.2 Terminal Identification	15
4.5.3 The SCC Component Number	16
4.5.4 Electrical Characteristics	16
4.5.5 Traceability Information	16
4.6 Electrical Measurements	16
4.6.1 Electrical Measurements at Room Temperature	16
4.6.2 Electrical Measurements at High and Low Temperatures	16
4.6.3 Circuits for Electrical Measurements	16
4.7 Screening	16
4.7.1 Miss Test	16
4.7.2 Conditions for Screening	16
4.7.3 Electrical Circuits for Screening	16
4.8 Environmental and Endurance Tests	20
4.8.1 Measurements and Inspections on Completion of Environmental Tests	20
4.8.2 Measurements and Inspections during Endurance Tests	20
4.8.3 Measurements and Inspections on Completion of Endurance Tests	20
4.8.4 Conditions for Operating Life Tests	20
4.8.5 Electrical Circuits for Operating Life Tests	20

**SCC**ESA/SCC Detail Specification  
No. 3601/007PAGE 4  
ISSUE 3**TABLES**

	<u>Page</u>
1(a) Type Variants	6
1(b) Maximum Ratings	6
2 Electrical Measurements at Room Temperature	17
3 Electrical Measurements at High and Low Temperatures	18
4 Measurements during Screening	19
5(a) Conditions for Screening	19
5(b) Conditions for Operating Life Test	19
6 Measurements and Inspections on Completion of Environmental Tests and at Intermediate Points and on Completion of Endurance Testing	21

**FIGURES**

1 Not applicable	N/A
2 Physical Dimensions	7
3 Circuit Schematic	13
4 Circuits for Electrical Measurements	N/A
5(a) Electrical Circuits for Screening	N/A
5(b) Electrical Circuits for Operating Life Tests	N/A

**APPENDICES (Applicable to specific Manufacturers only)**

None.

**1. GENERAL****1.1 SCOPE**

This specification details the ratings, physical and electrical characteristics, test and inspection data for a Relay, Electromagnetic, Non-Latching, 28Vdc, 15A, 2PDT. It shall be read in conjunction with ESA/SCC Generic Specification No. 3601, the requirements of which are supplemented herein.

**1.2 COMPONENT TYPE VARIANTS**

Variants of the basic type relays specified herein, which are also covered by this specification, are given in Table 1(a).

**1.3 MAXIMUM RATINGS**

The maximum ratings, which shall not be exceeded at any time during use or storage, applicable to the relays specified herein, are as scheduled in Table 1(b).

**1.4 PARAMETER DERATING INFORMATION (FIGURE 1)**

Not applicable.

**1.5 PHYSICAL DIMENSIONS**

The physical dimensions of the relays specified herein are shown in Figure 2.

**1.6 CIRCUIT SCHEMATIC**

The circuit schematic, showing lead identification etc. for the relays specified herein, is shown in Figure 3.

**2. APPLICABLE DOCUMENTS**

The following documents form part of this specification and shall be read in conjunction with it:-

- (a) ESA/SCC Generic Specification No. 3601 for Relays, Electromagnetic, Non-Latching.
- (b) MIL-STD-202, Test Methods for Electronic and Electrical Component Parts.

**3. TERMS, DEFINITIONS, ABBREVIATIONS, SYMBOLS AND UNITS**

For the purpose of this specification, the terms, definitions, abbreviations, symbols and units specified in ESA/SCC Basic Specification No. 21300 shall apply.

**TABLE 1(a) - TYPE VARIANTS**

VARIANT	DESCRIPTION	FIGURE
01	Relay with Plug-in Terminals and Plain Case	2(a)
02	Relay with Solderable Hook-end Terminals and Plain Case	2(b)
03	Relay with Plug-in Terminals and Horizontal Flange Mount	2(c)
04	Relay with Solderable Hook-end Terminals and Horizontal Flange Mount	2(d)
05	Relay with Plug-in Terminals and Vertical Flange Mount	2(e)
06	Relay with Solderable Hook-end Terminals and Vertical Flange Mount	2(f)

**TABLE 1(b) - MAXIMUM RATINGS**

No.	CHARACTERISTICS	SYMBOL	MAXIMUM RATING	UNIT	REMARKS
1	Rated Coil Voltage:- 28V 12V 6V	$V_C$	28 12 6.0	Vdc	
2	Coil Voltage Range :- 28V 12V 6V	$V_{CR}$	26.5 to 32 11 to 14.8 5.5 to 7.3	Vdc	
3	Rated Contact Current Resistive Load	$I_{CR}$	15	A	28Vdc resistive Note 1
4	Overload Current Resistive	$I_{overl}$	40	A	28Vdc resistive See Table 6
5	Rated Contact Current Inductive Load	$I_{CL}$	10	A	28Vdc inductive Note 1
6	Contact Resistance	$R_C$	10	m $\Omega$	
7	High Temperature	$T_{amb}$	+ 125	$^{\circ}C$	
8	Low Temperature	$T_{amb}$	- 65	$^{\circ}C$	
9	Soldering Temperature	$T_{sol}$	+ 260	$^{\circ}C$	Note 2

**NOTES**

1. Relays should not be used in change-over mode where the potential difference between stationary contacts is greater than 10V and the switched current is greater than 0.1A.
2. Duration 10 seconds maximum at a distance of not less than 3.0mm from the device body and the same terminal shall not be resoldered until 3 minutes have elapsed.



**FIGURE 2 - PHYSICAL DIMENSIONS**

**FIGURE 2(a) - VARIANT 01, RELAY WITH PLUG-IN TERMINALS AND PLAIN CASE**

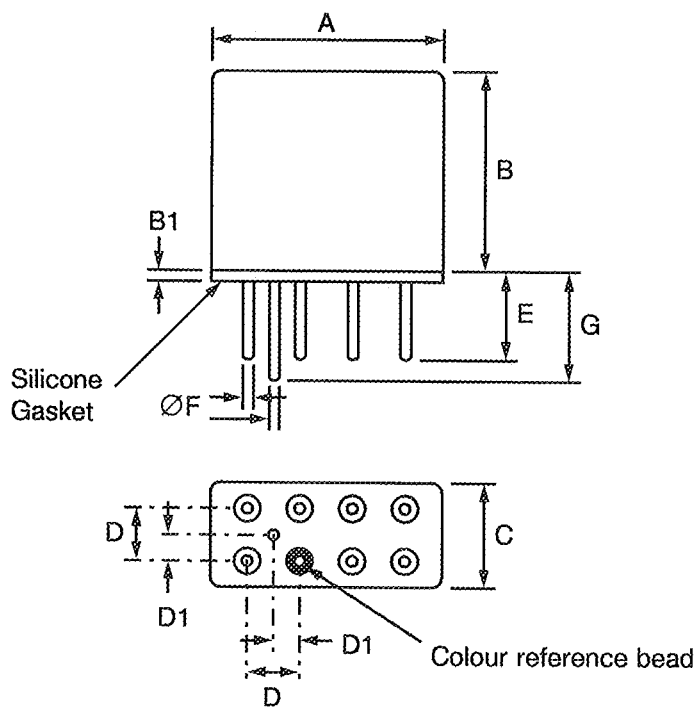

SYMBOL	MILLIMETRES	
	MIN.	MAX.
A	-	25.80
B	-	25.70
B1	1.20	1.40
C	-	13.00
D	4.98	5.18
D1	2.49	2.59
E	6.80	7.00
ØF	1.55	1.59
G	7.80	8.00



**FIGURE 2 - PHYSICAL DIMENSIONS (CONTINUED)**

**FIGURE 2(b) - VARIANT 02, RELAY WITH SOLDERABLE HOOK-END TERMINALS AND PLAIN CASE**

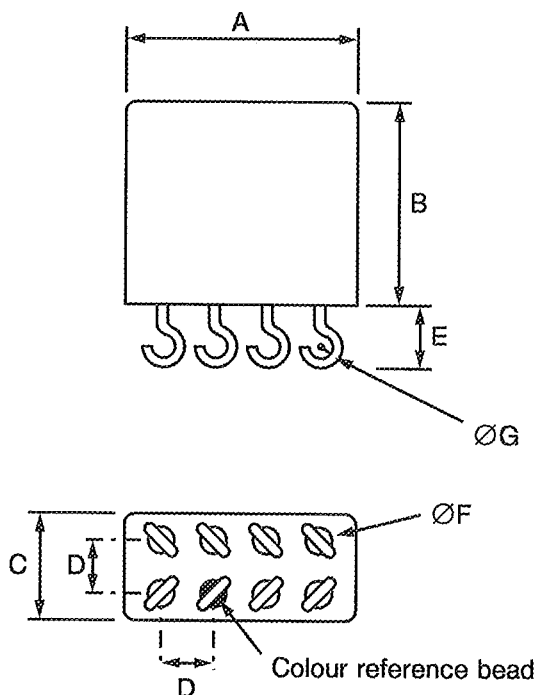

SYMBOL	MILLIMETRES	
	MIN.	MAX.
A	-	25.80
B	-	25.70
C	-	13.00
D	4.80	5.20
E	7.80	8.00
ØF	1.55	1.59
ØG	1.90	2.10





**FIGURE 2 - PHYSICAL DIMENSIONS (CONTINUED)**

**FIGURE 2(c) - VARIANT 03, RELAY WITH PLUG-IN TERMINALS AND HORIZONTAL FLANGE MOUNT**

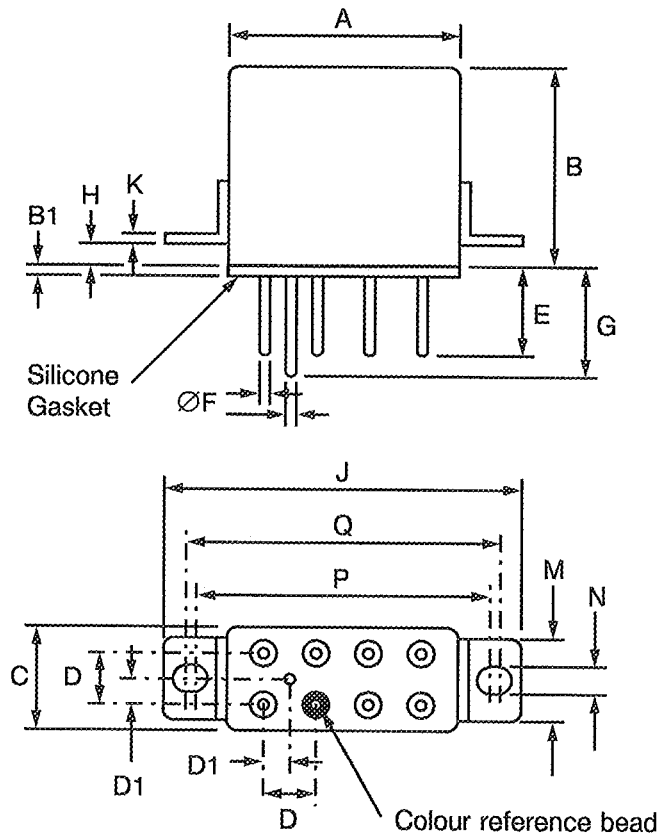

SYMBOL	MILLIMETRES	
	MIN.	MAX.
A	-	25.80
B	-	25.70
B1	1.20	1.40
C	-	13.00
D	4.98	5.18
D1	2.49	2.59
E	6.80	7.00
ØF	1.55	1.59
G	7.80	8.00
H	3.90	4.10
J	-	43.60
K	0.90	1.10
M	-	11.60
N	3.70	3.90
P	35.40	35.60
Q	36.60	36.80



**FIGURE 2 - PHYSICAL DIMENSIONS (CONTINUED)**

**FIGURE 2(d) - VARIANT 04, RELAY WITH SOLDERABLE HOOK-END TERMINALS AND HORIZONTAL FLANGE MOUNT**

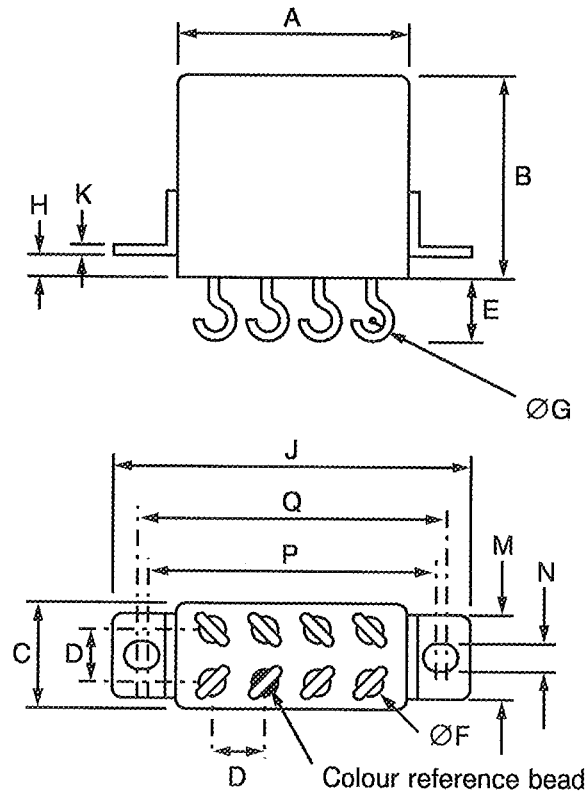

SYMBOL	MILLIMETRES	
	MIN.	MAX.
A	-	25.80
B	-	25.70
C	-	13.00
D	4.80	5.20
E	7.80	8.00
ØF	1.55	1.59
ØG	1.90	2.10
H	3.90	4.10
J	-	43.60
K	0.90	1.10
M	-	11.60
N	3.70	3.90
P	35.40	35.60
Q	36.60	36.80



**FIGURE 2 - PHYSICAL DIMENSIONS (CONTINUED)**

**FIGURE 2(e) - VARIANT 05, RELAY WITH PLUG-IN TERMINALS AND VERTICAL FLANGE MOUNT**

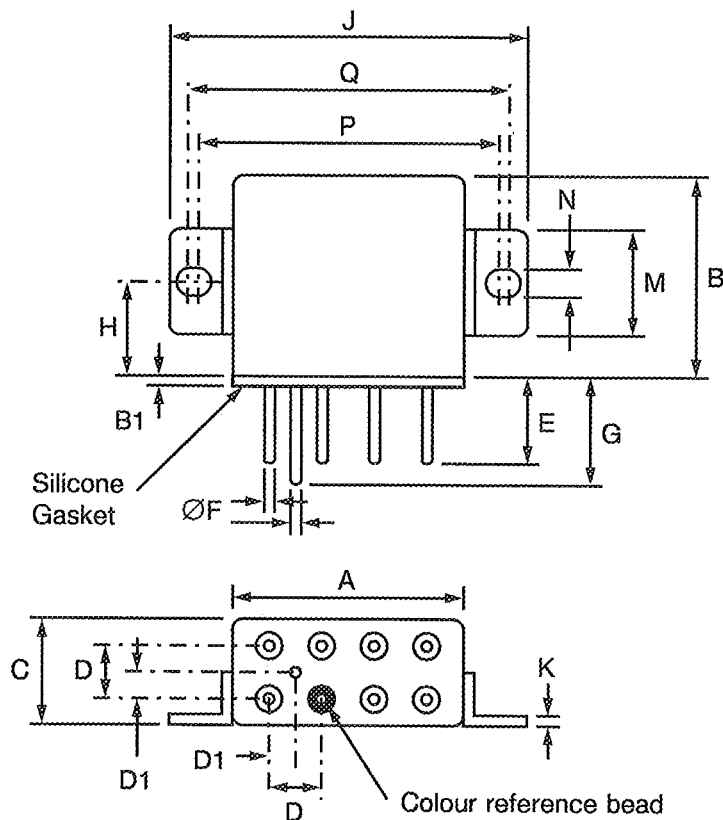

SYMBOL	MILLIMETRES	
	MIN.	MAX.
A	-	25.80
B	-	25.70
B1	1.20	1.40
C	-	13.00
D	4.98	5.18
D1	2.49	2.59
E	6.80	7.00
ØF	1.55	1.59
G	7.80	8.00
H	12.60	12.80
J	-	43.60
K	0.90	1.10
M	-	11.80
N	3.70	3.90
P	36.60	36.80
Q	35.40	35.60



**FIGURE 2 - PHYSICAL DIMENSIONS (CONTINUED)**

**FIGURE 2(f) - VARIANT 06, RELAY WITH SOLDERABLE HOOK-END TERMINALS AND VERTICAL FLANGE MOUNT**

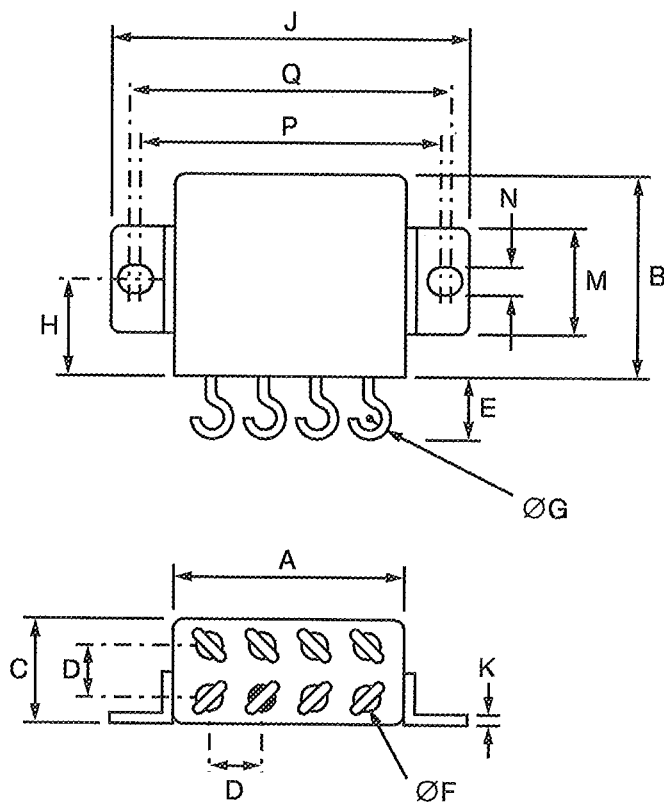

SYMBOL	MILLIMETRES	
	MIN.	MAX.
A	-	25.80
B	-	25.70
C	-	13.00
D	4.80	5.20
E	7.80	8.00
ØF	1.55	1.59
ØG	1.90	2.10
H	12.60	12.80
J	-	43.60
K	0.90	1.10
M	-	11.80
N	3.70	3.90
P	36.60	36.80
Q	35.40	35.60



**FIGURE 3 - CIRCUIT SCHEMATIC**

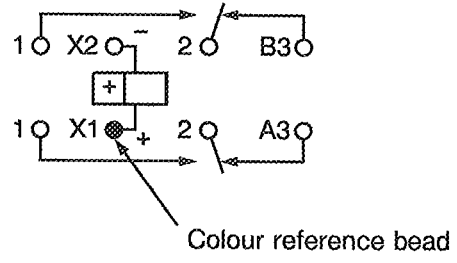



#### 4. REQUIREMENTS

##### 4.1 GENERAL

The complete requirements for procurement of the relays specified herein shall be as stated in this specification and ESA/SCC Generic Specification No. 3601 for Relays, Electromagnetic Non-Latching. Deviations from the Generic Specification, applicable to this specification only, are listed in Para. 4.2.

Deviations from the applicable Generic Specifications and this Detail Specification, formally agreed with specific Manufacturers on the basis that the alternative requirements are equivalent to the ESA/SCC requirements and do not affect the components' reliability, are listed in the appendices attached to this specification.

##### 4.2 DEVIATIONS FROM GENERIC SPECIFICATION

###### 4.2.1 Deviations from Special In-process Controls

None.

###### 4.2.2 Deviations from Final Production Tests (Chart II)

None.

###### 4.2.3 Deviations from Screening Tests (Chart III)

(a) Para. 9.6, Vibration Scan: Frequency Range: 10 - 3000 Hz.

###### 4.2.4 Deviations from Qualification Tests (Chart IV)

(a) Para. 9.10, Vibration: Frequency Range: 10 - 3000 Hz.

(b) Para. 9.11, Mechanical Shock: Test Condition: 200g, 6.0ms, 1/2 sinewave.

(c) Para. 9.12, Overload: Separate tests shall be performed for N/O and N/C contacts.

###### 4.2.5 Deviations from Lot Acceptance Tests (Chart V)

(a) Para. 9.10, Vibration: Frequency Range: 10 - 3000 Hz.

(b) Para. 9.11, Mechanical Shock: Test Condition: 200g, 6.0ms, 1/2 sinewave.

(c) Para. 9.12, Overload: Separate tests shall be performed for N/O and N/C contacts.



#### 4.3 MECHANICAL REQUIREMENTS

##### 4.3.1 Dimension Check

The dimensions of the relays specified herein shall be verified in accordance with the requirements set out in Para. 9.23 of ESA/SCC Generic Specification No. 3601 and shall conform to those shown in Figure 2.

##### 4.3.2 Weight

The maximum weight of the relays specified herein shall be 41 grammes.

##### 4.3.3 Terminal Strength

The requirements for terminal strength testing are specified in Section 9 of ESA/SCC Generic Specification No. 3601. The test conditions shall be as follows:-

###### **Pull Test**

Applied Force: 50 Newtons.

Duration: 15 to 30 seconds.

#### 4.4 MATERIALS AND FINISHES

The materials and finishes shall be as specified herein. Where a definite material is not specified, a material which will enable the relays specified herein to meet the performance requirements of this specification shall be used. Acceptance or approval of any constituent material does not guarantee acceptance of the finished product.

##### 4.4.1 Case

Copper nickel, welded construction, Sn/Pb plated. Neither electro-deposited tin nor any paint shall be used.

##### 4.4.2 Terminal Material and Finish

The terminal material shall be Type 'H' with Type '3 or 4' finish in accordance with the requirements of ESA/SCC Basic Specification No. 23500.

#### 4.5 MARKING

##### 4.5.1 General

The marking of components delivered to this specification shall be in accordance with the requirements of ESA/SCC Basic Specification No. 21700 and the following paragraphs. When the component is too small to accommodate all of the marking specified, as much as space permits shall be marked and the marking information, in full, shall accompany the component in its primary package.

The information to be marked and the order of precedence, shall be as follows:-

- (a) Terminal Identification.
- (b) The SCC Component Number.
- (c) Electrical Characteristics.
- (d) Traceability Information.

##### 4.5.2 Terminal Identification

Terminal identification shall be marked on the relay can in accordance with Figure 3.

#### 4.5.3 The SCC Component Number

Each component shall bear the SCC Component Number which shall be constituted and marked as follows:

Detail Specification Number \_\_\_\_\_ 360100702B  
 Type Variant (see Table 1(a)) \_\_\_\_\_  
 Testing Level \_\_\_\_\_

#### 4.5.4 Electrical Characteristics

The electrical characteristic to be marked is the rated coil voltage. The information shall be constituted and marked as follows:-

Coil Voltage	Coil Resistance	Code
28Vdc	320Ω	28V
12Vdc	58Ω	12V
6.0Vdc	15Ω	6V

#### 4.5.5 Traceability Information

Each component shall be marked in respect of traceability information as defined in ESA/SCC Basic Specification No. 21700.

### 4.6 ELECTRICAL MEASUREMENTS

#### 4.6.1 Electrical Measurements at Room Temperature

The parameters to be measured at room temperature are scheduled in Table 2. Unless otherwise specified, the measurements shall be performed at  $T_{amb} = +22 \pm 3$  °C.

#### 4.6.2 Electrical Measurements at High and Low Temperatures

The parameters to be measured at high and low temperatures are scheduled in Table 3.

#### 4.6.3 Circuits for Electrical Measurements (Figure 4)

Not applicable.

### 4.7 SCREENING

#### 4.7.1 Miss Test

During the miss test, the contact resistance shall be continuously monitored and shall not exceed the values specified in Table 4 of this specification.

#### 4.7.2 Conditions for Screening

The requirements for screening are specified in Section 7 of ESA/SCC Generic Specification No. 3601. The conditions for screening shall be as specified in Table 5(a) of this specification.

#### 4.7.3 Electrical Circuits for Screening

Not applicable.



**TABLE 2 - ELECTRICAL MEASUREMENTS AT ROOM TEMPERATURE**

No.	CHARACTERISTICS	SYMBOL	ESA/SCC 3601 TEST METHOD	TEST CONDITION	LIMITS		UNIT
					MIN.	MAX.	
1	Pick-up Voltage:- 28V 12V 6V	$U_C$	Para. 9.3.1	Para. 9.3.1	- - -	13.5 6.5 3.2	V
2	Drop-out Voltage:- 28V 12V 6V	$U_d$	Para. 9.3.2	Para. 9.3.2	2.3 0.75 0.4	5.5 3.3 1.6	V
3	Operate Time	$t_C$	Para. 9.3.4	Para. 9.3.4	-	15	ms
4	Release Time	$t_d$	Para. 9.3.4	Para. 9.3.4	-	15	ms
5	Bounce Time	$t_b$	Para. 9.3.4	Para. 9.3.4	-	1.0	ms
6	Insulation Resistance	$R_i$	Para. 9.3.7	Para. 9.3.7 At 500Vdc	100	-	$M\Omega$
7	Voltage Proof	VP	Para. 9.3.6	Para. 9.3.6 Note 1	1250	-	Vrms
8	Contact Voltage Drop	$V_d$	Para. 9.3.3	Para. 9.3.3	-	150	mV
9	Coil Resistance:- 28V 12V 6V	$R_B$	Para. 9.3.5	Para. 9.3.5	290 52 13.5	350 64 16.5	$\Omega$

**NOTES**

1. 1000V between coil and case.

**TABLE 3 - ELECTRICAL MEASUREMENTS AT HIGH AND LOW TEMPERATURES**

No.	CHARACTERISTICS	SYMBOL	ESA/SCC 3601 TEST METHOD	TEST CONDITION	LIMITS		UNIT
					MIN.	MAX.	
1	Pick-up Voltage:- 28V 12V 6V	$U_C$	Para. 9.3.1	Para. 9.3.1	- - -	19.8 8.5 4.3	V
2	Drop-out Voltage:- 28V 12V 6V	$U_d$	Para. 9.3.2	Para. 9.3.2	1.5 0.5 0.25	7.0 4.5 2.3	V
3	Operate Time	$t_C$	Para. 9.3.4	Para. 9.3.4	-	15	ms
4	Release Time	$t_d$	Para. 9.3.4	Para. 9.3.4	-	15	ms
5	Bounce Time	$t_b$	Para. 9.3.4	Para. 9.3.4	-	1.0	ms
6	Insulation Resistance	$R_i$	Para. 9.3.7	Para. 9.3.7 At 500Vdc Note 1	50	-	$M\Omega$
8	Contact Voltage Drop	$V_d$	Para. 9.3.3	Para. 9.3.3	-	150	mV

**NOTES**

1. This measurement shall be made only at the high temperature condition.

**FIGURE 4 - CIRCUITS FOR ELECTRICAL MEASUREMENTS**

Not applicable.

**TABLE 4 - MEASUREMENTS DURING SCREENING**

No.	CHARACTERISTICS	SYMBOL	ESA/SCC 3601 TEST METHOD	TEST CONDITIONS	MAXIMUM LIMIT	UNIT
10	Miss Test, Contact Resistance	R <sub>C</sub>	Para. 9.8	Para. 9.8	100	Ω

**TABLE 5(a) - CONDITIONS FOR SCREENING**

No.	CHARACTERISTICS	SYMBOL	CONDITION	UNIT
1	Ambient High Temperature	T <sub>amb</sub>	+ 125(+ 0 - 3)	°C
2	Ambient Low Temperature	T <sub>amb</sub>	- 65(+ 3 - 0)	°C
3	Ambient Room Temperature	T <sub>amb</sub>	+ 22 ± 3	°C

**TABLE 5(b) - CONDITIONS FOR OPERATING LIFE TEST**

No.	CHARACTERISTICS	SYMBOL	CONDITION	UNIT
1	Ambient Temperature	T <sub>amb</sub>	+ 125(+ 0 - 3)	°C
2	Contact Load, Resistive	V I	28 15	Vdc Adc

**FIGURE 5(a) - ELECTRICAL CIRCUITS FOR SCREENING**

Not applicable.

**FIGURE 5(b) - ELECTRICAL CIRCUITS FOR OPERATING LIFE TESTS**

Not applicable.



- 4.8 ENVIRONMENTAL AND ENDURANCE TESTS (CHARTS IV AND V OF ESA/SCC GENERIC SPECIFICATION No. 3601)
- 4.8.1 Measurements and Inspections on Completion of Environmental Tests  
The parameters to be measured and inspections to be performed on completion of environmental tests are scheduled in Table 6. Unless otherwise stated, the measurements shall be performed at  $T_{amb} = +22 \pm 3$  °C.
- 4.8.2 Measurements and Inspections during Endurance Tests  
The parameters to be measured and inspections to be performed during endurance tests are scheduled in Table 6. Unless otherwise stated, the measurements shall be performed at  $T_{amb} = +22 \pm 3$  °C.
- 4.8.3 Measurements and Inspections on Completion of Endurance Tests  
The parameters to be measured and inspections to be performed on completion of endurance tests are scheduled in Table 6. Unless otherwise stated, the measurements shall be performed at  $T_{amb} = +22 \pm 3$  °C.
- 4.8.4 Conditions for Operating Life Tests (Part of Endurance Testing)  
The requirements for operating life testing are specified in Section 9 of ESA/SCC Generic Specification No. 3601. The conditions for operating life testing shall be as specified in Table 5(b) of this specification.
- 4.8.5 Electrical Circuits for Operating Life Tests (Figure 5(b))  
Not applicable.



**TABLE 6 - MEASUREMENTS AND INSPECTIONS ON COMPLETION OF ENVIRONMENTAL TESTS AND AT INTERMEDIATE POINTS AND ON COMPLETION OF ENDURANCE TESTING**

No.	ESA/SCC GÉNERIC SPEC. NO. 3601		MEASUREMENTS AND INSPECTIONS		SYMBOL	LIMITS		UNIT
	ENVIRONMENTAL AND ENDURANCE TESTS (1)	TEST METHOD AND CONDITIONS	IDENTIFICATION	CONDITIONS		MIN.	MAX.	
01	Vibration	Para. 9.10 and Para. 4.2.4 of this spec.	<b>Measurements during Test</b> Contact Monitoring  <b>Final Measurements</b> Visual Examination	ESA/SCC 3601 Para. 9.10  -	-  -	-  -	-  -	-  -
02	Mechanical Shock	Para. 9.11 and Para. 4.2.4 of this spec.	<b>Measurements during Test</b> Contact Monitoring  <b>Final Measurements</b> Electrical Measurements Visual Examination	ESA/SCC 3601 Para. 9.11  Table 2 Items 7-8-1-2 -	-  -	-  Table 2 -	-  -	-  -
03	Overload	Para. 9.12 and Table 1(b) Item 4 and Para. 4.2.4 of this spec.	<b>Measurements during Test</b> Contact Voltage Drop  <b>Final Measurements</b> Fuse Continuity Contact Voltage Drop Insulation Resistance Voltage Proof (all Points) Electrical Measurements	ESA/SCC 3601 Para. 9.12.2  - Table 2 Item 8 Table 2 Item 6 Table 2 Item 7 Table 2 Items 1-2-3-4-5-9	V <sub>d</sub>  - V <sub>d</sub> R <sub>i</sub> VP	Para. 9.12.2  Continuity - 225 50 - Table 2 Table 2	mV  mV MΩ Vrms	
04	Thermal Shock	Para. 9.13	<b>During 5th Cycle</b>  Electrical Measurements at +125°C Electrical Measurements at -65°C <b>Final Measurements</b> Visual Examination Voltage Proof (all Points)	In Conditioning Chamber Table 3 Items 1-2-3-4-7 Table 3 Items 1-2-3-4  - Table 2 Item 7	-  - VP	Table 3 Table 3  - Table 2	-  -	-  Vrms
05	Salt Spray	Para. 9.14	<b>Final Measurements</b> Visual Examination Electrical Measurements  Voltage Proof (all Points)	-  Table 2 Items 1-2-3-4-5-6-8-9 Table 2 Item 7	-  - VP	-  Table 2 Table 2	-  -	-  Vrms
06	Intermediate Current	Para. 9.16	<b>Measurements during Test</b> Contact Voltage Drop  <b>Final Measurements</b> Insulation Resistance Voltage Proof (all Points) Electrical Measurements  Contact Voltage Drop	ESA/SCC 3601 Para. 9.16.2  Table 2 Item 6 Table 2 Item 7 Table 2 Items 1-2-3-4-5-9 ESA/SCC 3601 Para. 9.16.2	V <sub>d</sub>  R <sub>i</sub> VP  V <sub>d</sub>	Para. 9.16.2  50 - Table 2 Table 2  Para. 9.16.2	mV  MΩ Vrms  mV	
07	Terminal Strength	Para. 9.17 and Para. 4.3.3 of this spec.	Visual Examination	ESA/SCC 3601 Para. 9.17.3	-	-	-	-

**NOTES**

1. The tests in this table refer to either Chart IV or V and shall be used as applicable.



**TABLE 6 - MEASUREMENTS AND INSPECTIONS ON COMPLETION OF ENVIRONMENTAL TESTS AND AT INTERMEDIATE POINTS AND ON COMPLETION OF ENDURANCE TESTING (CONT'D)**

No.	ESA/SCC GÉNERIC SPEC. NO. 3601		MEASUREMENTS AND INSPECTIONS		SYMBOL	LIMITS		UNIT
	ENVIRONMENTAL AND ENDURANCE TESTS (1)	TEST METHOD AND CONDITIONS	IDENTIFICATION	CONDITIONS		MIN.	MAX.	
08	Resistance to Soldering Heat	Para. 9.18	Electrical Measurements	Table 2 Items 1-2-6-8-9		Table 2		
09	Operating Life Resistive	Para's 9.19, 9.19.1 and Table 5(b) of this spec.	<b>Measurements during Test</b> Contact Voltage Drop  <b>Final Measurements</b> Fuse Continuity Contact Voltage Drop Insulation Resistance Voltage Proof (all Points) Electrical Measurements	ESA/SCC 3601 Para. 9.19.1  Table 2 Item 8 Table 2 Item 6 Table 2 Item 7 Table 2 Items 1-2-3-4-5-9	V <sub>d</sub>  - V <sub>d</sub> R <sub>i</sub> VP	Para. 9.19.1  Continuity - 225 50 - Table 2 Table 2	mV  mV MΩ Vrms	
10	Inductive Life	Para. 9.19.3 and Table 1(b) Item 5 of this spec.	<b>Measurements during Test</b> Contact Voltage Drop  <b>Final Measurements</b> Fuse Continuity Contact Voltage Drop Insulation Resistance Voltage Proof (all Points) Electrical Measurements	ESA/SCC 3601 Para. 9.19.1  Table 2 Item 8 Table 2 Item 6 Table 2 Item 7 Table 2 Items 1-2-3-4-5-9	V <sub>d</sub>  - V <sub>d</sub> R <sub>i</sub> VP	Para. 9.19.1  Continuity - 225 50 - Table 2 Table 2	mV  mV MΩ Vrms	
11	Mechanical Life	Para. 9.19.4	<b>Final Measurements</b> Contact Voltage Drop Electrical Measurements	Table 2 Item 8 Table 2 Items 1-2-3-4-5-9		- 175 Table 2	mV	
12	Coil Life	Para. 9.20	<b>Initial Measurements</b> Electrical Measurements <b>After 100 hours</b> Electrical Measurements at -65°C <b>At 250, 500, 750 hours</b> Electrical Measurements <b>During Last Cycle</b> Electrical Measurements at +125°C Electrical Measurements at -65°C <b>Final Measurements</b> Electrical Measurements Visual Examination	Table 2 Items 8-9  Table 2 Item 8 Table 3 Items 3-4  Table 2 Items 8-9  Table 3 Items 1-2  Table 3 Items 1-2  Table 2 Items 3 to 9		Table 2  Table 2 Table 3  Table 2  Table 3  Table 3  Table 2	-          -	

**NOTES**

1. The tests in this table refer to either Chart IV or V and shall be used as applicable.