





**european space agency  
agence spatiale européenne**

Pages 1 to 19

**POLYIMIDE INSULATED WIRES AND CABLES,  
LOW FREQUENCY, 600V, - 150 TO + 150 °C,  
BASED ON TYPE SPB 2110  
ESA/SCC Detail Specification No. 3901/008**

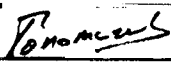

**space components  
coordination group**

Issue/Rev.	Date	Approved by	
		SCCG Chairman	ESA Director General or his Deputy
Issue 2	January 1996		



**DOCUMENTATION CHANGE NOTICE**

Rev. Letter	Rev. Date	Reference	CHANGE Item	Approved DCR No.
		This Issue supersedes Issue 1 and incorporates all modifications defined in Revision 'A' to Issue 1 and the changes agreed in the following DCR's:-		
		Cover Page		None
		DCN		None
		Para. 2	: Reference to MIL-STD-104 added	23791
		Para. 4.2.4	: Title amended	23791
		Para. 4.3.1	: Wording amended	23791
		Para. 4.4.1.1	: Paragraph standardised	23791
		Para. 4.4.1.2	: Paragraph standardised	23791
		Para. 4.4.3.2	: Paragraph standardised	23791
		Para. 4.5.2	: Wording amended	23791
		Para. 4.5.5	: Wording amended	23791
		Para. 4.8.2	: Sentence added	23791
		Para. 4.8.3	: Sentence added	23791
		Para. 4.8.7	: Sentence added	23791
		Para. 4.8.11	: Test '(h)' and '(i)' corrected to '(e)' and '(f)'	23791
		Para. 4.8.18	: Original paragraph deleted and Para. 4.8.19 renumbered to 4.8.18	23791
		Para. 4.8.19	: New paragraph added	23791

**TABLE OF CONTENTS**

	<u>Page</u>
<b>1. <u>GENERAL</u></b>	<b>5</b>
1.1 Scope	5
1.2 Type Variants	5
1.3 Maximum Ratings	5
1.4 Parameter Derating Information	5
1.5 Physical Characteristics	5
1.6 Functional Diagram	5
<b>2. <u>APPLICABLE DOCUMENTS</u></b>	<b>11</b>
<b>3. <u>TERMS, DEFINITIONS, ABBREVIATIONS, SYMBOLS AND UNITS</u></b>	<b>11</b>
<b>4. <u>REQUIREMENTS</u></b>	<b>11</b>
4.1 General	11
4.2 Deviations from Generic Specification	11
4.2.1 Deviations from Special In-process Controls	11
4.2.2 Deviations from Final Production Tests	11
4.2.3 Deviations from Burn-in and Electrical Measurements	11
4.2.4 Deviations from Qualification Tests	11
4.2.5 Deviations from Lot Acceptance Tests	11
4.3 Mechanical Requirements	12
4.3.1 Dimension Check	12
4.3.2 Weight	12
4.4 Materials and Finishes	13
4.4.1 Conductor	13
4.4.2 Insulation	13
4.4.3 Shield	13
4.4.4 Jacket	14
4.4.5 Construction of Multicore Cables	14
4.4.6 Colour Coding	14
4.5 Marking	15
4.5.1 General	15
4.5.2 The SCC Component Number	15
4.5.3 Characteristics	16
4.5.4 Traceability Information	16
4.5.5 Additional Marking	16
4.6 Electrical Measurements	16
4.6.1 Electrical Measurements at Room Temperature	16
4.6.2 Electrical Measurements at High and Low Temperatures	16
4.6.3 Circuits for Electrical Measurements	16
4.7 Burn-in Tests	16
4.8 Environmental and Endurance Tests	16
4.8.1 Mechanical Properties of Conductor	16
4.8.2 Accelerated Ageing	16
4.8.3 Wrap Test at Ambient Temperature	17
4.8.4 Voltage Test	18
4.8.5 Shrinkage	18
4.8.6 Blocking	18
4.8.7 Cold Bend Test	18



	<u>Page</u>
4.8.8 Cut-through Resistance	18
4.8.9 Notch Resistance	18
4.8.10 Flammability	18
4.8.11 Resistance to Fluids	18
4.8.12 Surface Resistance	18
4.8.13 Abrasion Resistance	19
4.8.14 Soldering	19
4.8.15 Solderability	19
4.8.16 Radiation Resistance	19
4.8.17 Overload Resistance	19
4.8.18 Long-term Ageing Test	19
4.8.19 Anthony and Brown Test	19

### **TABLES**

1(a) Type Variants	6
1(b) Maximum Ratings	9
A Mandrel Diameters and Loads for Finished Wires	17
B Mandrel Diameters and Loads for Shielded and Jacketed Cables	17
C Mandrel Diameters and Loads for Finished Wires or Cores	18
2 Electrical Measurements at Room Temperature	19

### **FIGURES**

1 Parameter Derating Information	9
2 Physical Characteristics	10

### **APPENDICES (Applicable to specific Manufacturers only)**

None.

**1. GENERAL****1.1 SCOPE**

This specification details the ratings, physical and electrical characteristics, test and inspection data for Polyimide Insulated Wires and Cables, Low Frequency, 600V, -150 to +150 °C, based on Type SPB 2110. It shall be read in conjunction with ESA/SCC Generic Specification No. 3901, the requirements of which are supplemented herein.

**NOTES**

1. These wires and cables shall not be used in the presence or vicinity of hydrazine or nitrogen tetroxide.

**1.2 TYPE VARIANTS**

Variants of the basic types of wires and cables specified herein which are also covered by this specification, are listed in Table 1(a).

**1.3 MAXIMUM RATINGS**

The maximum ratings, applicable to the finished wires and cables specified herein, which shall not be exceeded at any time during use or storage in controlled space environment, are scheduled in Table 1(b).

**1.4 PARAMETER DERATING INFORMATION**

The derating information applicable to the finished wires and cables specified herein is as follows:

- The maximum current for each wire used in a bundle shall be:-

$$I_{Bmax} = I_{max} \times \frac{29 - n}{28} \quad (\text{for } 1 < n < 15)$$

$$I_{Bmax} = \frac{I_{max}}{2} \quad (\text{for } n > 15)$$

where n = number of wires in the bundle;

- The temperature derating information is shown in Figure 1 with maximum current  $I_{max}$  for a single wire.
- The derating factors contained herein indicate maximum stress values and do not preclude further derating.

**1.5 PHYSICAL CHARACTERISTICS**

The physical characteristics of the finished wires and cables specified herein are shown in Figures 2(a), 2(b) and 2(c) and their dimensions in Table 1(a).

**1.6 FUNCTIONAL DIAGRAM**

Not applicable.



**SCS**

ESA/SCC Detail Specification

No. 3901/008

PAGE 6

ISSUE 2

**TABLE 1(a) - TYPE VARIANTS**

VARIANT No.	SHIELDED		UN-SHIELDED	No. OF CORES	WIRE SIZE AWG	STRANDING No. OF STRANDS x DIAMETER (mm)	CONDUCTOR CHARACTERISTICS			SHIELD STRAND Ø (mm)	CORE MAX Ø (mm)	FINISHED WIRE OR CABLE CHARACTERISTICS	
	1 SHIELD	2 SHIELDS					MAX Ø (mm)	NOM SECT. (mm <sup>2</sup> )	MAX OHMIC RESISTANCE (Ω/km)			MAX Ø (mm)	MAX WEIGHT (kg/km)
01			X	1	28	7 x 0.127	0.40	0.09	253	-	-	1.08	2.35
02			X	1	26	19 x 0.102	0.54	0.15	147	-	-	1.20	3.15
03			X	1	24	19 x 0.127	0.67	0.24	94	-	-	1.35	4.17
04			X	1	22	19 x 0.160	0.84	0.38	49.5	-	-	1.51	5.81
05			X	1	20	19 x 0.203	1.05	0.62	30.2	-	-	1.71	8.36
06			X	1	16	19 x 0.287	1.48	1.23	15.0	-	-	2.25	15.62
07			X	1	12	37 x 0.320	2.29	2.88	6.3	-	-	3.06	34.59
08			X	2	28	7 x 0.127	0.40	0.09	258	-	1.08	2.16	5.49
09			X	2	26	19 x 0.102	0.54	0.15	150	-	1.20	2.40	7.11
10			X	2	24	19 x 0.127	0.67	0.24	96	-	1.35	2.70	9.52
11			X	2	22	19 x 0.160	0.84	0.38	50.5	-	1.51	3.02	13.07
12			X	2	20	19 x 0.203	1.05	0.62	30.5	-	1.71	3.42	19.50
13			X	2	16	19 x 0.287	1.48	1.23	15.3	-	2.25	4.50	34.94
14			X	2	12	37 x 0.320	2.29	2.88	6.4	-	3.06	6.12	76.64
15			X	3	26	19 x 0.102	0.54	0.15	150	-	1.20	2.58	10.36
16			X	3	24	19 x 0.127	0.67	0.24	96	-	1.35	2.90	13.78
17			X	3	22	19 x 0.160	0.84	0.38	50.5	-	1.51	3.25	19.05
18			X	3	20	19 x 0.203	1.05	0.62	30.5	-	1.71	3.68	28.38
19			X	3	16	19 x 0.287	1.48	1.23	15.3	-	2.25	4.84	53.16
20			X	3	12	37 x 0.320	2.29	2.88	6.4	-	3.06	6.58	112.39
21			X	4	26	19 x 0.102	0.54	0.15	151	-	1.20	2.94	14.16
22			X	4	24	19 x 0.127	0.67	0.24	97	-	1.35	3.26	18.49
23			X	4	22	19 x 0.160	0.84	0.38	51	-	1.51	3.70	24.97
24			X	4	20	19 x 0.203	1.05	0.62	31.1	-	1.71	4.19	36.92
25			X	4	16	19 x 0.287	1.48	1.23	15.4	-	2.25	5.51	63.81



**SEC**

ESA/SCC Detail Specification

No. 3901/008

PAGE 7

ISSUE 2

**TABLE 1(a) - TYPE VARIANTS (CONTINUED)**

VARIANT No.	SHIELDED		UN-SHIELDED	No. OF CORES	WIRE SIZE AWG	STRANDING No. OF STRANDS x DIAMETER (mm)	CONDUCTOR CHARACTERISTICS			SHIELD STRAND Ø (mm)	CORE MAX Ø (mm)	FINISHED WIRE OR CABLE CHARACTERISTICS	
	1 SHIELD	2 SHIELDS					MAX Ø (mm)	NOM SECT. (mm <sup>2</sup> )	MAX OHMIC RESISTANCE (Ω/km)			MAX Ø (mm)	MAX WEIGHT (kg/km)
26			X	4	12	37 x 0.320	2.29	2.88	6.5	-	3.06	7.50	151.23
27			X	5	26	19 x 0.102	0.54	0.15	152	-	1.20	3.24	19.11
28			X	5	24	19 x 0.127	0.67	0.24	97.5	-	1.35	3.65	25.31
29			X	5	22	19 x 0.160	0.84	0.38	51.3	-	1.51	4.08	34.85
30			X	5	20	19 x 0.203	1.05	0.62	31.3	-	1.71	4.62	50.81
31			X	7	26	19 x 0.102	0.54	0.15	153	-	1.20	3.60	24.05
32			X	7	24	19 x 0.127	0.67	0.24	98	-	1.35	4.05	32.20
33			X	7	22	19 x 0.160	0.84	0.38	51.5	-	1.51	4.53	45.95
34			X	7	20	19 x 0.203	1.05	0.62	31.4	-	1.71	5.13	64.79
35	X			1	28	7 x 0.127	0.40	0.09	253	0.102	-	1.92	8.32
36	X			1	26	19 x 0.102	0.54	0.15	147	0.102	-	2.04	9.27
37	X			1	24	19 x 0.127	0.67	0.24	94	0.102	-	2.19	11.12
38	X			2	28	7 x 0.127	0.40	0.09	258	0.102	1.08	3.00	13.94
39	X			2	26	19 x 0.102	0.54	0.15	150	0.102	1.20	3.24	16.25
40	X			2	24	19 x 0.127	0.67	0.24	96	0.102	1.35	3.54	19.64
41	X			2	22	19 x 0.160	0.84	0.38	50.5	0.102	1.51	3.86	29.18
42	X			2	20	19 x 0.203	1.05	0.62	30.5	0.102	1.71	4.26	38.97
43	X			2	16	19 x 0.287	1.48	1.23	15.3	0.127	2.25	5.54	57.14
44	X			2	12	37 x 0.320	2.29	2.88	6.4	0.127	3.06	7.16	106.26
45	X			3	26	19 x 0.102	0.54	0.15	150	0.102	1.20	3.42	19.91
46	X			3	24	19 x 0.127	0.67	0.24	96	0.102	1.35	3.74	24.37
47	X			3	22	19 x 0.160	0.84	0.38	50.5	0.102	1.51	4.09	36.34
48	X			3	20	19 x 0.203	1.05	0.62	30.5	0.127	1.71	4.72	47.96
49	X			3	16	19 x 0.287	1.48	1.23	15.3	0.127	2.25	5.88	78.94
50	X			3	12	37 x 0.320	2.29	2.88	6.4	0.127	3.06	7.62	145.79



**SCS**

ESA/SCC Detail Specification

No. 3901/008

PAGE 8

ISSUE 2

**TABLE 1(a) - TYPE VARIANTS (CONTINUED)**

VARIANT No.	SHIELDED		UN-SHIELDED	No. OF CORES	WIRE SIZE AWG	STRANDING No. OF STRANDS x DIAMETER (mm)	CONDUCTOR CHARACTERISTICS			SHIELD STRAND Ø (mm)	CORE MAX Ø (mm)	FINISHED WIRE OR CABLE CHARACTERISTICS	
	1 SHIELD	2 SHIELDS					MAX Ø (mm)	NOM SECT. (mm <sup>2</sup> )	MAX OHMIC RESISTANCE (Ω/km)			MAX Ø (mm)	MAX WEIGHT (kg/km)
51	X			4	26	19X0.102	0.54	0.15	151	0.102	1.20	3.88	25.33
52	X			4	24	19X0.127	0.67	0.24	97	0.102	1.35	4.15	34.25
53	X			4	22	19X0.160	0.84	0.38	51	0.127	1.51	4.74	44.18
54	X			4	20	19X0.203	1.05	0.62	31.1	0.127	1.71	5.23	62.55
55	X			4	16	19X0.287	1.48	1.23	15.4	0.127	2.25	6.55	96.43
56	X			4	12	37X0.320	2.29	2.88	6.5	0.127	3.06	8.54	186.78
57	X			5	26	19X0.102	0.54	0.15	152	0.102	1.20	4.08	33.10
58	X			5	24	19X0.127	0.67	0.24	97.5	0.102	1.35	4.69	40.35
59	X			5	22	19X0.160	0.84	0.38	51.3	0.127	1.51	5.12	57.51
60	X			5	20	19X0.203	1.05	0.62	31.3	0.127	1.71	5.66	78.53
61	X			7	26	19X0.102	0.54	0.15	153	0.102	1.20	4.64	41.04
62	X			7	24	19X0.127	0.67	0.24	98	0.127	1.35	5.09	50.70
63	X			7	22	19X0.160	0.84	0.38	51.5	0.127	1.51	5.57	70.81
64	X			7	20	19X0.203	1.05	0.62	31.4	0.127	1.71	6.17	94.49
65		X		2	20	19X0.203	1.05	0.62	30.5	0.102/0.102	1.71	5.04	55.77
66		X		4	20	19X0.203	1.05	0.62	31.1	0.127/0.127	1.71	5.82	79.59





**TABLE 1(b) - MAXIMUM RATINGS**

No.	CHARACTERISTICS	SYMBOL	MAXIMUM RATINGS	UNIT	REMARKS
1	Voltage	$V_p$	600	Vrms	
2	Maximum Current (Note 1)	$I_{max}$	1.5 2.5 3.5 5.0 7.5 13.0 25.0	A	For AWG 28 26 24 22 20 16 12
3	Operating Temperature Range	$T_{amb}$	- 150 to + 150	°C	
4	Storage Temperature Range	$T_{stg}$	- 150 to + 150	°C	

**NOTES**

- The above specified current will generate a temperature rise of approximately 50°C above ambient temperature in a vacuum environment. Precautions shall be taken to prevent the total temperature of the wire (ambient plus rise) exceeding the continuous operating temperature of the wire.

**FIGURE 1 - PARAMETER DERATING INFORMATION**

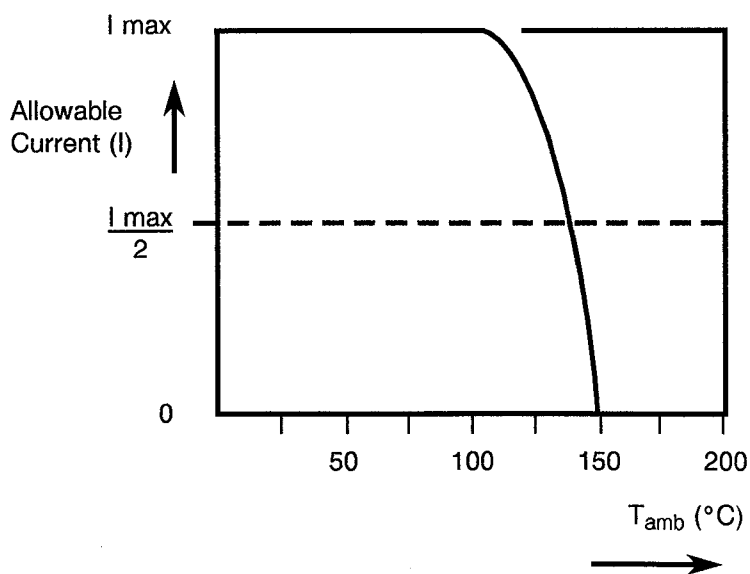

Allowable Current versus Temperature



**FIGURE 2 - PHYSICAL CHARACTERISTICS**

Dimensions are given in Table 1(a)

**FIGURE 2(a) - FINISHED WIRES**

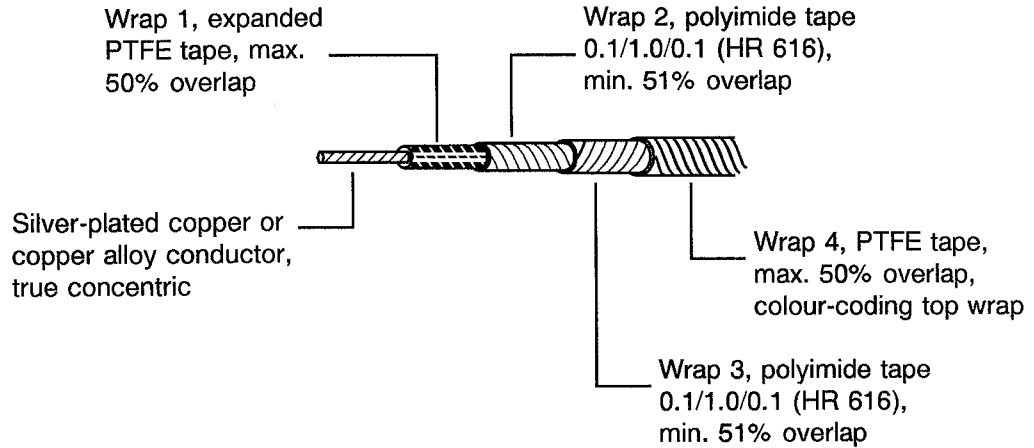

**FIGURE 2(b) - SHIELDED AND JACKETED CABLES**

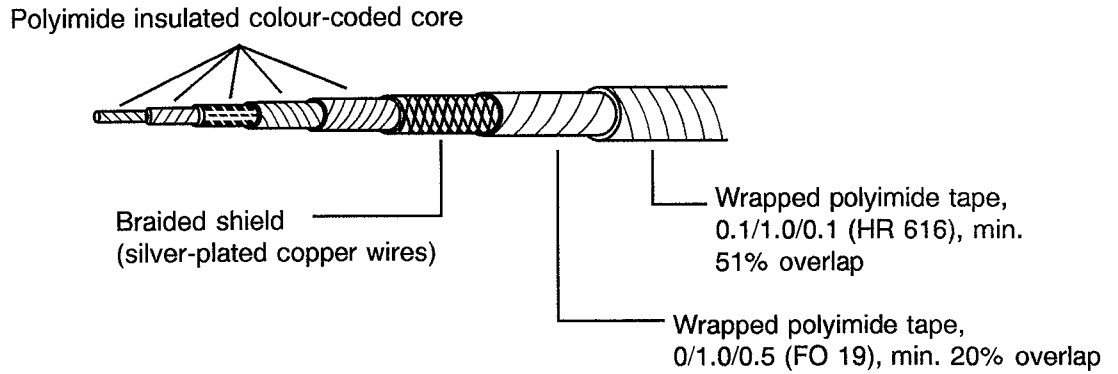

**FIGURE 2(c) - SHIELDED AND JACKETED CABLES**

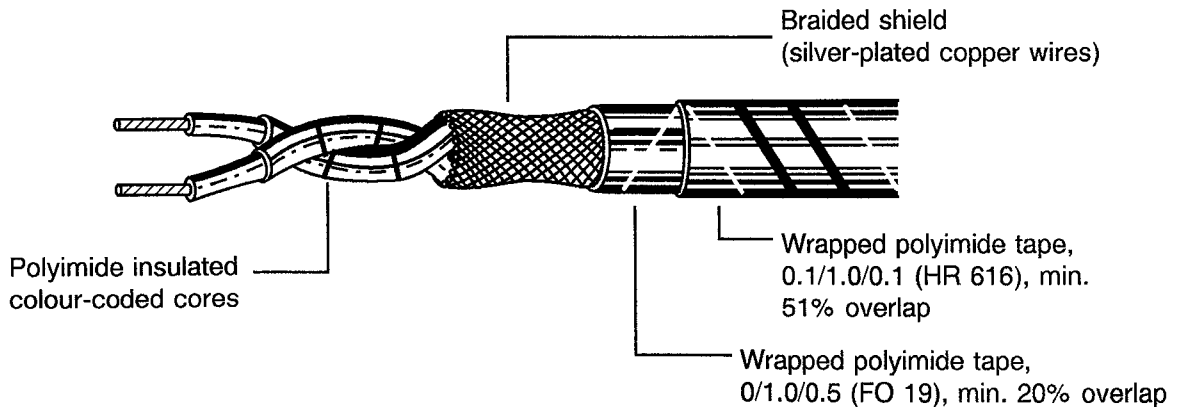

**2. APPLICABLE DOCUMENTS**

The following documents form part of this specification and shall be read in conjunction with it:

- (a) ESA/SCC Generic Specification No. 3901, "Wires and Cables, Electrical, 600V, Low Frequency".
- (b) MIL-STD-104, "Limits for Electrical Insulation Coloured".

**3. TERMS, DEFINITIONS, ABBREVIATIONS, SYMBOLS AND UNITS**

For the purpose of this specification, the terms, definitions, abbreviations, symbols and units specified in ESA/SCC Basic Specification No. 21300 and ESA/SCC Generic Specification No. 3901 shall apply.

**4. REQUIREMENTS****4.1 GENERAL**

The complete requirements for procurement of the finished wires and cables specified herein are stated in this specification and ESA/SCC Generic Specification No. 3901. Deviations from the Generic Specification, applicable to this specification only, are listed in Para 4.2.

Deviations from the applicable Generic Specification and this Detail Specification, formally agreed with specific Manufacturers on the basis that the alternative requirements are equivalent to the ESA/SCC requirements and do not affect the components' reliability, are listed in the Appendices attached to this specification.

**4.2 DEVIATIONS FROM GENERIC SPECIFICATION****4.2.1 Deviations from Special In-process Controls**

None.

**4.2.2 Deviations from Final Production Tests (Chart II)**

None.

**4.2.3 Deviations from Burn-in and Electrical Measurements (Chart III)**

Not applicable.

**4.2.4 Deviations from Qualification Tests (Chart IV)**

- (a) Para. 9.21, "Resistance to Fluids": To be modified as stated in Para. 4.8.11 of this specification.

**4.2.5 Deviations from Lot Acceptance Tests (Chart V)**

None.

**4.3 MECHANICAL REQUIREMENTS****4.3.1 Dimension Check**

The dimensions of the finished wires and cables specified herein shall be checked; they shall conform to those shown in Table 1(a), Figure 2 and Para 4.4 of this specification (see below for the list of parameters to be checked).

**LIST OF PARAMETERS TO BE CHECKED**

PARAMETER	TABLE 1(a)	FIGURE 2	PARA 4.4
<b><u>COMPOSITION</u></b>			
Number of conductors	X		
Gauge	X		
Shielding	X		
Jacket		X	
<b><u>CONDUCTOR</u></b>			
Nature			X
Outer diameter	X		
Number of strands	X		
Strand diameter	X		
Length of lay			X
Silver thickness			X
<b><u>INSULATION</u></b>			
Composition		X	X
Protective coating		X	X
Thickness			X
Overlapping			X
Outer diameter	X		
<b><u>SHIELDING</u></b>			
Number of strands	X		
Type of shielding			X
Strand diameter	X		
Nature		X	X
Silver thickness			X
Shielding lay			X
Shield coverage			X
<b><u>JACKET</u></b>			
Composition		X	X
Protective tape wraps		X	X
Thickness			X
Overlapping			X
Outer diameter	X		

**4.3.2 Weight**

The maximum weight of the finished wires and cables specified herein shall be as specified in Table 1(a).



#### 4.4 MATERIALS AND FINISHES

The materials and finishes shall be as specified herein. Where a definite material is not specified, a material which will enable the wires and cables specified herein to meet the performance requirements of this specification shall be used. Acceptance or approval of any constituent material does not guarantee acceptance of the finished product.

##### 4.4.1 Conductor

###### 4.4.1.1 Material Characteristics

All strands used in the manufacture of the conductors shall be silver-coated, soft or annealed, oxygen-free high conductivity copper from AWG 12 to 22 inclusive and silver-coated, high strength copper alloy from AWG 24 to 28. On silver-coated strands, the thickness of silver shall be 2.0 microns minimum.

On all copper conductors, any strand shall show a 10% minimum elongation. On all high-strength copper alloy conductors, any strand shall show a 6% minimum elongation at break and a 350N/mm<sup>2</sup> minimum tensile strength.

The resistance of the conductors shall be determined at +20°C in accordance with Para. 9.5 of ESA/SCC Generic Specification No. 3901, where the 'α' coefficient for copper alloy is 0.0035.

###### 4.4.1.2 Stranding

The conductors shall be constructed of concentrically laid strands to produce a smooth and uniform conductor of circular cross-section and free from any high strands or other surface irregularities.

The length of lay of the external layer shall not be less than 8, nor more than 16, times the maximum conductor diameter specified in Table 1(a).

##### 4.4.2 Insulation

###### 4.4.2.1 Material

Any insulating material shall be virgin polyimide with only those additives that are necessary for processing and pigmentation.

###### 4.4.2.2 Construction

The insulation shall have a uniform cross-section throughout the length of the cable and the conductor shall be evenly centred in the insulation.

The insulation shall consist of 2 wrapped layers of polyimide tapes as specified in Figure 2(a).

##### 4.4.3 Shield

###### 4.4.3.1 Material

Shield strands shall meet the requirements for silver-coated annealed copper as outlined in Para. 4.4.1.1 of this specification, but the thickness of silver shall be 2.5 microns minimum.



#### 4.4.3.2 Construction

Shields shall be closely woven braid. The strand sizes for the shields shall be as specified in Table 1(a) of this specification.

The shield braid shall be a push-back type. The angle of the carriers of the braid with the axis of the cable shall not be less than 10, nor more than 40, degrees.

The shield braid shall be applied in such a manner as to provide a coverage of not less than 90%. The coverage factor 'K' is calculated by the following formula:

$$K = (2F - F^2) \times 100.$$

where:-

K = percent coverage.

$$F = \frac{N \cdot d \cdot P}{\sin a}$$

where:-

N = number of strands per carrier.

d = diameter of strands (mm).

P = picks per mm.

a = angle of shield with cable axis in degrees.

$$\tan a = \frac{2(D + 2d)P}{C}$$

where:-

D = effective diameter of cable under shield (mm).

C = number of carriers.

#### 4.4.4 Jacket

All shielded cables shall be provided with jackets of wrapped polyimide tapes as specified in Figures 2(b) and 2(c). The wrapped tapes shall be heat-sealed. The side of the tape of the first layer above the shield, which is not coated with FEP resin, shall be facing the shield.

#### 4.4.5 Construction of Multicore Cables

Multicore cables shall be constructed by twisting the required number and size of finished wires to form a uniform cable without high strands, bends or other irregularities. Finished wires of only one size shall be used for one cable. The cabling shall be with a left-hand lay and the lay length shall not be less than 12 times and not be more than 16 times the outside diameter of the unshielded unjacketed cable. The construction of shielded and jacketed cables is shown in Figure 2(c) (double-shielded cable not shown). Fillers shall not be used in the construction of multicore cables except for the 5-core cable, where the 5 wires shall be twisted around a round, uncoloured PTFE-filler. The diameter of the PTFE-filler for the 5-conductor cable shall be 0.7 times the diameter of the conductors used in the cable.

Double-shielded cables shall be constructed with a wrap of 0/0.5/0-tape in left-hand lay and at least 51% overlap over the first shield. This shall be followed by the second shield which shall also conform to the requirements of Para. 4.4.3 and a jacket as specified in Para. 4.4.4.

#### 4.4.6 Colour-coding

##### 4.4.6.1 Finished Wire Colour-coding

The colour of the finished wires shall be the natural colour of the top wrap on the insulation except when colouring is specifically required in the contract.

##### Colours

- Black (not preferred)
- Brown



- Red
- Orange (not preferred)
- Yellow
- Green
- Blue
- Violet (not preferred)
- Grey
- White
- Natural

The colour of top wraps shall conform to the colour limits specified in MIL-STD-104, Class 1.

4.4.6.2 Multicore Cable Colour-coding

If the contract does not define any specific colour-coding, all individual cores in multicore cables shall have the natural colour. If colour-coding is desired, it is proposed that the individual cores in such cables shall be coloured according to the following scheme:-

Number of cores in cable	Colour of respective cores						
2	red	blue					
3	red	blue	yellow				
4	red	blue	yellow	green			
5	red	blue	yellow	green	brown		
6	red	blue	yellow	green	brown	grey	
7	red	blue	yellow	green	brown	grey	white

4.4.6.3 Jacket Colour

The colour of jackets shall normally be the natural colour of the polyimide tapes.

4.5 MARKING

4.5.1 General

The marking of all spools of finished wires and cables delivered to this specification shall be in accordance with the requirements of ESA/SCC Basic Specification No. 21700. Each spool shall be marked in respect of:-

- (a) The SCC Component Number.
- (b) Characteristics.
- (c) Traceability Information.
- (d) Additional Markings.

4.5.2 The SCC Component Number

Each spool shall bear the SCC Component Number which shall be constituted and marked as follows:-

390100802B

Detail Specification Number \_\_\_\_\_

Type Variant (see Table 1(a)) \_\_\_\_\_

Testing Level \_\_\_\_\_



#### 4.5.3 Characteristics

The characteristics shall show the length(s) of finished wire or cable wound on each spool and shall be marked as follows:-

Length in metres (see Note) \_\_\_\_\_ 100m  
Symbol for metres \_\_\_\_\_

#### **NOTE**

Whenever the length is less than 100 metres, insert a zero in the first block (example: 075m). If more than one length of finished wire or cable is wound on a spool, the characteristics of each length shall be marked as above.

#### 4.5.4 Traceability Information

Each spool shall be marked in respect of traceability information in accordance with the requirements of ESA/SCC Basic Specification No. 21700.

#### 4.5.5 Additional Marking

Each spool shall bear the cable manufacturer's Quality Control Inspector's stamp and initials.

### 4.6 ELECTRICAL MEASUREMENTS

#### 4.6.1 Electrical Measurements at Room Temperature

The parameters to be measured at room temperature are scheduled in Table 2. The measurements shall be performed at  $T_{amb} = +22 \pm 3$  °C.

#### 4.6.2 Electrical Measurements at High and Low Temperatures

Not applicable.

#### 4.6.3 Circuits for Electrical Measurements

Not applicable.

### 4.7 BURN-IN TESTS

Not applicable.

### 4.8 ENVIRONMENTAL AND ENDURANCE TESTS

#### 4.8.1 Mechanical Properties of Conductor

As detailed in Para. 4.4.1.1 of this Specification.

#### 4.8.2 Accelerated Ageing

Ageing Temperature  $+230 \pm 5$  °C.

The mandrel diameter and appropriate weight used for accelerated age testing of the finished wires is given in Table A.



**TABLE A - MANDREL DIAMETERS AND LOADS FOR FINISHED WIRES**

Wire Size (AWG)	Mandrel Diameter (mm)	Weight (kg)
28	6.0	0.25
26	6.0	0.25
24	6.0	0.25
22	6.0	0.4
20	6.0	0.4
16	10	0.5
12	20	1.0

**4.8.3 Wrap Test at Ambient Temperature**

The mandrel diameters and applied loads for wrap testing of finished wires are given in Table A. The mandrel diameters and applied loads for screened and jacketed cables are given in Table B.

**TABLE B - MANDREL DIAMETERS AND LOADS FOR SHIELDED AND JACKETED CABLES**

Cable Size (AWG)	Number of Cores	Mandrel Diameter (mm)	Load (kg)
28	1	8.0	0.25
26	1	10	0.25
24	1	12	0.25
28	2	12	0.5
26	2	15	0.5
24	2	15	0.5
22	2	20	0.8
20	2	20	0.8
16	2	25	1.0
12	2	30	1.0
26	3	15	0.75
24	3	15	0.75
22	3	20	1.2
20	3	20	1.2
16	3	30	1.5
12	3	40	1.5
26	4	15	1.0
24	4	20	1.0
22	4	20	1.5
20	4	25	1.5
16	4	30	1.5
12	4	40	1.5
26	5	20	1.5
24	5	20	1.5
22	5	25	2.0
20	5	30	2.0
26	7	20	1.5
24	7	20	1.5
22	7	25	2.0
20	7	30	2.0



4.8.4 Voltage Test

No particular conditions are applicable.

4.8.5 Shrinkage

The shrinkage temperature shall be  $+230 \pm 5$  °C

4.8.6 Blocking

The blocking temperature shall be  $+200 \pm 5$  °C.

4.8.7 Cold Bend Test

The mandrel diameters and loads shall be as specified in Table C.

**TABLE C - MANDREL DIAMETERS AND LOADS FOR FINISHED WIRES OR CORES**

Wire Size (AWG)	Mandrel Diameter (mm)	Weight (kg)
28	6.0	0.25
26	6.0	0.25
24	6.0	0.25
22	6.0	0.4
20	6.0	0.4
16	10	0.5
12	20	1.0

4.8.8 Cut-through Resistance

The mean load measured during the required tests shall not be less than the relevant value specified below:-

Wire Size (AWG)	28	26	24	22	20	16	12
Cut-through Load (kg)	12	15	17	21	26	43	66

4.8.9 Notch Resistance

The depth of notch shall be 0.04mm.

4.8.10 Flammability

No particular conditions are applicable.

4.8.11 Resistance to Fluids

Tests (e) and (f) shall not be performed.

4.8.12 Surface Resistance

No particular conditions are applicable.

**4.8.13 Abrasion Resistance**

The weight to be applied to the needle is specified below:-

Wire Size (AWG)	28	26	24	22	20	16	12
Scrape Abrasion Load (g)	500	650	750	800	900	1050	1200

**4.8.14 Soldering**

No particular conditions are applicable.

**4.8.15 Solderability**

No particular conditions are applicable.

**4.8.16 Radiation Resistance**

No particular conditions are applicable.

**4.8.17 Overload Resistance**

No particular conditions are applicable.

**4.8.18 Long-term Ageing Test**

The long-term ageing temperature shall be +200°C.

**4.8.19 Anthony and Brown Test**

No particular conditions are applicable.

**TABLE 2 - ELECTRICAL MEASUREMENTS AT ROOM TEMPERATURE**

No.	CHARACTERISTICS	SPEC. AND/OR TEST METHOD	TEST CONDITION	LIMITS	UNIT
1	Conductor Resistance	ESA/SCC No. 3901, Section 9	Para 9.5	Table 1(a)	Ω/km
2	Spark Test	ESA/SCC No. 3901, Section 9	Para 9.6	Insulation : 3 Jacket : 1.5	kV
3	Voltage Test	ESA/SCC No. 3901, Section 9	Para 9.7	Para 9.7	kV
4	Insulation Resistance	ESA/SCC No. 3901, Section 9	Para 9.8	Insulation : 750 Jacket : 30	MΩ.km
5	Surface Resistance	ESA/SCC No. 3901, Section 9	Para 9.22	: 125	MΩ.mm