





europaean space agency  
agence spatiale européenne

Pages 1 to 22

**EXTRUDED, CROSS-LINKED MODIFIED ETFE  
INSULATED WIRES AND CABLES ON  
SILVER-PLATED COPPER CONDUCTOR,  
LIGHTWEIGHT, SPIRAL SHIELDED  
(WITH AND WITHOUT DRAIN WIRES)  
LOW FREQUENCY, 600V, - 100 TO + 200 °C  
ESA/SCC Detail Specification No. 3901/022**



**space components  
coordination group**

Issue/Rev.	Date	Approved by	
		SCCG Chairman	ESA Director General or his Deputy
Issue 2	November 2000		

**DOCUMENTATION CHANGE NOTICE**

Rev. Letter	Rev. Date	Reference	CHANGE Item	Approved DCR No.
		This Issue supersedes Issue 1 and incorporates all modifications defined in Revisions 'A' and 'B' to Issue 1 and the changes agreed in the following DCRs:-		
		Cover page	: Title amended to read, "(With and Without Drain Wires)"	221557
		DCN		None
		Para. 1.1	: Text amended to read, "(With and Without Drain Wires)"	221557
		Table 1(a)	: New column "Drain Wire" added	221557
			: Variants 25 to 72 inclusive added	221557
		Table 1(b)	: 3 additions to Maximum Current Ratings	221557
		Figure 2	: New Figures "2(d)" and "2(e)" added	221557
		Para. 4.3.1	: New parameter "Drain Wire" added	221557
		Para. 4.4.3	: In first sentence, text amended to read, "... left hand ..."	221557
			: New last sentence added	221557
		Para. 4.4.2.2	: First sentence amended	221557
		Para. 4.4.5	: New paragraph added	221557
		Para. 4.4.5	: Renumbered as "4.4.6"	221557
		Para. 4.5.3	: Variants "25 to 27 and 37 to 45" added to Single Conductors	221557
			: Variants "28 to 30 and 46 to 54" added to Two Conductors	221557
			: Variants "31 to 33 and 55 to 63" added to Three Conductors	221557
			: Variants "34 to 36 and 64 to 72" added to Four Conductors	221557
		Table A	: 3 additions to Table values	221557
		Table B	: 3 additions to Table values	221557
		Table C	: 3 additions to Table values	221557
		Para. 4.8.8	: 3 additions to Table	221557
		Para. 4.8.13	: 3 additions to Table	221557
			: Scrape abrasion value amended for 0.60mm <sup>2</sup>	221574
		Appendix 'A'	: Manufacturer name changed	221557

**TABLE OF CONTENTS**

	<u>Page</u>
<b>1. <u>GENERAL</u></b>	<b>5</b>
1.1 Scope	5
1.2 Type Variants	5
1.3 Maximum Ratings	5
1.4 Parameter Derating Information	5
1.5 Physical Characteristics	5
1.6 Functional Diagram	5
<b>2. <u>APPLICABLE DOCUMENTS</u></b>	<b>12</b>
<b>3. <u>TERMS, DEFINITIONS, ABBREVIATIONS, SYMBOLS AND UNITS</u></b>	<b>12</b>
<b>4. <u>REQUIREMENTS</u></b>	<b>12</b>
4.1 General	12
4.2 Deviations from Generic Specification	12
4.2.1 Deviations from Special In-process Controls	12
4.2.2 Deviations from Final Production Tests	12
4.2.3 Deviations from Burn-in and Electrical Measurements	12
4.2.4 Deviations from Qualification Tests	12
4.2.5 Deviations from Lot Acceptance Tests	12
4.3 Mechanical Requirements	13
4.3.1 Dimension Check	13
4.3.2 Weight	13
4.4 Materials and Finishes	14
4.4.1 Conductor	14
4.4.2 Insulation	14
4.4.3 Assembly	15
4.4.4 Shield	15
4.4.5 Drain Wire	15
4.4.6 Jacket	16
4.5 Marking	16
4.5.1 General	16
4.5.2 The SCC Component Number	16
4.5.3 Characteristics	16
4.5.4 Traceability Information	17
4.5.5 Additional Marking	17
4.6 Electrical Measurements	17
4.6.1 Electrical Measurements at Room Temperature	17
4.6.2 Electrical Measurements at High and Low Temperatures	17
4.6.3 Circuits for Electrical Measurements	17
4.7 Burn-in Tests	17
4.8 Environmental and Endurance Tests	18
4.8.1 Mechanical Properties of Conductor	18
4.8.2 Accelerated Ageing	18
4.8.3 Wrap Test at Ambient Temperature	18
4.8.4 Voltage Test	18
4.8.5 Shrinkage	18
4.8.6 Blocking	18
4.8.7 Cold Bend Test	18
4.8.8 Cut-through Resistance	20
4.8.9 Notch Resistance	20



	<u>Page</u>
4.8.10 Flammability	20
4.8.11 Resistance to Fluids	20
4.8.12 Surface Resistance	20
4.8.13 Abrasion Resistance	20
4.8.14 Soldering	20
4.8.15 Solderability	20
4.8.16 Radiation Resistance	20
4.8.17 Overload Resistance	20
4.8.18 Long-term Ageing Test	20
4.8.19 Anthony and Brown Test	20

### TABLES

1(a) Type Variants	6
1(b) Maximum Ratings	9
A Mandrel Diameters and Loads for Finished Wires	18
B Mandrel Diameters and Loads for Shielded and Jacketed Cables	19
C Mandrel Diameters and Loads for Finished Wires or Cores	19
2 Electrical Measurements at Room Temperature	21

### FIGURES

1 Parameter Derating Information	9
2 Physical Characteristics	10

### APPENDICES (Applicable to specific Manufacturers only)

'A' Agreed Deviations for Tyco Electronics (UK) Ltd. (G.B.)	22
-------------------------------------------------------------	----

**1. GENERAL****1.1 SCOPE**

This specification details the ratings, physical and electrical characteristics, test and inspection data for Extruded Cross-linked Modified ETFE Insulated Wires and Cables, Lightweight, Spiral Shielded, (With and Without Drain Wires), Low Frequency, 600V, -100 to +200 °C.

It shall be read in conjunction with ESA/SCC Generic Specification No. 3901, the requirements of which are supplemented herein.

**1.2 TYPE VARIANTS**

Variants of the basic types of wires and cables specified herein which are also covered by this specification, are listed in Table 1(a).

**1.3 MAXIMUM RATINGS**

The maximum ratings, applicable to the finished wires and cables specified herein, which shall not be exceeded at any time during use or storage in controlled space environment, are scheduled in Table 1(b).

**1.4 PARAMETER DERATING INFORMATION**

The derating information applicable to the finished wires and cables specified herein is as follows:

- The maximum current for each wire used in a bundle shall be:-

$$I_{Bmax} = I_{max} \times \frac{29 - n}{28} \quad (\text{for } 1 < n < 15)$$

$$I_{Bmax} = \frac{I_{max}}{2} \quad (\text{for } n > 15)$$

where n = number of wires in the bundle;

- The temperature derating information is shown in Figure 1 with maximum current  $I_{max}$  for a single wire.
- The derating factors contained herein indicate maximum stress values and do not preclude further derating.

**1.5 PHYSICAL CHARACTERISTICS**

The physical characteristics of the finished wires and cables specified herein are shown in Figure 2.

**1.6 FUNCTIONAL DIAGRAM**

Not applicable.



**SCC**

ESA/SCC Detail Specification

No. 3901/022

PAGE 6

ISSUE 2

**TABLE 1(a) - TYPE VARIANTS**

VARIANT No.	SHIELDED	DRAIN WIRE	No. OF CORES	WIRE SIZE ISO/ (AWG)	STRANDING No. OF STRANDS x DIAMETER (mm)	CONDUCTOR CHARACTERISTICS			SHIELD STRAND Ø (mm)	CORE MAX Ø (mm)	FINISHED WIRE OR CABLE CHARACTERISTICS	
						MAX Ø (mm)	NOM SECT. (mm <sup>2</sup> )	MAX OHMIC RESISTANCE (Ω/km)			MAX Ø (mm)	MAX WEIGHT (kg/km)
01	X		1	-(28)	7 X 0.12 (2)	0.38	0.08	248.9	0.08	0.63	1.22	3.56
02	X		1	001/(26)	19 X 0.10 (1) (2)	0.50	0.15	150	0.08	0.75	1.34	4.46
03	X		1	002/(24)	19 X 0.12 (1) (2)	0.62	0.21	106	0.08	0.87	1.46	5.60
04	X		1	004/(22)	19 X 0.15 (1)	0.76	0.34	58	0.08	1.01	1.60	7.49
05	X		1	006/(20)	19 X 0.20 (1)	1.01	0.60	32.3	0.08	1.26	1.86	10.50
06	X		1	010	19 X 0.25 (1)	1.26	0.93	20.3	0.08	1.56	2.14	14.87
07	X		2	-(28)	7 X 0.12 (2)	0.38	0.08	256.4	0.08	0.63	1.80	6.04
08	X		2	001/(26)	19 X 0.10 (1) (2)	0.50	0.15	154.5	0.08	0.75	2.05	7.66
09	X		2	002/(24)	19 X 0.12 (1) (2)	0.62	0.21	109.2	0.08	0.87	2.30	9.56
10	X		2	004/(22)	19 X 0.15 (1)	0.76	0.34	59.8	0.08	1.01	2.58	13.55
11	X		2	006/(20)	19 X 0.20 (1)	1.01	0.60	33.3	0.08	1.26	3.10	20.18
12	X		2	010	19 X 0.25 (1)	1.26	0.93	20.9	0.10	1.56	3.66	28.50
13	X		3	-(28)	7 X 0.12 (2)	0.38	0.08	256.4	0.08	0.63	1.96	9.05
14	X		3	001/(26)	19 X 0.10 (1) (2)	0.50	0.15	154.5	0.08	0.75	2.23	12.13
15	X		3	002/(24)	19 X 0.12 (1) (2)	0.62	0.21	109.2	0.08	0.87	2.51	15.24
16	X		3	004/(22)	19 X 0.15 (1)	0.76	0.34	59.8	0.08	1.01	2.82	20.56
17	X		3	006/(20)	19 X 0.20 (1)	1.01	0.60	33.3	0.10	1.26	3.39	30.40
18	X		3	010	19 X 0.25 (1)	1.26	0.93	20.9	0.10	1.56	4.01	43.87
19	X		4	-(28)	7 X 0.12 (2)	0.38	0.08	256.4	0.08	0.63	2.64	11.17
20	X		4	001/(26)	19 X 0.10 (1) (2)	0.50	0.15	154.5	0.08	0.75	2.71	15.37
21	X		4	002/(24)	19 X 0.12 (1) (2)	0.62	0.21	109.2	0.08	0.87	3.17	19.65
22	X		4	004/(22)	19 X 0.15 (1)	0.76	0.34	59.8	0.08	1.01	3.75	26.53
23	X		4	006/(20)	19 X 0.20 (1)	1.01	0.60	33.3	0.10	1.26	4.38	41.47
24	X		4	010	19 X 0.25 (1)	1.26	0.93	20.9	0.10	1.56	5.03	61.17

**NOTES:** See Page 8.



ESA/SCC Detail Specification

No. 3901/022

PAGE 7

ISSUE 2

**TABLE 1(a) - TYPE VARIANTS (CONTINUED)**

VARIANT No.	SHIELDED	DRAIN WIRE	No. OF CORES	WIRE SIZE ISO/ (AWG)	STRANDING No. OF STRANDS x DIAMETER (mm)	CONDUCTOR CHARACTERISTICS			SHIELD STRAND Ø (mm)	CORE MAX Ø (mm)	FINISHED WIRE OR CABLE CHARACTERISTICS	
						MAX Ø (mm)	NOM SECT. (mm <sup>2</sup> )	MAX OHMIC RESISTANCE (Ω/km)			MAX Ø (mm)	MAX WEIGHT (kg/km)
25	X		1	012/(16)	19 x 0.30 (1)	1.55	1.20	14.8	0.08	1.90	2.39	19.15
26	X		1	020	37 x 0.25 (1)	1.82	2.00	10.2	0.08	2.29	2.85	26.30
27	X		1	030/(12)	37 x 0.32 (1)	2.28	3.00	6.5	0.10	2.74	3.38	39.59
28	X		2	012/(16)	19 x 0.30 (1)	1.55	1.20	15.2	0.10	1.90	4.26	38.23
29	X		2	020	37 x 0.25 (1)	1.82	2.00	10.5	0.10	2.29	5.19	52.95
30	X		2	030/(12)	37 x 0.32 (1)	2.28	3.00	6.7	0.10	2.74	6.14	77.39
31	X		3	012/(16)	19 x 0.30 (1)	1.55	1.20	15.2	0.10	1.90	4.55	54.59
32	X		3	020	37 x 0.25 (1)	1.82	2.00	10.5	0.10	2.29	5.55	76.11
33	X		3	030/(12)	37 x 0.32 (1)	2.28	3.00	6.7	0.10	2.74	6.58	112.36
34	X		4	012/(16)	19 x 0.30 (1)	1.55	1.20	15.2	0.10	1.90	5.01	70.72
35	X		4	020	37 x 0.25 (1)	1.82	2.00	10.5	0.10	2.29	6.12	96.90
36	X		4	030/(12)	37 x 0.32 (1)	2.28	3.00	6.7	0.10	2.74	7.28	146.71
37	X	X	1	-(28)	7 x 0.12 (2)	0.38	0.08	248.9	0.08	0.63	1.58	5.13
38	X	X	1	001/(26)	19 x 0.10 (1) (2)	0.50	0.15	150	0.08	0.75	1.82	7.02
39	X	X	1	002/(24)	19 x 0.12 (1) (2)	0.62	0.21	106	0.08	0.87	2.04	8.95
40	X	X	1	004/(22)	19 x 0.15 (1)	0.76	0.34	58	0.08	1.01	2.34	12.28
41	X	X	1	006/(20)	19 x 0.20 (1)	1.01	0.60	32.3	0.08	1.26	2.85	18.68
42	X	X	1	010	19 x 0.25 (1)	1.26	0.93	20.3	0.10	1.56	3.49	28.20
43	X	X	1	012/(16)	19 x 0.30 (2)	1.55	1.20	14.8	0.10	1.90	3.99	37.01
44	X	X	1	020	37 x 0.25 (1)	1.82	2.00	10.2	0.10	2.29	4.71	50.03
45	X	X	1	030/(12)	37 x 0.32 (1)	2.28	3.00	6.51	0.10	2.74	5.66	74.17
46	X	X	2	-(28)	7 x 0.12 (2)	0.38	0.08	256.4	0.08	0.63	1.82	7.11
47	X	X	2	001/(26)	19 x 0.10 (1) (2)	0.50	0.15	154.5	0.08	0.75	2.06	9.80
48	X	X	2	002/(24)	19 x 0.12 (1) (2)	0.62	0.21	109.2	0.08	0.87	2.28	12.43

NOTES: See Page 8.



**SEC**

ESA/SCC Detail Specification

No. 3901/022

PAGE 8

ISSUE 2

**TABLE 1(a) - TYPE VARIANTS (CONTINUED)**

VARIANT No.	SHIELDED	DRAIN WIRE	No. OF CORES	WIRE SIZE ISO/ (AWG)	STRANDING No. OF STRANDS x DIAMETER (mm)	CONDUCTOR CHARACTERISTICS			SHIELD STRAND Ø (mm)	CORE MAX Ø (mm)	FINISHED WIRE OR CABLE CHARACTERISTICS	
						MAX Ø (mm)	NOM SECT. (mm <sup>2</sup> )	MAX OHMIC RESISTANCE (Ω/km)			MAX Ø (mm)	MAX WEIGHT (kg/km)
49	X	X	2	004/(22)	19 x 0.15 (1)	0.76	0.34	59.8	0.08	1.01	2.58	17.06
50	X	X	2	006/(20)	19 x 0.20 (1)	1.01	0.60	33.3	0.08	1.26	3.07	26.00
51	X	X	2	010	19 x 0.25 (1)	1.26	0.93	20.9	0.10	1.56	3.78	39.68
52	X	X	2	012/(16)	19 x 0.30 (1)	1.55	1.20	15.2	0.10	1.90	4.26	52.08
53	X	X	2	020	37 x 0.25 (1)	1.82	2.00	10.5	0.10	2.29	5.19	71.87
54	X	X	2	030/(12)	37 x 0.32 (1)	2.28	3.00	6.7	0.10	2.74	6.14	106.84
55	X	X	3	- / (28)	7 x 0.12 (2)	0.38	0.08	256.4	0.08	0.63	1.92	8.60
56	X	X	3	001/(26)	19 x 0.10 (1) (2)	0.50	0.15	154.5	0.08	0.75	2.18	12.10
57	X	X	3	002/(24)	19 x 0.12 (1) (2)	0.62	0.21	109.2	0.08	0.87	2.42	15.57
58	X	X	3	004/(22)	19 x 0.15 (1)	0.76	0.34	59.8	0.08	1.01	2.74	21.64
59	X	X	3	006/(20)	19 x 0.20 (1)	1.01	0.60	33.3	0.10	1.26	3.32	34.79
60	X	X	3	010	19 x 0.25 (1)	1.26	0.93	20.9	0.10	1.56	4.03	51.10
61	X	X	3	012/(16)	19 x 0.30 (1)	1.55	1.20	15.2	0.10	1.90	4.55	67.53
62	X	X	3	020	37 x 0.25 (1)	1.82	2.00	10.5	0.10	2.29	5.55	93.52
63	X	X	3	030/(12)	37 x 0.32 (1)	2.28	3.00	6.7	0.10	2.74	6.58	139.79
64	X	X	4	- / (28)	7 x 0.12 (2)	0.38	0.08	256.4	0.08	0.63	2.20	10.73
65	X	X	4	001/(26)	19 x 0.10 (1) (2)	0.50	0.15	154.5	0.08	0.75	2.51	15.06
66	X	X	4	002/(24)	19 x 0.12 (1) (2)	0.62	0.21	109.2	0.08	0.87	2.80	19.48
67	X	X	4	004/(22)	19 x 0.15 (1)	0.76	0.34	59.8	0.08	1.01	3.18	27.06
68	X	X	4	006/(20)	19 x 0.20 (1)	1.01	0.60	33.3	0.10	1.26	3.87	43.37
69	X	X	4	010	19 x 0.25 (1)	1.26	0.93	20.9	0.10	1.56	4.73	64.16
70	X	X	4	012/(16)	19 x 0.30 (1)	1.55	1.20	15.2	0.10	1.90	5.36	84.93
71	X	X	4	020	37 x 0.25 (1)	1.82	2.00	10.5	0.10	2.29	6.31	116.63
72	X	X	4	030/(12)	37 x 0.32 (1)	2.28	3.00	6.7	0.10	2.74	7.80	176.93

**NOTES**  
 1. In accordance with ISO 2635. AWG sizes are given for reference.  
 2. Copper alloy.





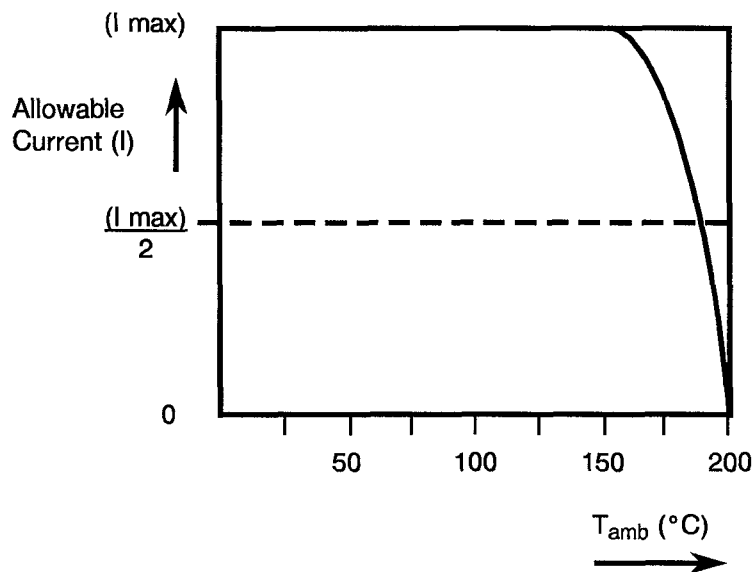
**TABLE 1(b) - MAXIMUM RATINGS**

No.	CHARACTERISTICS	SYMBOL	MAXIMUM RATINGS	UNIT	REMARKS
1	Voltage	$V_p$	600	Vrms	
2	Maximum Current (Note 1)	$I_{max}$	2.0 2.5 3.5 5.0 7.5 10 13 17 23	A	Nom. Sect. (mm <sup>2</sup> ) 0.08 28 0.15 26 0.21 24 0.34 22 0.60 20 0.93 - 1.20 16 2.00 - 3.00 12
3	Operating Temperature Range	$T_{amb}$		°C	
4	Storage Temperature Range	$T_{stg}$		°C	

**NOTES**

- The above specified current will generate a temperature rise of approximately 50°C above ambient temperature in a vacuum environment. Precautions shall be taken to prevent the total temperature of the wire (ambient plus rise) exceeding the continuous operating temperature of the wire.

**FIGURE 1 - PARAMETER DERATING INFORMATION**



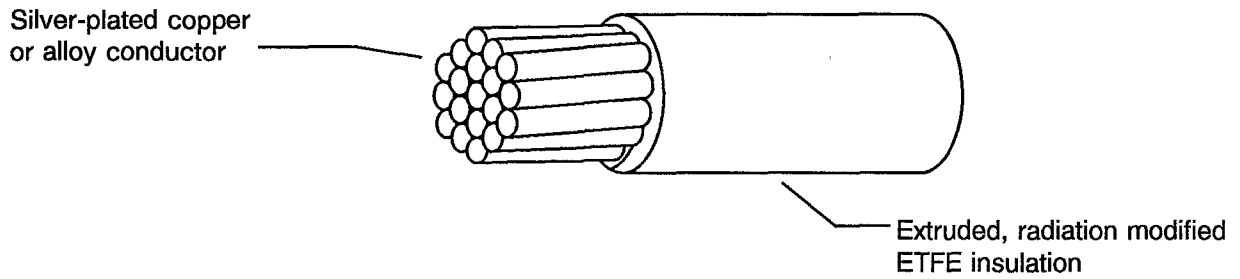
Allowable Current versus Temperature



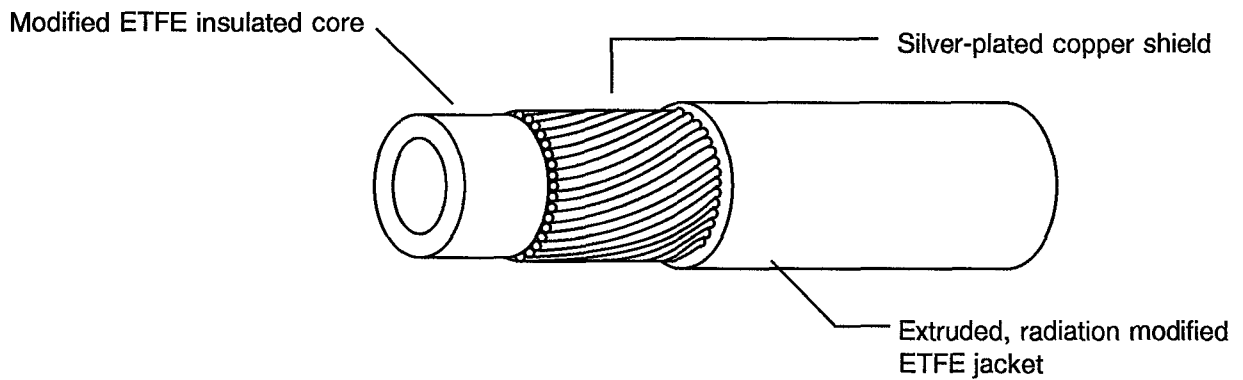
**FIGURE 2 - PHYSICAL CHARACTERISTICS**

Dimensions are given in Table 1(a)

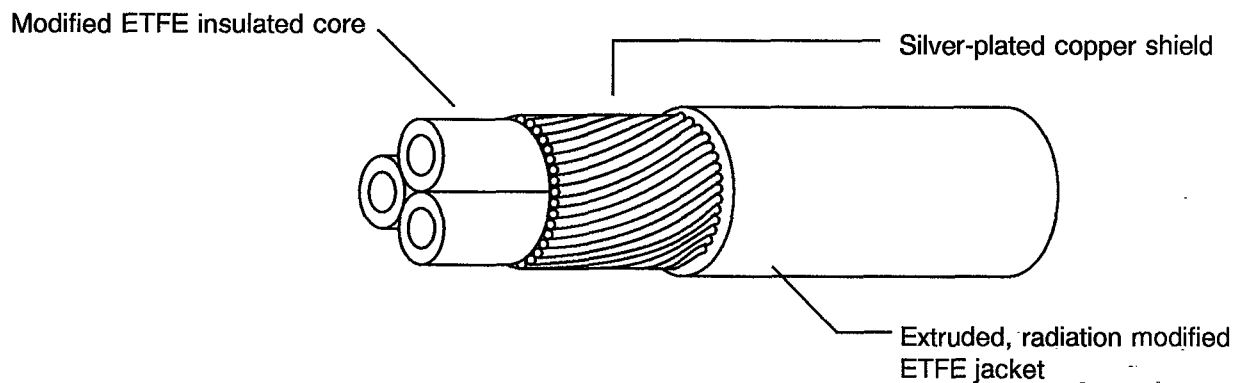
**FIGURE 2(a) - FINISHED WIRES**



**FIGURE 2(b) - SHIELDED AND JACKETED CABLES**



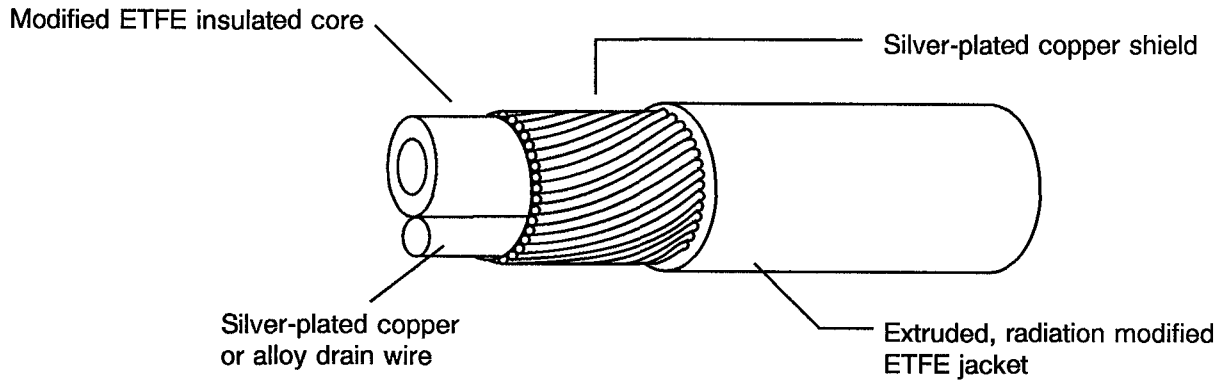
**FIGURE 2(c) - SHIELDED AND JACKETED CABLES**



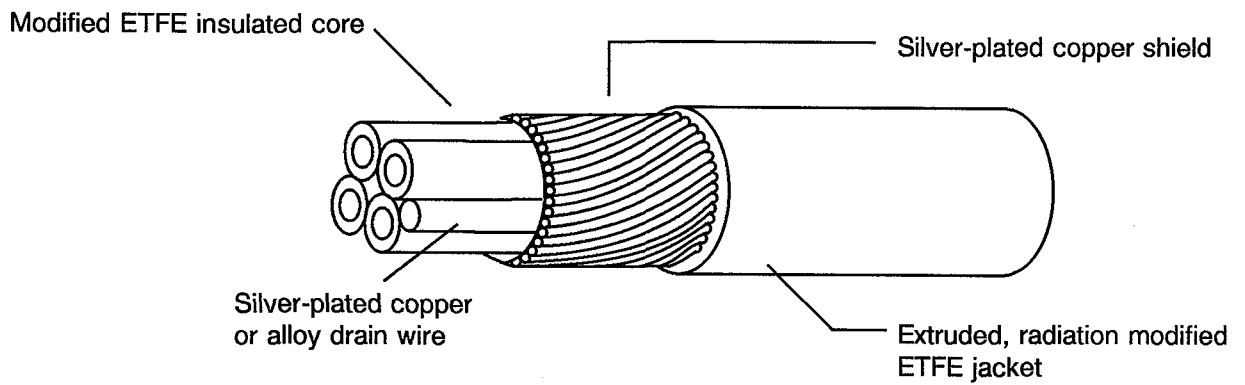


**FIGURE 2 - PHYSICAL CHARACTERISTICS (CONTINUED)**

**FIGURE 2(d) - SHIELDED AND JACKETED CABLES WITH DRAIN WIRE**



**FIGURE 2(e) - SHIELDED AND JACKETED CABLES WITH DRAIN WIRE**



**2. APPLICABLE DOCUMENTS**

The following documents form part of this specification and shall be read in conjunction with it:-

- (a) ESA/SCC Generic Specification No. 3901, Wires and Cables, Electrical, 600V, Low Frequency.
- (b) ASTM-B298-74, Silver-coated Soft or Annealed Copper Wires.
- (c) MIL-F-14256, Flux, Soldering, Liquid (Rosin Base).
- (d) ISO 2635, Conductors for General Purpose Aircraft Electrical Cables and Aerospace Applications - Dimensions and Characteristics.

**3. TERMS, DEFINITIONS, ABBREVIATIONS, SYMBOLS AND UNITS**

For the purpose of this specification, the terms, definitions, abbreviations, symbols and units specified in ESA/SCC Basic Specification No. 21300 and ESA/SCC Generic Specification No. 3901 shall apply.

**4. REQUIREMENTS****4.1 GENERAL**

The complete requirements for procurement of the finished wires and cables specified herein are stated in this specification and ESA/SCC Generic Specification No. 3901. Deviations from the Generic Specification, applicable to this specification only, are listed in Para 4.2.

Deviations from the applicable Generic Specification and this Detail Specification, formally agreed with specific Manufacturers on the basis that the alternative requirements are equivalent to the ESA/SCC requirements and do not affect the components' reliability, are listed in the Appendices attached to this specification.

**4.2 DEVIATIONS FROM GENERIC SPECIFICATION****4.2.1 Deviations from Special In-process Controls**

None.

**4.2.2 Deviations from Final Production Tests (Chart II)**

None.

**4.2.3 Deviations from Burn-in and Electrical Measurements (Chart III)**

Not applicable.

**4.2.4 Deviations from Qualification Tests (Chart IV)**

None.

**4.2.5 Deviations from Lot Acceptance Tests (Chart V)**

None.

**4.3 MECHANICAL REQUIREMENTS****4.3.1 Dimension Check**

The dimensions of the finished wires and cables specified herein shall be checked; they shall conform to those shown in Table 1(a), Figure 2 and Para 4.4 of this specification (see below for the list of parameters to be checked).

**LIST OF PARAMETERS TO BE CHECKED**

PARAMETER	TABLE 1(a)	FIGURE 2	PARA 4.4
<b><u>COMPOSITION</u></b>			
Number of conductors	X		
Gauge	X		
Shielding	X		
Jacket		X	
<b><u>CONDUCTOR</u></b>			
Nature			X
Outer diameter	X		
Number of strands	X		
Strand diameter	X		
Length of lay			X
Silver thickness			X
<b><u>INSULATION</u></b>			
Composition		X	X
Thickness			X
Concentricity			X
Outer diameter	X		
Core identification			X
Colour			X
<b><u>SHIELDING</u></b>			
Number of strands	X		
Type of shielding			X
Strand diameter	X		
Shield strand adhesion			X
Shielding lay			X
Shield coverage			X
<b><u>DRAIN WIRE</u></b>			
Nature		X	X
Outer diameter	X		
Number of strands	X		
Strand diameter	X		
Length of lay			X
Silver thickness			X
<b><u>JACKET</u></b>			
Composition		X	X
Thickness			X
Concentricity			X
Outer diameter	X		
Colour			X

**4.3.2 Weight**

The maximum weight of the finished wires and cables specified herein shall be as specified in Table 1(a).



#### 4.4 MATERIALS AND FINISHES

The materials and finishes shall be as specified herein. Where a definite material is not specified, a material which will enable the wires and cables specified herein to meet the performance requirements of this specification shall be used. Acceptance or approval of any constituent material does not guarantee acceptance of the finished product.

##### 4.4.1 Conductor

###### 4.4.1.1 Material Characteristics

All strands used in the manufacture of the conductors shall be silver-plated, high strength copper alloy for sizes 0.08 to 0.21mm<sup>2</sup> inclusive and silver-plated, soft or annealed, high conductivity copper for sizes 0.34 to 0.93mm<sup>2</sup> inclusive. The silver-coating on all strands shall be 2.0µm minimum.

On all copper conductors, any strand shall show a 10% minimum elongation at break and a 220N/mm<sup>2</sup> minimum tensile strength. On all high-strength alloy conductors, any strand shall show a 6% minimum elongation at break and a 350N/mm<sup>2</sup> minimum tensile strength.

The test shall be performed on single strands from the complete conductor, except for copper alloy, where the inner 7 strands shall be tested together to eliminate variance.

For determination of the conductor resistance at +20°C as mentioned in Para. 9.5 of ESA/SCC Generic Specification No. 3901, the 'α' coefficient for copper alloy is 0.0035.

###### 4.4.1.2 Stranding

The conductors shall be constructed of concentrically laid strands to produce a smooth and uniform conductor of circular cross-section and free from any high strands or other surface irregularities.

The length of the left-hand lay of the external layer shall not be less than 8, nor more than 16, times the maximum conductor diameter specified in Table 1(a).

###### 4.4.1.3 Silver-Coating Characteristics

###### (a) Continuity

The silver-coating of the conductor strands shall be continuous. It shall not exhibit visible black spots after testing in accordance with the methods outlined in ASTM-B298-74. The test shall be performed on 3 specimens taken before applying the insulation.

###### (b) Adhesion

The silver-coating shall adhere firmly to the surface of the copper and not exhibit visible detachment when tested in accordance with ASTM-B298-74. This test shall be performed on 3 specimens taken before application of the insulation.

##### 4.4.2 Insulation

###### 4.4.2.1 Material

The insulating material shall be a flame-retarded radiation cross-linked ethylene-tetrafluoroethylene copolymer with additives necessary for processing, performance and colour identification.



#### 4.4.2.2 Construction

The wire insulation shall consist of a single wall extrusion of polymer directly onto the conductor. The insulation shall have an even wall thickness and shall be concentric with the conductor, having a concentricity value (% ratio of minimum to maximum wall thickness) of 70% minimum.

#### 4.4.2.3 Insulation colour

The insulation shall be extruded in a range of 11 colours as identified in Para. 4.5.3.

### 4.4.3 Assembly

#### 4.4.3.1 Construction

A multicore cable shall be constructed by assembling the cores in a left-hand concentric lay. The length of lay shall not be less than 10, nor more than 16, times the maximum multicore assembly diameter as detailed in Table 1(a). The spiral shield shall have a right - hand lay.

### 4.4.4 Shield

#### 4.4.4.1 Material

The shield shall be constructed from silver-coated, soft or annealed high-conductivity copper. Any strand shall show a 10% minimum elongation at break.

#### 4.4.4.2 Construction

The shield shall be closely, helically woven around the strands and shall provide not less than 92% coverage, 'K' being calculated by the following formula:-

$$K = \frac{n \cdot d \cdot \sqrt{(L^2 + P^2)}}{P \cdot L}$$

where:-

- K = % coverage,  
n = total number of shield strands,  
d = mean shield strand diameter,  
L = apparent shielding lay,  
P = outside perimeter of the shielded cable,

where:-

- P =  $\pi(D + d)$  - single core cable,  
P =  $\pi(D + d) + xD$  - multicore cable.

where:-

- D = mean diameter of core insulation,

#### **N.B.**

The shield may exhibit an occasional gap between strands provided that:

- the coverage meets the required value.
- the gap width and gap length are no more than 0.5mm and 50mm respectively.

#### 4.4.4.3 Silver-Coating Characteristics

The silver-coating characteristics of the shield wires shall conform to those of the conductor as specified in Para. 4.4.1.3.

### 4.4.5 Drain Wire

Material, construction, stranding and size of the drain shall be exactly the same as the conductor of the insulated core or cores. It shall be positioned underneath the served, spiral wire shield.



4.4.6 Jacket

The jacket material shall be an extruded flame-retarded radiation cross-linked ethylene-tetrafluoroethylene copolymer with additives necessary for processing, performance and colour identification.

The jacket shall have an even wall thickness of 0.125mm minimum. The jacket shall be extruded in a range of 11 colours as identified in Para. 4.5.3.

4.5 MARKING

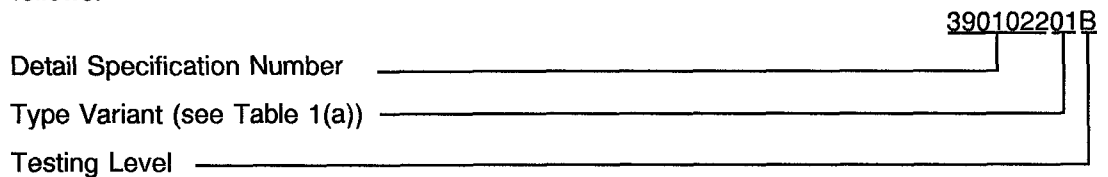
4.5.1 General

The marking of all spools of finished wires and cables delivered to this specification shall be in accordance with the requirements of ESA/SCC Basic Specification No. 21700. Each spool shall be marked in respect of:-

- (a) The SCC Component Number.
- (b) Characteristics.
- (c) Traceability Information.
- (d) Additional Marking.

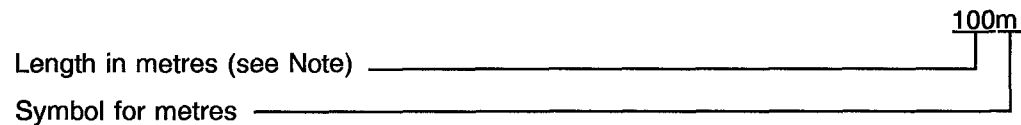
4.5.2 The SCC Component Number

Each spool shall bear the SCC Component Number which shall be constituted and marked as follows:-



4.5.3 Characteristics

The characteristics shall show the length(s) of finished wire or cable wound on each spool and the colours used for conductor insulation and jacket. The length shall be marked as follows:-

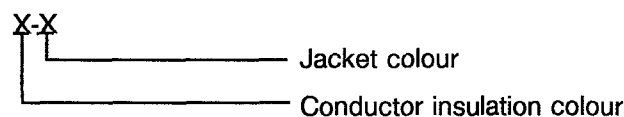


**NOTES**

1. Whenever the length is less than 100 metres, insert a zero in the first block (example: 075m). If more than one length of finished wire or cable is wound on a spool, the characteristics of each length shall be marked as above.

The colours used for conductor insulation and jacket shall be marked as follows:

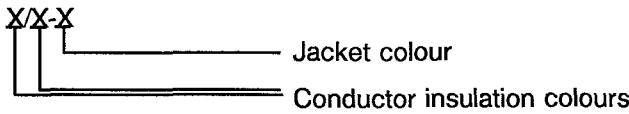
Single Conductor (Variants 01 to 06, 25 to 27 and 37 to 45)



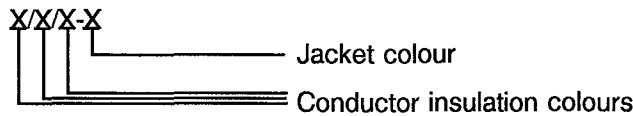




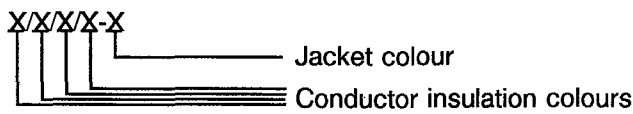
Two Conductors (Variants 07 to 12, 28 to 30 and 46 to 54)



Three Conductors (Variants 13 to 18, 31 to 33 and 55 to 63)



Four Conductors (Variants 19 to 24, 34 to 36 and 64 to 72)



The following codes shall be used for Conductor Insulation and Jacket colours:

- |            |            |           |
|------------|------------|-----------|
| 0 = Black  | 4 = Yellow | 8 = Grey  |
| 1 = Brown  | 5 = Green  | 9 = White |
| 2 = Red    | 6 = Blue   | 2L = Pink |
| 3 = Orange | 7 = Violet |           |

For example, the marking "0/2-9" indicates that one conductor is black, the other is red, and the jacket is white.

If no colour coding is specified, the wires and cables shall be delivered with white conductor insulation and jackets.

4.5.4 Traceability Information

Each spool shall be marked in respect of traceability information in accordance with the requirements of ESA/SCC Basic Specification No. 21700.

4.5.5 Additional Marking

Each spool shall bear the cable Manufacturer's Quality Control Inspector's Stamp.

4.6 ELECTRICAL MEASUREMENTS

4.6.1 Electrical Measurements at Room Temperature

The parameters to be measured at room temperature are scheduled in Table 2. The measurements shall be performed at  $T_{amb} = +22 \pm 3 \text{ }^\circ\text{C}$ .

4.6.2 Electrical Measurements at High and Low Temperatures

Not applicable.

4.6.3 Circuits for Electrical Measurements

Not applicable.

4.7 BURN-IN TESTS

Not applicable.

**4.8 ENVIRONMENTAL AND ENDURANCE TESTS****4.8.1 Mechanical Properties of Conductor**

As detailed in Paras. 4.4.1.1, 4.4.4 and 4.4.5 of this Specification.

**4.8.2 Accelerated Ageing**

Ageing Temperature  $+230 \pm 5$  °C.

The mandrel diameter and appropriate weight used for accelerated age testing of the finished wires are given in Table A. For shielded cables, a change in the shield's aspect shall not be cause for rejection.

**TABLE A - MANDREL DIAMETERS AND LOADS FOR FINISHED WIRES**

Wire Size (mm <sup>2</sup> )	Mandrel Diameter (mm)	Weight (kg)
0.08	6.5	0.060
0.15	10	0.060
0.21	10	0.115
0.34	13	0.170
0.60	13	0.230
0.93	13	0.230
1.2	20	0.340
2.0	25	0.450
3.0	38	0.680

**4.8.3 Wrap Test at Ambient Temperature**

The mandrel diameters and applied loads for wrap testing of finished wires are given in Table A. The mandrel diameters and applied loads for screened and jacketed cables are given in Table B.

**4.8.4 Voltage Test**

No particular conditions are applicable.

**4.8.5 Shrinkage**

The shrinkage temperature shall be  $+200 \pm 5$  °C

**4.8.6 Blocking**

The blocking temperature shall be  $+200 \pm 5$  °C.

**4.8.7 Cold Bend Test**

The mandrel diameters and loads shall be as specified in Table C.

**TABLE B - MANDREL DIAMETERS AND LOADS FOR SHIELDED  
AND JACKETED CABLES**

CABLE SIZE (mm <sup>2</sup> )	NUMBER OF CORES	MANDREL DIAMETER (mm)	LOAD (kg)
0.08	1	19	0.06
	2	25	0.12
	3	25	0.18
	4	25	0.24
0.15	1	19	0.06
	2	25	0.12
	3	25	0.18
	4	32	0.24
0.21	1	19	0.12
	2	25	0.23
	3	25	0.35
	4	32	0.40
0.34	1	19	0.17
	2	32	0.34
	3	32	0.51
	4	44	0.68
0.60	1	25	0.23
	2	32	0.46
	3	44	0.69
	4	44	0.92
0.93	1	25	0.23
	2	44	0.46
	3	44	0.69
	4	57	0.92
1.2	1	25	0.34
	2	44	0.68
	3	44	1.02
	4	57	1.36
2.0	1	32	0.45
	2	57	0.68
	3	57	1.35
	4	57	1.80
3.0	1	32	0.68
	2	57	1.36
	3	76	2.04
	4	76	2.72

**TABLE C - MANDREL DIAMETERS AND LOADS FOR  
FINISHED WIRES OR CORES**

Wire Size (mm <sup>2</sup> )	Mandrel Diameter (mm)	Weight (kg)
0.08	10.0	0.23
0.15	12.5	0.23
0.21	12.5	0.45
0.34	20.0	0.45
0.60	20.0	0.45
0.93	25.4	0.45
1.2	25.4	0.45
2.0	38.1	1.30
3.0	50.8	1.36

**4.8.8 Cut-through Resistance**

The mean load measured during the required tests shall not be less than the relevant value specified below:-

Wire Size (mm <sup>2</sup> )	0.08	0.15	0.21	0.34	0.60	0.93	1.2	3.0	4.0
Cut-through Load (kg)	2.0	2.5	3.0	4.5	6.0	7.0	8.0	10	10

**4.8.9 Notch Resistance**

The depth of notch shall be one third of the nominal wall thickness.

**4.8.10 Flammability**

No particular conditions are applicable.

**4.8.11 Resistance to Fluids**

No particular conditions are applicable.

**4.8.12 Surface Resistance**

No particular conditions are applicable.

**4.8.13 Abrasion Resistance**

The weight to be applied to the needle is specified below:-

Wire Size (mm <sup>2</sup> )	0.08	0.15	0.21	0.34	0.60	0.93	1.2	2.0	3.0
Scrape Abrasion (kg)	0.2	0.25	0.3	0.5	0.5	0.7	0.7	1.0	1.0

**4.8.14 Soldering**

No particular conditions are applicable.

**4.8.15 Solderability (Applicable to the shield only)**

RMA type flux according to MIL-F-14256 shall be used.

**4.8.16 Radiation Resistance**

No particular conditions are applicable.

**4.8.17 Overload Resistance**

No particular conditions are applicable.

**4.8.18 Long-term Ageing Test**

The long-term ageing temperature shall be +200°C. For shielded cables, a change in the shield's aspect shall not be cause for rejection.

**4.8.19 Anthony and Brown Test**

No particular conditions are applicable.

**ESC**ESA/SCC Detail Specification  
No. 3901/022PAGE 21  
ISSUE 2**TABLE 2 - ELECTRICAL MEASUREMENTS AT ROOM TEMPERATURE**

No.	CHARACTERISTICS	SPEC. AND/OR TEST METHOD	TEST CONDITION	LIMITS	UNIT
1	Conductor Resistance	ESA/SCC No. 3901, Section 9	Para 9.5	Table 1(a)	$\Omega$ /km
2	Spark Test	ESA/SCC No. 3901, Section 9	Para 9.6	Insulation : 3.0 Jacket : 1.5	kV
3	Voltage Test	ESA/SCC No. 3901, Section 9	Para 9.7	Para 9.7	kV
4	Insulation Resistance	ESA/SCC No. 3901, Section 9	Para 9.8	Insulation : 750 Jacket : 300	M $\Omega$ .km
5	Surface Resistance	ESA/SCC No. 3901, Section 9	Para 9.22	: 125	M $\Omega$ .mm

**APPENDIX 'A'**

Page 1 of 1

**AGREED DEVIATIONS FOR TYCO ELECTRONIC (UK) LTD. (GB)**

ITEMS AFFECTED	DESCRIPTION OF DEVIATIONS
Para. 4.2.1	<p>The silver coating thickness on soft annealed copper may be determined by electron microscopy and electromechanical mass removal calculation (Kocur technique). The electron microscope shall have a magnification greater than <math>\times 600</math> and enable measurement of the minimal radial-thickness of a single strand.</p> <p><b><u>N.B.</u></b> The criteria specified in ESA/SCC Generic Specification No. 3901 Para. 5.3.2 remain unchanged.</p>
Para. 4.2.2	<p>"Stripping Capability" may be performed using the test methods specified below:-</p> <p>The stripping of the wire insulation shall be conducted using a mechanical wire stripper with preset precision die blades designed for wires conforming to MIL-W-22759. The following procedure shall be used to assess the wire's strippability:-</p> <ul style="list-style-type: none"><li>(a) The appropriate set of die blades are selected and correctly positioned in the hand held tool.</li><li>(b) The wire is positioned on the appropriately sized die and 25mm of the insulation is stripped.</li></ul> <p>The insulation must strip on the first application of the hand tool without difficulty.</p> <p>Stripping of the cable jacket shall be conducted with a hand held tool to make a shallow notch in the jacket at a distance of 50mm from the cable end. The cable is then gently flexed to propagate the notch through the jacket wall and the excess jacket material is then removed by hand with a firm pulling and twisting action.</p> <p>Alternatively, thermal strippers can be used for both the wire insulation and the cable jacket. In keeping with industrial hygiene practices, avoid inhalation of smoke or fumes arising from the thermal strippers.</p> <p><b><u>N.B.</u></b> The criteria specified in ESA/SCC Generic Specification No. 3901 Para. 9.9 remain unchanged.</p>
Paras. 4.2.4 and 4.2.5	Para. 9.18, Cut-through Resistance: The load may be applied directly to the needle, in which case the rate of loading shall be 6.0kg/minute.