





**european space agency
agence spatiale européenne**

Pages 1 to 17

**RESISTORS, FIXED, THICK FILM,
RADIAL LEADS AND SURFACE MOUNT,
NON-HERMETICALLY SEALED,
BASED ON TYPE RTO HR 50
ESA/SCC Detail Specification No. 4001/024**

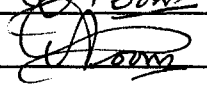

**space components
coordination group**

Issue/Rev.	Date	Approved by	
		SCCG Chairman	ESA Director General or his Deputy
Issue 1	October 2000		
Revision 'A'	January 2001		



DOCUMENTATION CHANGE NOTICE

Rev. Letter	Rev. Date	Reference	CHANGE Item	Approved DCR No.
'A'	Jan. '01	P1. Cover page P2. DCN P5. Para. 3. P6. Table 1(b)	: New definition added : Note 2 amended	None None 23931 23931

**TABLE OF CONTENTS**

	<u>Page</u>
1. <u>GENERAL</u>	5
1.1 Scope	5
1.2 Component Type Variants and Range of Components	5
1.3 Maximum Ratings	5
1.4 Parameter Derating Information	5
1.5 Physical Dimensions	5
1.6 Functional Diagram	5
2. <u>APPLICABLE DOCUMENTS</u>	5
3. <u>TERMS, DEFINITIONS, ABBREVIATIONS, SYMBOLS AND UNITS</u>	5
4. <u>REQUIREMENTS</u>	8
4.1 General	8
4.2 Deviations from Generic Specification	8
4.2.1 Deviations from Special In-process Controls	8
4.2.2 Deviations from Final Production Tests	8
4.2.3 Deviations from Burn-in and Electrical Measurements	8
4.2.4 Deviations from Qualification Tests	8
4.2.5 Deviations from Lot Acceptance Tests	8
4.3 Mechanical Requirements	8
4.3.1 Dimension Check	8
4.3.2 Weight	8
4.3.3 Robustness of Terminations	8
4.4 Materials and Finishes	9
4.4.1 Case	9
4.4.2 Lead Material and Finish	9
4.4.3 Thick Films	9
4.5 Marking	9
4.5.1 General	9
4.5.2 The SCC Component Number	9
4.5.3 Electrical Characteristics and Ratings	10
4.5.4 Traceability Information	11
4.6 Electrical Measurements	11
4.6.1 Electrical Measurements at Room Temperature	11
4.6.2 Electrical Measurements at High and Low Temperatures	11
4.6.3 Circuits for Electrical Measurements	11
4.7 Burn-in Tests	11
4.7.1 Parameter Drift Values	11
4.7.2 Conditions for Burn-in	11
4.7.3 Electrical Circuit for Burn-in	11
4.8 Environmental and Endurance Tests	14
4.8.1 Measurements and Inspections on Completion of Environmental Tests	14
4.8.2 Measurements and Inspections at Intermediate Points during Endurance Tests	14
4.8.3 Measurements and Inspections on Completion of Endurance Tests	14
4.8.4 Conditions for Operating Life Tests	14
4.8.5 Electrical Circuits for Operating Life Tests	14
4.8.6 Conditions for High Temperature Storage Test	14



TABLES

	<u>Page</u>
1(a) Type Variants and Range of Components	6
1(b) Maximum Ratings	6
2 Electrical Measurements at Room Temperature	12
3 Electrical Measurements at High and Low Temperatures	12
4 Parameter Drift Values	12
5(a) Conditions for Burn-in	13
5(b) Conditions for Operating Life Tests	13
6 Measurements and Inspections on Completion of Environmental Tests and at Intermediate Points and on Completion of Endurance Testing	15

FIGURES

1 Parameter Derating Information	7
2 Physical Dimensions	7
3 Functional Diagram	8
4 Circuits for Electrical Measurements	12
5 Electrical Circuit for Burn-in and Operating Life Tests	14

APPENDICES (Applicable to specific Manufacturers only)

None.

**1. GENERAL****1.1 SCOPE**

This specification details the ratings, physical and electrical characteristics, test and inspection data for Resistors, Fixed, Thick Film, Radial Leads and Surface Mount, Non-hermetically Sealed, based on Type RTO HR 50. It shall be read in conjunction with ESA/SCC Generic Specification No. 4001, the requirements of which are supplemented herein.

1.2 COMPONENT TYPE VARIANTS AND RANGE OF COMPONENTS

The component type variants and range of resistors and type variants covered by this specification are given in Table 1(a).

1.3 MAXIMUM RATINGS

The maximum ratings, which shall not be exceeded at any time during use or storage, applicable to the resistors specified herein, are as scheduled in Table 1(b).

1.4 PARAMETER DERATING INFORMATION

The parameter derating information applicable to the resistors specified herein is given in Figure 1.

1.5 PHYSICAL DIMENSIONS

The physical dimensions of the resistors specified herein, are shown in Figure 2.

1.6 FUNCTIONAL DIAGRAM

The functional diagram for the resistors specified herein, is shown in Figure 3.

2. APPLICABLE DOCUMENTS

The following documents form part of this specification and shall be read in conjunction with it:-

- (a) ESA/SCC Generic Specification No. 4001, Resistors, Fixed, Film.

3. TERMS, DEFINITIONS, ABBREVIATIONS, SYMBOLS AND UNITS

For the purpose of this specification, the terms, definitions, abbreviations, symbols and units specified in ESA/SCC Basic Specification No. 21300 shall apply. In addition, the following symbols are used:-

P_H	=	Rated dissipation onto a heatsink.
$R_{TH(HS)}$	=	Thermal Resistance of the heatsink.
$R_{TH(S-MF)}$	=	Thermal Resistance (Substrate to Metal Frame).
TC	=	Temperature Coefficient.
V_T	=	Test Voltage.
$T_{(HS)}$	=	Heatsink temperature.



TABLE 1(a) - TYPE VARIANTS AND RANGE OF COMPONENTS

(1) Variant	(2) Resistance Range (Note 1)		(3) Tolerance (± %)	(4) Value Series	(5) TC (10 ⁻⁶ /°C)	(6) Terminations
	MIN. (Ω)	MAX. (MΩ)				
01	0.046	1.0M	R ≤ 0.5Ω = 5.0 R > 0.5Ω = 1.0 or 5.0	E96	R ≤ 0.1Ω = 500 0.1Ω < R ≤ 1.0Ω = 300 R > 1.0Ω = 150 (Note 2)	Leaded
02	0.046	1.0M		E96		Surface Mount

NOTES

1. Critical resistance = 2.25kΩ.
2. R ≤ 1.0Ω for information only.

TABLE 1(b) - MAXIMUM RATINGS

No.	Characteristics	Symbol	Limits	Unit	Remarks
1	Thermal Resistance (Substrate to Metal Frame)	R _{TH(S-MF)}	3.25	°C/W	-
2	Rated Dissipation	P _n	2.25	W	Note 1
3	Rated Dissipation onto a Heatsink	P _H	$\frac{155 - T_{amb}}{3.25 + R_{TH(HS)}}$	W	Note 2
4	Limiting Element Voltage	U _L	300	V	-
5	Rated Voltage	U _R	$\sqrt{P_N \times R}$ or 300V	V	Note 3
6	Insulation Voltage	U _i	2 000	V _{ms}	-
7	Operating Temperature Range	T _{OP}	-55 to +155	°C	T _{amb}
8	Storage Temperature Range	T _{stg}	-55 to +155	°C	-
9	Soldering Temperature	T _{sol}	+235	°C	Note 4

NOTES

1. At T_{amb} ≤ +25°C in free air. For derating at T_{amb} > +25°C, see Figure 1(a).
2. At T_{amb} ≤ +25°C and mounted onto an infinite heatsink. With R_{TH(HS)} = 0, P_H = 40W. For derating at T_(HS) > +25°C, see Figure 1(b).
3. Whichever is smaller.
4. Duration 2 seconds maximum for soldering operations that include the complete connections.



FIGURE 1 - PARAMETER DERATING INFORMATION

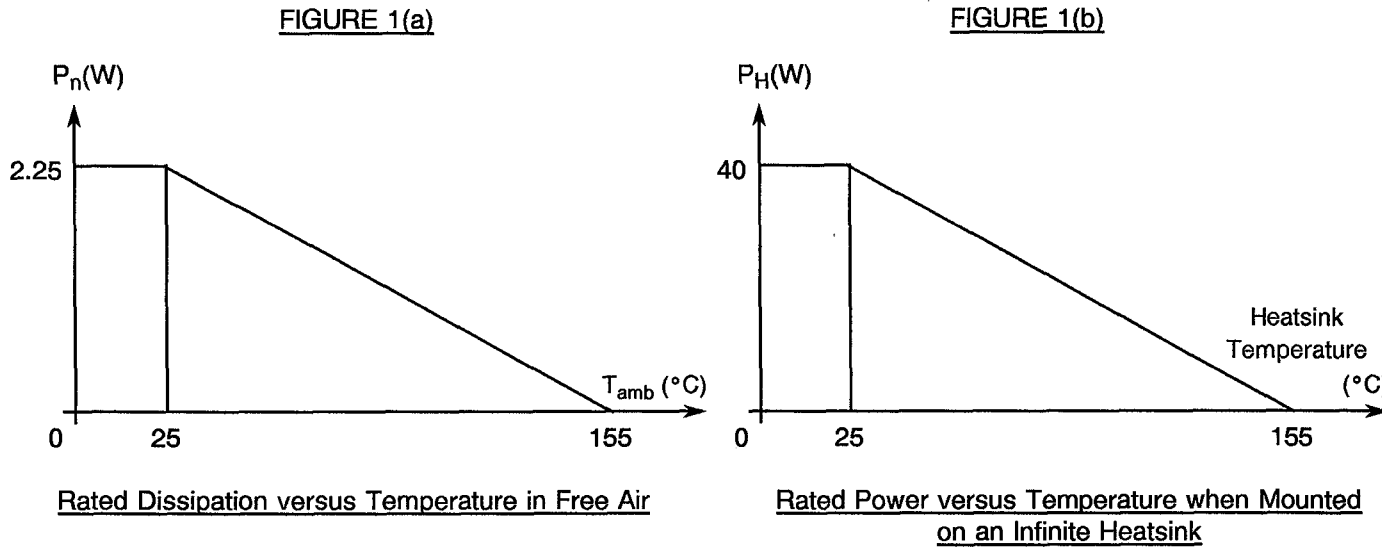
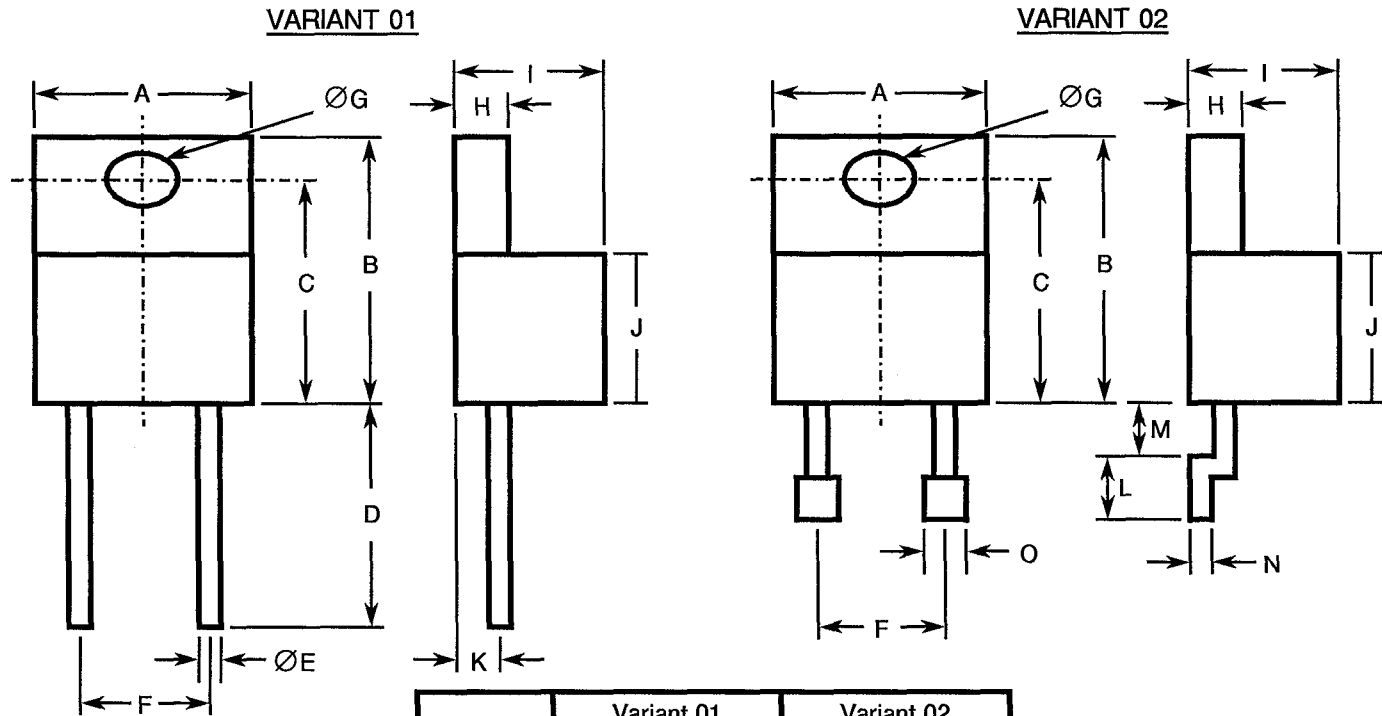
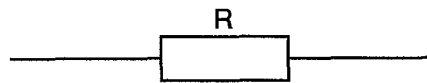

FIGURE 2 - PHYSICAL DIMENSIONS



Symbol	Variant 01		Variant 02	
	Min.	Max.	Min.	Max.
A	9.7	10.5	9.7	10.5
B	14.6	15.4	14.6	15.4
C	12.1	12.9	12.1	12.9
D	13.3	14.1	-	-
ØE	0.6	1.0	-	-
F	4.98	5.18	4.98	5.18
ØG	3.5	3.7	3.5	3.7
H	1.1	1.5	1.1	1.5
I	4.4	4.9	4.4	4.9
J	8.4	9.2	8.4	9.2
K	2.3	2.7	-	-
L	-	-	2.5	3.5
M	-	-	1.5	2.5
N	-	-	0.2	0.4
O	-	-	1.3	2.3

**FIGURE 3 - FUNCTIONAL DIAGRAM**

4. **REQUIREMENTS**

4.1 **GENERAL**

The complete requirements for procurement of the resistors specified herein shall be as stated in this specification and ESA/SCC Generic Specification No. 4001. Deviations from the Generic Specification, applicable to this specification only, are listed in Para. 4.2.

Deviations from the applicable Generic Specification and this Detail Specification, formally agreed with specific Manufacturers on the basis that the alternative requirements are equivalent to the ESA/SCC requirements and do not affect the components' reliability, are listed in the appendices attached to this specification.

4.2 **DEVIATIONS FROM GENERIC SPECIFICATION**

4.2.1 **Deviations from Special In-process Controls**

None.

4.2.2 **Deviations from Final Production Tests (Chart II)**

(a) Para. 9.1, Overload: The test conditions shall be:-

Voltage: $\sqrt{2P_n \times R_n}$ or $1.5U_L$, whichever is less.

Duration: 5 seconds.

(b) Para. 9.2, Third Harmonic Control: Not applicable.

4.2.3 **Deviations from Burn-in and Electrical Measurements (Chart III)**

(a) Para. 9.3, Seal Test: Not applicable.

4.2.4 **Deviations from Qualification Tests (Chart IV)**

(a) Para. 9.1, Overload: Test Conditions as Para. 4.2.2(a).

(b) Para. 9.10.2.3, Bend Strength of the End Face Plating: Not applicable.

4.2.5 **Deviations from Lot Acceptance Tests (Chart V)**

(a) Para. 9.10.2.3, Bend Strength of the End Face Plating: Not applicable.

4.3 **MECHANICAL REQUIREMENTS**

4.3.1 **Dimension Check**

The dimensions of the resistors specified herein shall be verified in accordance with the requirements set out in Para. 9.4 of ESA/SCC Generic Specification No. 4001 and shall conform to those shown in Figure 2 of this specification.

4.3.2 **Weight**

The maximum weight of the resistors specified herein shall be 3.0 grammes.

4.3.3 **Robustness of Terminations**

The requirements and test conditions for robustness of terminations are specified in Para. 9.10.2 of ESA/SCC Generic Specification No. 4001.



4.4 MATERIALS AND FINISHES

The materials and finishes shall be as specified herein. Where a definite material is not specified, a material which will enable the components specified herein to meet the performance requirements of this specification shall be used. Acceptance or approval of any constituent material does not guarantee acceptance of the finished product.

4.4.1 Case

As a minimum, the resistance element shall be protected by a suitable inorganic coating.

4.4.2 Lead Material and Finish

The lead material shall be Type 'P' with Type '3' finish in accordance with the requirements of ESA/SCC Basic Specification No. 23500.

4.4.3 Thick Films

Thick films shall be uniformly deposited. They shall be free from blisters, thin spots, areas inadequately bonded to the substrate and discoloured spots.

4.5 MARKING

4.5.1 General

The marking of all components delivered to this specification shall be in accordance with the requirements of ESA/SCC Basic Specification No. 21700 and the following paragraphs. When the component is too small to accommodate all of the marking specified, as much as space permits shall be marked and the marking information, in full, shall accompany each component in its primary package.

The information to be marked, and the order of precedence, shall be as follows:-

- (a) The SCC Component Number.
- (b) Electrical Characteristics and Ratings.
- (c) Traceability Information.

4.5.2 The SCC Component Number

Each component shall bear the SCC Component Number which shall be constituted and marked as follows:

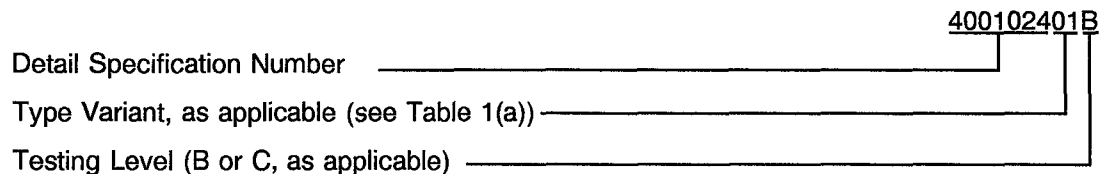



4.5.3 Electrical Characteristics and Ratings

The electrical characteristics and ratings to be marked in the following order of precedence are:-

- (a) Resistance Value.
- (b) Tolerance.
- (c) Temperature Coefficient.

The information shall be constituted and marked as follows:

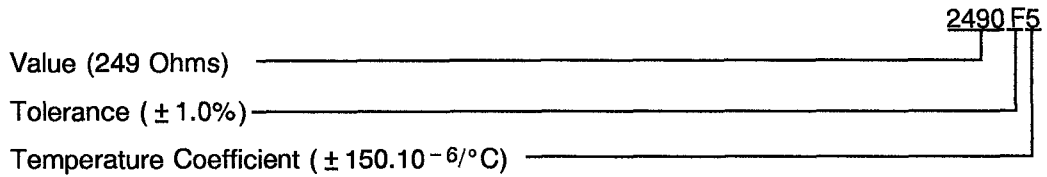

4.5.3.1 Resistance Values

Resistance values shall be expressed by means of the following codes.

The unit quantity for marking shall be in Ohms (Ω).

Numerical Value	Code
0.XXX	RXXX
X.XX	XR.XX
XX.X	XXRX
XXX	XXX0
XXX10 ¹	XXX1
XXX10 ²	XXX2
XXX10 ³	XXX3
XXX10 ⁴	XXX4

For values of 100 Ω and above, the first 3 digits (X) represent significant figures and the last digit specifies the number of zeros to follow.

When values of less than 100 Ω are required, the letter 'R' is used to indicate the decimal point. When the letter is used, all successive digits represent significant figures.

4.5.3.2 Tolerance

The tolerance on resistance values shall be indicated by the code letters specified hereafter.

Tolerance (\pm %)	Code Letter
1.0	F
5.0	J

4.5.3.3 Temperature Coefficient

The temperature coefficient shall be indicated by the numerical codes specified hereafter.

Digit	Temperature Coefficient ($\pm 10^{-6}/^{\circ}\text{C}$)
5	150
6	300
8	500



4.5.4 Traceability Information

Each component shall be marked in respect of traceability information in accordance with the requirements of ESA/SCC Basic Specification No. 21700.

4.6 ELECTRICAL MEASUREMENTS

4.6.1 Electrical Measurements at Room Temperature

The parameters to be measured at room temperature are scheduled in Table 2. The measurements shall be performed at $T_{amb} = +22 \pm 3$ °C.

4.6.2 Electrical Measurements at High and Low Temperatures

The parameters to be measured on a sample basis at high and low temperatures are scheduled in Table 3.

The distribution of the sample shall be as follows:

- 1/3 with the lowest resistance value,
- 1/3 with the highest resistance value,
- 1/3 with the median resistance value or the critical resistance value if procured, of the procured range.

4.6.3 Circuits for Electrical Measurements (Figure 4)

Not applicable.

4.7 BURN-IN TESTS

4.7.1 Parameter Drift Values

The parameter drift values applicable to burn-in are specified in Table 4 of this specification. Unless otherwise stated, measurements shall be performed at $T_{amb} = +22 \pm 3$ °C. The parameter drift values (Δ) applicable to the parameters scheduled, shall not be exceeded. In addition to these drift value requirements, the appropriate limit value specified in Table 2 for a given parameter shall not be exceeded.

4.7.2 Conditions for Burn-in

The requirements for burn-in are specified in Section 7 of ESA/SCC Generic Specification No. 4001. The conditions for burn-in shall be as specified in Table 5(a) of this specification.

Burn-in shall be conducted onto a heatsink of known thermal resistance. Applied voltage shall be set so that:

$$P_H = \frac{\Delta T}{3.25 + R_{TH(HS)}}$$

After 168(+24 - 0) hours, the resistors shall be removed from the chamber and allowed to cool under normal atmospheric conditions for a minimum of 4 hours. They shall then be visually examined. There shall be no evidence of damage and the marking shall still be legible.

4.7.3 Electrical Circuit for Burn-in

The circuit for use in performing the burn-in test is shown in Figure 5 of this specification.



TABLE 2 - ELECTRICAL MEASUREMENTS AT ROOM TEMPERATURE

No.	Characteristics	Symbol	Spec. and/or Test Method	Test Conditions	Tolerance (± %)	Limits		Unit
						Min	Max	
1	Resistance	R _A	Para. 9.5.1	Para. 9.5.1	1.0 5.0	0.99 R _N 0.95 R _N	1.01 R _N 1.05 R _N	Ω

TABLE 3 - ELECTRICAL MEASUREMENTS AT HIGH AND LOW TEMPERATURES

No.	Characteristics	Symbol	Spec. and/or Test Method	Test Conditions (Note 1)	Limits		Unit
					Min.	Max.	
1(a)	Resistance Change between -55(+3-0)°C and +22±3°C	$\frac{\Delta R}{R}$	ESA/SCC Gen. Spec. No. 4001	Para. 9.5.1 R ≤ 1.0Ω R > 1.0Ω	N/A -1.2	N/A +1.2	%
1(b)	Resistance Change between +155(+0-3)°C and +22±3°C	$\frac{\Delta R}{R}$	ESA/SCC Gen. Spec. No. 4001	Para. 9.5.1 R ≤ 1.0Ω R > 1.0Ω	N/A -1.95	N/A +1.95	%

NOTES

- The measurements shall be performed on a sample basis in accordance with Special Inspection Level II, Table IIA, AQL = 0.65% of IEC Publication No. 410 on the total production lot. In addition, see Para. 4.6.2 for distribution of the sample.

FIGURE 4 - CIRCUITS FOR ELECTRICAL MEASUREMENTS

Not applicable.

TABLE 4 - PARAMETER DRIFT VALUES

No.	Characteristics	Symbol	Spec. and/or Test Method	Test Conditions	Change Limits (Δ)	Unit
1	Resistance Change	$\frac{\Delta R_A}{R_A}$	As per Table 2	As per Table 2	±0.05 or (1) ±0.5	Ω %

NOTES

- Whichever is greater, referred to the initial value.

**TABLE 5(a) - CONDITIONS FOR BURN-IN**

No.	Characteristics	Symbol	Condition	Unit
1	Ambient Temperature	T_{amb}	$+ 25 \pm 3$	$^{\circ}\text{C}$
2	Test Voltage	V_T	\sqrt{PR} or 300V, whichever is less	V
3	Test Current	I_T	$\sqrt{\frac{P}{R}}$ or $\frac{300}{R}$, whichever is less	A
4	Rated Power onto Heatsink	P_H	Note 1	W

NOTES

1. Heatsink with a $R_{TH(HS)}$ between 10 and 20°C/W :-

$$P_H = \frac{155 - 25}{3.25 + R_{TH(HS)}}$$

TABLE 5(b) - CONDITIONS FOR OPERATING LIFE TESTS

No.	Characteristics	Symbol	Condition	Unit
1	Ambient Temperature	T_{amb}	$+ 25 \pm 3$	$^{\circ}\text{C}$
2	Test Voltage	V_T	\sqrt{PR} or 300V, whichever is less	V
3	Test Current	I_T	$\sqrt{\frac{P}{R}}$ or $\frac{300}{R}$, whichever is less	A
4	Rated Power onto Heatsink	P_H	Note 1	W

NOTES

1. The resistors shall be mounted onto a heatsink of known thermal resistance. When the voltage applied is \sqrt{PR} ,

$$PR = \frac{\Delta T}{R_{TH(HS)} + 3.25}$$

Where: ΔT = Maximum working temperature between the resistance element and room temperature,
= $155 - 25 = 130^{\circ}\text{C}$.

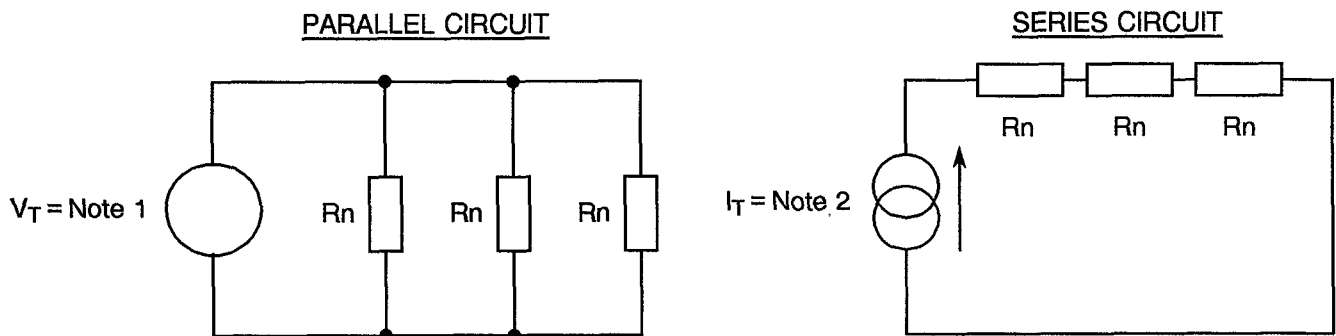
**FIGURE 5 - ELECTRICAL CIRCUIT FOR BURN-IN AND OPERATING LIFE TESTS****NOTES**

1. $V_T = 300\text{V}$ or $\sqrt{P_N R_N}$, whichever is smaller.
2. $I_T = \frac{300\text{V}}{R_N}$ or $\sqrt{P_N R_N}$, whichever is smaller.

4.8 ENVIRONMENTAL AND ENDURANCE TESTS (CHARTS IV AND V OF ESA/SCC GENERIC SPECIFICATION No. 4001)**4.8.1 Measurements and Inspections on Completion of Environmental Tests**

The parameters to be measured and inspections to be performed on completion of environmental tests are scheduled in Table 6. Unless otherwise stated, the measurements shall be performed at $T_{\text{amb}} = +22 \pm 3 \text{ }^\circ\text{C}$.

4.8.2 Measurements and Inspections at Intermediate Points during Endurance Tests

The parameters to be measured and inspections to be performed at intermediate points during endurance tests are as scheduled in Table 6 of this specification. Unless otherwise stated, the measurements shall be performed at $T_{\text{amb}} = +22 \pm 3 \text{ }^\circ\text{C}$.

4.8.3 Measurements and Inspections on Completion of Endurance Tests

The parameters to be measured and inspections to be performed on completion of endurance testing are as scheduled in Table 6 of this specification. Unless otherwise stated, the measurements shall be performed at $T_{\text{amb}} = +22 \pm 3 \text{ }^\circ\text{C}$.

4.8.4 Conditions for Operating Life Tests (Part of Endurance Testing)

The requirements for operating life testing are specified in Section 9 of ESA/SCC Generic Specification No. 4001. The conditions for operating life testing shall be as specified in Table 5(b) of this specification.

4.8.5 Electrical Circuits for Operating Life Tests

Circuits for use in performing the operating life tests are shown in Figure 5 of this specification.

4.8.6 Conditions for High Temperature Storage Test (Part of Endurance Testing)

The requirements for the high temperature storage test are specified in ESA/SCC Generic Specification No. 4001. The conditions for high temperature storage shall be $T_{\text{amb}} = +155(+0-5) \text{ }^\circ\text{C}$.



TABLE 6 - MEASUREMENTS AND INSPECTIONS ON COMPLETION OF ENVIRONMENTAL TESTS AND AT INTERMEDIATE POINTS AND ON COMPLETION OF ENDURANCE TESTING

NO.	ESA/SCC GENERIC SPEC. NO. 4001		MEASUREMENTS AND INSPECTIONS		SYMBOL	LIMITS		UNIT
	ENVIRONMENTAL AND ENDURANCE TESTS (1)	TEST METHOD AND CONDITIONS	IDENTIFICATION	CONDITIONS		MIN.	MAX.	
01	Overload	Para. 9.1 and Paras 4.2.2 and 4.2.4 of this spec.	Initial Measurements Chart IV Resistance Final Measurements Visual Examination Chart II Resistance Chart IV Resistance Change	Table 2 Item 1 After a recovery period of 1-2 hrs No evidence of damage and marking legible Table 2 Item 1 Table 2 Item 1	R _A - R _A ΔR _A /R _A	Record Values - Table 2 Item 1 ± (0.5 + $\frac{0.05\Omega \times 100}{R_n}$)	- - %	
02	Seal Test (Hermetically Sealed only)	Para. 9.3	Not applicable					
03	Insulation Resistance (Insulated only)	Para. 9.6	Final Measurements Insulation Resistance	Para. 9.6.1 of ESA/SCC 4001 (2)	R _i	1000	-	MΩ
04	Temperature Coefficient	Para. 9.7 Procedure I	Temperature Coefficient	Para. 9.5.1 of ESA/SCC 4001	TC	Note 3		10 ⁻⁶ /°C
05	Voltage Proof	Para. 9.8	During Test Visual Examination	1.4 x U _i (4) for 60 ± 5 sec No breakdown or flashover	-	-	-	-
06	Solderability	Para. 9.9 Procedure I	Initial Measurements Resistance Final Measurements Resistance Change	After Drying Table 2 Item 1 24 ± 4 hrs after soldering Table 2 Item 1	R _A ΔR _A /R _A	Record Values ± (0.25 + $\frac{0.05\Omega \times 100}{R_n}$)	- %	
07	Robustness of Terminations	Para. 9.10 and Paras. 4.2.4 and 4.2.5 of this spec.	Initial Measurements Resistance Final Measurements Resistance Change Visual Examination	Table 2 Item 1 Table 2 Item 1 No evidence of damage	R _A ΔR _A /R _A -	Record Values ± (0.25 + $\frac{0.05\Omega \times 100}{R_n}$) -	- -	
08	Resistance to Soldering Heat	Para. 9.11 Procedure I	Initial Measurements Resistance Final Measurements Visual Examination Resistance Change	After Drying Table 2 Item 1 No evidence of damage and marking legible After 24 ± 4 hours Table 2 Item 1	R _A - ΔR _A /R _A	Record Values - ± (0.25 + $\frac{0.05\Omega \times 100}{R_n}$)	- -	Ω %
09	Rapid Change of Temperature	Para. 9.12	Initial Measurements Resistance Final Measurements Visual Examination Resistance Change	Table 2 Item 1 After a recovery period of 1-2 hrs No evidence of damage Table 2 Item 1	R _A - ΔR _A /R _A	Record Values - ± (0.25 + $\frac{0.05\Omega \times 100}{R_n}$)	- -	- %
10	Vibration	Para. 9.13	Initial Measurements Resistance Final Measurements Visual Examination Resistance Change	Table 2 Item 1 No evidence of damage Table 2 Item 1	R _A - ΔR _A /R _A	Record Values - ± (0.25 + $\frac{0.05\Omega \times 100}{R_n}$)	- -	- %

NOTES: See Page 17.



TABLE 6 - MEASUREMENTS AND INSPECTIONS ON COMPLETION OF ENVIRONMENTAL TESTS AND AT INTERMEDIATE POINTS AND ON COMPLETION OF ENDURANCE TESTING (CONT'D)

NO.	ESA/SCC GENERIC SPEC. NO. 4001		MEASUREMENTS AND INSPECTIONS		SYMBOL	LIMITS		UNIT	
	ENVIRONMENTAL AND ENDURANCE TESTS (1)	TEST METHOD AND CONDITIONS	IDENTIFICATION	CONDITIONS		MIN.	MAX.		
11	Climatic Sequence	Para. 9.14 Procedure I	Initial Measurements Resistance	After Drying Table 2 Item 1	R _A	Record Values			
			Final Measurements	Following completion of D.C. load test and after a recovery period of 1-2 hrs	-	-	-	-	
			Visual Examination	No evidence of damage and marking legible	-	-	-	-	
			Insulation Resistance	Para. 9.6.1 of ESA/SCC 4001 (2)	R _i	100	-	MΩ	
			Resistance Change	Table 2 Item 1	ΔR _A /R _A	± (1.0 + $\frac{0.05\Omega \times 100}{R_n}$)		%	
12	Operating Life	Para. 9.15 Chart IV	Initial Measurements Resistance	Table 2 Item 1	R _A	Record Values			
			Intermediate Measurements (1000 hrs)	After a recovery period of 1-2 hrs	-	-	-	-	
			Visual Examination	No evidence of damage	-	-	-	-	
			Resistance Change	Table 2 Item 1	ΔR _A /R _A	± (1.0 + $\frac{0.05\Omega \times 100}{R_n}$)		%	
				Final Measurements (2000 hrs)	After a recovery period of 1-2 hrs	-	-	-	
				Visual Examination	No evidence of damage	-	-	-	
				Resistance Change	Table 2 Item 1	ΔR _A /R _A	± (2.0 + $\frac{0.05\Omega \times 100}{R_n}$)		%
				Insulation Resistance	Para. 9.6.1 of ESA/SCC 4001 (2)	R _i	1000	-	MΩ
		Para. 9.15 Chart V	Initial Measurements Resistance	Table 2 Item 1	R _A	Record Values			
			Final Measurements (1000 hrs)	After a recovery period of 1-2 hrs	-	-	-		
			Visual Examination	No evidence of damage	-	-	-		
			Resistance Change	Table 2 Item 1	ΔR _A /R _A	± (1.0 + $\frac{0.05\Omega \times 100}{R_n}$)		%	
			Insulation Resistance	Para. 9.6.1 of ESA/SCC 4001 (2)	R _i	1000	-	MΩ	
13	High Temperature Storage	Para. 9.16	Initial Measurements Resistance	Table 2 Item 1	R _A	Record Values			
			Intermediate Measurements (1000 hrs)	After a recovery period of 1-2 hrs	-	-	-	-	
			Visual Examination	No evidence of damage	-	-	-	-	
			Resistance Change	Table 2 Item 1	ΔR _A /R _A	± (0.5 + $\frac{0.05\Omega \times 100}{R_n}$)		%	
			Final Measurements (2000 hrs)	After a recovery period of 1-2 hrs	-	-	-		
			Visual Examination	No evidence of damage	-	-	-		
			Resistance Change	Table 2 Item 1	ΔR _A /R _A	± (1.0 + $\frac{0.05\Omega \times 100}{R_n}$)		%	
			Insulation Resistance	Para. 9.6.1 of ESA/SCC 4001 (2)	R _i	1000	-	MΩ	

NOTES: See Page 17.

TABLE 6 - MEASUREMENTS AND INSPECTIONS ON COMPLETION OF ENVIRONMENTAL TESTS AND AT INTERMEDIATE POINTS AND ON COMPLETION OF ENDURANCE TESTING (CONT'D)

NO.	ESA/SCC GENERIC SPEC. NO. 4001		MEASUREMENTS AND INSPECTIONS		SYMBOL	LIMITS		UNIT
	ENVIRONMENTAL AND ENDURANCE TESTS (1)	TEST METHOD AND CONDITIONS	IDENTIFICATION	CONDITIONS		MIN.	MAX.	
14	Permanence of Marking	Para. 9.19	Final Measurements Visual Examination	No corrosion or obliteration of marking	-	-	-	-

NOTES

1. The tests in this Table refer to either Chart IV or V and shall be used as applicable.
2. Test Voltage: $V_T = 100V$.
3. See Column 5 of Table 1(a).
4. For value of U_i , see Item 6 of Table 1(b).