



europaean space agency  
agence spatiale européenne

Pages 1 to 19

**DIODES, SILICON, POWER RECTIFIER,  
FAST RECOVERY,  
BASED ON TYPES 1N5415 THROUGH 1N5420  
ESA/SCC Detail Specification No. 5103/007**



**space components  
coordination group**

Issue/Rev.	Date	Approved by	
		SCCG Chairman	ESA Director General or his Deputy
Issue 1	August 1985	-	-
Revision 'A'	October 1985	-	-
Revision 'B'	July 1993	<i>Pommes</i>	<i>J. Lutz</i>
Revision 'C'	July 1996	<i>Sam Miller</i>	<i>J. Lutz</i>



**DOCUMENTATION CHANGE NOTICE**

Rev. Letter	Rev. Date	Reference	CHANGE Item	Approved DCR No.
'A'	Oct. '85	P1. Cover page P2. DCN P6. Table 1(a)	: Type identification in Column 2 corrected	None None 23222
'B'	July '93	P1. Cover Page P2. DCN P9. Para. 4.2.2 P10. Para. 2 Para. 4.2.3 P15. Table 3	: PIND deviation amended : MIL-STD-1276 deleted : Radiographic Inspection deviation amended : Note 1 deleted, subsequent note renumbered	None None 21043 21025 21049 21047
		This document has been transferred from hardcopy to electronic format. The content is unchanged but minor differences in presentation exist.		
'C'	July '96	P1. Cover page P2. DCN P5. Para. 1.7 P6. Table 1(a) P11. Para. 4.4.2	: Text amended : Lead finish corrected : Text corrected	None None 21083 23822 23822



## TABLE OF CONTENTS

	<u>Page</u>
<b>1. <u>GENERAL</u></b>	<b>5</b>
1.1 Scope	5
1.2 Component Type Variants	5
1.3 Maximum Ratings	5
1.4 Parameter Derating Information	5
1.5 Physical Dimensions	5
1.6 Functional Diagram	5
1.7 High Temperature Test Precautions	5
<b>2. <u>APPLICABLE DOCUMENTS</u></b>	<b>9</b>
<b>3. <u>TERMS, DEFINITIONS, ABBREVIATIONS, SYMBOLS AND UNITS</u></b>	<b>9</b>
<b>4. <u>REQUIREMENTS</u></b>	<b>9</b>
4.1 General	9
4.2 Deviations from Generic Specification	9
4.2.1 Deviations from Special In-process Controls	9
4.2.2 Deviations from Final Production Tests (Chart II)	9
4.2.3 Deviations from Burn-in and Electrical Measurements (Chart III)	10
4.2.4 Deviations from Qualification Tests (Chart IV)	10
4.2.5 Deviations from Lot Acceptance Tests (Chart V)	10
4.3 Mechanical Requirements	10
4.3.1 Dimension Check	10
4.3.2 Weight	10
4.3.3 Terminal Strength	10
4.4 Materials and Finishes	11
4.4.1 Case	11
4.4.2 Lead Material and Finish	11
4.5 Marking	11
4.5.1 General	11
4.5.2 Lead Identification	11
4.5.3 The SCC Component Number	11
4.5.4 Traceability Information	12
4.5.5 Marking of Small Components	12
4.6 Electrical Measurements	12
4.6.1 Electrical Measurements at Room Temperature	12
4.6.2 Electrical Measurements at High and Low Temperatures	12
4.6.3 Circuits for Electrical Measurements	12



	<u>Page</u>	
4.7	Burn-in Tests	13
4.7.1	Parameter Drift Values	13
4.7.2	Conditions for Burn-in	13
4.7.3	Electrical Circuits for Burn-in	13
4.8	Environmental and Endurance Tests	18
4.8.1	Electrical Measurements on Completion of Environmental Tests	18
4.8.2	Electrical Measurements at Intermediate Points during Endurance Tests	18
4.8.3	Electrical Measurements on Completion of Endurance Tests	18
4.8.4	Conditions for Operating Life Tests (Part of Endurance Testing)	18
4.8.5	Electrical Circuits for Operating Life Tests	18
4.8.6	Conditions for High Temperature Storage Test (Part of Endurance Testing)	18

### **TABLES**

1(a)	Type Variants	6
1(b)	Maximum Ratings	6
2	Electrical Measurements at Room Temperature - d.c. parameters	14
	Electrical Measurements at Room Temperature - a.c. parameters	14
3	Electrical Measurements at High and Low Temperatures	15
4	Parameter Drift Values	15
5	Conditions for Burn-in and Operating Life Tests	17
6	Electrical Measurements at Intermediate Points and on Completion of Endurance Testing	19

### **FIGURES**

1	Parameter Derating Information	7
2	Physical Dimensions	8
3	Functional Diagram	8
4	Circuit for Electrical Measurements - Reverse Recovery Time	16

### **APPENDICES (Applicable to specific Manufacturers only)**

None.

**1. GENERAL****1.1 SCOPE**

This specification details the ratings, physical and electrical characteristics, test and inspection data for Diodes, Silicon, Power Rectifier, Fast Recovery, based on Types 1N5415 through 1N5420.

It shall be read in conjunction with ESA/SCC Generic Specification No. 5000, the requirements of which are supplemented herein.

**1.2 COMPONENT TYPE VARIANTS**

Variants of the basic diodes specified herein, which are also covered by this specification, are listed in Table 1(a).

**1.3 MAXIMUM RATINGS**

The maximum ratings, which shall not be exceeded at any time during use or storage, applicable to the diodes specified herein, are scheduled in Table 1(b).

**1.4 PARAMETER DERATING INFORMATION**

The derating information applicable to the diodes specified herein is shown in Figure 1.

**1.5 PHYSICAL DIMENSIONS**

The physical dimensions of the diodes specified herein are shown in Figure 2.

**1.6 FUNCTIONAL DIAGRAM**

The functional diagram, showing lead identification, of the diodes specified herein, is shown in Figure 3.

**1.7 HIGH TEMPERATURE TEST PRECAUTIONS**

For tin-lead plated or solder-dipped lead finish, all tests to be performed at a temperature that exceeds +125°C shall be carried out in a 100% inert atmosphere.

**TABLE 1(a) - COMPONENT TYPE VARIANTS**

(1) VARIANT	(2) TYPE	(3) REVERSE VOLTAGE  (V)	(4) BREAKDOWN VOLTAGE  (V)	(5) JUNCTION CAPACITANCE  (pF)	(6) REVERSE RECOVERY TIME  (ns)	(7) Lead Material and Finish
01	1N5415	50	55	550	150	A10
02	1N5415	50	55	550	150	A3 or A4
03	1N5416	100	110	430	150	A10
04	1N5416	100	110	430	150	A3 or A4
05	1N5417	200	220	250	150	A10
06	1N5417	200	220	250	150	A3 or A4
07	1N5418	400	440	165	150	A10
08	1N5418	400	440	165	150	A3 or A4
09	1N5419	500	550	140	250	A10
10	1N5419	500	550	140	250	A3 or A4
11	1N5420	600	660	120	400	A10
12	1N5420	600	660	120	400	A3 or A4

**TABLE 1(b) - MAXIMUM RATINGS**

No.	CHARACTERISTIC	SYMBOL	MAXIMUM RATING	UNIT	NOTES
1	Forward Surge Current	$I_{FSM}$	80	A	1
2	Reverse Voltage	$V_R$	See Note 2	V	
3	Average Output Rectified Current	$I_O$	3.0	A	3
4	Operating Temperature Range	$T_{op}$	-65 to +175	°C	$T_{amb}$
5	Storage Temperature Range	$T_{stg}$	-65 to +200	°C	
6	Soldering Temperature	$T_{sol}$	+245	°C	4

**NOTES**

1. Sinusoidal, with period = 8.3ms maximum.
2. See Column 3 of Table 1(a).
3. At  $T_{amb} = \leq +55^\circ\text{C}$ . For derating of  $I_O$  with  $T_L$ , see Figure 1.
4. Duration 10 seconds maximum at a distance of not less than 1.5mm from the can and the same lead shall not be resoldered until 3 minutes have elapsed.



**FIGURE 1 - PARAMETER DERATING INFORMATION**

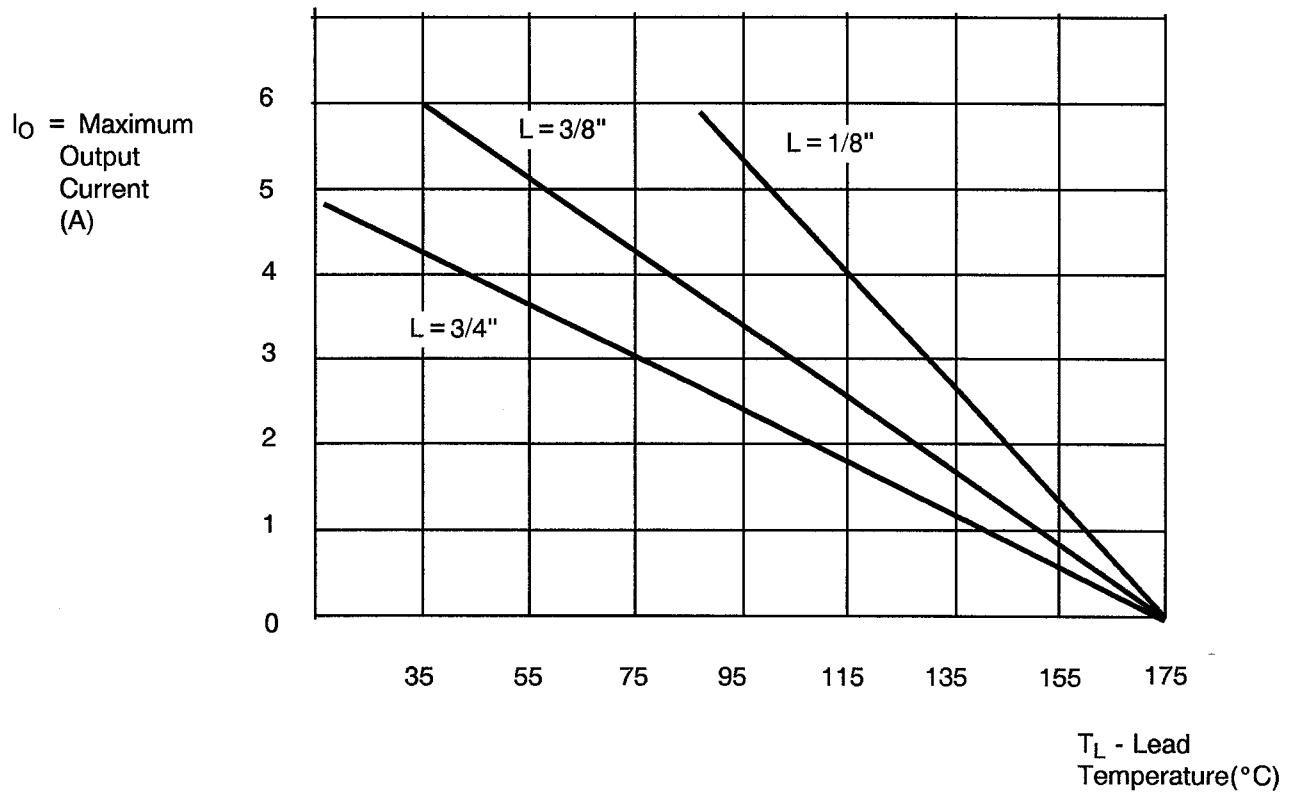

**NOTES**

1. L = Lead length from body in inches.

Output Current Derating with Lead Temperature  
for Different Lead Lengths



**FIGURE 2 - PHYSICAL DIMENSIONS**

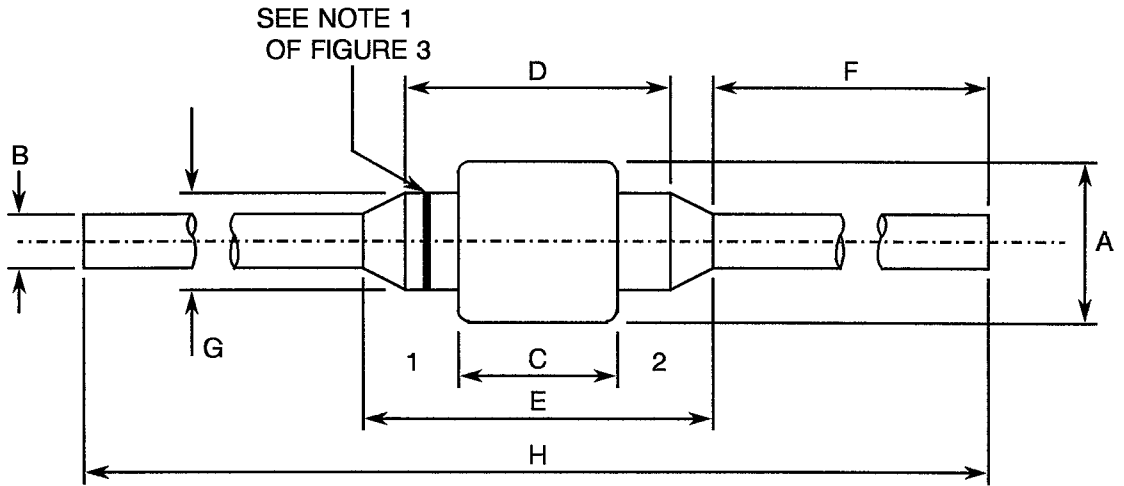

SYMBOL	INCHES		MILLIMETRES	
	MIN.	MAX.	MIN.	MAX.
A	-	0.145	-	3.7
B	0.039	0.041	0.99	1.04
C	-	0.110	-	2.8
D	-	0.180	-	4.6
E	-	0.300	-	7.6
F	0.975	-	24.8	-
G	-	0.120	-	3.0
H	2.300	-	58.4	-

**FIGURE 3 - FUNCTIONAL DIAGRAM**

- 1. Cathode
- 2. Anode

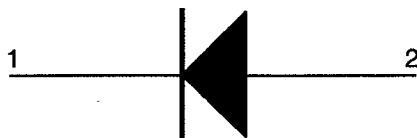

**NOTES**

- 1. The cathode end shall be marked with a coloured ring.



		<p style="text-align: center;">ESA/SCC Detail Specification No. 5103/007</p>	<p style="text-align: center;">Rev. 'B'</p>	<p>PAGE 9 ISSUE 1</p>
--	--	--	---	---------------------------

**2. APPLICABLE DOCUMENTS**

The following documents form part of this specification and shall be read in conjunction with it:-

- (a) ESA/SCC Generic Specification No. 5000 for Discrete Semiconductors.
- (b) MIL-STD-750, Test Methods and Procedures for Semiconductor Devices.

**3. TERMS, DEFINITIONS, ABBREVIATIONS, SYMBOLS AND UNITS**

For the purpose of this specification, the terms, definitions, abbreviations, symbols and units specified in ESA/SCC Basic Specification No. 21300 shall apply.

**4. REQUIREMENTS**

**4.1 GENERAL**

The complete requirements for procurement of the diodes specified herein are stated in this specification and ESA/SCC Generic Specification No. 5000 for Discrete Semiconductors. Deviations from the Generic Specification applicable to this specification only, are listed in Para. 4.2.

Deviations from the applicable Generic Specification and this Detail Specification, formally agreed with specific Manufacturers on the basis that the alternative requirements are equivalent to the ESA/SCC requirements and do not affect the components' reliability, are listed in the appendices attached to this specification.

**4.2 DEVIATIONS FROM GENERIC SPECIFICATION**

**4.2.1 Deviations from Special In-process Controls**

None.

**4.2.2 Deviations from Final Production Tests (Chart II)**

- (a) Bond Strength Test: Shall not be performed.
- (b) Die-shear Test: Shall not be performed.
- (c) Para. 9.7, Particle Impact Noise Detection (PIND) Test: Not applicable.
- (d) The following test shall be added after Para. 9.8.2, Seal Test, Fine and Gross Leak (Optional) and before Para. 9.9.3, Electrical Measurements at Room Temperature:-



Surge current in accordance with Test method 4066 of MIL-STD-750. The following test conditions shall apply:-

$T_{amb}$  :  $+25 \pm 3$  °C.  
 $I_{FSM}$  : 80A.  
Number of pulses : 5.  
Pulse rate : 1 pulse/minute.  
 $t_p$  : 8.3ms.  
Pulse form : sinusoidal.

#### 4.2.3 Deviations from Burn-in and Electrical Measurements (Chart III)

- (a) High Temperature Reverse Bias: Shall not be performed.
- (b) Para. 9.12, Radiographic Inspection: Not applicable.

#### 4.2.4 Deviations from Qualification Tests (Chart IV)

- (a) Bond Strength Test: Shall not be performed.
- (b) Die-shear Test: Shall not be performed.

#### 4.2.5 Deviations from Lot Acceptance Tests (Chart V)

None.

### 4.3 MECHANICAL REQUIREMENTS

#### 4.3.1 Dimension Check

The dimensions of the diodes specified herein shall be checked. They shall conform to those shown in Figure 2.

#### 4.3.2 Weight

The maximum weight of the diodes specified herein shall be 0.25 grammes.

#### 4.3.3 Terminal Strength

The requirements for terminal strength testing are specified in Section 9 of ESA/SCC Generic Specification No. 5000. The test conditions shall be as follows:-

Test Condition : 'A'.  
Applied Force : 22.2 Newtons.  
Duration : 15 seconds.



4.4 MATERIALS AND FINISHES

The materials and finishes shall be as specified herein. Where a definite material is not specified, a material which will enable the diodes specified herein to meet the performance requirements of this specification shall be used. Acceptance or approval of any constituent material does not guarantee acceptance of the finished product.

4.4.1 Case

Glass, hermetically sealed.

4.4.2 Lead Material and Finish

The lead material shall be Type 'A' with either Type '3 or 4' or Type '10' finish in accordance with the requirements of ESA/SCC Basic Specification No. 23500. (See Table 1(a) for Type Variants).

4.5 MARKING

4.5.1 General

The marking of all components delivered to this specification shall be in accordance with the requirements of ESA/SCC Basic Specification No. 21700. Each component shall be marked in respect of:-

- (a) Lead Identification.
- (b) The SCC Component Number.
- (c) Traceability Information.

4.5.2 Lead Identification

Lead identification shall be as shown in Figures 2 and 3.

4.5.3 The SCC Component Number

Each component shall bear the SCC Component Number which shall be constituted and marked as follows:

Detail Specification Number \_\_\_\_\_ 510300702B

Type Variant \_\_\_\_\_

Testing Level (B or C, as applicable) \_\_\_\_\_



#### 4.5.4 Traceability Information

Each component shall be marked in respect of traceability information in accordance with the requirements of ESA/SCC Basic Specification No. 21700.

#### 4.5.5 Marking of Small Components

When it is considered that the component is too small to accommodate the marking as specified above, as much as space permits shall be marked. The order of precedence shall be as follows:-

- (a) Lead Identification.
- (b) The SCC Component Number.
- (c) Traceability Information.

The marking information in full shall accompany each component in its primary package.

### 4.6 ELECTRICAL CHARACTERISTICS

#### 4.6.1 Electrical Measurements at Room Temperature

The parameters to be measured at room temperature are scheduled in Table 2. The measurements shall be performed at  $T_{amb} = +22 \pm 3$  °C.

#### 4.6.2 Electrical Measurements at High and Low Temperatures

The parameters to be measured at high and low temperatures are scheduled in Table 3.

#### 4.6.3 Circuits for Electrical Measurements

Circuits for use in performing the electrical measurements listed in Tables 2 and 3 of this specification are shown, where applicable, in MIL-STD-750 and Figure 4.



#### 4.7 BURN-IN TESTS

##### 4.7.1 Parameter Drift Values

The parameter drift values applicable to burn-in are specified in Table 4 of this specification. Unless otherwise stated, the measurements shall be performed at  $T_{amb} = +22 \pm 3$  °C. The parameter drift values ( $\Delta$ ) applicable to the parameters scheduled, shall not be exceeded. In addition to these drift value requirements, the appropriate limit value specified for a given parameter in Table 2 shall not be exceeded.

##### 4.7.2 Conditions for Burn-in

The requirements for burn-in are specified in Section 7 of ESA/SCC Generic Specification No. 5000. The conditions for burn-in shall be as specified in Table 5 of this specification.

##### 4.7.3 Electrical Circuits for Burn-in (Figure 5)

Not applicable.

**TABLE 2 - ELECTRICAL MEASUREMENTS AT ROOM TEMPERATURE - d.c. PARAMETERS**

No.	CHARACTERISTICS	SYMBOL	TEST METHOD MIL-STD-750	TEST CONDITION	LIMITS		UNIT
					MIN.	MAX.	
1	Reverse Current	$I_R$	4016	$V_R = (1) V$	-	1.0	$\mu A$
2	Forward Voltage	$V_F$	4011	$I_F = 9.0A$ See Note 2	0.6	1.5	V
3	Breakdown Voltage	$V_{(BR)}$	4021	$I_R = 50\mu A$	(3)	-	V

**TABLE 2 - ELECTRICAL MEASUREMENTS AT ROOM TEMPERATURE - a.c. PARAMETERS**

No.	CHARACTERISTICS	SYMBOL	TEST METHOD MIL-STD-750	TEST CONDITION (Note 6)	LIMITS		UNIT
					MIN.	MAX.	
4	Junction Capacitance	$C_J$	4001	$V_R = 4.0V$ $f = 1.0MHz$	-	(4)	pF
5	Reverse Recovery Time	$t_{rr}$	4031	$I_F = 0.5A$ $I_R = 1.0A$ $I_{RR} = 0.25A$ (See Figure 4)	-	(5)	ns

**NOTES**

1. See Column 3 of Table 1(a).
2. Pulse Measurement with  $t_p = 300\mu s$ ; Duty Cycle  $\leq 2\%$ .
3. See Column 4 of Table 1(a).
4. See Column 5 of Table 1(a).
5. See Column 6 of Table 1(a).
6. A.C. parameters shall be performed on a sample basis LTPD=7, or less (see Annex 1 of ESA/SCC Generic Specification No. 5000).

**TABLE 3 - ELECTRICAL MEASUREMENTS AT HIGH AND LOW TEMPERATURES**

No.	CHARACTERISTICS	SYMBOL	TEST METHOD MIL-STD-750	TEST CONDITIONS	LIMITS		UNIT
					MIN.	MAX.	
1	Reverse Current	$I_R$	4016	$V_R = (1)$ $T_{amb} = +100 (+0-5) ^\circ C$	-	20	$\mu A$

**NOTES**

1. See Column 3 of Table 1(a).

**TABLE 4 - PARAMETER DRIFT VALUES**

No.	CHARACTERISTICS	SYMBOL	SPEC. AND/OR TEST METHOD	TEST CONDITION	CHANGE LIMITS ( $\Delta$ )	UNIT
1	Reverse Current	$I_R$	As per Table 2	As per Table 2	$\pm 0.25$ or (1) $\pm 100$	$\mu A$ %
2	Forward Voltage	$V_F$	As per Table 2	As per Table 2	$\pm 100$	mV

**NOTES**

1. Whichever is the greater referred to the initial value.



**FIGURE 4 - CIRCUITS FOR ELECTRICAL MEASUREMENTS**

REVERSE RECOVERY TIME

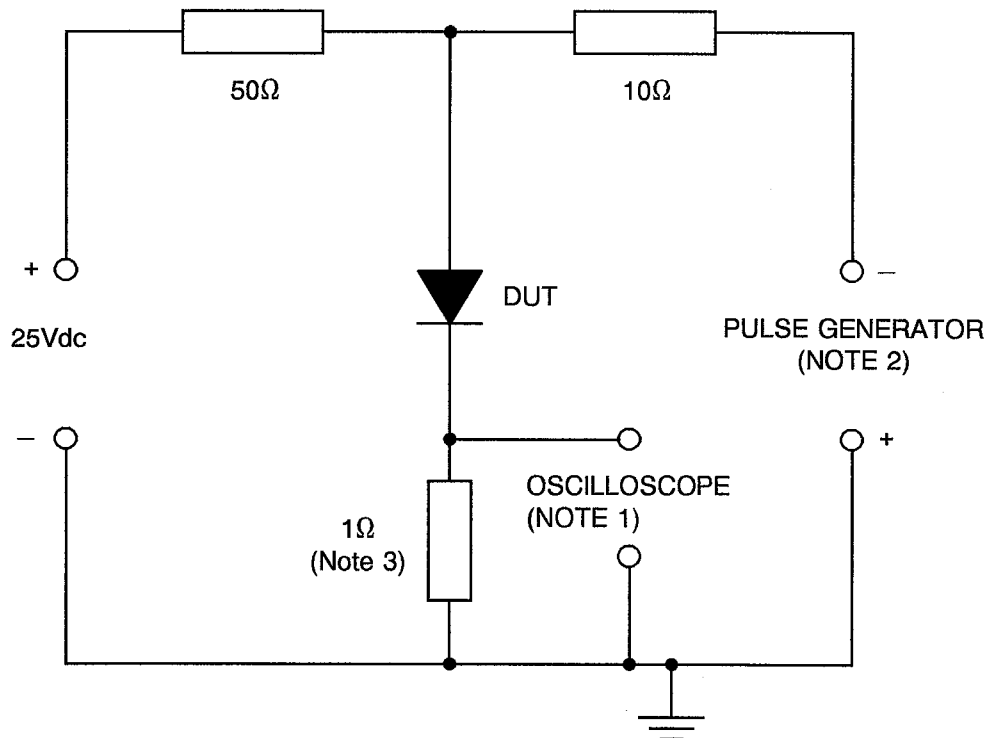

**NOTES**

1. Oscilloscope :  $t_r \leq 3.0\text{ns}$ ;  $Z_{IN} = 50\Omega$ .
2. Pulse Generator :  $t_r \leq 8.0\text{ns}$ ;  $Z_S = 10\Omega$ .
3. Current viewing resistor, non-inductive, coaxial.



**SCC**ESA/SCC Detail Specification  
No. 5103/007

PAGE 17

ISSUE 1

**TABLE 5 - CONDITIONS FOR BURN-IN AND OPERATING LIFE TESTS**

No.	CHARACTERISTICS	SYMBOL	CONDITION	UNIT
1	Ambient Temperature	$T_{amb}$	$+25 \pm 3$	$^{\circ}\text{C}$
2	Peak Reverse Voltage	$V_{RM}$	$V_{RM} = (1)$	Vrms
5	Frequency	f	50 to 60	Hz
4	Average Output Rectified Current	$I_o$	3.0 See Note 2	A

**NOTES**

1. See Column 3 of Table 1(a).
2. Mounting shall be performed without bending or soldering the leads.  
Lead length from body to mounting shall be 0.12 inches (3.14mm) minimum.



4.8 ENVIRONMENTAL AND ENDURANCE TESTS (CHARTS IV AND V OF ESA/SCC GENERIC SPECIFICATION No. 5000)

4.8.1 Electrical Measurements on Completion of Environmental Tests

The parameters to be measured on completion of environmental tests are scheduled in Table 2. The measurements shall be performed at  $T_{amb} = +22 \pm 3$  °C.

4.8.2 Electrical Measurements at Intermediate Points during Endurance Tests

The parameters to be measured at intermediate points during endurance tests are scheduled in Table 6.

4.8.3 Electrical Measurements on Completion of Endurance Tests

The parameters to be measured on completion of endurance testing are scheduled in Table 6. The measurements shall be performed at  $T_{amb} = +22 \pm 3$  °C.

4.8.4 Conditions for Operating Life Tests (Part of Endurance Testing)

The requirements for operating life testing are specified in Section 9 of ESA/SCC Generic Specification No. 5000. The conditions for operating life testing shall be as specified in Table 5 of this specification.

4.8.5 Electrical Circuits for Operating Life Tests (Figure 5)

Not applicable.

4.8.6 Conditions for High Temperature Storage Test (Part of Endurance Testing)

The requirements for the high temperature storage test are specified in ESA/SCC Generic Specification No. 5000. The conditions for high temperature storage shall be  $T_{amb} = +200 (+0-5)$  °C.

**TABLE 6 - ELECTRICAL MEASUREMENTS AT INTERMEDIATE POINTS AND ON COMPLETION OF ENDURANCE TESTING**

No.	CHARACTERISTICS	SYMBOL	SPEC. AND/OR TEST METHOD	TEST CONDITION	LIMITS		UNIT
					MIN.	MAX.	
1	Reverse Current	$I_R$	As per Table 2	As per Table 2	-	1.0	$\mu A$
2	Forward Voltage	$V_F$	As per Table 2	As per Table 2	0.6	1.5	V
3	Reverse Recovery Time	$t_{rr}$	As per Table 2	As per Table 2	-	(1)	ns

**NOTES**

1. See Column 6 of Table 1(a).