



european space agency  
agence spatiale européenne

Pages 1 to 15

**FLANGE LOADS, HIGH POWER, 50Ω**

**BASED ON TYPE EMC8745**

**ESA/SCC Detail Specification No. 3403/007**

**SCC**

**space components  
coordination group**

Issue/Rev.	Date	Approved by	
		SCCG Chairman	ESA Director General or his Deputy
Issue 1	December 1994		
Revision 'A'	November 1996		

**SCC**ESA/SCC Detail Specification  
No. 3403/007

Rev. 'A'

PAGE 2

ISSUE 1

DOCUMENTATION CHANGE NOTICE

Rev. Letter	Rev. Date	Reference	CHANGE Item	Approved DCR No.
'A'	Nov. '96	P1. Cover page P2. DCN P5. Para. 1.1 : In second sentence "4001" corrected to "3403" P8. Para. 4.2.5 : Entry numbering corrected		None None 23833 23833

**TABLE OF CONTENTS**

	<u>Page</u>
<b>1. <u>GENERAL</u></b>	<b>5</b>
1.1 Scope	5
1.2 Component Type Variants	5
1.3 Maximum Ratings	5
1.4 Parameter Derating Information	5
1.5 Physical Dimensions	5
1.6 Handling Precautions	5
<b>2. <u>APPLICABLE DOCUMENTS</u></b>	<b>5</b>
<b>3. <u>TERMS, DEFINITIONS, ABBREVIATIONS, SYMBOLS AND UNITS</u></b>	<b>5</b>
<b>4. <u>REQUIREMENTS</u></b>	<b>8</b>
4.1 General	8
4.2 Deviations from Generic Specification	8
4.2.1 Deviations from Special In-process Controls	8
4.2.2 Deviations from Final Production Tests	8
4.2.3 Deviations from Burn-in and Electrical Measurements	8
4.2.4 Deviations from Qualification Tests	8
4.2.5 Deviations from Lot Acceptance Tests	8
4.3 Mechanical Requirements	8
4.3.1 Dimension Check	8
4.3.2 Weight	8
4.4 Materials and Finishes	9
4.4.1 Load Interface	9
4.4.2 Chip Resistor	9
4.5 Marking	9
4.5.1 General	9
4.5.2 The SCC Component Number	9
4.5.3 Traceability Information	9
4.6 Electrical Measurements	10
4.6.1 Electrical Measurements at Room Temperature	10
4.6.2 Electrical Measurements at High and Low Temperatures	10
4.6.3 Circuits for Electrical Measurements	10
4.7 Burn-in Tests	10
4.7.1 Parameter Drift Values	10
4.7.2 Conditions for Burn-in	10
4.7.3 Electrical Circuits for Burn-in	10
4.8 Environmental and Endurance Tests	13
4.8.1 Measurements and Inspections on Completion of Environmental Tests	13
4.8.2 Measurements and Inspections at Intermediate Points during Endurance Tests	13
4.8.3 Measurements and Inspections on Completion of Endurance Tests	13
4.8.4 Conditions for Operating Life Tests	13
4.8.5 Electrical Circuit for Operating Life Tests	13

**TABLES**

	<u>Page</u>
1(a) Type Variants	6
1(b) Maximum Ratings	6
2 Electrical Measurements at Room Temperature	11
3 Electrical Measurements at High and Low Temperatures	11
4 Parameter Drift Values	12
5 Conditions for Burn-in and Operating Life Tests	12
6 Measurements and Inspections on Completion of Environmental Tests and at Intermediate Points and on Completion of Endurance Testing	14

**FIGURES**

1 Parameter Derating Information	7
2 Physical Dimensions	7
3 Functional Diagram	7
4 Circuit for Electrical Measurements	N/A
5 Electrical Circuit for Burn-in and Operating Life Tests	N/A

**APPENDICES (Applicable to specific Manufacturers only)**

'A' AGREED DEVIATIONS FOR EMC TECHNOLOGY CORP. (U.S.)	15
---	----



## 1. GENERAL

### 1.1 SCOPE

This specification details the ratings, physical and electrical characteristics, test and inspection data for a Flange Load, High Power, 50Ω, based on Type EMC8745. It shall be read in conjunction with ESA/SCC Generic Specification No. 3403, the requirements of which are supplemented herein.

### 1.2 COMPONENT TYPE VARIANTS

Variants of the basic type flange loads specified herein, which are also covered by this specification, are given in Table 1(a).

### 1.3 MAXIMUM RATINGS

The maximum ratings, which shall not be exceeded at any time during use or storage, applicable to the flange loads specified herein, are as scheduled in Table 1(b).

### 1.4 PARAMETER DERATING INFORMATION

The parameter derating information applicable to the flange loads specified herein is given in Figure 1.

### 1.5 PHYSICAL DIMENSIONS

As per Figure 2.

### 1.6 HANDLING PRECAUTIONS

**Warning:** These flange loads contain Beryllia in the substrate and have a Beryllium Copper termination.

## 2. APPLICABLE DOCUMENTS

The following documents form part of this specification and shall be read in conjunction with it:-

- (a) ESA/SCC Generic Specification No. 3403, Attenuators and Loads, RF, Coaxial, Fixed.
- (b) MIL-STD-202, Test Methods for Electronic and Electrical Component Parts.

## 3. TERMS, DEFINITIONS, ABBREVIATIONS, SYMBOLS AND UNITS

For the purpose of this specification, the terms, definitions, abbreviations, symbols and units specified in ESA/SCC Basic Specification No. 21300 shall apply.

**TABLE 1(a) - TYPE VARIANTS**

Variant	Based on Type	Rated Power	Frequency Range	VSWR (Max.)	Terminals	Terminal Material and Finish
01	EMC8745	40W	DC to 5.0 GHz	1.5	Tab	M7

**TABLE 1(b) - MAXIMUM RATINGS**

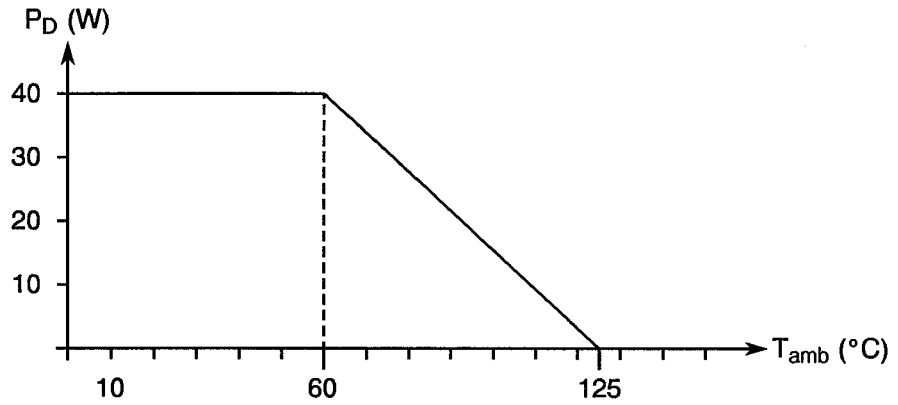
No.	Characteristics	Symbol	Maximum Ratings	Unit	Remarks
1	RF Power (Average)	P <sub>CW</sub>	40	W	Note 1
2	RF Power (Peak)	P <sub>PK</sub>	400	W	Note 2
3	Operating Temperature Range	T <sub>op</sub>	- 55 to + 125	°C	Note 3
4	Storage Temperature Range	T <sub>stg</sub>	- 55 to + 150	°C	Note 4
5	Soldering Temperature	T <sub>sol</sub>	+ 200	°C	Note 5

**NOTES**

1. For thermal interface temperature 60°C max.
2. Pulse length 10µs, 10% duty cycle.
3. Heatsink temperature. Derating according to Figure 1.
4. Ambient Temperature.
5. Duration 10 seconds maximum.

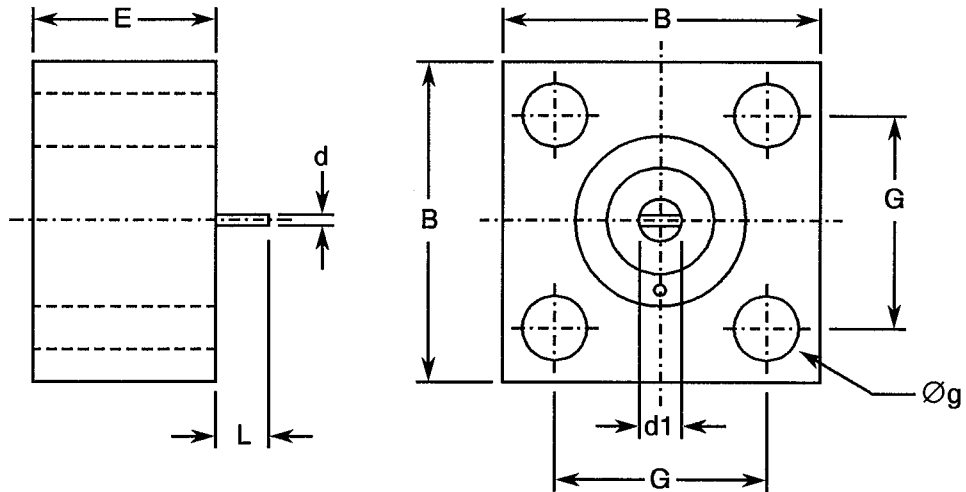


**FIGURE 1 - PARAMETER DERATING INFORMATION**



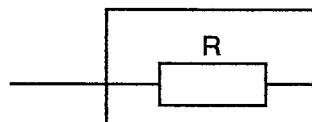
Power Dissipation versus Temperature



**FIGURE 2 - PHYSICAL DIMENSIONS**



SYMBOL	MILLIMETRES		NOTES
	MIN.	MAX.	
B	12.57	12.83	4 holes
d	0.10	0.15	
d1	1.14	1.40	
E	8.76	9.02	
Øg	2.46	2.72	
G	8.51	8.76	
L	1.22	1.47	

**FIGURE 3 - FUNCTIONAL DIAGRAM**



 	<p style="text-align: center;">ESA/SCC Detail Specification No. 3403/007</p>	<p style="text-align: center;">Rev. 'A'</p>	<p>PAGE 8 ISSUE 1</p>
---	--	---	---------------------------

4. REQUIREMENTS

4.1 GENERAL

The complete requirements for procurement of the flange loads specified herein shall be as stated in this specification and ESA/SCC Generic Specification No. 3403. Deviations from the Generic Specification, applicable to this specification only, are listed in Para. 4.2.

Deviations from the applicable Generic Specification and this Detail Specification, formally agreed with specific Manufacturers on the basis that the alternative requirements are equivalent to the ESA/SCC requirements and do not affect the components' reliability, are listed in the appendices attached to this specification.

4.2 DEVIATIONS FROM GENERIC SPECIFICATION

4.2.1 Deviations from Special In-process Controls

None.

4.2.2 Deviations from Final Production Tests (Chart II)

None.

4.2.3 Deviations from Burn-in and Electrical Measurements (Chart III)

(a) Para. 9.4, "Contact Insertion and Withdrawal Forces": Not applicable.

4.2.4 Deviations from Qualification Tests (Chart IV)

(a) Para. 9.11, "Coupling Proof Torque": Not applicable.

(b) Para. 9.12, "Engagement and Separation Forces": Not applicable.

(c) Para. 9.13, "Connector Repeatability": Not applicable.

(d) Para. 9.14.3, "Operating Life Test": The test shall be performed using d.c. voltage.

(e) Para. 9.18, "Power Sensitivity": Not applicable.

(f) To the Endurance Subgroup, a Solderability Test in accordance with to MIL-STD-202, Method 208 shall be added. It shall be performed before Operating Life Test.

4.2.5 Deviations from Lot Acceptance Tests (Chart V)

(a) Para. 9.12, "Engagement and Separation Forces": Not applicable.

(b) Para. 9.13, "Connector Repeatability": Not applicable.

(c) Para. 9.14.3, "Operating Life Test": The test shall be performed using d.c. voltage.

(d) To Level 2, a Solderability Test in accordance with MIL-STD-202, Method 208 shall be added. It shall be performed before Operating Life Test.

4.3 MECHANICAL REQUIREMENTS

4.3.1 Dimension Check

The dimensions of the flange loads specified herein shall be checked. They shall conform to those shown in Figure 2.

4.3.2 Weight

The maximum weight of the flange loads specified herein shall be 20 grammes.





4.4 MATERIALS AND FINISHES

The materials and finishes shall be as specified herein. Where a definite material is not specified, a material which will enable the components specified herein to meet the performance requirements of this specification shall be used. Acceptance or approval of any constituent material does not guarantee acceptance of the finished product.

4.4.1 Load Interface

4.4.1.1 Termination

The termination material shall be Type 'M' with Type '7' finish in accordance with the requirements of ESA/SCC Basic Specification No. 23500.

4.4.1.2 Dielectric

The dielectric material shall be teflon.

4.4.1.3 Flange Case

Copper, 10µm min Nickel plated.

4.4.1.4 End Cap

Stainless steel, passivated.

4.4.2 Chip Resistor

Beryllia substrate, thickfilm platinum silver terminations.

4.5 MARKING

4.5.1 General

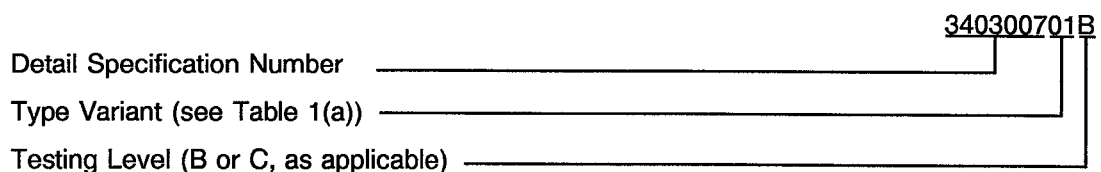
The marking of all components delivered to this specification shall be in accordance with the requirements of ESA/SCC Basic Specification No. 21700 and the following paragraphs. When the component is too small to accommodate all of the marking specified, as much as space permits shall be marked and the marking information, in full, shall accompany each component in its primary package.

The information to be marked, and the order of precedence, shall be as follows:-

- (a) The SCC Component Number.
- (b) Traceability Information.

4.5.2 The SCC Component Number

Each component shall bear the SCC Component Number which shall be constituted and marked as follows:



**N.B.**

A BeO warning mark must be present on the device and primary package in accordance with the requirements of ESA/SCC Basic Specification No. 21700.

4.5.3 Traceability Information

Each component shall be marked in respect of traceability information in accordance with the requirements of ESA/SCC Basic Specification No. 21700.



#### 4.6 ELECTRICAL MEASUREMENTS

##### 4.6.1 Electrical Measurements at Room Temperature

The parameters to be measured at room temperature are scheduled in Table 2. Unless otherwise specified, the measurements shall be performed at  $T_{amb} = +22 \pm 3$  °C.

##### 4.6.2 Electrical Measurements at High and Low Temperatures

The parameters to be measured at high and low temperatures are scheduled in Table 3. Unless otherwise specified, the measurements shall be performed at  $T_{amb} = +125(+0-5)$  °C and  $-55(+5-0)$  °C respectively.

##### 4.6.3 Circuits for Electrical Measurements

Circuits for electrical measurements are referenced in ESA/SCC Generic Specification No. 3403.

#### 4.7 BURN-IN TESTS

##### 4.7.1 Parameter Drift Values

The parameter drift values applicable to burn-in are specified in Table 4 of this specification. Unless otherwise stated, measurements shall be performed at  $T_{amb} = +22 \pm 3$  °C. The parameter drift values ( $\Delta$ ) applicable to the parameters scheduled, shall not be exceeded. In addition to these drift value requirements for a given parameter, the appropriate limit value specified in Table 2 shall not be exceeded.

##### 4.7.2 Conditions for Burn-in

The requirements for burn-in are specified in Section 7 of ESA/SCC Generic Specification No. 3403. The conditions for burn-in shall be as specified in Table 5 of this specification.

On completion of burn-in, a recovery period of  $24 \pm 2$  hours is necessary before performance of the end measurements.

##### 4.7.3 Electrical Circuits for Burn-in (Figure 5)

Not applicable

**TABLE 2 - ELECTRICAL MEASUREMENTS AT ROOM TEMPERATURE**

No.	Characteristics	Symbol	ESA/SCC 3403 Test Method	Test Conditions	Limits		Unit
					Min.	Max.	
1	Voltage Standing Wave Ratio	VSWR	Para. 9.6.1.1	Test Frequency Range: 1.0 to 3.0 GHz (Note 1)	-	1.50	-
2	Resistance	R	Para. 9.6.1.4	MIL-STD-202 Method 303 d.c. voltage	47.5	52.5	$\Omega$

**NOTES**

1. To be measured in 200 MHz steps.

**TABLE 3 - ELECTRICAL MEASUREMENTS AT HIGH AND LOW TEMPERATURES**

No.	Characteristics	Symbol	ESA/SCC 3403 Test Method	Test Conditions (Note 1)	Limits		Unit
					Min.	Max.	
1	Voltage Standing Wave Ratio	VSWR	Para. 9.6.1.1	Test Frequency Range: 1.0 to 3.0 GHz (Note 2)	-	1.50	-
2	Resistance	R	Para. 9.6.1.4	MIL-STD-202 Method 303 d.c. voltage	47.5	52.5	$\Omega$

**NOTES**

1. Measurements to be made on 2 samples only. If 1 failure occurs, the complete lot shall be measured.
2. To be measured in 200 MHz steps.

**FIGURE 4 - CIRCUITS FOR ELECTRICAL MEASUREMENTS**

Not applicable.

**TABLE 4 - PARAMETER DRIFT VALUES**

No.	Characteristics	Symbol	Spec. and/or Test Method	Test Conditions	Change Limits ( $\Delta$ )	Unit
2	Resistance	R	As per Table 2	As per Table 2	$\pm 1.0$	%

**TABLE 5 - CONDITIONS FOR BURN-IN AND OPERATING LIFE TESTS**

No.	Characteristics	Symbol	Condition	Unit
1	Heatsink Temperature	T	+ 60	$^{\circ}\text{C}$
2	Power Dissipation	$P_D$	40	W

**FIGURE 5 - ELECTRICAL CIRCUIT FOR BURN-IN AND OPERATING LIFE TESTS**

Not applicable.



- 4.8 ENVIRONMENTAL AND ENDURANCE TESTS (CHARTS IV AND V OF ESA/SCC GENERIC SPECIFICATION NO. 3403)
- 4.8.1 Measurements and Inspections on Completion of Environmental Tests  
The parameters to be measured and inspections to be performed on completion of environmental tests are scheduled in Table 6. Unless otherwise stated, the measurements shall be performed at  $T_{amb} = +22 \pm 3 \text{ }^\circ\text{C}$ .
- 4.8.2 Measurements and Inspections at Intermediate Points during Endurance Tests  
The parameters to be measured and inspections to be performed at intermediate points during endurance tests are scheduled in Table 6. Unless otherwise stated, the measurements shall be performed at  $T_{amb} = +22 \pm 3 \text{ }^\circ\text{C}$ .
- 4.8.3 Measurements and Inspections on Completion of Endurance Tests  
The parameters to be measured and inspections to be performed on completion of endurance testing are as scheduled in Table 6 of this specification. Unless otherwise stated, the measurements shall be performed at  $T_{amb} = +22 \pm 3 \text{ }^\circ\text{C}$ .
- 4.8.4 Conditions for Operating Life Tests (Part of Endurance Testing)  
The requirements for operating life testing are specified in Section 9 of ESA/SCC Generic Specification No. 3403. The conditions for operating life testing shall be as specified in Table 5 of this specification.
- 4.8.5 Electrical Circuits for Operating Life Tests (Figure 5)  
Not applicable.



**TABLE 6 - MEASUREMENTS AND INSPECTIONS ON COMPLETION OF ENVIRONMENTAL TESTS AND AT INTERMEDIATE POINTS AND ON COMPLETION OF ENDURANCE TESTING**

No.	ESA/SCC GENERIC SPECIFICATION NO. 3403		MEASUREMENTS AND INSPECTIONS		SYMBOL	LIMITS		UNIT
	ENVIRONMENTAL AND ENDURANCE TESTS (1)	TEST METHOD AND CONDITIONS	IDENTIFICATION	CONDITIONS		MIN.	MAX.	
01	Vibration	Para. 9.7	<b>During Last Cycle</b> Intermittent Contact <b>Final Measurements</b> Visual Examination Resistance	Open or Shorts  - Table 2 Item 2	-  - R	-  - 47.5	0.5  - 52.5	ms  - Ω
02	Shock or Bump	Para. 9.8	Visual Examination Resistance	- Table 2 Item 2	- R	- 47.5	- 52.5	- Ω
03	Rapid Change of Temperature	Para. 9.9	Visual Examination Resistance	- Table 2 Item 2	- R	- 47.5	- 52.5	- Ω
04	Climatic Sequence Dry Heat Cold Test	Para. 9.10 Para. 9.10.2 Para. 9.10.4	Resistance Resistance  <b>Final Measurements</b>  External Visual Inspection Resistance	Table 3 Item 2 Table 3 Item 2  After a recovery period of 1 to 24 hours Para. 9.5 of ESA/SCC 3403 Table 2 Item 2	R R  - R	47.5 47.5  - 47.5	52.5 52.5  - 52.5	Ω Ω  - Ω
05	Coupling Proof Torque	Para. 9.11	Not applicable	-	-	-	-	-
06	Engagement and Separation Forces	Para. 9.12	Not applicable	-	-	-	-	-
07	Connector Repeatability	Para. 9.13	Not applicable	-	-	-	-	-
08	Operating Life	Para. 9.14	<b>Initial Measurements</b> Resistance <b>Final Measurements</b> Visual Examination Resistance	Table 2 Item 2  - Table 2 Item 2	R  - R	47.5  - 47.5	52.5  - 52.5	Ω  - Ω
09	Residual Magnetism	Para. 9.15	Residual Magnetism	Para. 9.15 of ESA/SCC 3403	-	-	20	γ
10	RF Leakage	Para. 9.16	RF Leakage	Para. 9.16	-	-85	-	dB
11	Peak Power	Para. 9.17	Resistance	Table 2 Item 2	R	47.5	52.5	Ω
12	Power Sensitivity	Para. 9.18	Not applicable	-	-	-	-	-
13	Corrosion	Para. 9.19	Visual Examination	After drying at +40°C for 24 hours	-	-	-	-
14	Solderability	MIL-STD-202 Test Method 208	Visual Examination	-	-	-	-	-

**NOTES**

1. The tests in this table refer to either Chart IV or V and shall be used as applicable.



**APPENDIX 'A'**

AGREED DEVIATIONS FOR EMC TECHNOLOGY CORP. (U.S.)

ITEMS AFFECTED	DESCRIPTION OF DEVIATIONS
Para. 4.2.2	(a) Para. 9.6.1.1, Voltage Standing Wave Ratio (i) At Room Temperature may be performed to Internal Document TP8729, "RF Measurement at +25°C Automatic Analyser".
Para. 4.2.3	(a) Para. 9.6.1.1, Voltage Standing Wave Ratio (i) At Room Temperature may be performed to Internal Document TP8729, "RF Measurement at +25°C Automatic Analyser". (ii) At High and Low Temperatures may be performed to Internal Document TP8730, "RF Measurement at Temperature Extremes".
Para. 4.2.4	(a) Para. 9.6.1.1, Voltage Standing Wave Ratio (i) At Room Temperature may be performed to Internal Document TP8729, "RF Measurement at +25°C Automatic Analyser". (ii) At High and Low Temperatures may be performed to Internal Document TP8730, "RF Measurement at Temperature Extremes".
Para. 4.2.5	(a) Para. 9.6.1.1, Voltage Standing Wave Ratio (i) At Room Temperature may be performed to Internal Document TP8729, "RF Measurement at +25°C Automatic Analyser". (ii) At High and Low Temperatures may be performed to Internal Document TP8730, "RF Measurement at Temperature Extremes".