



europaean space agency
agence spatiale européenne

Pages 1 to 22

**DIODES, MICROWAVE, SILICON,
PIN, BROADBAND,
BASED ON TYPES ML4661P, ML4662, ML4663P,
ML4664, ML4665P, ML4666, ML4667P, ML4668,
ML4669P AND ML4670
ESA/SCC Detail Specification No. 5513/016**



**space components
coordination group**

| Issue/Rev. | Date | Approved by | |
|------------|------------|---------------|---------------------------------------|
| | | SCCG Chairman | ESA Director General or his Deputy |
| Issue 1 | April 1993 | <i>Pommes</i> | <i>J. Hub</i> |
| | | | |
| | | | |
| | | | |



SCC

ESA/SCC Detail Specification
No. 5513/016

PAGE 2

ISSUE 1

DOCUMENTATION CHANGE NOTICE

| Rev. Letter | Rev. Date | Reference | CHANGE Item | Approved DCR No. |
|----------------|--------------|-----------|----------------|---------------------|
| | | | | |

**TABLE OF CONTENTS**

| | <u>Page</u> |
|---|-------------|
| 1. <u>GENERAL</u> | 5 |
| 1.1 Scope | 5 |
| 1.2 Type Variants | 5 |
| 1.3 Maximum Ratings | 5 |
| 1.4 Parameter Derating Information | 5 |
| 1.5 Physical Dimensions | 5 |
| 1.6 Functional Diagram | 5 |
| 1.7 Handling Precautions | 5 |
| 2. <u>APPLICABLE DOCUMENTS</u> | 5 |
| 3. <u>TERMS, DEFINITIONS, ABBREVIATIONS, SYMBOLS AND UNITS</u> | 5 |
| 4. <u>REQUIREMENTS</u> | 11 |
| 4.1 General | 11 |
| 4.2 Deviations from Generic Specification | 11 |
| 4.2.1 Deviations from Special In-process Controls | 11 |
| 4.2.2 Deviations from Final Production Tests | 11 |
| 4.2.3 Deviations from Burn-in and Electrical Measurements | 11 |
| 4.2.4 Deviations from Qualification Tests | 11 |
| 4.2.5 Deviations from Lot Acceptance Tests | 11 |
| 4.3 Mechanical and Environmental Requirements | 12 |
| 4.3.1 Dimension Check | 12 |
| 4.3.2 Weight | 12 |
| 4.3.3 Terminal Strength | 12 |
| 4.4 Materials and Finishes | 12 |
| 4.4.1 Case | 12 |
| 4.4.2 Lead Materials and Finish | 12 |
| 4.5 Marking | 12 |
| 4.5.1 General | 12 |
| 4.5.2 Anode Identification | 13 |
| 4.5.3 The SCC Component Number | 13 |
| 4.5.4 Traceability Information | 13 |
| 4.6 Electrical Measurements | 13 |
| 4.6.1 Electrical Measurements at Room Temperature | 13 |
| 4.6.2 Electrical Measurements at High and Low Temperatures | 13 |
| 4.6.3 Circuits for Electrical Measurements | 13 |
| 4.7 Burn-in Tests | 13 |
| 4.7.1 Parameter Drift Values | 13 |
| 4.7.2 Conditions for High Temperature Reverse Bias Burn-in | 13 |
| 4.7.3 Conditions for Power Burn-in | 14 |
| 4.7.4 Electrical Circuits for High Temperature Reverse Bias and Power Burn-in | 14 |
| 4.8 Environmental and Endurance Tests | 20 |
| 4.8.1 Electrical Measurements on Completion of Environmental Tests | 20 |
| 4.8.2 Electrical Measurements at Intermediate Points and on Completion of Endurance Tests | 20 |
| 4.8.3 Conditions for Operating Life Tests | 20 |
| 4.8.4 Electrical Circuits for Operating Life Tests | 20 |
| 4.9 Total Dose Irradiation Testing | 20 |
| 4.9.1 Application | 20 |
| 4.9.2 Bias Conditions | 20 |
| 4.9.3 Electrical Measurements | 20 |
| 4.10 Special Testing | 20 |



Page

TABLES

| | | |
|------|---|----|
| 1(a) | Type Variants | 6 |
| 1(b) | Maximum Ratings | 7 |
| 2 | Electrical Measurements at Room Temperature - D.C. Parameters | 15 |
| | Electrical Measurements at Room Temperature - A.C. Parameters | 15 |
| 3 | Electrical Measurements at High and Low Temperatures | 16 |
| 4 | Parameter Drift Values | 16 |
| 5(a) | Conditions for High Temperature Reverse Bias Burn-in | 18 |
| 5(b) | Conditions for Power Burn-in | 18 |
| 5(c) | Conditions for Operating Life Tests | 18 |
| 6 | Electrical Measurements at Intermediate Points and on Completion of Endurance Testing | 21 |
| 7 | Electrical Measurements During and on Completion of Irradiation Testing | 22 |

FIGURES

| | | |
|------|---|----|
| 1 | Parameter Derating Information | 8 |
| 2 | Physical Dimensions | 9 |
| 3 | Functional Diagram | 10 |
| 4 | Circuits for Electrical Measurements | 17 |
| 5(a) | Electrical Circuit for High Temperature Reverse Bias Burn-in | 19 |
| 5(b) | Electrical Circuit for Power Burn-in and Operating Life Tests | 19 |
| 6 | Bias Conditions for Irradiation Testing | 21 |

APPENDICES (Applicable to specific Manufacturers only)

None.

**1. GENERAL****1.1 SCOPE**

This specification details the ratings, physical and electrical characteristics, test and inspection data for a Diode, Microwave, Silicon, PIN, Broadband, based on Types ML4661P, ML4662, ML4663P, ML4664, ML4665P, ML4666, ML4667P, ML4668, ML4669P and ML4670. It shall be read in conjunction with ESA/SCC Generic Specification No. 5010, the requirements of which are supplemented herein.

1.2 TYPE VARIANTS

Variants of the basic diodes specified herein, which are also covered by this specification are given in Table 1(a).

1.3 MAXIMUM RATINGS

The maximum ratings, which shall not be exceeded at any time during use or storage, applicable to the diodes specified herein, are as scheduled in Table 1(b).

1.4 PARAMETER DERATING INFORMATION

The derating information applicable to the diodes specified herein is shown in Figure 1.

1.5 PHYSICAL DIMENSIONS

The physical dimensions of the diodes specified herein are shown in Figure 2.

1.6 FUNCTIONAL DIAGRAM

The functional diagram, showing lead identification, of the diodes specified herein, is shown in Figure 3.

1.7 HANDLING PRECAUTIONS

These devices are susceptible to damage by electrostatic discharge. Therefore, suitable precautions shall be employed for protection during all phases of manufacture, testing, packaging, shipment and any handling.

These components are Categorised as Class 2 with a Minimum Critical Path Failure Voltage of 3400V.

2. APPLICABLE DOCUMENTS

The following documents form part of this specification and shall be read in conjunction with it:-

- (a) ESA/SCC Generic Specification No. 5010 for Discrete Microwave Semiconductor Components.
- (b) MIL-STD-750, Test Methods and Procedures for Semiconductor Devices.

3. TERMS, DEFINITIONS, ABBREVIATIONS, SYMBOLS AND UNITS

For the purpose of this specification, the terms, definitions, abbreviations, symbols and units specified in ESA/SCC Basic Specification No. 21300 shall apply.

**TABLE 1(a) - TYPE VARIANTS**

| (1) VARIANT | (2) BASED ON TYPE | (3) FIGURE | (4) INSERTION LOSS IL (dB) (Maximum) | (5) LEAD MATERIAL AND FINISH |
|----------------|-------------------------|---------------|--|---------------------------------------|
| 01 | ML4661P - 116 | 2(a) | 0.7 | D2 |
| 02 | ML4661P - 144 | 2(b) | 0.7 | D2 |
| 03 | ML4661P - 144B | 2(b) | 0.7 | D2 |
| 04 | ML4662 - 116 | 2(a) | 0.7 | D2 |
| 05 | ML4662 - 144 | 2(b) | 0.7 | D2 |
| 06 | ML4662 - 144B | 2(b) | 0.7 | D2 |
| 07 | ML4663P - 116 | 2(a) | 0.7 | D2 |
| 08 | ML4663P - 144 | 2(b) | 0.7 | D2 |
| 09 | ML4663P - 144B | 2(b) | 0.7 | D2 |
| 10 | ML4664 - 116 | 2(a) | 0.7 | D2 |
| 11 | ML4664 - 144 | 2(b) | 0.7 | D2 |
| 12 | ML4664 - 144B | 2(b) | 0.7 | D2 |
| 13 | ML4665P - 116 | 2(a) | 0.7 | D2 |
| 14 | ML4665P - 144 | 2(b) | 0.7 | D2 |
| 15 | ML4665P - 144B | 2(b) | 0.7 | D2 |
| 16 | ML4666 - 116 | 2(a) | 0.7 | D2 |
| 17 | ML4666 - 144 | 2(b) | 0.7 | D2 |
| 18 | ML4666 - 144B | 2(b) | 0.7 | D2 |
| 19 | ML4667P - 116 | 2(a) | 0.7 | D2 |
| 20 | ML4667P - 144 | 2(b) | 0.7 | D2 |
| 21 | ML4667P - 144B | 2(b) | 0.7 | D2 |
| 22 | ML4668 - 116 | 2(a) | 0.7 | D2 |
| 23 | ML4668 - 144 | 2(b) | 0.7 | D2 |
| 24 | ML4668 - 144B | 2(b) | 0.7 | D2 |
| 25 | ML4669P - 116 | 2(a) | 1.0 | D2 |
| 26 | ML4669P - 144 | 2(b) | 1.0 | D2 |
| 27 | ML4669P - 144B | 2(b) | 1.0 | D2 |
| 28 | ML4670 - 116 | 2(a) | 1.0 | D2 |
| 29 | ML4670 - 144 | 2(b) | 1.0 | D2 |
| 30 | ML4670 - 144B | 2(b) | 1.0 | D2 |

**TABLE 1(b) - MAXIMUM RATINGS**

| No. | CHARACTERISTIC | SYMBOL | MAXIMUM RATINGS | UNIT | REMARKS |
|-----|--|-----------|--|------|------------|
| 1 | D.C. Reverse Voltage Variants 01 to 06 Variants 07 to 12 Variants 13 to 18 Variants 19 to 24 Variants 25 to 30 | V_R | -40 -70 -100 -150 -200 | V | Note 1 |
| 2 | D.C. Forward Current (Continuous) Variants 01 to 12 Variants 13 to 30 | I_F | 150 200 | mA | Note 2 |
| 3 | R.F. Power Dissipation Variants 01, 03, 07 and 09 Variants 02 and 08 Variants 04, 06, 23 and 29 Variant 05 Variants 10, 12, 13, 15, 19 and 21 Variants 11, 14 and 20 Variants 16 and 18 Variant 17 Variants 22, 24, 28 and 30 Variants 25 and 27 Variant 26 | P_{tot} | 1.56 1.09 2.08 1.32 3.13 1.67 4.17 1.92 5.00 3.57 1.79 | W | Note 1 |
| 4 | Operating Temperature Range | T_{op} | -65 to +150 | °C | T_{case} |
| 5 | Storage Temperature Range | T_{stg} | -65 to +150 | °C | |
| 6 | Soldering Temperature | T_{sol} | +230 | °C | Note 3 |

NOTES

1. At $T_{case} = +25^{\circ}\text{C}$. For derating at $T_{case} > +25^{\circ}\text{C}$, see Figure 1.
2. At $T_{case} = +100^{\circ}\text{C}$. For derating at $T_{case} > +100^{\circ}\text{C}$, see Figure 1.
3. Duration 5 seconds maximum at a distance of not less than 1.5mm from the body and the same termination shall not be resoldered until 3 minutes have elapsed.



FIGURE 1 - PARAMETER DERATING INFORMATION

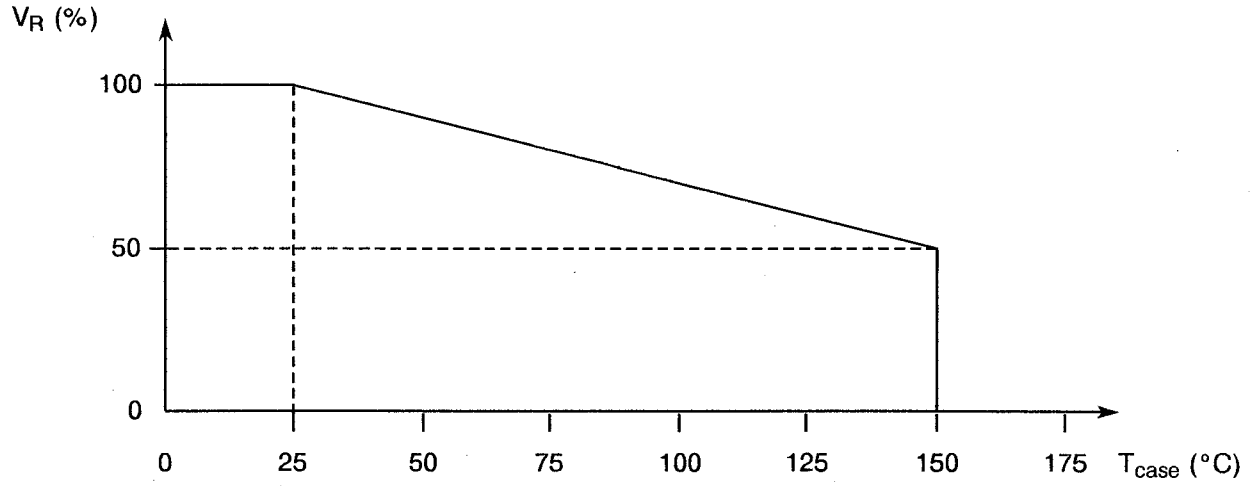

Reverse Voltage versus Temperature

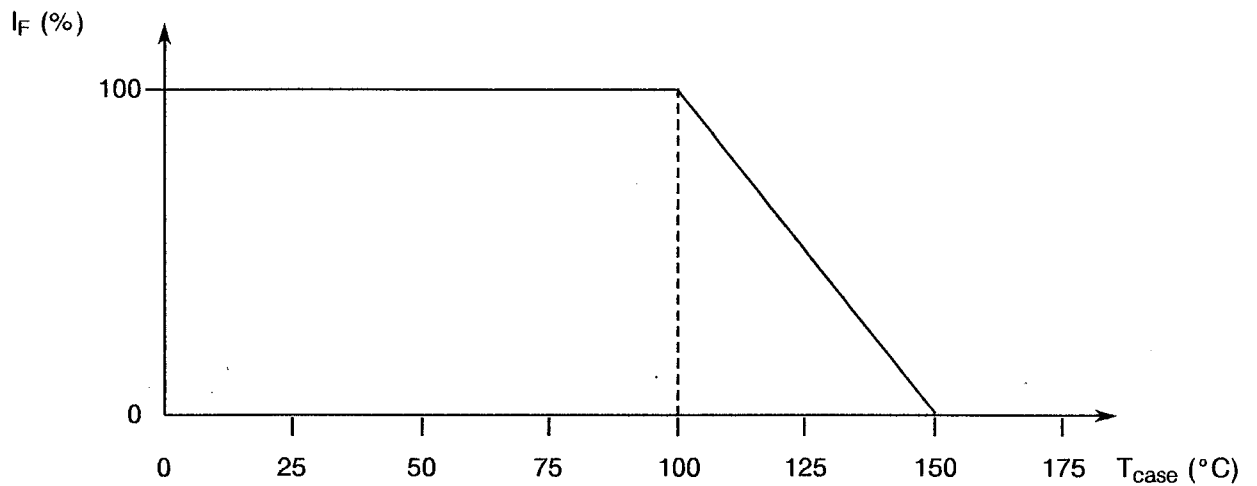

Forward Current versus Temperature

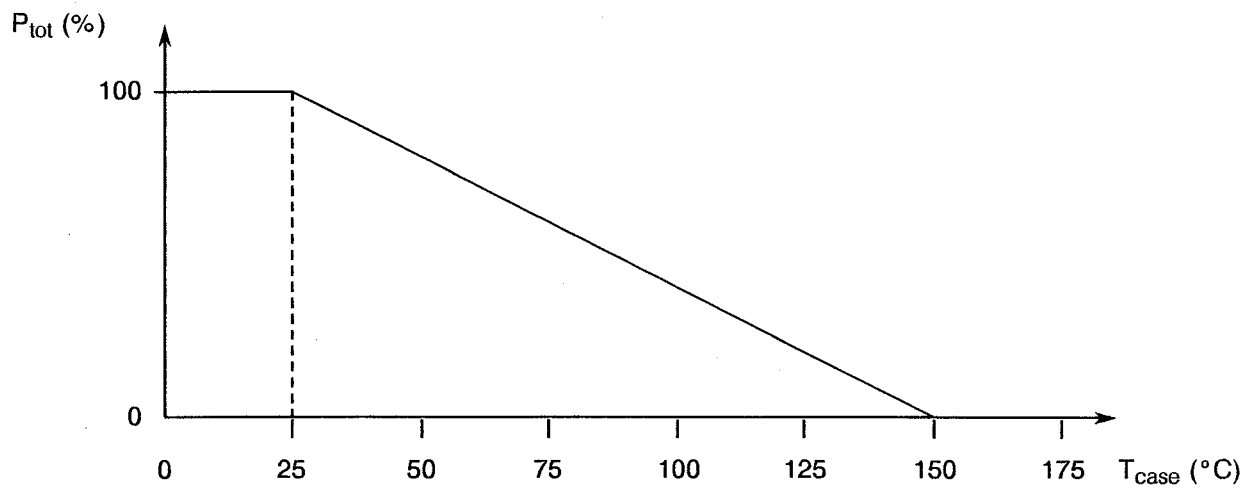

Power Dissipation versus Temperature

FIGURE 2 - PHYSICAL DIMENSIONS

FIGURE 2(a) - VARIANTS 01, 04, 07, 10, 13, 16, 19, 22, 25, 28

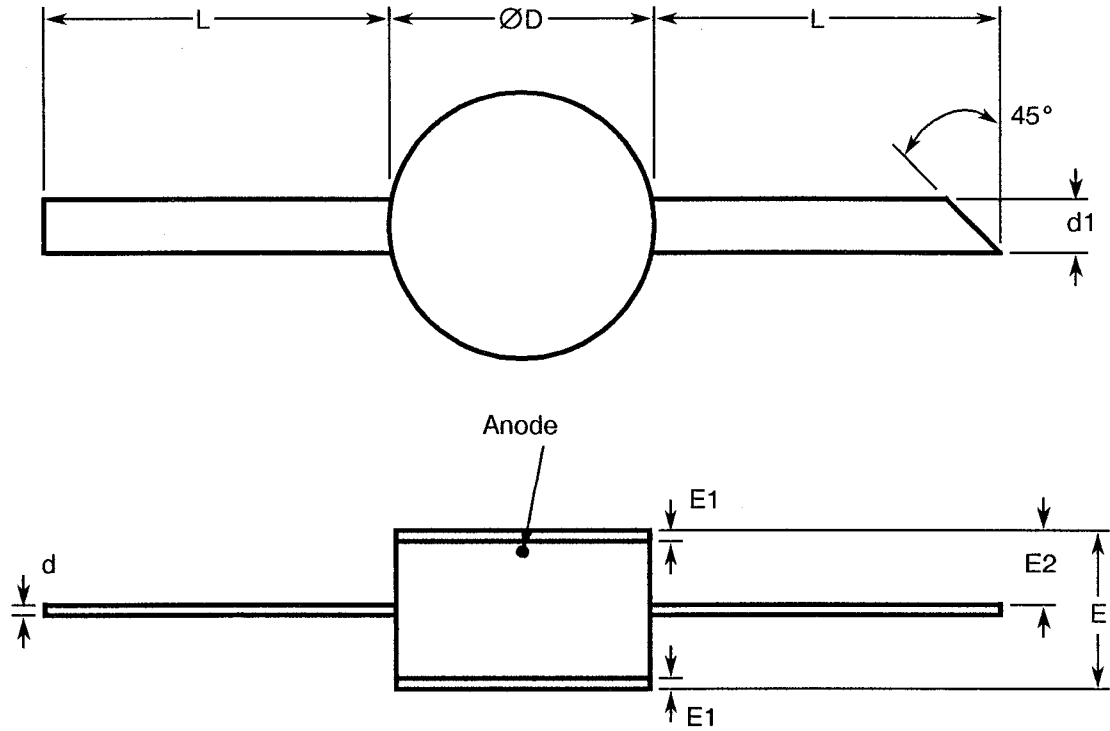

| SYMBOL | MILLIMETRES | |
|--------|-------------|------|
| | MIN | MAX |
| d | 0.08 | 0.13 |
| d1 | 0.46 | 0.56 |
| ØD | 2.29 | 2.79 |
| E | 2.00 | 2.50 |
| E1 | 0.20 | 0.35 |
| E2 | 0.90 | 1.20 |
| L | 2.00 | 2.50 |

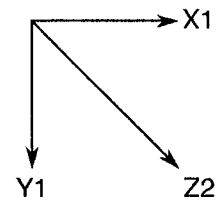
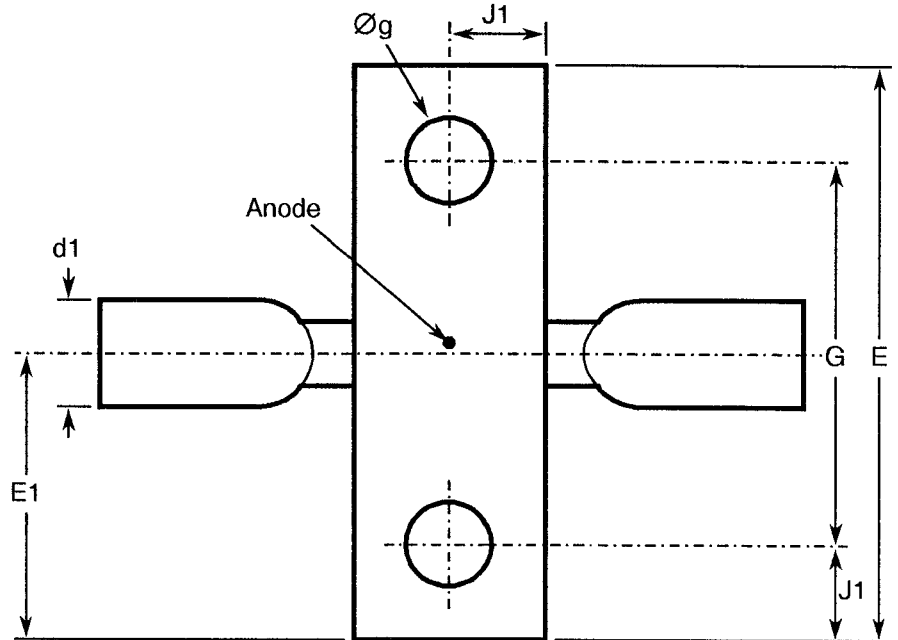



FIGURE 2 - PHYSICAL DIMENSIONS (CONTINUED)

FIGURE 2(b) - VARIANTS 02, 03, 05, 06, 08, 09, 11, 12, 14, 15, 17, 18, 20, 21, 23, 24, 26, 27, 29, 30



| SYMBOL | MILLIMETRES | |
|-----------------|-------------|-------|
| | MIN | MAX |
| B | 3.94 | 4.19 |
| d | 0.07 | 0.25 |
| d1 | 0.50 | 1.30 |
| $\varnothing d$ | 0.25 | 0.40 |
| E | 10.16 | 10.67 |
| E1 | 4.95 | 5.46 |
| $\varnothing g$ | 2.34 | 2.54 |
| G | 6.10 | 6.60 |
| H | 3.05 | 3.30 |
| H1 | 1.12 | 1.92 |
| J1 | 1.91 | 2.16 |
| L | 2.00 | - |
| L1 | 0.10 | 1.00 |
| L2 | 1.00 | - |

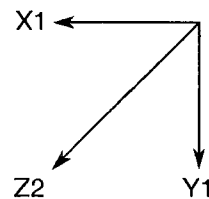
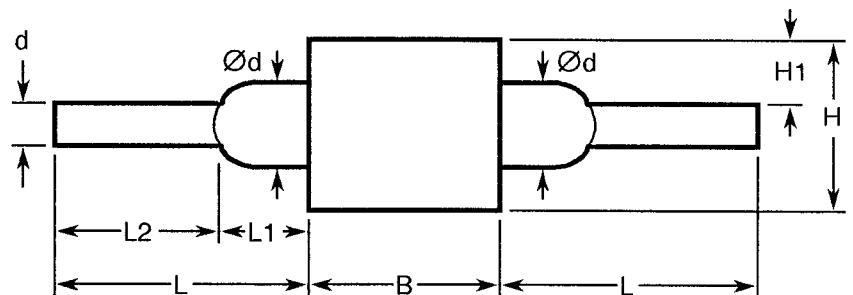
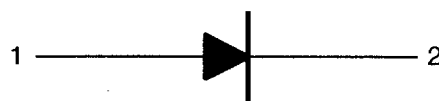

FIGURE 3 - FUNCTIONAL DIAGRAM



- 1. Anode
- 2. Cathode

NOTES

- 1. The anode shall be marked with a red dot.
- 2. The heatsink end shall be the same as the anode end.



4. REQUIREMENTS

4.1 GENERAL

The complete requirements for procurement of the diodes specified herein shall be as stated in this specification and ESA/SCC Generic Specification No. 5010 for Discrete Microwave Semiconductor Components. Deviations from the Generic Specification applicable to this specification only, are listed in Para. 4.2.

Deviations from the applicable Generic Specification and this Detail Specification, formally agreed with specific Manufacturers on the basis that the alternative requirements are equivalent to the ESA/SCC requirements and do not affect the components' reliability, are listed in the appendices attached to this specification.

4.2 DEVIATIONS FROM GENERIC SPECIFICATION

4.2.1 Deviations from Special In-process Controls

- (a) Para. 5.2.2, Total Dose Irradiation Testing: Shall be performed during qualification and extension of qualification.
- (b) Para. 5.2.2, Total Dose Irradiation Testing: Shall be performed during procurement on a lot acceptance basis at the total dose irradiation level specified in the purchase order.
- (c) Para. 5.3, Wafer Lot Acceptance: Shall be performed as an S.E.M. Inspection only.

4.2.2 Deviations from Final Production Tests (Chart II)

- (a) Para. 6.2, Pre-burn-in: Shall be performed in accordance with Para. 9.21(a).
- (b) Para. 9.2.2, Die Shear: Shall not be performed for Variants 02, 03, 04, 05, 06, 08, 09, 10, 11, 12, 14, 15, 16, 17, 18, 20, 21, 22, 23, 24, 26, 27, 28, 29 and 30 and no additional thermal tests shall be performed to replace this test.
- (c) Para. 9.14, Vibration, Variable Frequency: Shall not be performed.

4.2.3 Deviations from Burn-in and Electrical Measurements (Chart III)

- (a) Para. 7.1.1(a), High Temperature Reverse Bias Burn-in: Shall be performed at 50% of rated V_R .

4.2.4 Deviations from Qualification Tests (Chart IV)

- (a) Para. 9.2.3, Bond Strength: Shall not be performed for Variants 04, 05, 06, 10, 11, 12, 16, 17, 18, 22, 23, 24, 28, 29 and 30.
- (b) Para. 9.2.4, Die Shear: Shall not be performed for Variants 02, 03, 04, 05, 06, 08, 09, 10, 11, 12, 14, 15, 16, 17, 18, 20, 21, 22, 23, 24, 26, 27, 28, 29 and 30 for which thermal resistance measurements shall be performed in accordance with Table 2 of this specification.
- (c) Para. 9.23, Special Testing: Shall not be performed.

4.2.5 Deviations from Lot Acceptance Tests (Chart V)

- (a) Para. 9.23, Special Testing: Shall not be performed.



4.3 MECHANICAL AND ENVIRONMENTAL REQUIREMENTS

4.3.1 Dimension Check

The dimensions of the diodes specified herein shall be checked. They shall conform to those shown in Figure 2.

4.3.2 Weight

The maximum weight of the diodes specified herein shall be 0.14 grammes for Variants 01, 04, 07, 10, 13, 16, 19, 22, 25 and 28 and 0.99 grammes for Variants 02, 03, 05, 06, 08, 09, 11, 12, 14, 15, 17, 18, 20, 21, 23, 24, 26, 27, 29 and 30.

4.3.3 Terminal Strength

The requirements for terminal strength testing are specified in Section 9 of ESA/SCC Generic Specification No. 5010. The test conditions shall be as follows:-

(a) Condition: 'A' (Tension).

Variants 01, 04, 07, 10, 13, 16, 19, 22, 25 and 28:

(b) Force: 3.1N.

(c) Duration: 5 seconds.

Variants 02, 03, 05, 06, 08, 09, 11, 12, 14, 15, 17, 18, 20, 21, 23, 24, 26, 27, 29 and 30:

(b) Force: 5.1N.

(c) Duration: 5 seconds.

4.4 MATERIALS AND FINISHES

The materials and finishes shall be as specified herein. Where a definite material is not specified, a material which will enable the diodes specified herein to meet the performance requirements of this specification shall be used. Acceptance or approval of any constituent material shall not guarantee acceptance of the finished product.

4.4.1 Case

The case shall be hermetically sealed and have a ceramic or kovar body. The lid shall be welded or preform soldered.

4.4.2 Lead Materials and Finish

The material shall be Type 'D' with Type '2' finish in accordance with the requirements of ESA/SCC Basic Specification No. 23500.

4.5 MARKING

4.5.1 General

The marking of components delivered to this specification shall be in accordance with the requirements of ESA/SCC Basic Specification No. 21700 and the following paragraphs. When the component is too small to accommodate all of the marking specified, as much as space permits shall be marked and the marking information, in full, shall accompany the component in its primary package.

The information to be marked and the order of precedence, shall be as follows:-

(a) Anode Identification.

(b) The SCC Component Number.

(c) Traceability Information.



4.5.2 Anode Identification

Anode identification shall be as shown in Figures 2 and 3 of this specification.

4.5.3 The SCC Component Number

Each component shall bear the SCC Component Number which shall be constituted and marked as follows:

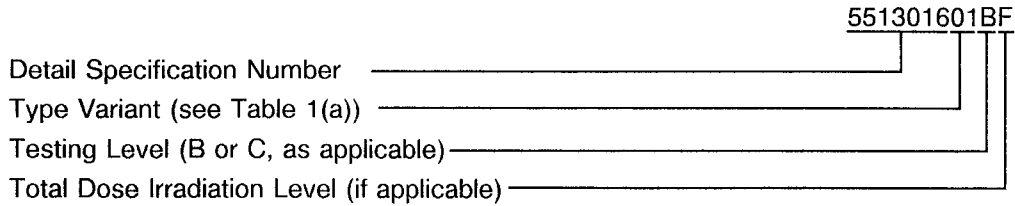

The Total Dose Irradiation Level designation shall be added for those devices for which a sample has been successfully tested to the level in question. For these devices, a code letter shall be added in accordance with the requirements of ESA/SCC Basic Specification No. 22900.

4.5.4 Traceability Information

Each component shall be marked in respect of traceability information as defined in ESA/SCC Basic Specification No. 21700.

4.6 ELECTRICAL MEASUREMENTS

4.6.1 Electrical Measurements at Room Temperature

The parameters to be measured at room temperature are scheduled in Table 2. Unless otherwise specified, the measurements shall be performed at $T_{amb} = +22 \pm 3$ °C.

4.6.2 Electrical Measurements at High and Low Temperatures

The parameters to be measured at high and low temperatures are scheduled in Table 3. Unless otherwise specified, the measurements shall be performed at $T_{amb} = +150(+0 - 3)$ °C.

4.6.3 Circuits for Electrical Measurements

Circuits for use in performing electrical measurements listed in Table 2 of this specification are shown in Figure 4.

4.7 BURN-IN TESTS

Burn-in shall be Category 3 of Chart III(a).

4.7.1 Parameter Drift Values

The parameter drift values applicable to burn-in are specified in Table 4 of this specification. Unless otherwise stated, the measurements shall be performed at $T_{amb} = +22 \pm 3$ °C. The parameter drift values (Δ) applicable to the scheduled parameters shall not be exceeded. In addition to these drift value requirements for a given parameter, the appropriate limit value specified in Table 2 shall not be exceeded.

4.7.2 Conditions for High Temperature Reverse Bias Burn-in

The requirements for the high temperature reverse bias burn-in are specified in Section 7 of ESA/SCC Generic Specification No. 5010. The conditions for high temperature reverse bias burn-in shall be as specified in Table 5(a) of this specification.

| | | | |
|---|--|--|--------------------|
|  | ESA/SCC Detail Specification No. 5513/016 | | PAGE 14 ISSUE 1 |
|---|--|--|--------------------|

4.7.3 Conditions for Power Burn-in

The requirements for power burn-in are specified in Section 7 of ESA/SCC Generic Specification No. 5010. The conditions for power burn-in shall be as specified in Table 5(b) of this specification.

4.7.4 Electrical Circuits for High Temperature Reverse Bias and Power Burn-in

Circuits for use in performing the H.T.R.B and power burn-in tests are shown in Figures 5(a) and 5(b) of this specification.



TABLE 2 - ELECTRICAL MEASUREMENTS AT ROOM TEMPERATURE - D.C. PARAMETERS

| No. | CHARACTERISTICS | SYMBOL | MIL-STD-750 TEST METHOD | TEST CONDITIONS | LIMITS | | UNIT |
|-----|--------------------|---------------|-------------------------|---|--------|---|----------------------|
| | | | | | MIN. | MAX. | |
| 1 | Reverse Current 1 | I_{R1} | 4016 | $V_R = \text{Note 1}$ | - | 10 | μA |
| 2 | Reverse Current 2 | I_{R2} | 4016 | $V_R = \text{Note 2}$ | - | 100 | nA |
| 3 | Forward Voltage | V_F | 4011 | $I_F = 100\text{mA}$ | - | 1.0 | V |
| 4 | Thermal Resistance | $R_{TH(J-C)}$ | 3101 | $I_F = 1.0\text{A}$ Note 3 Variants 01, 03, 07, 09 Variants 02, 08 Variants 04, 06, 23, 29 Variant 05 Variants 10, 12, 13, 15, 19, 21 Variants 11, 14, 20 Variants 16, 18 Variant 17 Variants 22, 24, 28, 30 Variants 25, 27 Variant 26 | - | 80 115 60 95 40 75 30 65 25 35 70 | $^{\circ}\text{C/W}$ |

NOTES

- 1 Table 1(b), Item 1.
2. Half the value of Table 1(b), Item 1.
3. Pulsed measurement, pulse width = 4.0 μs , p.r.f. = 1.0kHz.

TABLE 2 - ELECTRICAL MEASUREMENTS AT ROOM TEMPERATURE - A.C. PARAMETERS

| No. | CHARACTERISTICS | SYMBOL | MIL-STD-750 TEST METHOD | TEST FIG. | TEST CONDITIONS | LIMITS | | UNIT |
|-----|---------------------------|----------|-------------------------|-----------|--|--------|--------------------------------|------|
| | | | | | | MIN. | MAX. | |
| 5 | Minority Carrier Lifetime | τ_L | - | 4(a) | $I_F = 10\text{mA}$ Variants 01 to 06 Variants 07 to 12 Variants 13 to 18 Variants 19 to 24 $I_F = 4.5\text{mA}$ Variants 25 to 30 | - | 40 120 250 400 700 | ns |
| 6 | Insertion Loss | IL | - | 4(b) | $V_R = -10\text{V}$ Variants 01 to 24 $V_R = -20\text{V}$ Variants 25 to 30 | - | 0.7 1.0 | dB |
| 7 | Isolation | ISO | - | 4(b) | $I_F = 100\text{mA}$ | 20 | - | dB |

TABLE 3 - ELECTRICAL MEASUREMENTS AT HIGH AND LOW TEMPERATURES

| No. | CHARACTERISTICS | SYMBOL | SPEC.AND/OR TEST METHOD | TEST CONDITIONS | LIMITS | | UNIT |
|-----|-------------------|----------|----------------------------|--------------------|--------|------|---------|
| | | | | | MIN. | MAX. | |
| 2 | Reverse Current 2 | I_{R2} | As per Table 2 | As per Table 2 | - | 10 | μA |

TABLE 4 - PARAMETER DRIFT VALUES

| No. | CHARACTERISTICS | SYMBOL | SPEC.AND/OR TEST METHOD | TEST CONDITIONS | CHANGE LIMITS (Δ) | UNIT |
|-----|-------------------|----------|----------------------------|--------------------|---|---------|
| 2 | Reverse Current 2 | I_{R2} | As per Table 2 | As per Table 2 | ± 10 (1) or (2) ± 100 (1) | nA % |
| 3 | Forward Voltage | V_F | As per Table 2 | As per Table 2 | ± 100 (1) | mV |

NOTES

- $\Delta 1 = \Delta 2 = \Delta 3$.
- Whichever is the greater, referred to the initial measurement.



FIGURE 4 - CIRCUITS FOR ELECTRICAL MEASUREMENTS

FIGURE 4(a) - MINORITY CARRIER LIFETIME

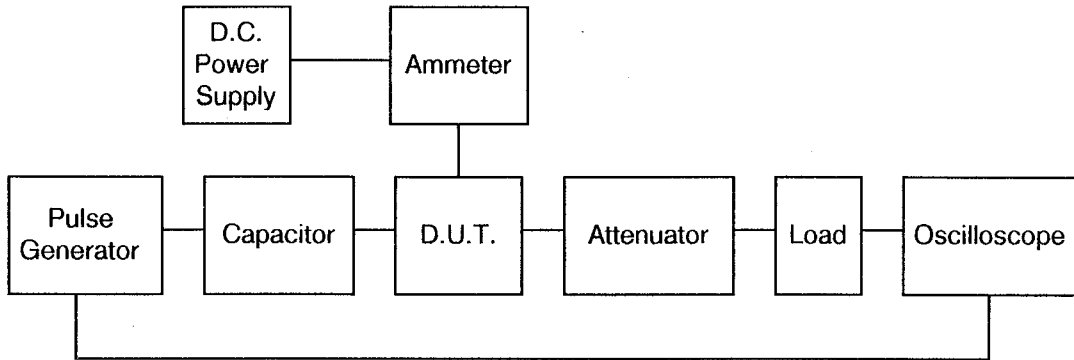
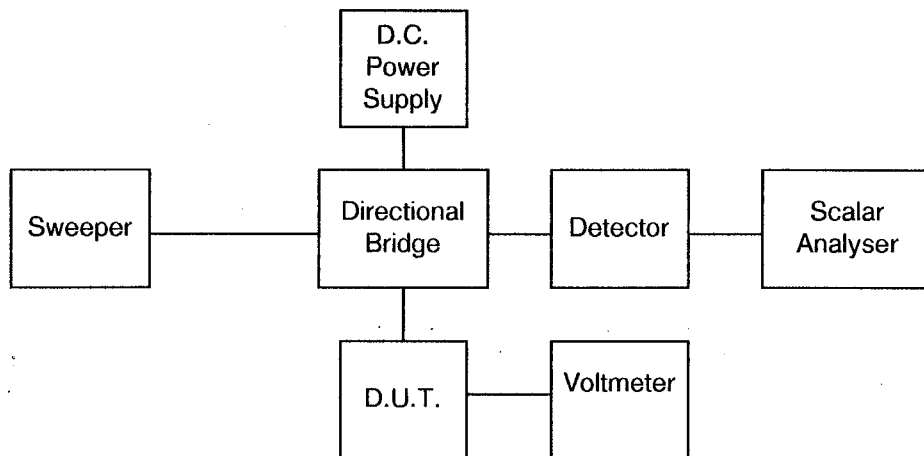

FIGURE 4(b) - INSERTION LOSS AND ISOLATION



**TABLE 5(a) - CONDITIONS FOR HIGH TEMPERATURE REVERSE BIAS BURN-IN**

| No. | CHARACTERISTICS | SYMBOL | CONDITIONS | UNIT |
|-----|---------------------|-----------|-----------------|------|
| 1 | Ambient Temperature | T_{amb} | + 150(+ 0 - 3) | °C |
| 2 | Reverse Voltage | V_R | Note 1 | V |

NOTES

1. Half the value of Table 1(b), Item 1.

TABLE 5(b) - CONDITIONS FOR POWER BURN-IN

| No. | CHARACTERISTICS | SYMBOL | CONDITIONS | UNIT |
|-----|---------------------|-----------|---|------|
| 1 | Ambient Temperature | T_{amb} | + 125(+ 0 - 3) | °C |
| 2 | Forward Current | I_F | Variants 01 to 12: 75 Variants 13 to 30: 100 | mA |

TABLE 5(c) - CONDITIONS FOR OPERATING LIFE TESTS

| No. | CHARACTERISTICS | SYMBOL | CONDITIONS | UNIT |
|-----|-----------------------|------------|---|------|
| 1 | Ambient Temperature 1 | T_{amb1} | + 115(+ 0 - 3) | °C |
| 2 | Forward Current 1 | I_{F1} | Variants 01 to 12: 75 Variants 13 to 30: 100 | mA |
| 3 | Ambient Temperature 2 | T_{amb2} | + 125(+ 0 - 3) | °C |
| 4 | Forward Current 2 | I_{F2} | Variants 01 to 12: 75 Variants 13 to 30: 100 | mA |



FIGURE 5(a) - ELECTRICAL CIRCUIT FOR HIGH TEMPERATURE REVERSE BIAS BURN-IN

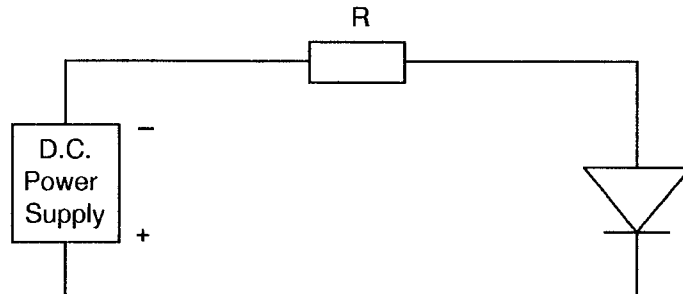
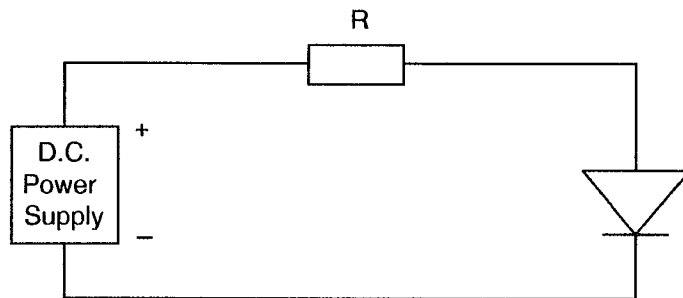

FIGURE 5(b) - ELECTRICAL CIRCUIT FOR POWER BURN-IN AND OPERATING LIFE TESTS





4.8 ENVIRONMENTAL AND ENDURANCE TESTS (CHARTS IV AND V OF ESA/SCC GENERIC SPECIFICATION NO. 5010)

4.8.1 Electrical Measurements on Completion of Environmental Tests

The parameters to be measured on completion of environmental tests are scheduled in Table 2. Unless otherwise stated, the measurements shall be performed at $T_{amb} = +22 \pm 3$ °C.

4.8.2 Electrical Measurements at Intermediate Points and on Completion of Endurance Tests

The parameters to be measured at intermediate points and on completion of endurance tests are scheduled in Table 6. Unless otherwise stated, the measurements shall be performed at $T_{amb} = +22 \pm 3$ °C.

4.8.3 Conditions for Operating Life Tests (Part of Endurance Testing)

The requirements for operating life testing are specified in Section 9 of ESA/SCC Generic Specification No. 5010. The conditions for operating life testing are specified in Table 5(c) of this specification.

4.8.4 Electrical Circuits for Operating Life Tests

The circuit to be used for performance of the operating life test shall be the same as shown in Figure 5(b) for Power Burn-in.

4.9 TOTAL DOSE IRRADIATION TESTING

4.9.1 Application

If specified in Para. 4.2.1 of this specification, total dose irradiation testing shall be performed in accordance with the requirements of ESA/SCC Basic Specification No. 22900.

4.9.2 Bias Conditions

Continuous bias shall be applied during irradiation testing as shown in Figure 6 of this specification.

4.9.3 Electrical Measurements

The parameters to be measured prior to irradiation exposure are scheduled in Table 2 of this specification. Only devices which meet the requirements of Table 2 shall be included in the test sample.

The parameters to be measured during and on completion of irradiation testing are scheduled in Table 7 of this specification.

4.10 SPECIAL TESTING

Not applicable.



TABLE 6 - ELECTRICAL MEASUREMENTS AT INTERMEDIATE POINTS AND ON COMPLETION OF ENDURANCE TESTING

| No. | CHARACTERISTICS | SYMBOL | SPEC. AND/OR TEST METHOD | TEST CONDITIONS | LIMITS | | UNIT |
|-----|-------------------|----------|--------------------------|-----------------|----------------|------|---------|
| | | | | | MIN. | MAX. | |
| 1 | Reverse Current 1 | I_{R1} | As per Table 2 | As per Table 2 | As per Table 2 | | μA |
| 2 | Reverse Current 2 | I_{R2} | As per Table 2 | As per Table 2 | As per Table 2 | | nA |
| 3 | Forward Voltage | V_F | As per Table 2 | As per Table 2 | As per Table 2 | | V |
| 6 | Insertion Loss | IL | As per Table 2 | As per Table 2 | As per Table 2 | | dB |
| 7 | Isolation | ISO | As per Table 2 | As per Table 2 | As per Table 2 | | dB |

FIGURE 6 - BIAS CONDITIONS FOR IRRADIATION TESTING

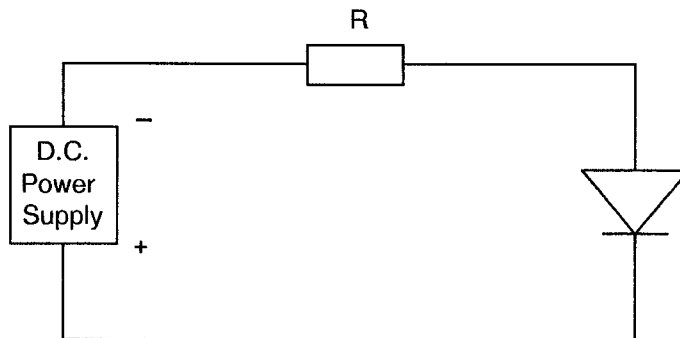

NOTES

1. A reverse bias of half the value of Table 1(b), Item 1, shall be applied.



TABLE 7 - ELECTRICAL MEASUREMENTS DURING AND ON COMPLETION OF IRRADIATION TESTING

| No. | CHARACTERISTICS | SYMBOL | SPEC. AND/OR TEST METHOD | TEST CONDITIONS | CHANGE LIMITS (Δ) | UNIT |
|-----|---------------------------|----------|--------------------------|-----------------|----------------------------|------|
| 6 | Minority Carrier Lifetime | τ_L | As per Table 2 | As per Table 2 | Note 1 | % |

NOTES

1. The graph given below shall be used to determine the maximum permitted change.

