



europaean space agency  
agence spatiale européenne

Pages 1 to 10

**TERMS, DEFINITIONS, ABBREVIATIONS,  
SYMBOLS AND UNITS  
FOR RESISTORS**

**ESA/SCC Basic Specification No. 2134000**



**space components  
coordination group**

Issue/Rev.	Date	Approved by	
		SCCG Chairman	ESA Director General or his Deputy
Issue 1	September 1994	<i>Pommes</i>	<i>Alou</i>



**SCC**

ESA/SCC Basic Specification  
No. 2134000

PAGE 2

ISSUE 1

**DOCUMENTATION CHANGE NOTICE**

Rev. Letter	Rev. Date	Reference	CHANGE Item	Approved DCR No.



**ESC**

ESA/SCC Basic Specification  
No. 2134000

PAGE 3

ISSUE 1

**TABLE OF CONTENTS**

	<u>Page</u>
1. <b><u>SCOPE</u></b>	<b>4</b>
2. <b><u>GENERAL</u></b>	<b>4</b>
2.1 Terms, Definitions and Abbreviations	4
3. <b><u>FIXED RESISTORS</u></b>	<b>5</b>
3.1 Terms, Definitions and Abbreviations	5
3.2 Symbols	6
4. <b><u>VARIABLE RESISTORS</u></b>	<b>6</b>
4.1 Terms, Definitions and Abbreviations	6
4.2 Symbols	10

**1. SCOPE**

This specification forms part of ESA/SCC Basic Specification No. 21300, Terms, Definitions, Abbreviations, Symbols and Units, for resistors, both fixed and variable but excluding resistor networks.

**2. GENERAL****2.1 TERMS, DEFINITIONS AND ABBREVIATIONS**

**Category Temperature Range** - The category temperature range is the range of ambient temperature for which the component is designed to operate continuously; this is defined by the temperature limits of its appropriate category.

**Critical Resistance ( $R_C$ )** - The critical resistance is that resistance value at which the rated voltage is equal to the limiting element voltage. Below the critical resistance, the maximum voltage which may be applied across the terminations of a resistor, at ambient temperature of  $+70^\circ\text{C}$  and below, is the rated voltage. Similarly, above that value, the maximum voltage is the limiting element voltage. At temperatures above  $+70^\circ\text{C}$ , account shall be taken of the derating curve for the resistor.

**Derating Curve** - The derating curve is a curve which shall state the maximum allowable dissipation at temperatures other than  $+70^\circ\text{C}$ .

**Lower Category Temperature** - The lower category temperature is the minimum ambient temperature at which a resistor has been designed to operate continuously.

**Temperature Characteristic of Resistance (TC)** - The temperature characteristic of a resistor is the change in resistance expressed as a percentage occurring between 2 specified ambient temperatures.

$$\text{Temperature characteristic of resistance} = \frac{100\Delta R}{R}$$

where  $\Delta R$  is the change in resistance between 2 specified ambient temperatures.

$R$  is the resistance value at the reference temperature.

**Temperature Coefficient of Resistance** - Temperature dependency of resistance may alternatively be expressed as a temperature coefficient. It must be noted, however, that the use of the term does not imply any degree of linearity for this function, nor should any be assumed.



The temperature coefficient of resistance of a resistor is the mean rate of change of resistance occurring between 2 specified ambient temperatures. It may be expressed either as a percentage or as parts per million, per degree Celsius.

$$\begin{aligned} & \text{Temperature Coefficient} = \frac{\text{Temperature Characteristic of Resistance}}{\Delta t} \\ & \text{(\%/}^\circ\text{C)} \end{aligned}$$

or

$$\begin{aligned} & \text{Temperature Coefficient} = 10\,000 \times \frac{\text{Temperature Characteristic of Resistance}}{\Delta t} \\ & \text{(ppm/}^\circ\text{C)} \end{aligned}$$

where  $\Delta t$  is the algebraic difference in degrees Celsius between the reference temperature and the other specified ambient temperature.

Upper Category Temperature

- The upper category temperature is the maximum ambient temperature for which a resistor has been designed to operate continuously at that portion of the rated dissipation which is indicated in the category dissipation.

### 3. FIXED RESISTORS

#### 3.1 TERMS, DEFINITIONS AND ABBREVIATIONS

Isolation Voltage ( $U_i$ )  
(applicable only to insulated resistors)

- The isolation voltage is the maximum peak voltage which may be applied under continuous operating conditions between any of the resistor terminations and any conducting mounting surface. The value of the isolation voltage shall be not less than 1.42 times the limiting element voltage.

Limiting Element Voltage ( $U_L$ )

- The limiting element voltage is the maximum d.c. or a.c. r.m.s. voltage that may be applied to the terminations of a resistor when the rated resistance is equal to, or greater than, the critical resistance.

Where the term "a.c. r.m.s. voltage" is used in the ESA/SCC specifications, the peak voltage shall not exceed 1.42 times the r.m.s. value.

Rated Dissipation ( $P_n$ )

- The rated dissipation of a fixed resistor is the maximum allowable dissipation at an ambient temperature of  $+70^\circ\text{C}$  under the conditions of the life test and which will result in a change in resistance not greater than that specified for this endurance test.

Rated Resistance ( $R_n$ )

- The rated resistance of a fixed resistor is the value which is marked on the resistor.



Rated Voltage ( $U_R$ )

- The rated voltage is the d.c. or a.c. r.m.s. voltage calculated from the square root of the product of the rated resistance and the rated dissipation.

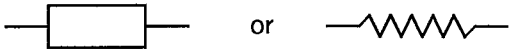

Voltage Coefficient of Resistance - The voltage coefficient of resistance is defined as the reversible change in resistance with applied voltage. It is expressed in percent resistance per applied volt.

### 3.2 SYMBOLS

SYMBOL	DESCRIPTION
	Resistor, general symbol (if it is not necessary to specify whether it is reactive or not)
	Non-reactive resistor

## 4. VARIABLE RESISTORS

### 4.1 TERMS, DEFINITIONS AND ABBREVIATIONS

Category Dissipation - The category dissipation is a fraction of the rated dissipation exactly defined in the Detail Specifications applicable at the upper category temperature, taking account of the derating curve given in the Detail Specification.

**N.B.**

The category dissipation may be 0.

Conformity - The degree of conformity, expressed as a percentage, is the maximum deviation of the actual from the theoretical resistance when these are expressed as percentages of the effective resistance.

**N.B.**

Conformity may be expressed in terms of voltage ratios.

Cycle of Operation - A cycle of operation is the travel of the moving contact from one end of the resistance element to the other and back.

Designation of Terminations - The preferred designation of the 3 terminations of a variable resistor (see Para. 4.2) is:-

(a) The end termination electrically nearest to the moving contact with the spindle set fully anti-clockwise as defined in the definition of "Direction of Rotation".

(b) The termination of the moving contact.

(c) The other end termination.



The numerals 1, 2 and 3, or colours yellow, red and green, may be used as alternatives to (a), (b) and (c) respectively. Where terminations are marked, the marking shall be in accordance with this clause.

**Direction of Rotation**

- Rotation is defined as clockwise or anti-clockwise when viewing the face of the variable resistor which includes the means of actuation. Where doubt exists, the reference face shall be marked in accordance with the Detail Specification.

**Effective Electrical Travel  
(Angle of Effective Rotation)**

- The effective electrical travel is the value of the movement of the actuating device necessary to move the moving contact in such a manner that the resistance changes as prescribed by the declared resistance law.

**N.B.**

For some constructions of variable resistor, the effective electrical travel may be the same as the total electrical travel.

**Effective Resistance**

- That portion of the total resistance over which the resistance changes in the manner prescribed by the declared resistance law.

**Element Resistance (R)**

- The element resistance is the resistance between terminations (a) and (c) when measured as described in the Generic Specification.

**Ineffective Mechanical Travel  
(Angle of Ineffective Rotation)**

- Ineffective mechanical travel is that part of the mechanical travel where the continuity between the moving contact and the resistance element cannot be guaranteed and is equal to the difference between the total mechanical travel and the total electrical travel.

**Isolation Voltage**

- The isolation voltage is the maximum peak voltage under continuous operating conditions which may be applied between the potentiometer terminations and other external conducting parts connected together. The value of the isolation voltage shall be not less than 1.42 times the limiting element voltage, at normal air pressure. Under conditions of low air pressure, the value of the isolation voltage will be less and will be given in the Detail Specification.

**Limiting Element Voltage ( $U_L$ )**

- The limiting element voltage is the maximum d.c. or a.c. r.m.s. voltage which may be applied across the element of a variable resistor.

Where the term a.c. r.m.s. voltage is used in a specification, the peak voltage shall not exceed 1.45 times the r.m.s. value (see definitions of "Critical Resistance" and "Rated Voltage").



- Limiting Slider Current ( $I_n$ ) - The limiting slider current is the maximum current that may be passed between the resistance element and the moving contact. The value shall be stated in the relevant Detail Specification.
- Linearity - The specific type of conformity where the theoretical law or the voltage ratio is shown as a straight line.
- Minimum Effective Resistance - The resistance value, at each end of the effective electrical travel, between termination (b) and the nearer end termination (a) or (c).
- Output Ratio - The ratio of the output voltage (e) to the total applied voltage (E).
- Output Smoothness - Output smoothness is any spurious variation in the electrical output not present in the input. It is expressed as a percentage of the total applied voltage and measured for specified travel increments over the effective electrical travel. Output smoothness includes effects of contact resistance variations, resolution and other micro non-linearities in the output.
- Output Voltage (e) - The voltage between terminations (b) and the specified reference point. Unless otherwise stated, the specified reference point is termination (a).
- Rated Dissipation ( $P_n$ ) - The maximum allowable dissipation between terminations (a) and (c) (see Para. 4.2) of a variable resistor at an ambient temperature of  $+70^\circ\text{C}$  under conditions of the electrical operating life test at  $+70^\circ\text{C}$  which will result in a change in resistance not greater than that specified for that test.

**N.B.**

In practice, the dissipation is modified by the following conditions:-

- (a) For high values of resistance, the limiting element voltage may prevent the rated dissipation being attained.
- (b) For the dissipation at temperatures other than  $+70^\circ\text{C}$ , reference should be made to the rating graphs in Para. 4.2 or the relevant Detail Specification.
- (c) For situations where only terminations (a) and (b), or (b) and (c) are being used and the control spindle is set at an angle less than 100% of the angle of effective rotation. In this case, the limiting slider current should also be taken into account (see definition of "Limiting Slider Current").

- Rated Resistance ( $R_n$ ) - The rated resistance is the resistance value marked on the variable resistor.



**Rated Voltage ( $U_n$ )**

- The rated voltage is that d.c. or a.c. r.m.s. voltage calculated from the square root of the product of the rated resistance and the rated dissipation.

**N.B.**

At high values of resistance, the rated voltage may not be applicable because of the size and construction of the potentiometer (see definitions of "Critical Resistance" and "Limiting Element Voltage").

**Residual Resistance**

- The residual resistance is the resistance obtained between the end termination (a) or (c) and the termination of the moving contact (b) when the moving contact is set against one of the end stops (see definition of "Designation of Terminations").

Where there is no sharp change in resistance between the end stop and the point where the minimum effective resistance is observed, the residual resistance, the terminal resistance and the minimum effective resistance become the same. The lowest resistance value need not correspond with the mechanical end stop.

**Resistance Law**

- The relationship of the effective resistance value between terminations (a) and (b) or of the output ratio  $U_{ab} \div U_{ac}$  to the mechanical position of the moving contact. Common potentiometer laws are classified as follows:-

(a) Linear law: Law A.

(b) Logarithmic law: Law B.

(c) Reversed logarithmic law: Law C.

The Detail Specification may permit and prescribe the tolerances for a rate of change in resistance near to the end of the effective rotation less than that required by the prescribed law. It may also permit and prescribe the tolerance for approximations to the prescribed law. Laws other than the widely used laws A, B and C (for example, sine or co-sine) may be required for special applications. The law will then be prescribed in the Detail Specification.

**Terminal Resistance ( $R_T$ )**

- Terminal resistance is the minimum resistance which can be obtained between the termination connected to the moving contact (b) and any other termination (see definition of "Designation of Terminations").

**Total Applied Voltage (E)**

- The voltage applied between input terminations, e.g. the voltage applied between input terminations (a) and (c).

**Total Electrical Travel**

- The total electrical travel is the value of the movement of the actuating device between 2 end positions (defined in the Detail Specification) during which there should not normally be any interruption in contact between the moving contact and the resistance element.

**N.B.**

The end positions usually coincide with the end stops or the positions at which the declutching device operates, and the total electrical travel is therefore the same as the total mechanical travel.

**Total Mechanical Travel  
(Total Mechanical Rotation)**

- The total mechanical travel is the value of the movement of the actuating device while the moving contact traverses the whole of its function between the 2 end stops or the 2 positions at which the declutching device operates.

4.2 **SYMBOLS**

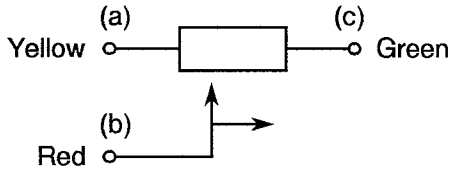
SYMBOL	DESCRIPTION
	<p style="text-align: center;">Variable resistor</p>

**NOTES**

1. See Para. 4.1, Designation of Terminations.