



european space agency
agence spatiale européenne

Pages 1 to 31

**INTEGRATED CIRCUITS, SILICON MONOLITHIC,
BIPOLAR OPERATIONAL AMPLIFIERS,
BASED ON TYPE LM11**

ESA/SCC Detail Specification No. 9101/022



**space components
coordination group**

Issue/Rev.	Date	Approved by	
		SCCG Chairman	ESA Director General or his Deputy
Issue 1	March 1987		
Revision 'A'	December 1991	<i>Pommes</i>	<i>J. Leber</i>



DOCUMENTATION CHANGE NOTICE

Rev. Letter	Rev. Date	Reference	CHANGE Item	Approved DCR No.
'A'	Dec. '91	P1. Cover page P2. DCN P3. T of C P6. Table 1(a) Table 1(b) P7. Figure 1 P11. Para. 4.2.2 P12. Para. 4.2.4 Para. 4.2.5 Para. 4.3.3 P13. Para. 4.4.2	: Para. 4.3.3 deleted : Variant 03 added : No. 5, Characteristics amended : Note deleted : Deviation deleted, "None." added : Deviation deleted, "None." added : Deviation deleted, "None." added : Paragraph deleted : Paragraph amended	None None None 22913 22913 22913 21048 22919 22919 22921 22913
		This specification has been transferred from hardcopy to electronic format. The content is unchanged but minor differences in presentation exist.		



TABLE OF CONTENTS

	<u>Page</u>
1. GENERAL	5
1.1 Scope	5
1.2 Type Variants	5
1.3 Maximum Ratings	5
1.4 Parameter Derating Information	5
1.5 Physical Dimensions	5
1.6 Pin Assignment	5
1.7 Truth Table	5
1.8 Circuit Schematic	5
1.9 Functional Diagram	5
2. APPLICABLE DOCUMENTS	11
3. TERMS, DEFINITIONS, ABBREVIATIONS, SYMBOLS AND UNITS	11
4. REQUIREMENTS	11
4.1 General	11
4.2 Deviations from Generic Specification	11
4.2.1 Deviations from Special In-process Controls	11
4.2.2 Deviations from Final Production Tests (Chart II)	11
4.2.3 Deviations from Burn-in Tests (Chart III)	12
4.2.4 Deviations from Qualification, Environmental and Endurance Tests (Chart IV)	12
4.2.5 Deviations from Lot Acceptance Tests (Chart V)	12
4.3 Mechanical Requirements	12
4.3.1 Dimension Check	12
4.3.2 Weight	12
4.4 Materials and Finishes	12
4.4.1 Case	12
4.4.2 Lead Material and Finish	13
4.5 Marking	13
4.5.1 General	13
4.5.2 Lead Identification	13
4.5.3 The SCC Component Number	13
4.5.4 Traceability Information	13
4.5.5 Marking of Small Components	14
4.6 Electrical Measurements	14
4.6.1 Electrical Measurements at Room Temperature	14



	<u>Page</u>
4.6.2 Electrical Measurements at High and Low Temperatures	14
4.6.3 Circuits for Electrical Measurements	14
4.7 Burn-in Tests	14
4.7.1 Parameter Drift Values	14
4.7.2 Conditions for Burn-in	15
4.7.3 Electrical Circuits for Burn-in	15
4.8 Environmental and Endurance Tests	30
4.8.1 Electrical Measurements on Completion of Environmental Tests	30
4.8.2 Electrical Measurements at Intermediate Points During Endurance Tests	30
4.8.3 Electrical Measurements on Completion of Endurance Tests	30
4.8.4 Conditions for Operating Life Tests	30
4.8.5 Electrical Circuits for Operating Life Tests	30
4.8.6 Conditions for High Temperature Storage Test	30

TABLES

1(a) Type Variants	6
1(b) Maximum Ratings	6
2 Electrical Measurements at Room Temperature - d.c. Parameters	16
2 Electrical Measurements at Room Temperature - a.c. Parameters	18
3(a) Electrical Measurements at High Temperature	19
3(b) Electrical Measurements at Low Temperature	21
4 Parameter Drift Values	29
5 Conditions for Burn-in	29
6 Electrical Measurements on Completion of Environmental Tests and at Intermediate Points and on Completion of Endurance Testing	31

FIGURES

1 Device Dissipation Derating with Temperature	7
2 Physical Dimensions	8
3(a) Pin Assignment	9
3(b) Truth Table	N/A
3(c) Circuit Schematic	9
3(d) Functional Diagram	10
4(a) Input Offset Voltage	23
4(b) Input Offset Current	23
4(c) Input (Plus) Bias Current	24
4(d) Input (Minus) Bias Current	24
4(e) Supply Current	25
4(f) Short Circuit Output Current	25
4(g) Open Loop Voltage Gain	26
4(h) Power Supply Rejection Ratio	26
4(i) Common Mode Rejection Ratio	27
4(j) Dynamic Test Measurement Circuit	28
5 Electrical Circuit for Burn-in	29

APPENDICES (Applicable to specific Manufacturers only)

None.

**1. GENERAL****1.1 SCOPE**

This specification details the ratings, physical and electrical characteristics, test and inspection data for a silicon monolithic, bipolar operational amplifier, based on Type LM11. It shall be read in conjunction with ESA/SCC Generic Specification No. 9000, the requirements of which are supplemented herein.

1.2 TYPE VARIANTS

Variants of the basic type integrated circuits specified herein, which are also covered by this specification, are given in Table 1(a).

1.3 MAXIMUM RATINGS

The maximum ratings, which shall not be exceeded at any time during use or storage, applicable to the integrated circuits specified herein, are as scheduled in Table 1(b).

1.4 PARAMETER DERATING INFORMATION

As per Figure 1.

1.5 PHYSICAL DIMENSIONS

As per Figure 2.

1.6 PIN ASSIGNMENT

As per Figure 3(a).

1.7 TRUTH TABLE (FIGURE 3(b))

Not applicable.

1.8 CIRCUIT SCHEMATIC

As per Figure 3(c).

1.9 FUNCTIONAL DIAGRAM

As per Figure 3(d).

**TABLE 1(a) - TYPE VARIANTS**

VARIANT	CASE	FIGURE	LEAD MATERIAL AND FINISH
-01	TO99	2	D2
-02	TO99	2	D3 or D4
-03	TO99	2	D9

TABLE 1(b) - MAXIMUM RATINGS

No.	CHARACTERISTICS	SYMBOL	MAXIMUM RATINGS	UNITS	REMARKS
1	Supply Voltage Range	V_S	± 20	V	
2	Differential Input Voltage Range	V_{ID}	± 30	V	Note 1
3	Input Voltage Range	V_I	± 15	V	Note 2
4	Input Current Range	I_I	-0.1 to +10	mA	
5	Device Power Dissipation	P_D	500	mW	Note 3
6	Output Short Circuit Duration		Indefinite		Note 4
7	Operating Temperature Range	T_{amb}	-55 to +125	°C	
8	Storage Temperature Range	T_{stg}	-55 to +150	°C	
9	Soldering Temperature	T_{sol}	+300	°C	Note 5
10	Junction Temperature	T_J	+150	°C	

NOTES

1. The inputs are shunted with back-to-back diodes for overvoltage protection. Therefore, excessive current will flow if a differential voltage in excess of 1.0V is applied between the inputs, unless some limiting resistance is used.
2. If the supply voltage is less than +15V, the maximum input voltage is equal to the supply voltage.
3. Derate above $T_{amb} = +75^\circ\text{C}$ at 6.60mW/°C.
4. Continuous short circuit is allowed for an ambient temperature of +70°C and a case temperature of +125°C.
5. Duration: ≤ 5 seconds.



FIGURE 1 - DEVICE DISSIPATION DERATING WITH TEMPERATURE

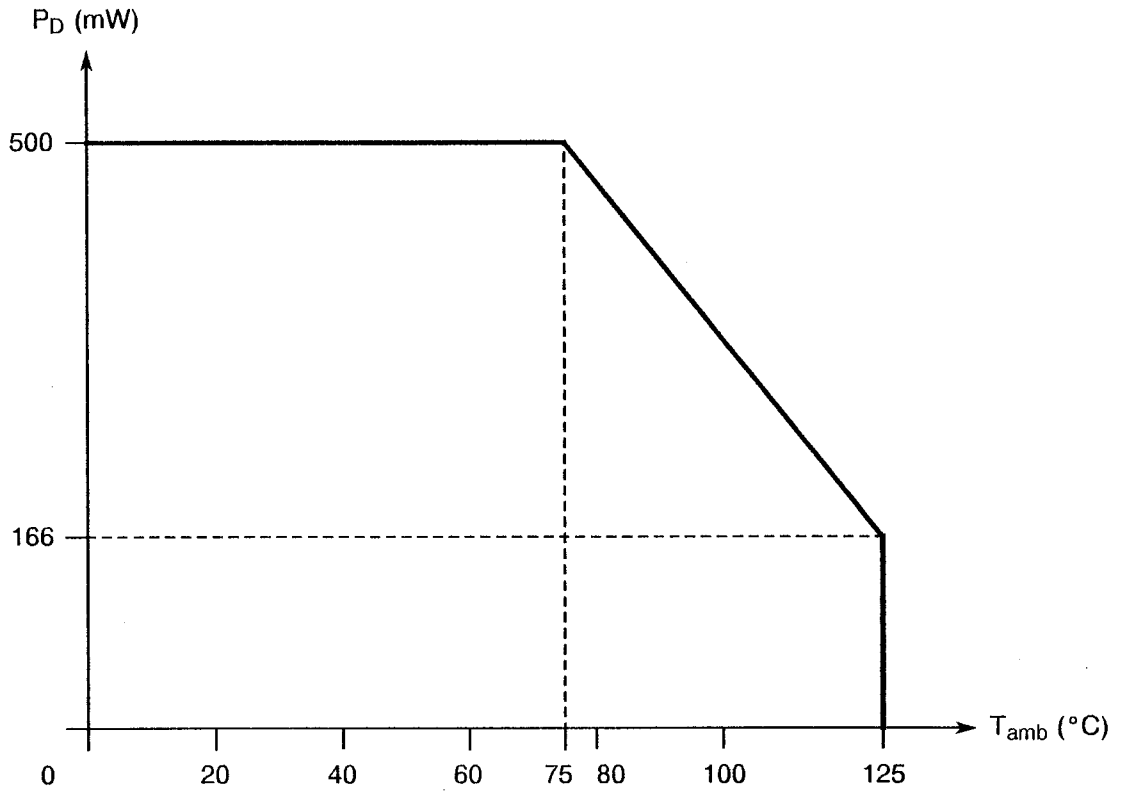
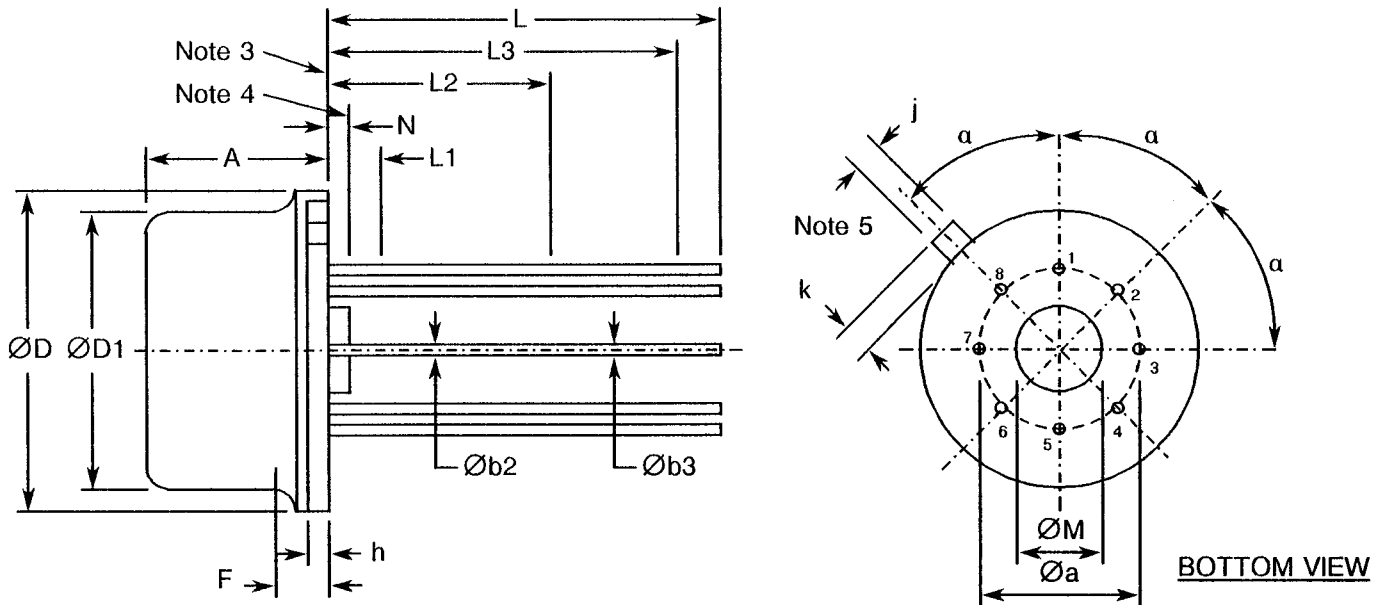



FIGURE 2 - PHYSICAL DIMENSIONS

TO99 PACKAGE



SYMBOL	MILLIMETRES			INCHES			DEGR. NOM.	NOTES
	MIN.	NOM.	MAX.	MIN.	NOM.	MAX.		
Øa	-	5.08 (*)	-	-	0.200 (*)	-		1
A	4.20	-	4.69	0.165	-	0.185		
Øb2	0.407	-	0.508	0.016	-	0.020		
Øb3	-	-	0.53	-	-	0.021		
ØD	8.51	-	9.39	0.335	-	0.370		
ØD1	7.75	-	8.50	0.305	-	0.335		
F	-	-	1.27	-	-	0.050		
h	0.15	-	1.01	0.006	-	0.040		
j	0.712	-	0.863	0.028	-	0.034		
k	0.74	-	1.14	0.029	-	0.045		2
L	12.50	-	14.50	0.492	-	0.071		
L1	-	-	1.27	-	-	0.050		
L2	6.35	-	-	0.250	-	-		
L3	12.70	-	-	0.500	-	-		
ØM	3.56	-	4.06	0.140	-	0.160		
N	0.26	-	1.01	0.010	-	0.040		
α							45° (*)	1

NOTES

- The section of each terminal, from a distance of 1.37mm (0.054 inch) to the reference plane, shall be located in a ring whose diameter is 0.99mm (0.039 inch), centred on the accurate geometrical point defining the terminal axis.
- Measured from the D diameter.
- Reference plane.
- Base plane.
- Reference index of Pin 8.

* = accurate geometrical location.

The metric dimensions are calculated from the original dimensions in inches.



FIGURE 3(a) - PIN ASSIGNMENT

TO-99 PACKAGE

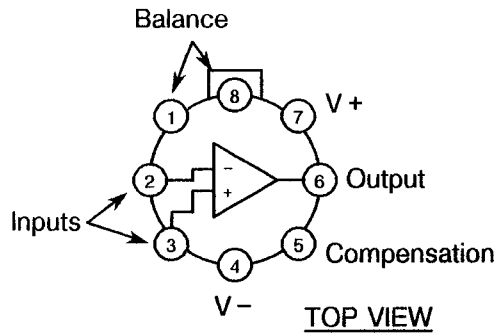

NOTES

- 1. Pin 4 connected to case.

FIGURE 3(b) - TRUTH TABLE

Not applicable.

FIGURE 3(c) - CIRCUIT SCHEMATIC (FOR INFORMATION ONLY)

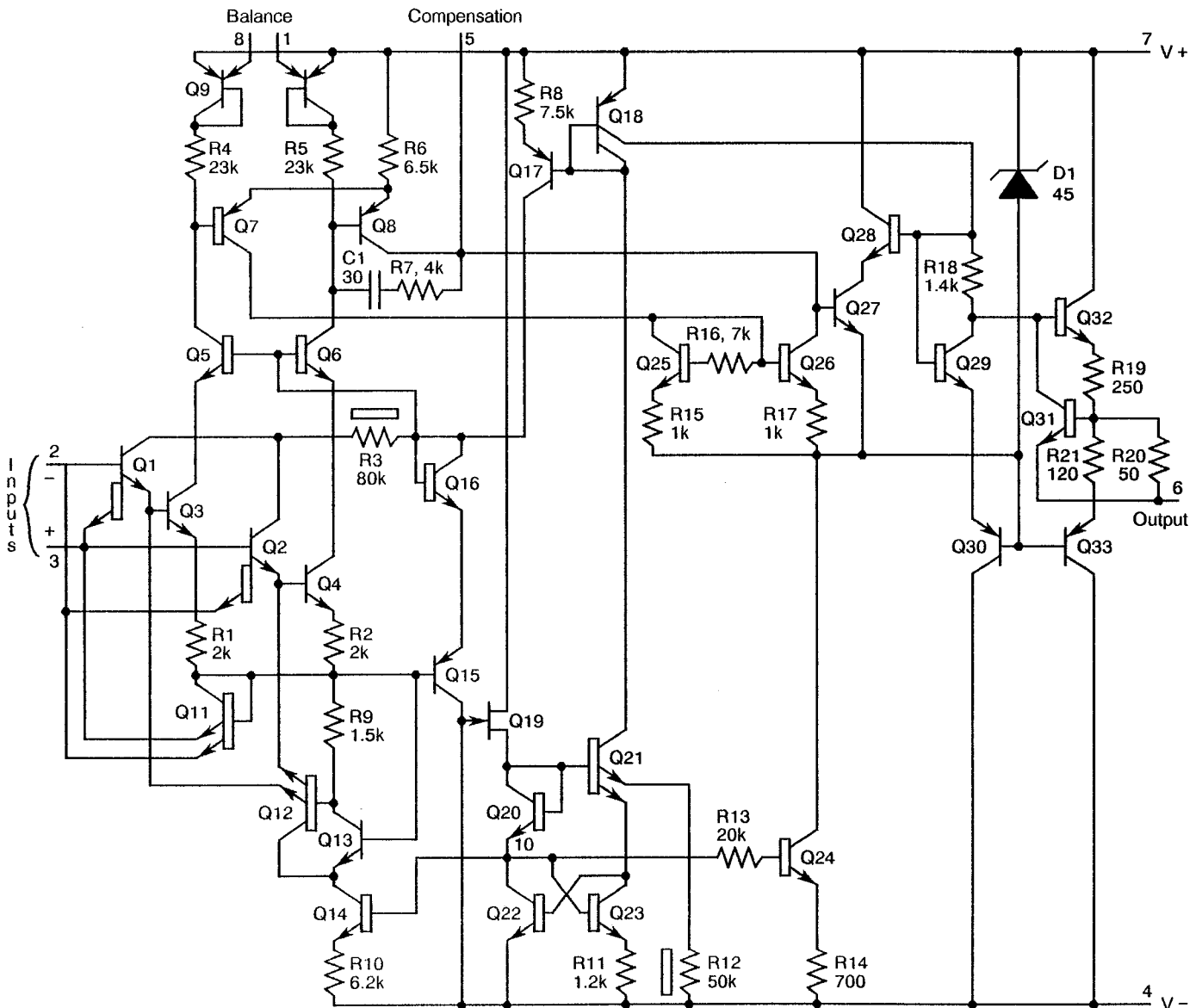
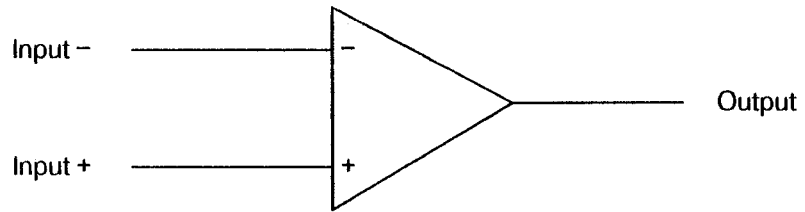



FIGURE 3(d) - FUNCTIONAL DIAGRAM



**SCC**ESA/SCC Detail Specification
No. 9101/022

Rev. 'A'

PAGE 11

ISSUE 1

2. APPLICABLE DOCUMENTS

The following documents form part of this specification and shall be read in conjunction with it:-

- (a) ESA/SCC Generic Specification No. 9000 for Integrated Circuits.
- (b) MIL-STD-883, Test Methods and Procedures for Micro-electronics.

3. TERMS, DEFINITIONS, ABBREVIATIONS, SYMBOLS AND UNITS

For the purpose of this specification, the terms, definitions, abbreviations, symbols and units specified in ESA/SCC Basic Specification No. 21300 shall apply. In addition, the following abbreviations are used:-

- OS = Overshoot.
- I_{OS} = Output Short Circuit Current.
- I_{CC} = Supply Current.

4. REQUIREMENTS**4.1 GENERAL**

The complete requirements for procurement of the integrated circuits specified herein are stated in this specification and ESA/SCC Generic Specification No. 9000 for Integrated Circuits. Deviations from the Generic Specification applicable to this specification only, are listed in Para. 4.2.

Deviations from the applicable Generic Specification and this Detail Specification, formally agreed with specific Manufacturers on the basis that the alternative requirements are equivalent to the ESA/SCC requirements and do not affect the components' reliability, are listed in the appendices attached to this specification.

4.2 DEVIATIONS FROM GENERIC SPECIFICATION**4.2.1 Deviations from Special In-process Controls**

None.

4.2.2 Deviations from Final Production Tests (Chart II)

None.

**4.2.3 Deviations from Burn-in Tests (Chart III)**

Subpara. 7.1.1(a), "High Temperature Reverse Bias" test and subsequent electrical measurements related to this test shall be omitted.

4.2.4 Deviations from Qualification, Environmental and Endurance Tests (Chart IV)

None.

4.2.5 Deviations from Lot Acceptance Tests (Chart V)

None.

4.3 MECHANICAL REQUIREMENTS**4.3.1 Dimension Check**

The dimensions of the integrated circuits specified herein shall be checked. They shall conform to those shown in Figure 2.

4.3.2 Weight

The maximum weight of the integrated circuits specified herein shall be 1.5 grammes.

4.4 MATERIALS AND FINISHES

The materials and finishes shall be as specified herein. Where a definite material is not specified, a material which will enable the integrated circuits specified herein to meet the performance requirements of this specification shall be used. Acceptance or approval of any constituent material does not guarantee acceptance of the finished product.

4.4.1 Case

The case shall be hermetically sealed and have a metal body with hard glass seals and the lids shall be welded.



4.4.2 Lead Material and Finish

The lead material shall be Type 'D' with either Type '2', Type '3 or 4' or Type '9' finish in accordance with ESA/SCC Basic Specification No. 23500. (See Table 1(a) for Type Variants).

4.5 MARKING

4.5.1 General

The marking of components delivered to this specification shall be in accordance with ESA/SCC Basic Specification No. 21700. Each component shall be marked in respect of:-

- (a) Lead Identification.
- (b) The SCC Component Number.
- (c) Traceability Information.

4.5.2 Lead Identification

An index shall be located at the top of the package in the position defined in Note 5 to Figure 2. Alternatively, a tab shall be used to identify Pin No. 1. The pin numbering shall be read with the index or tab on the left-hand side.

4.5.3 The SCC Component Number

Each component shall bear the SCC Component Number which shall be constituted and marked as follows:

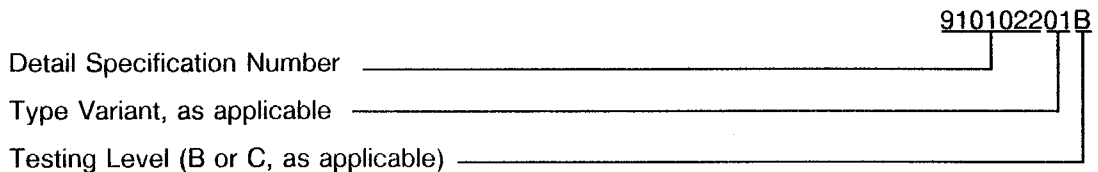

4.5.4 Traceability Information

Each component shall be marked in respect of traceability information in accordance with ESA/SCC Basic Specification No. 21700.



4.5.5 Marking of Small Components

When it is considered that the component is too small to accommodate the marking as specified above, as much as space permits shall be marked. The order of precedence shall be as follows:-

- (a) Lead Identification.
- (b) The SCC Component Number.
- (c) Traceability Information.

The marking information in full shall accompany each component in its primary package.

4.6 ELECTRICAL MEASUREMENTS

4.6.1 Electrical Measurements at Room Temperature

The parameters to be measured in respect of electrical characteristics are scheduled in Table 2. Unless otherwise specified, the measurements shall be performed at $T_{amb} = +22 \pm 3$ °C.

4.6.2 Electrical Measurements at High and Low Temperatures

The parameters to be measured at high and low temperatures are scheduled in Tables 3(a) and 3(b). The measurements shall be performed at $T_{amb} = +125(+0-5)$ and $-55(+5-0)$ °C respectively.

4.6.3 Circuits for Electrical Measurements

Circuits for use in performing the electrical measurements listed in Tables 2 and 3 of this specification are shown in Figure 4.

4.7 BURN-IN TESTS

4.7.1 Parameter Drift Values

The parameter drift values applicable to burn-in are specified in Table 4 of this specification. Unless otherwise stated, measurements shall be performed at $T_{amb} = +22 \pm 3$ °C. The parameter drift values (Δ) applicable to the parameters scheduled, shall not be exceeded. In addition to these drift value requirements, the appropriate limit value specified for a given parameter in Table 2 shall not be exceeded.



4.7.2 Conditions for Burn-in

The requirements for burn-in are specified in Section 7 of ESA/SCC Generic Specification No. 9000. The conditions for burn-in shall be as specified in Table 5 of this specification.

4.7.3 Electrical Circuits for Burn-in

Circuits for use in performing the burn-in tests are shown in Figure 5 of this specification.

**TABLE 2 - ELECTRICAL MEASUREMENTS AT ROOM TEMPERATURE - d.c. PARAMETERS**

No.	Characteristics	Symbol	Test Method MIL-STD 883	Test Fig.	Meas'd Value	Test Conditions	Limits		Unit
							Min	Max	
1	Input Offset Voltage	V_{IO1}	4001	4(a)	E_1 (V)	$+V_{CC} = 20V, -V_{CC} = -20V$ $V_{IN} = 0V$	-	0.3	mV
2	Input Offset Voltage	V_{IO2}	4001	4(a)	E_2 (V)	$+V_{CC} = 2.5V, -V_{CC} = -2.5V$ $V_{IN} = 0V$	-	0.3	mV
3	Input Offset Current	I_{IO1}	4001	4(b)	E_3 (V)	$+V_{CC} = 20V, -V_{CC} = -20V$ $C_S = 10nF, V_{IN} = 0V$	-	10	pA
4	Input Offset Current	I_{IO2}	4001	4(b)	E_4 (V)	$+V_{CC} = 2.5V, -V_{CC} = -2.5V$ $C_S = 10nF, V_{IN} = 0V$	-	10	pA
5	Input (Plus) Bias Current	I_{+IB1}	4001	4(c)	E_5 (V)	$+V_{CC} = 20V, -V_{CC} = -20V$ $C_S = 10nF, V_{IN} = 0V$	-	50	pA
6	Input (Plus) Bias Current	I_{+IB2}	4001	4(c)	E_6 (V)	$+V_{CC} = 2.5V, -V_{CC} = -2.5V$ $C_S = 10nF, V_{IN} = 0V$	-	50	pA
7	Input (Minus) Bias Current	I_{-IB1}	4001	4(d)	E_7 (V)	$+V_{CC} = 20V, -V_{CC} = -20V$ $C_S = 10nF, V_{IN} = 0V$	-	50	pA
8	Input (Minus) Bias Current	I_{-IB2}	4001	4(d)	E_8 (V)	$+V_{CC} = 2.5V, -V_{CC} = -2.5V$ $C_S = 10nF, V_{IN} = 0V$	-	50	pA
9	Power Supply Current	I_{CC}	4005	4(e)	I_{CC}	$+V_{CC} = 20V, -V_{CC} = -20V$	-	0.6	mA
10	Short Circuit Output Current (Plus)	$I_{OS(+)}$	3011	4(f)	I_{OS}	$+V_{CC} = 15V, -V_{CC} = -15V$ $V_{IN} = -15V$ Note 1	-15	-	mA
11	Short Circuit Output Current (Minus)	$I_{OS(-)}$	3011	4(f)	I_{OS}	$+V_{CC} = 15V, -V_{CC} = -15V$ $V_{IN} = +15V$ Note 1	-	15	mA
12	Open Loop Voltage Gain (Plus)	$+A_{VS}$	4004	4(g)	E_9 (V)	$+V_{CC} = 15V, -V_{CC} = -15V$ $V_{IN} = -12V, I_{OUT} = -2.0mA$	100	-	V/mV
13	Open Loop Voltage Gain (Minus)	$-A_{VS}$	4004	4(g)	E_{10} (V)	$+V_{CC} = 15V, -V_{CC} = -15V$ $V_{IN} = +12V, I_{OUT} = 2.0mA$	100	-	V/mV
14	Open Loop Voltage Gain (Plus)	$+A_{VS}$	4004	4(g)	E_{11} (V)	$+V_{CC} = 15V, -V_{CC} = -15V$ $V_{IN} = -12V, I_{OUT} = -0.5mA$	250	-	V/mV
15	Open Loop Voltage Gain (Minus)	$-A_{VS}$	4004	4(g)	E_{12} (V)	$+V_{CC} = 15V, -V_{CC} = -15V$ $V_{IN} = +12V, I_{OUT} = +0.5mA$	250	-	V/mV

NOTES: See Page 18.



TABLE 2 - ELECTRICAL MEASUREMENTS AT ROOM TEMPERATURE - d.c. PARAMETERS (CONT'D)

No.	Characteristics	Symbol	Test Method MIL-STD 883	Test Fig.	Meas'd Value	Test Conditions	Limits		Unit
							Min	Max	
16	Power Supply Rejection Ratio (Plus)	+ PSRR	4003	4(h)	E ₁₃ (V)	+ V _{CC} = 2.5V, - V _{CC} = - 20V V _{IN} = 0V	100	-	dB
17	Power Supply Rejection Ratio (Minus)	- PSRR	4003	4(h)	E ₁₄ (V)	+ V _{CC} = 20V, - V _{CC} = - 2.5V V _{IN} = 0V	100	-	dB
18	Common Mode Rejection Ratio	CMRR	4003	4(i)	E ₁₅ (V)	+ V _{CC} = 28V, - V _{CC} = - 2.0V V _{IN} = - 13V	110	-	dB
19	Common Mode Rejection Ratio	CMRR	4003	4(i)	E ₁₆ (V)	+ V _{CC} = 1.0V, - V _{CC} = - 29V V _{IN} = 14V	110	-	dB

NOTES: See Page 18.

**TABLE 2 - ELECTRICAL MEASUREMENTS AT ROOM TEMPERATURE - a.c. PARAMETERS**

No.	Characteristics	Symbol	Test Method MIL-STD 883	Test Fig.	Test Conditions	Limits		Unit
						Min	Max	
22	Slew Rate (Plus)	SR(+)	4002	4(j)	+V _{CC} = ±20V V _{IN} = -5.0k to +5.0V square R _L = 10k Note 2	0.1	-	V/μs
23	Slew Rate (Minus)	SR(-)	4002	4(j)	V _{CC} = ±20V V _{IN} = -5.0k to +5.0V square R _L = 10k Note 2	0.1	-	V/μs
24	Rise Time	RT	4002	4(j)	V _{CC} = ±20V V _{IN} = 50mV R _L = 10k Note 2	-	1000	ns
25	Overshoot	OS	4002	4(j)	V _{CC} = ±20V V _{IN} = 50mV R _L = 10k Note 2	-	40	%

NOTES

1. For sampling inspections and end-point tests, the duration of measurement of I_{OS} shall be 5 seconds minimum.

For other tests, this duration may be reduced to be consistent with automatic test procedures provided that the same limits are maintained.

2. Sample Test Inspection Level = II; AQL = 2.5%.

**TABLE 3(a) - ELECTRICAL MEASUREMENTS AT HIGH TEMPERATURE, +125(+0-5) °C**

No.	Characteristics	Symbol	Test Method MIL-STD 883	Test Fig.	Meas'd Value	Test Conditions	Limits		Unit
							Min	Max	
1	Input Offset Voltage	V_{IO1}	4001	4(a)	E_1 (V)	$+V_{CC} = 20V, -V_{CC} = -20V$ $V_{IN} = 0V$	-	0.6	mV
2	Input Offset Voltage	V_{IO2}	4001	4(a)	E_2 (V)	$+V_{CC} = 2.5V, -V_{CC} = -2.5V$ $V_{IN} = 0V$	-	0.6	mV
3	Input Offset Current	I_{IO1}	4001	4(b)	E_3 (V)	$+V_{CC} = 20V, -V_{CC} = -20V$ $C_S = 10nF, V_{IN} = 0V$	-	30	pA
4	Input Offset Current	I_{IO2}	4001	4(b)	E_4 (V)	$+V_{CC} = 2.5V, -V_{CC} = -2.5V$ $C_S = 10nF, V_{IN} = 0V$	-	30	pA
5	Input (Plus) Bias Current	I_{+IB1}	4001	4(c)	E_5 (V)	$+V_{CC} = 20V, -V_{CC} = -20V$ $C_S = 10nF, V_{IN} = 0V$	-	150	pA
6	Input (Plus) Bias Current	I_{+IB2}	4001	4(c)	E_6 (V)	$+V_{CC} = 2.5V, -V_{CC} = -2.5V$ $C_S = 10nF, V_{IN} = 0V$	-	150	pA
7	Input (Minus) Bias Current	I_{-IB1}	4001	4(d)	E_7 (V)	$+V_{CC} = 20V, -V_{CC} = -20V$ $C_S = 10nF, V_{IN} = 0V$	-	150	pA
8	Input (Minus) Bias Current	I_{-IB2}	4001	4(d)	E_8 (V)	$+V_{CC} = 2.5V, -V_{CC} = -2.5V$ $C_S = 10nF, V_{IN} = 0V$	-	150	pA
9	Power Supply Current	I_{CC}	4005	4(e)	I_{CC}	$+V_{CC} = 20V, -V_{CC} = -20V$	-	0.8	mA
10	Short Circuit Output Current (Plus)	$I_{OS(+)}$	3011	4(f)	I_{OS}	$+V_{CC} = 15V, -V_{CC} = -15V$ $V_{IN} = -15V$ Note 1	-15	-	mA
11	Short Circuit Output Current (Minus)	$I_{OS(-)}$	3011	4(f)	I_{OS}	$+V_{CC} = 15V, -V_{CC} = -15V$ $V_{IN} = +15V$ Note 1	-	15	mA
12	Open Loop Voltage Gain (Plus)	$+A_{VS}$	4004	4(g)	E_9 (V)	$+V_{CC} = 15V, -V_{CC} = -15V$ $V_{IN} = -12V, I_{OUT} = -2.0mA$	50	-	V/mV
13	Open Loop Voltage Gain (Minus)	$-A_{VS}$	4004	4(g)	E_{10} (V)	$+V_{CC} = 15V, -V_{CC} = -15V$ $V_{IN} = +12V, I_{OUT} = 2.0mA$	50	-	V/mV

NOTES: See Page 18.



TABLE 3(a) - ELECTRICAL MEASUREMENTS AT HIGH TEMPERATURE, +125(+0-5) °C (CONT'D)

No.	Characteristics	Symbol	Test Method MIL-STD 883	Test Fig.	Meas'd Value	Test Conditions	Limits		Unit
							Min	Max	
26	Temperature Coefficient for Input Offset Voltage	$\frac{\Delta V_{IO}}{\Delta T}$	Calculate $\Delta V_{IO}/\Delta T =$ V_{IO} (Test 1, Table 3(a) (mV) - V_{IO} (Test 1, Table 2 (mV) $\times 10$			-3.0	3.0	$\mu\text{V}/$ $^{\circ}\text{C}$	
27	Temperature Coefficient for Input (Plus) Bias Current	$\frac{\Delta I_{+IB}}{\Delta T}$	Calculate $\frac{\Delta I_{+IB}}{\Delta T} =$ I_{+IB1} (Test 5, Table 3(a) (pA) - I_{+IB1} (Test 5, Table 2 (pA) /100			-	1.5	$\text{pA}/$ $^{\circ}\text{C}$	
28	Temperature Coefficient for Input (Minus) Bias Current	$\frac{\Delta I_{-IB}}{\Delta T}$	Calculate $\frac{\Delta I_{-IB}}{\Delta T} =$ I_{-IB1} (Test 7, Table 3(a) (pA) - I_{-IB1} (Test 7, Table 2 (pA) /100			-	1.5	$\text{pA}/$ $^{\circ}\text{C}$	

NOTES: See Page 18.

**TABLE 3(b) - ELECTRICAL MEASUREMENTS AT LOW TEMPERATURE, -55(+5-0) °C**

No.	Characteristics	Symbol	Test Method MIL-STD 883	Test Fig.	Meas'd Value	Test Conditions	Limits		Unit
							Min	Max	
1	Input Offset Voltage	V_{IO1}	4001	4(a)	E_1 (V)	$+V_{CC} = 20V, -V_{CC} = -20V$ $V_{IN} = 0V$	-	0.6	mV
2	Input Offset Voltage	V_{IO2}	4001	4(a)	E_2 (V)	$+V_{CC} = 2.5V, -V_{CC} = -2.5V$ $V_{IN} = 0V$	-	0.6	mV
3	Input Offset Current	I_{IO1}	4001	4(b)	E_3 (V)	$+V_{CC} = 20V, -V_{CC} = -20V$ $C_S = 10nF, V_{IN} = 0V$	-	30	pA
4	Input Offset Current	I_{IO2}	4001	4(b)	E_4 (V)	$+V_{CC} = 2.5V, -V_{CC} = -2.5V$ $C_S = 10nF, V_{IN} = 0V$	-	30	pA
5	Input (Plus) Bias Current	I_{+IB1}	4001	4(c)	E_5 (V)	$+V_{CC} = 20V, -V_{CC} = -20V$ $C_S = 10nF, V_{IN} = 0V$	-	150	pA
6	Input (Plus) Bias Current	I_{+IB2}	4001	4(c)	E_6 (V)	$+V_{CC} = 2.5V, -V_{CC} = -2.5V$ $C_S = 10nF, V_{IN} = 0V$	-	150	pA
7	Input (Minus) Bias Current	I_{-IB1}	4001	4(d)	E_7 (V)	$+V_{CC} = 20V, -V_{CC} = -20V$ $C_S = 10nF, V_{IN} = 0V$	-	150	pA
8	Input (Minus) Bias Current	I_{-IB2}	4001	4(d)	E_8 (V)	$+V_{CC} = 2.5V, -V_{CC} = -2.5V$ $C_S = 10nF, V_{IN} = 0V$	-	150	pA
9	Power Supply Current	I_{CC}	4005	4(e)	I_{CC}	$+V_{CC} = 20V, -V_{CC} = -20V$	-	0.8	mA
10	Short Circuit Output Current (Plus)	$I_{OS(+)}$	3011	4(f)	I_{OS}	$+V_{CC} = 15V, -V_{CC} = -15V$ $V_{IN} = -15V$ Note 1	-15	-	mA
11	Short Circuit Output Current (Minus)	$I_{OS(-)}$	3011	4(f)	I_{OS}	$+V_{CC} = 15V, -V_{CC} = -15V$ $V_{IN} = +15V$ Note 1	-	15	mA
12	Open Loop Voltage Gain (Plus)	$+A_{VS}$	4004	4(g)	E_9 (V)	$+V_{CC} = 15V, -V_{CC} = -15V$ $V_{IN} = -12V, I_{OUT} = -2.0mA$	50	-	V/mV
13	Open Loop Voltage Gain (Minus)	$-A_{VS}$	4004	4(g)	E_{10} (V)	$+V_{CC} = 15V, -V_{CC} = -15V$ $V_{IN} = +12V, I_{OUT} = 2.0mA$	50	-	V/mV

NOTES: See Page 18.



TABLE 3(b) - ELECTRICAL MEASUREMENTS AT LOW TEMPERATURE, -55(+5-0) °C (CONT'D)

No.	Characteristics	Symbol	Test Method MIL-STD 883	Test Fig.	Meas'd Value	Test Conditions	Limits		Unit
							Min	Max	
26	Temperature Coefficient for Input Offset Voltage	$\frac{\Delta V_{IO}}{\Delta T}$				Calculate $\Delta V_{IO}/\Delta T =$ V_{IO} (Test 1, Table 3(b) (mV) - V_{IO} (Test 1, Table 2 (mV) $\times 12.5$	-3.0	3.0	$\mu V/^\circ C$
27	Temperature Coefficient for Input (Plus) Bias Current	$\frac{\Delta I_{+IB}}{\Delta T}$				Calculate $\frac{\Delta I_{+IB}}{\Delta T} =$ I_{+IB1} (Test 5, Table 3(b) (pA) - I_{+IB1} (Test 5, Table 2 (pA) /80	-	1.5	$\mu A/^\circ C$
28	Temperature Coefficient for Input (Minus) Bias Current	$\frac{\Delta I_{-IB}}{\Delta T}$				Calculate $\frac{\Delta I_{-IB}}{\Delta T} =$ I_{-IB1} (Test 7, Table 3(b) (pA) - I_{-IB1} (Test 7, Table 2 (pA) /80	-	1.5	$\mu A/^\circ C$

NOTES: See Page 18.



FIGURE 4(a) - INPUT OFFSET VOLTAGE

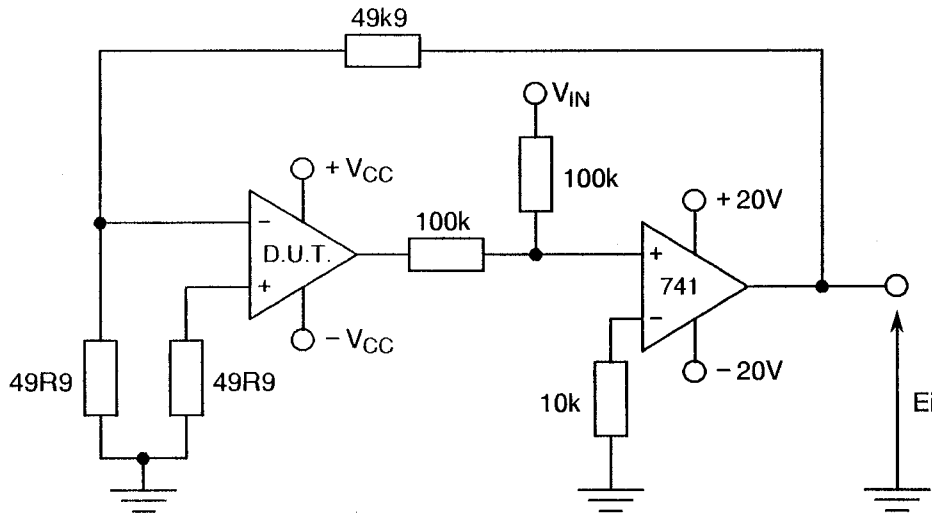

V_{IO1} (mV) = E_1 (V), V_{IO2} (mV) = E_2 (V)

NOTES

1. All resistors to be 0.1% tolerance.

FIGURE 4(b) - INPUT OFFSET CURRENT

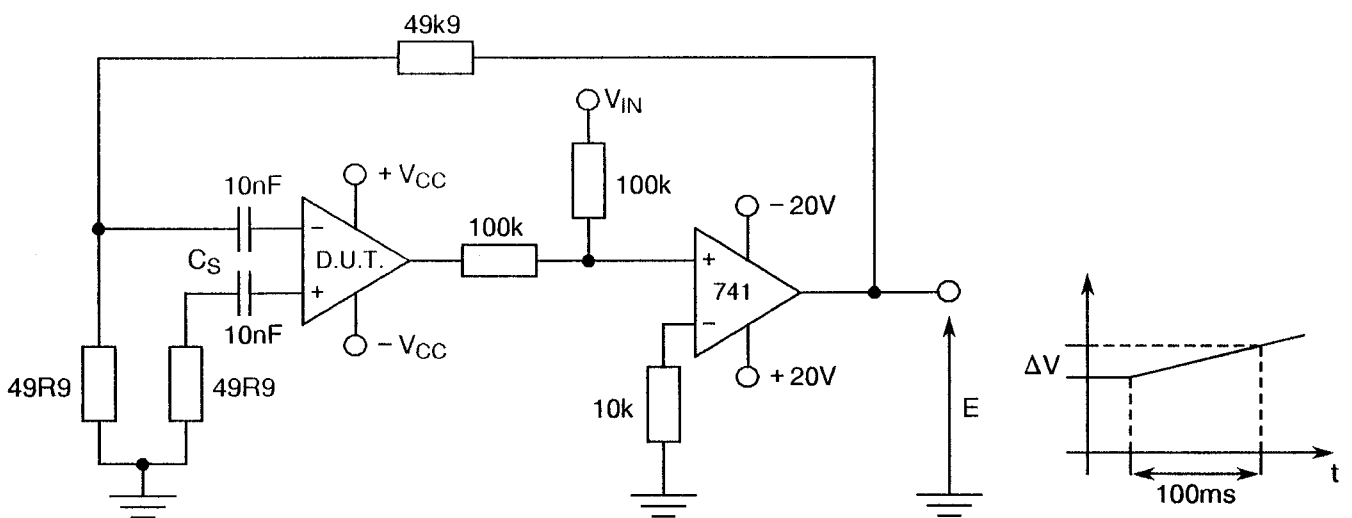

I_{O1} (pA) = $\Delta V_5 \times 100$, I_{O2} (pA) = $\Delta V_6 \times 100$

NOTES

1. All resistors to be 0.1% tolerance.
2. C_S 0.1% tolerance.



FIGURE 4(c) - INPUT (PLUS) BIAS CURRENT

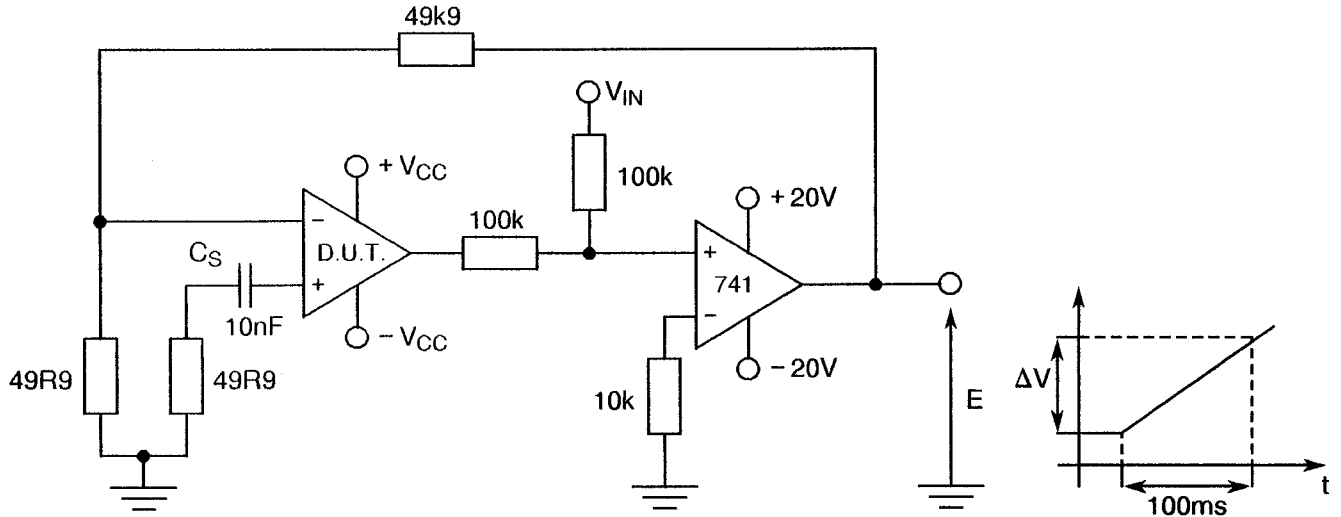

$$I_{+IB1} \text{ (pA)} = \Delta V_1 \times 100, I_{+IB2} \text{ (pA)} = \Delta V_2 \times 100$$

NOTES

1. All resistors to be 0.1% tolerance.
2. C_S 0.1% tolerance.

FIGURE 4(d) - INPUT (MINUS) BIAS CURRENT

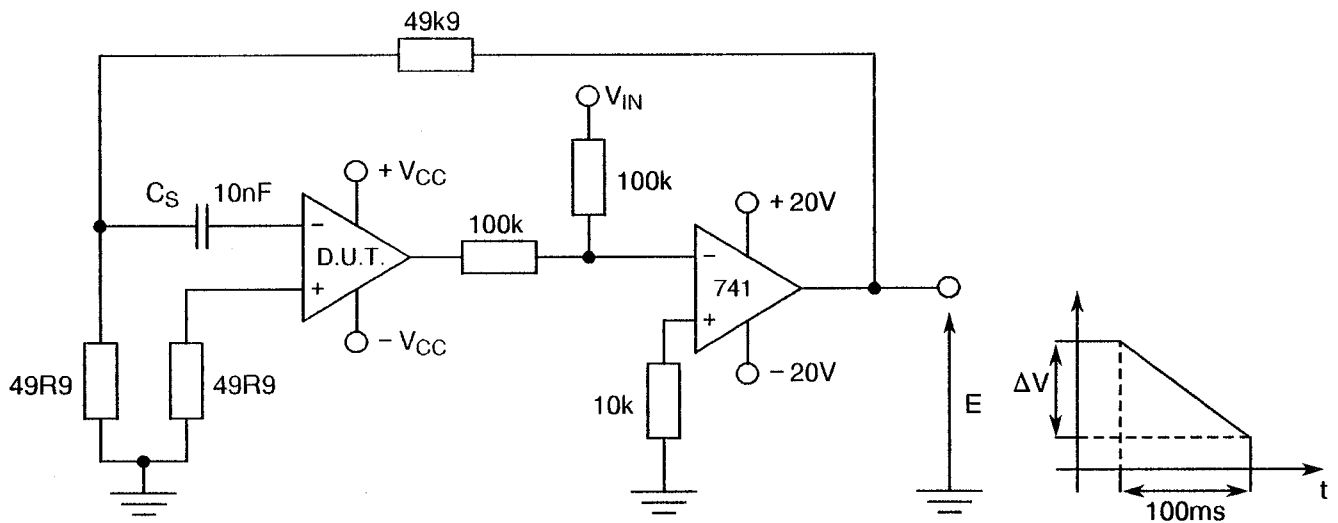

$$I_{IO1} \text{ (pA)} = \Delta V_3 \times 100, I_{IO2} \text{ (pA)} = \Delta V_4 \times 100$$

NOTES

1. All resistors to be 0.1% tolerance.
2. C_S 0.1% tolerance.



FIGURE 4(e) - SUPPLY CURRENT

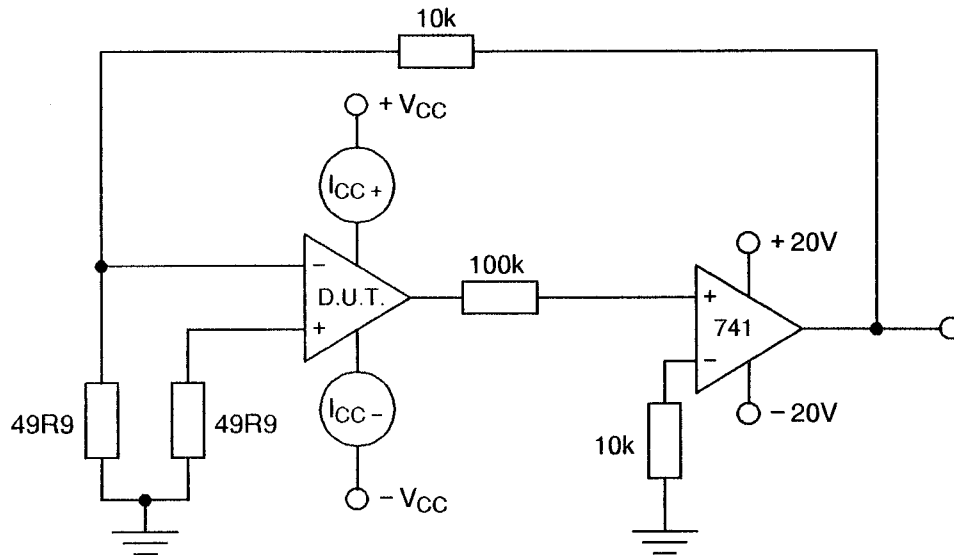

NOTES

1. All resistors to be 0.1% tolerance.

FIGURE 4(f) - SHORT CIRCUIT OUTPUT CURRENT

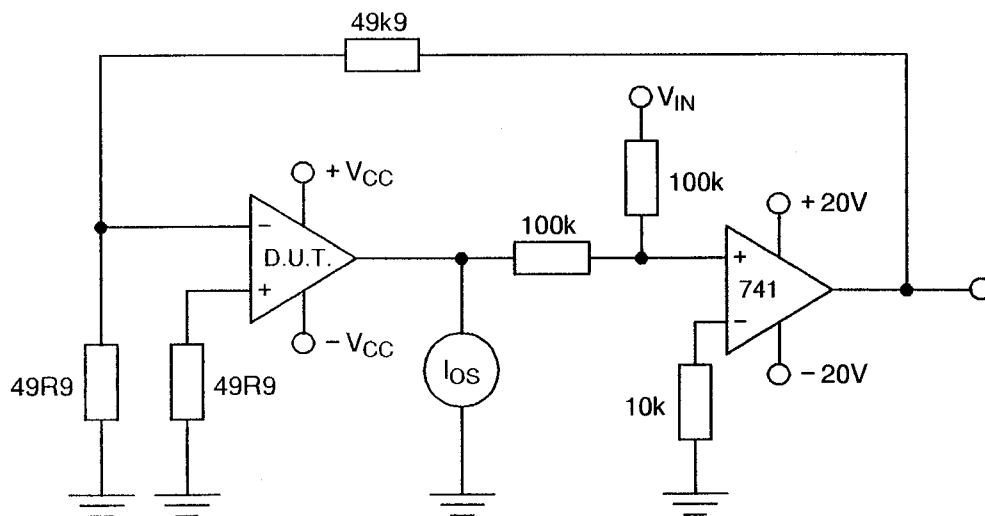

NOTES

1. All resistors to be 0.1% tolerance.



FIGURE 4(g) - OPEN LOOP VOLTAGE GAIN

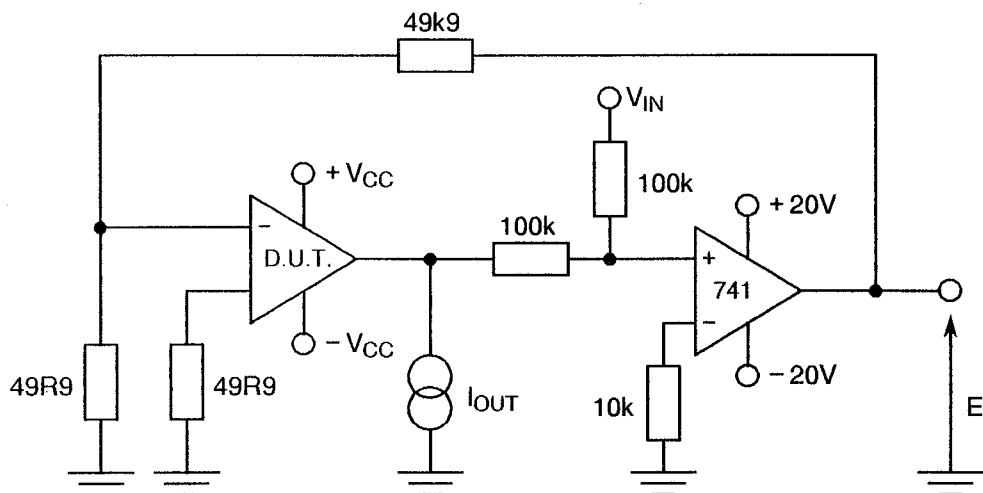

1. $V_{IN} = +12V$

$$2. \quad +A_{VS} = \frac{12}{E_1 - E_9} \quad +A_{VS} = \frac{12}{E_2 - E_{11}}$$

$$3. \quad -A_{VS} = \frac{12}{E_{10} - E_1} \quad -A_{VS} = \frac{12}{E_{12} - E_2}$$

NOTES

1. E_9, E_{10}, E_{11} and E_{12} are in Volts.
2. All resistors to be 0.1% tolerance.

FIGURE 4(h) - POWER SUPPLY REJECTION RATIO

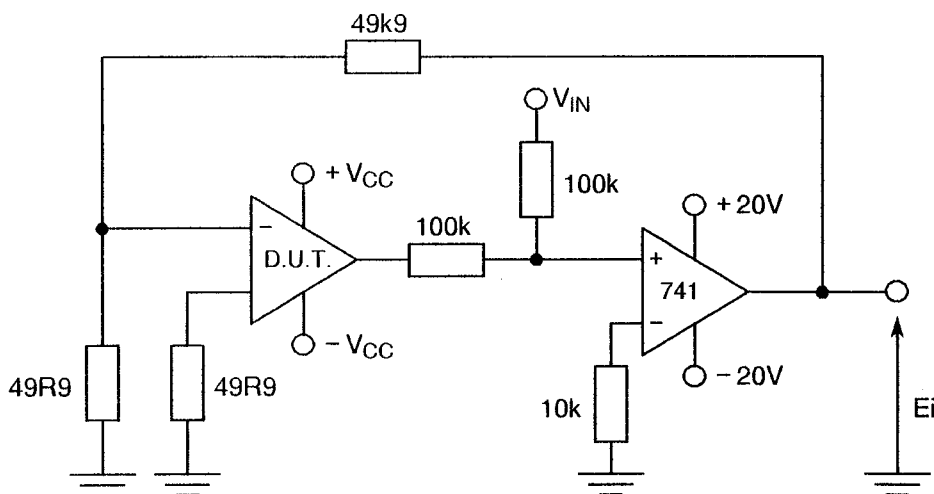

$$+PSRR(\mu V/V) = ((E_1 (V) - E_{13} (V)) 10^3) / 17.5,$$

$$-PSRR(\mu V/V) = ((E_1 (V) - E_{14} (V)) 10^3) / 17.5$$

NOTES

1. All resistors to be 0.1% tolerance.
2. E_1 is measured to 4 digits accuracy.



FIGURE 4(i) - COMMON MODE REJECTION RATIO

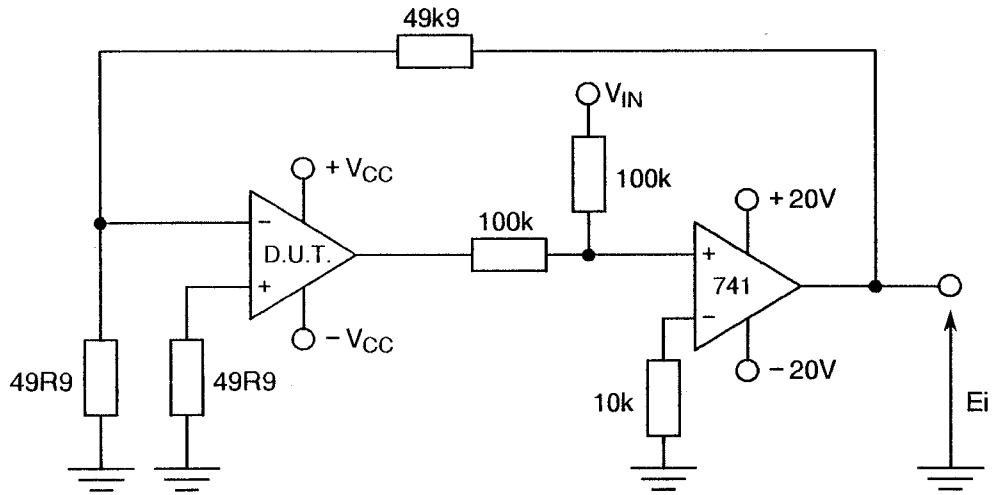

$$\text{CMRR (dB)} = 20 \text{ LOG } \frac{27.10^3}{E_{15} \text{ (V)} - E_{16} \text{ (V)}}$$

NOTES

1. Resistors of 49R9Ω at inputs shall be of 0.01% tolerance matched to 0.01%. Remaining resistors shall be of 0.1% tolerance.



FIGURE 4(i) - DYNAMIC TEST MEASUREMENT CIRCUIT

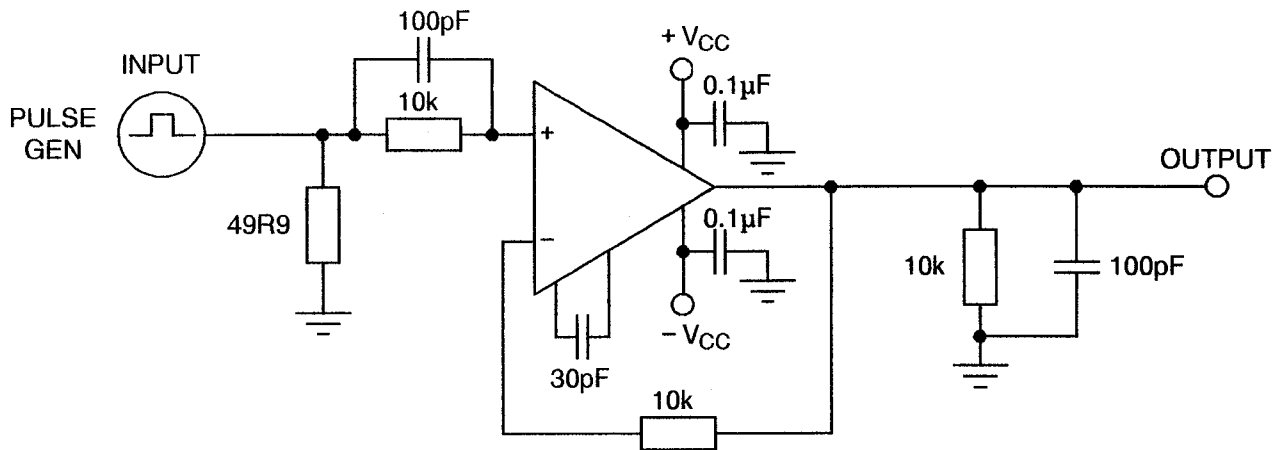

NOTES

1. Pulse Generator:

- Rise time $\leq 10\text{ns}$
- Repetition rate 1.0kHz (max.)
- Pulse voltage: -5.0V to $+5.0\text{V}$ for slew rate measurement
- Pulse voltage: 50mV for rise time and overshoot measurement

$$SR = \left| \frac{\Delta V_0}{\Delta T} \right| \text{ (V/}\mu\text{s)}$$

$$RT = t \text{ (}\mu\text{s)}$$

$$OS = \frac{\Delta V}{50} \times 100(\%)$$

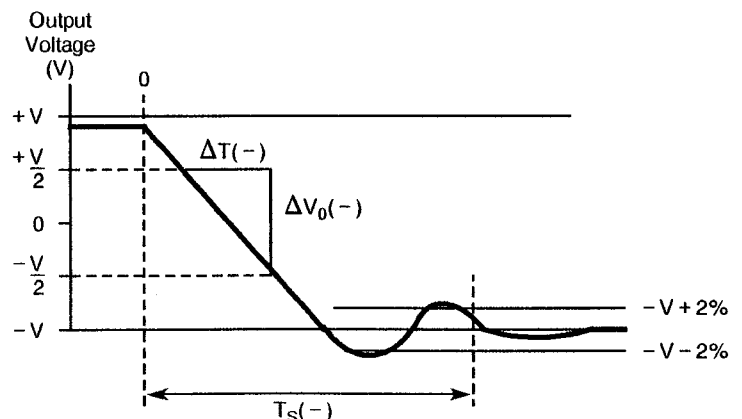
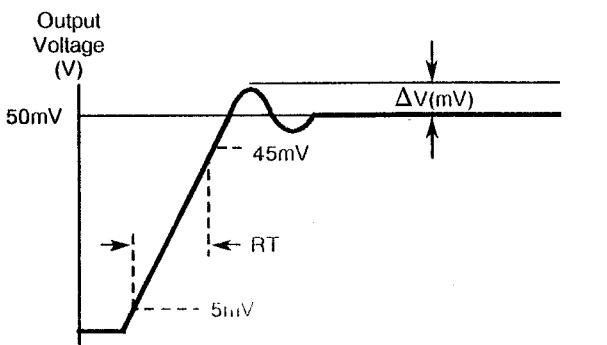
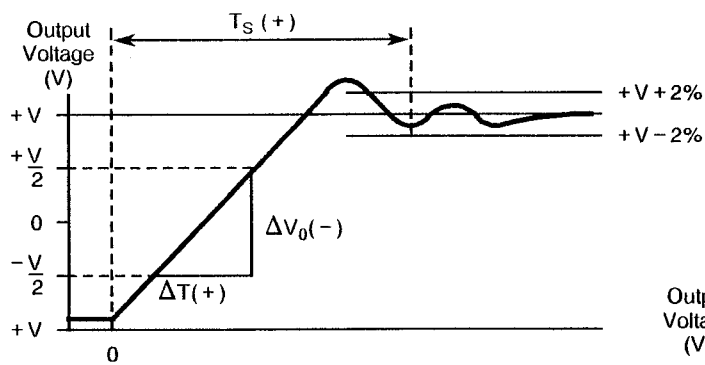



TABLE 4 - PARAMETER DRIFT VALUES

No.	CHARACTERISTICS	SYMBOL	SPEC. AND/OR TEST METHOD	TEST CONDITIONS	CHANGE LIMITS (Δ)	UNIT
1	Input Offset Voltage Change	V_{IO1}	As per Table 2	As per Table 2	± 0.15	mV
3	Input Offset Current Change	I_{IO1}	As per Table 2	As per Table 2	± 10	pA
5	Input Bias Current Change	I_{+IB1}	As per Table 2	As per Table 2	± 20	pA

TABLE 5 - CONDITIONS FOR BURN-IN

No.	CHARACTERISTICS	SYMBOL	CONDITION	UNIT
1	Ambient Temperature	T_{amb}	$+ 125 \pm 5$	$^{\circ}\text{C}$
2	Supply Voltage	V_{CC}	± 20	V

FIGURE 5 - ELECTRICAL CIRCUIT FOR BURN-IN

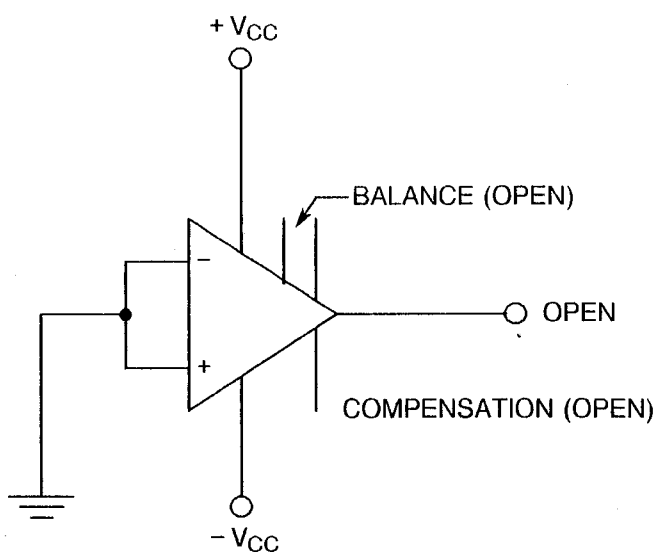

	<p style="text-align: center;">ESA/SCC Detail Specification No. 9101/022</p>		<p>PAGE 30 ISSUE 1</p>
---	--	--	----------------------------

4.8 ENVIRONMENTAL AND ENDURANCE TESTS

4.8.1 Electrical Measurements on Completion of Environmental Tests

The parameters to be measured on completion of environmental tests are scheduled in Table 6. Unless otherwise stated, the measurements shall be performed at $T_{amb} = +22 \pm 3$ °C.

4.8.2 Electrical Measurements at Intermediate Points during Endurance Tests

The parameters to be measured at intermediate points during endurance tests are as scheduled in Table 6 of this specification. Unless otherwise stated, the measurements shall be performed at $T_{amb} = +22 \pm 3$ °C.

4.8.3 Electrical Measurements on Completion of Endurance Tests

The parameters to be measured on completion of endurance testing are as scheduled in Table 6 of this specification. Unless otherwise stated, the measurements shall be performed at $T_{amb} = +22 \pm 3$ °C.

4.8.4 Conditions for Operating Life Tests

The requirements for operating life testing are specified in Section 9 of ESA/SCC Generic Specification No. 9000. The conditions for operating life testing shall be as specified in Table 5 of this specification.

4.8.5 Electrical Circuits for Operating Life Tests

Circuits for use in performing the operating life tests are shown in Figure 5 of this specification.

4.8.6 Conditions for High Temperature Storage Test

The requirements for the high temperature storage test are specified in ESA/SCC Generic Specification No. 9000. The conditions for high temperature storage shall be $T_{amb} = +150(+0 - 5)$ °C.

TABLE 6 - ELECTRICAL MEASUREMENTS ON COMPLETION OF ENVIRONMENTAL TESTS AND AT INTERMEDIATE POINTS AND ON COMPLETION OF ENDURANCE TESTING

No.	CHARACTERISTICS	SYMBOL	SPEC. AND/OR TEST METHOD	TEST CONDITIONS	LIMITS		UNIT
					MIN	MAX	
1	Input Offset Voltage	V_{IO1}	As per Table 2	As per Table 2	-	0.3	mV
3	Input Offset Current	I_{IO1}	As per Table 2	As per Table 2	-	10	pA
5	Input Bias Current	I_{+IB1}	As per Table 2	As per Table 2	-	50	pA
9	Power Supply Current	I_{CC}	As per Table 2	As per Table 2	-	0.6	mA
12	Open Loop Voltage Gain	$+A_{VS}$	As per Table 2	As per Table 2	100	-	V/mV