



europaean space agency
agence spatiale européenne

Pages 1 to 26

INTEGRATED CIRCUITS, SILICON MONOLITHIC

BIPOLAR VOLTAGE REGULATOR

BASED ON TYPE LM 105

ESA/SCC Detail Specification No. 9102/002

SCC

**space components
coordination group**

| Issue/Rev. | Date | Approved by | |
|--------------|----------------|------------------|---------------------------------------|
| | | SCCG Chairman | ESA Director General or his Deputy |
| Issue 3 | March 1982 | - | - |
| Revision 'A' | September 1984 | - | - |
| Revision 'B' | December 1991 | <i>P. Pommeu</i> | <i>J. Lab</i> |
| | | | |



DOCUMENTATION CHANGE NOTICE

| Rev. Letter | Rev. Date | Reference | CHANGE Item | Approved DCR No. |
|-------------|-----------|---|---|--------------------------------|
| | | This issue supersedes Issue 2 and incorporates all modifications agreed on the basis of Policy DCR 21019 (Appendices to Detail Specifications), DCR 23058 (new Table 2, 3(a) and 3(b) format) and the following DCR's:- | | |
| | | P7. Table 1(b) | : Item 2 maximum rating changed | 22127 |
| 'A' | Sep. '84 | P1. Cover Page P2. DCN P6. Table 1(a) Table 1(b) | : Lead material and finish redefined : Notes 1, 2 and 3 derating factors amended. Format amended | None None 21025 22292 |
| | | P7. Figure 1 | : Amended | 22292 |
| | | P13. Para. 2 | : MIL-STD-1276 deleted | 21025 |
| | | Para. 4.2.2 | : PIND testing added | 22240 |
| | | P15. Para. 4.4.2 | : Rewritten | 21025 |
| 'B' | Dec. '91 | P1. Cover page P2. DCN P3. T of C | : Para. 4.3.3 deleted | None None None |
| | | P13. Para. 4.2.2 | : Deviation deleted, "None." added | 21048 |
| | | P14. Para. 4.2.4 | : Deviation deleted, "None." added | 22919 |
| | | Para. 4.2.5 | : Deviation deleted, "None." added | 22919 |
| | | Para. 4.3.3 | : Paragraph deleted | 22921 |
| | | This specification has been transferred from hardcopy to electronic format. The content is unchanged but minor differences in presentation exist. | | |



TABLE OF CONTENTS

| | <u>Page</u> |
|---|-------------|
| 1. <u>GENERAL</u> | 5 |
| 1.1 Scope | 5 |
| 1.2 Component Type Variants | 5 |
| 1.3 Maximum Ratings | 5 |
| 1.4 Parameter Derating Information | 5 |
| 1.5 Physical Dimensions | 5 |
| 1.6 Pin Assignment | 5 |
| 1.7 Truth Table | 5 |
| 1.8 Circuit Schematic | 5 |
| 1.9 Functional Diagram | 5 |
| 2. <u>APPLICABLE DOCUMENTS</u> | 13 |
| 3. <u>TERMS, DEFINITIONS, ABBREVIATIONS, SYMBOLS AND UNITS</u> | 13 |
| 4. <u>REQUIREMENTS</u> | 13 |
| 4.1 General | 13 |
| 4.2 Deviations from Generic Specification | 13 |
| 4.2.1 Deviations from Special In-process Controls | 13 |
| 4.2.2 Deviations from Final Production Tests (Chart II) | 13 |
| 4.2.3 Deviations from Burn-in Tests (Chart III) | 14 |
| 4.2.4 Deviations from Qualification, Environmental and Endurance Tests (Chart IV) | 14 |
| 4.2.5 Deviations from Lot Acceptance Tests (Chart V) | 14 |
| 4.3 Mechanical Requirements | 14 |
| 4.3.1 Dimension Check | 14 |
| 4.3.2 Weight | 14 |
| 4.4 Materials and Finishes | 14 |
| 4.4.1 Case | 14 |
| 4.4.2 Lead Material and Finish | 15 |
| 4.5 Marking | 15 |
| 4.5.1 General | 15 |
| 4.5.2 Lead Identification | 15 |
| 4.5.3 The SCC Component Number | 15 |
| 4.5.4 Traceability Information | 15 |
| 4.5.5 Marking of Small Components | 15 |
| 4.6 Electrical Characteristics | 16 |
| 4.6.1 Electrical Measurements at Room Temperature | 16 |
| 4.6.2 Electrical Measurements at High and Low Temperatures | 16 |
| 4.6.3 Circuits for Electrical Measurements | 16 |



| | <u>Page</u> | |
|-------|---|----|
| 4.7 | Burn-in Tests | 16 |
| 4.7.1 | Parameter Drift Values | 16 |
| 4.7.2 | Conditions for Burn-in | 16 |
| 4.7.3 | Electrical Circuits for Burn-in | 16 |
| 4.8 | Environmental and Endurance Tests | 25 |
| 4.8.1 | Electrical Measurements on Completion of Environmental Tests | 25 |
| 4.8.2 | Electrical Measurements at Intermediate Points During Endurance Tests | 25 |
| 4.8.3 | Electrical Measurements on Completion of Endurance Tests | 25 |
| 4.8.4 | Conditions for Operating Life Tests | 25 |
| 4.8.5 | Electrical Circuits for Operating Life Tests | 25 |
| 4.8.6 | Conditions for High Temperature Storage Test | 25 |

TABLES

| | | |
|------|--|----|
| 1(a) | Type Variants | 6 |
| 1(b) | Maximum Ratings | 6 |
| 2 | Electrical Measurements at Room Temperature | 17 |
| 3(a) | Electrical Measurements at High Temperature | 19 |
| 3(b) | Electrical Measurements at Low Temperature | 21 |
| 4 | Parameter Drift Values | 24 |
| 5 | Conditions for Burn-in and Operating Life Tests | 24 |
| 6 | Electrical Measurements on Completion of Environmental Tests and at Intermediate Points and on Completion of Endurance Testing | 26 |

FIGURES

| | | |
|------|--|----|
| 1 | Device Dissipation Derating with Temperature | 7 |
| 2(a) | Physical Dimensions - Flat Package | 8 |
| 2(b) | Physical Dimensions - TO-99 Package | 9 |
| 2(c) | Physical Dimensions - Dual-in-Line Package | 10 |
| 3(a) | Pin Configuration | 11 |
| 3(c) | Circuit Schematic | 11 |
| 3(d) | Functional Diagram | 12 |
| 4 | Circuits for Electrical Measurements | 23 |
| 5 | Circuit for Burn-in and Operating Life Test | 24 |

APPENDICES (Applicable to specific Manufacturers only)

None.

**1. GENERAL****1.1 SCOPE**

This specification details the ratings, physical and electrical characteristics, test and inspection data for a silicon monolithic, bipolar voltage regulator, based on Type LM105. It shall be read in conjunction with ESA/SCC Generic Specification No.9000, the requirements of which are supplemented herein.

1.2 COMPONENT TYPE VARIANTS

Variants of the basic type integrated circuits specified herein, which are also covered by this specification, are given in Table 1(a).

1.3 MAXIMUM RATINGS

The maximum ratings, which shall not be exceeded at any time during use or storage, applicable to the integrated circuits specified herein, are as scheduled in Table 1(b).

1.4 PARAMETER DERATING INFORMATION

As per Figure 1.

1.5 PHYSICAL DIMENSIONS

As per Figure 2.

1.6 PIN ASSIGNMENT

As per Figure 3(a).

1.7 TRUTH TABLE (FIGURE 3(b))

Not applicable.

1.8 CIRCUIT SCHEMATIC

As per Figure 3(c).

1.9 FUNCTIONAL DIAGRAM

As per Figure 3(d).

**TABLE 1(a) - TYPE VARIANTS**

| VARIANT | CASE | FIGURE | LEAD MATERIAL AND FINISH |
|---------|------|--------|--------------------------|
| -01 | FLAT | 2(a) | D2 |
| -02 | FLAT | 2(a) | D3 or D4 |
| -03 | TO99 | 2(b) | D2 |
| -04 | TO99 | 2(b) | D3 or D4 |
| -05 | DIL | 2(c) | D2 |
| -06 | DIL | 2(c) | D3 or D4 |

TABLE 1(b) - MAXIMUM RATINGS

| No. | CHARACTERISTICS | SYMBOL | MAXIMUM RATINGS | UNITS | REMARKS |
|-----|--|-------------|-----------------|-------|---|
| 1 | Input Voltage | V_I | 50 | V | |
| 2 | Input-Output Voltage Differential | $V_I - V_O$ | 40 | V | |
| 3 | Device Power Dissipation - Variants 01-02 - Variants 03-04 - Variants 05-06 | P_D | 500 | mW | Notes 1 and 4 Notes 2 and 4 Notes 3 and 4 |
| 4 | Output Current | I_O | 25 | mA | |
| 5 | Operating Temperature Range | T_{amb} | - 55 to + 125 | °C | |
| 6 | Storage Temperature Range | T_{stg} | - 55 to + 150 | °C | |
| 7 | Soldering Temperature | T_{sol} | + 300 | °C | Note 5 |
| 8 | Junction Temperature | T_J | + 150 | °C | |

NOTES

1. Derate above $T_{amb} = +55^{\circ}\text{C}$ at 5.26mW/°C. See Figure 1.
2. Derate above $T_{amb} = +75^{\circ}\text{C}$ at 6.67mW/°C. See Figure 1.
3. Derate above $T_{amb} = +90^{\circ}\text{C}$ at 8.33mW/°C. See Figure 1.
4. Peak dissipation to 1.0W is allowed provided the dissipation rating is not exceeded with the power average over a 5 second interval.
5. Duration: 2 to 5 seconds.



FIGURE 1 - DEVICE DISSIPATION DERATING WITH TEMPERATURE

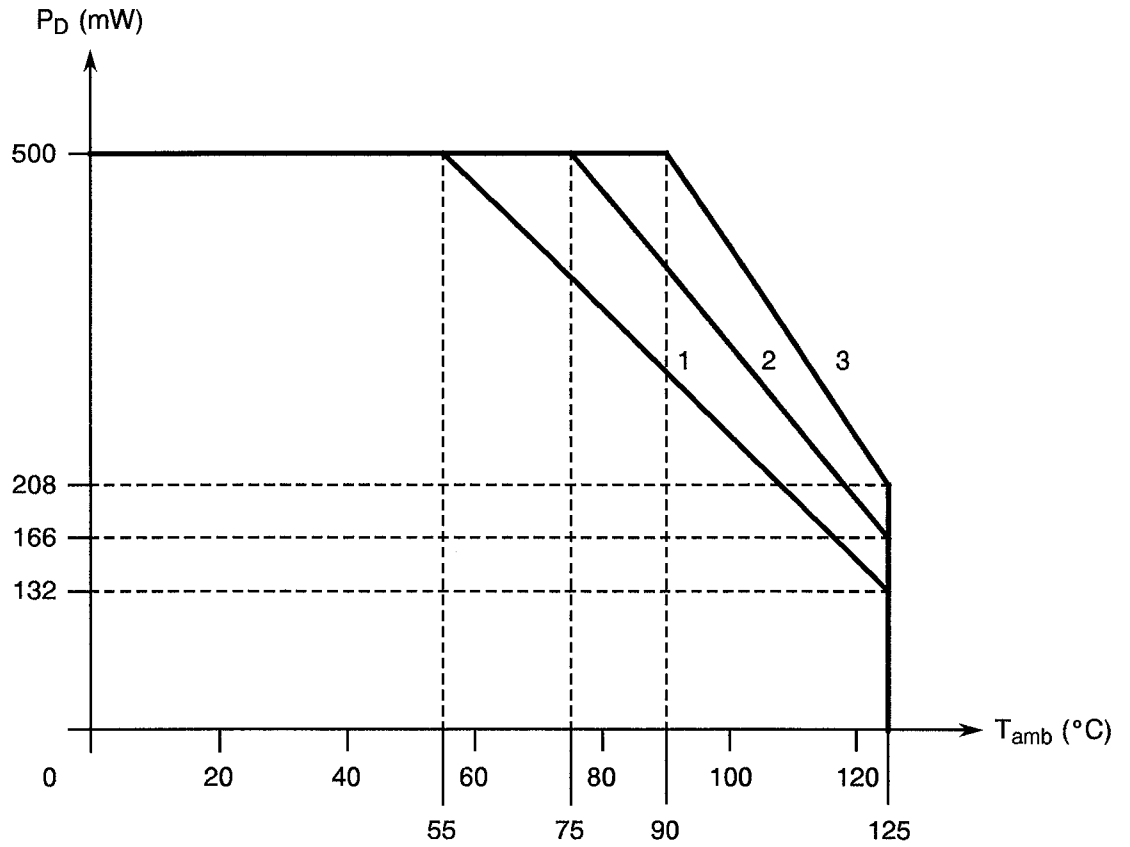

NOTES

1. Derating for type variants 01 and 02.
2. Derating for type variants 03 and 04.
3. Derating for type variants 05 and 06.



FIGURE 2 - PHYSICAL DIMENSIONS

FIGURE 2(a) - FLAT PACKAGE

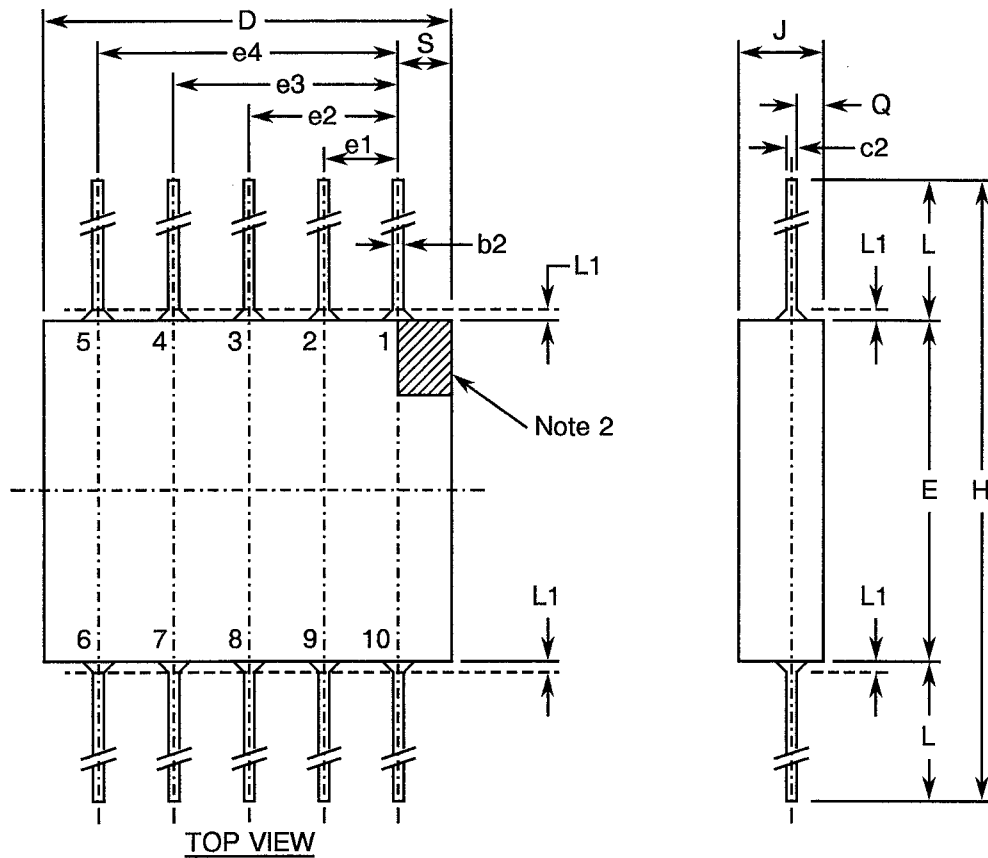

The metric dimensions are calculated from the original dimensions in inches.

| SYMBOL | MILLIMETRES | | INCHES | | NOTES |
|--------|-------------|-------|--------|-------|-------|
| | MIN. | MAX. | MIN. | MAX. | |
| b2 | 0.254 | 0.482 | 0.010 | 0.019 | |
| c2 | 0.077 | 0.152 | 0.003 | 0.006 | |
| D | 6.10 | 6.98 | 0.240 | 0.275 | |
| E | 6.10 | 6.60 | 0.240 | 0.260 | |
| e1 | 1.15 | 1.39 | 0.045 | 0.055 | 1 |
| e2 | 2.42 | 2.66 | 0.095 | 0.105 | 1 |
| e3 | 3.69 | 3.93 | 0.145 | 0.155 | 1 |
| e4 | 4.96 | 5.20 | 0.195 | 0.205 | 1 |
| H | 13.72 | 19.81 | 0.540 | 0.780 | |
| J | 0.77 | 1.77 | 0.030 | 0.070 | |
| L | 3.81 | 6.60 | 0.150 | 0.260 | |
| L1 | - | 0.38 | - | 0.015 | |
| Q | 0.13 | 0.88 | 0.005 | 0.035 | |
| S | 0.52 | 0.88 | 0.020 | 0.035 | |

NOTES

1. The distance between terminals shall be measured at maximum 0.76mm (0.030 inch) from where they emerge from the case.
2. The top face and Pin No. 1 are marked.



FIGURE 2 - PHYSICAL DIMENSIONS (CONTINUED)

FIGURE 2(b) - TO99 PACKAGE

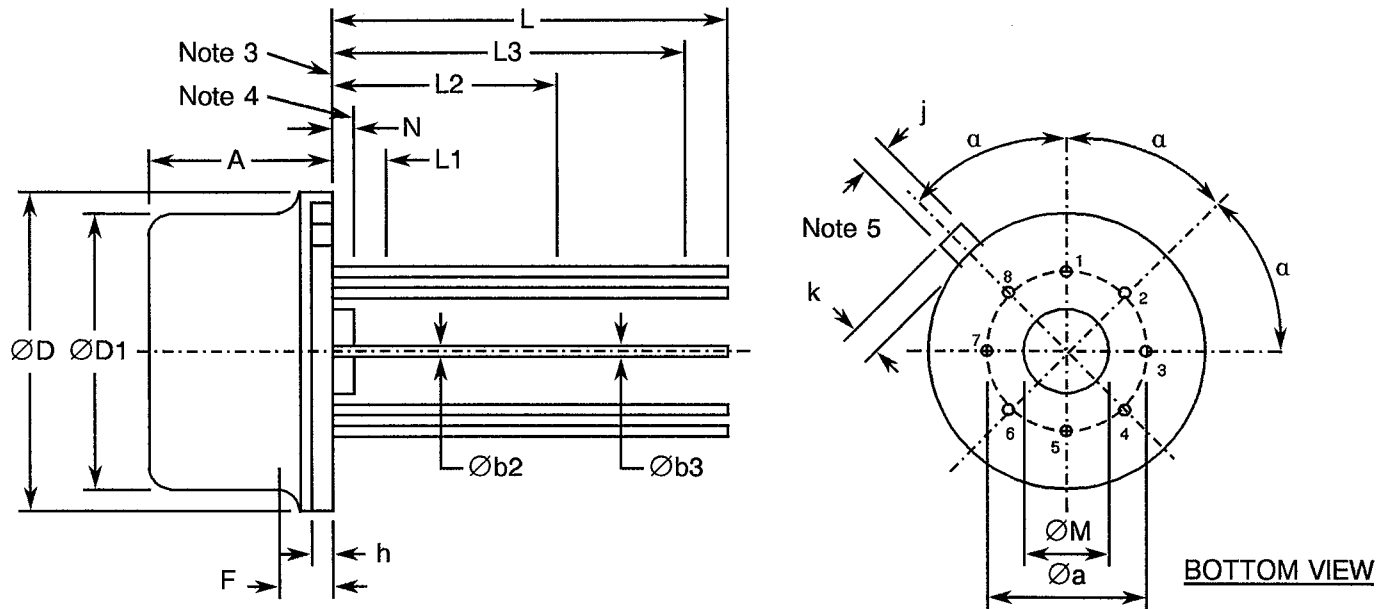

| SYMBOL | MILLIMETRES | | | INCHES | | | DEGR. NOM. | NOTES |
|--------|-------------|----------|-------|--------|-----------|-------|------------|-------|
| | MIN. | NOM. | MAX. | MIN. | NOM. | MAX. | | |
| Øa | - | 5.08 (*) | - | - | 0.200 (*) | - | | 1 |
| A | 4.20 | - | 4.69 | 0.165 | - | 0.185 | | |
| Øb2 | 0.407 | - | 0.508 | 0.016 | - | 0.020 | | |
| Øb3 | - | - | 0.53 | - | - | 0.021 | | |
| ØD | 8.51 | - | 9.39 | 0.335 | - | 0.370 | | |
| ØD1 | 7.75 | - | 8.50 | 0.305 | - | 0.335 | | |
| F | - | - | 1.27 | - | - | 0.050 | | |
| h | 0.15 | - | 1.01 | 0.006 | - | 0.040 | | |
| j | 0.712 | - | 0.863 | 0.028 | - | 0.034 | | |
| k | 0.74 | - | 1.14 | 0.029 | - | 0.045 | | 2 |
| L | 12.50 | - | 14.50 | 0.492 | - | 0.071 | | |
| L1 | - | - | 1.27 | - | - | 0.050 | | |
| L2 | 6.35 | - | - | 0.250 | - | - | | |
| L3 | 12.70 | - | - | 0.500 | - | - | | |
| ØM | 3.56 | - | 4.06 | 0.140 | - | 0.160 | | |
| N | 0.26 | - | 1.01 | 0.010 | - | 0.040 | | |
| α | | | | | | | 45° (*) | 1 |

NOTES

- The section of each terminal, from a distance of 1.37mm (0.054 inch) to the reference plane, shall be located in a ring whose diameter is 0.99mm (0.039 inch), centred on the accurate geometrical point defining the terminal axis.
- Measured from the D diameter.
- Reference plane.
- Base plane.
- Reference index of Pin 8.

* = accurate geometrical location.

The metric dimensions are calculated from the original dimensions in inches.

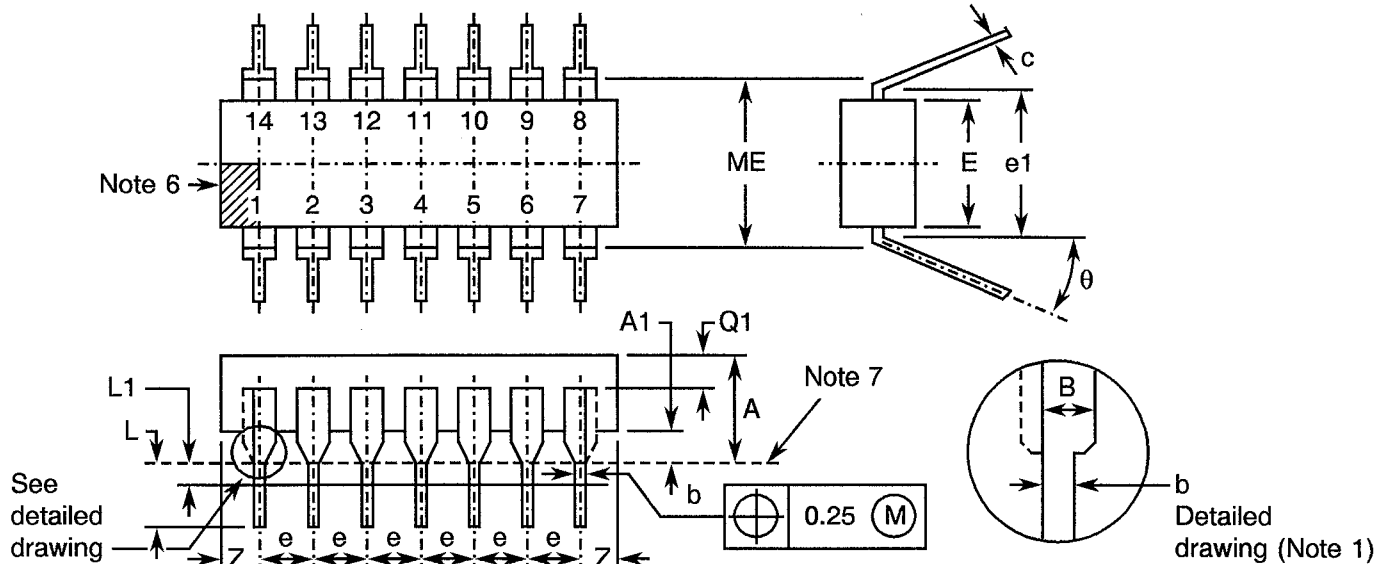
**FIGURE 2 - PHYSICAL DIMENSIONS (CONTINUED)****FIGURE 2(c) - DUAL-IN-LINE PACKAGE**

| SYMBOL | MILLIMETRES | | | INCHES | | | DEGREES | | NOTES |
|----------|-------------|--------|-------|--------|---------|-------|---------|------|-------|
| | MIN. | NOM. | MAX. | MIN. | NOM. | MAX. | MIN. | MAX. | |
| A | - | - | 5.08 | - | - | 0.200 | | | |
| A1 | 0.51 | - | - | 0.020 | - | - | | | |
| B | - | - | 1.77 | - | - | 0.070 | | | 1 |
| b | 0.381 | - | 0.508 | 0.015 | - | 0.020 | | | 1 |
| c | 0.204 | - | 0.304 | 0.008 | - | 0.012 | | | |
| E | - | 6.3 | - | - | 0.25 | - | | | |
| e | - | 2.54 * | - | - | 0.100 * | - | | | 2 |
| e1 | - | 7.62 * | - | - | 0.300 * | - | | | 3 |
| L | 2.5 | - | 3.9 | 0.098 | - | 0.154 | | | (a) |
| L1 | - | - | 0.76 | - | - | 0.030 | | | |
| ME | 7.62 | - | 8.25 | 0.300 | - | 0.325 | | | 3 |
| Q1 | - | - | 2.03 | - | - | 0.080 | | | |
| Z | | | | | | | | | 4 |
| θ | | | | | | | 0 | 15 | |
| n = | 7 × 2 | | | | | | | | 5 |

NOTES

- The lead profile is not required for transition from B to b. The outline of the extreme outputs in the case of F.105A may differ from that of the others, as shown in the Figure.
 - The space between leads is measured on the area L1.
 - Measured when the value of the angle θ is zero.
 - Case F.105: Z between $e/2$ and e ($1.27\text{mm} < Z < 2.54\text{mm}$).
Case F.105A: Z less than $e/2$ ($Z < 1.27\text{mm}$).
 - n = quantity of leads.
 - Area for visible reference mark on top face.
 - Base plane.
* = accurate geometrical location.
- (a) Recommended dimensions for the future: minimum 3.0mm (0.122 inch).
maximum 3.9mm (0.154 inch).
- The metric dimensions are calculated from the original dimensions in inches.



FIGURE 3(a) - PIN CONFIGURATION

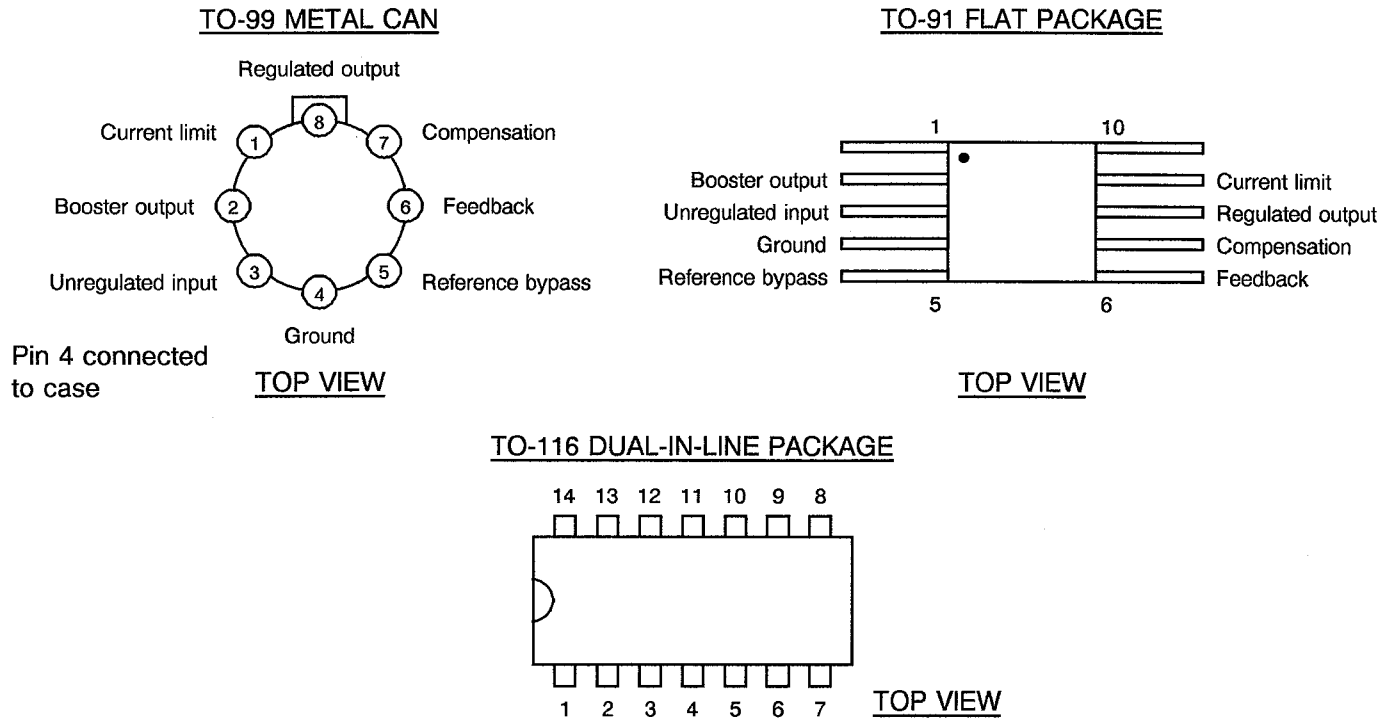

FIGURE 3(b) - TRUTH TABLE

Not applicable.

FIGURE 3(c) - CIRCUIT SCHEMATIC (FOR INFORMATION ONLY)

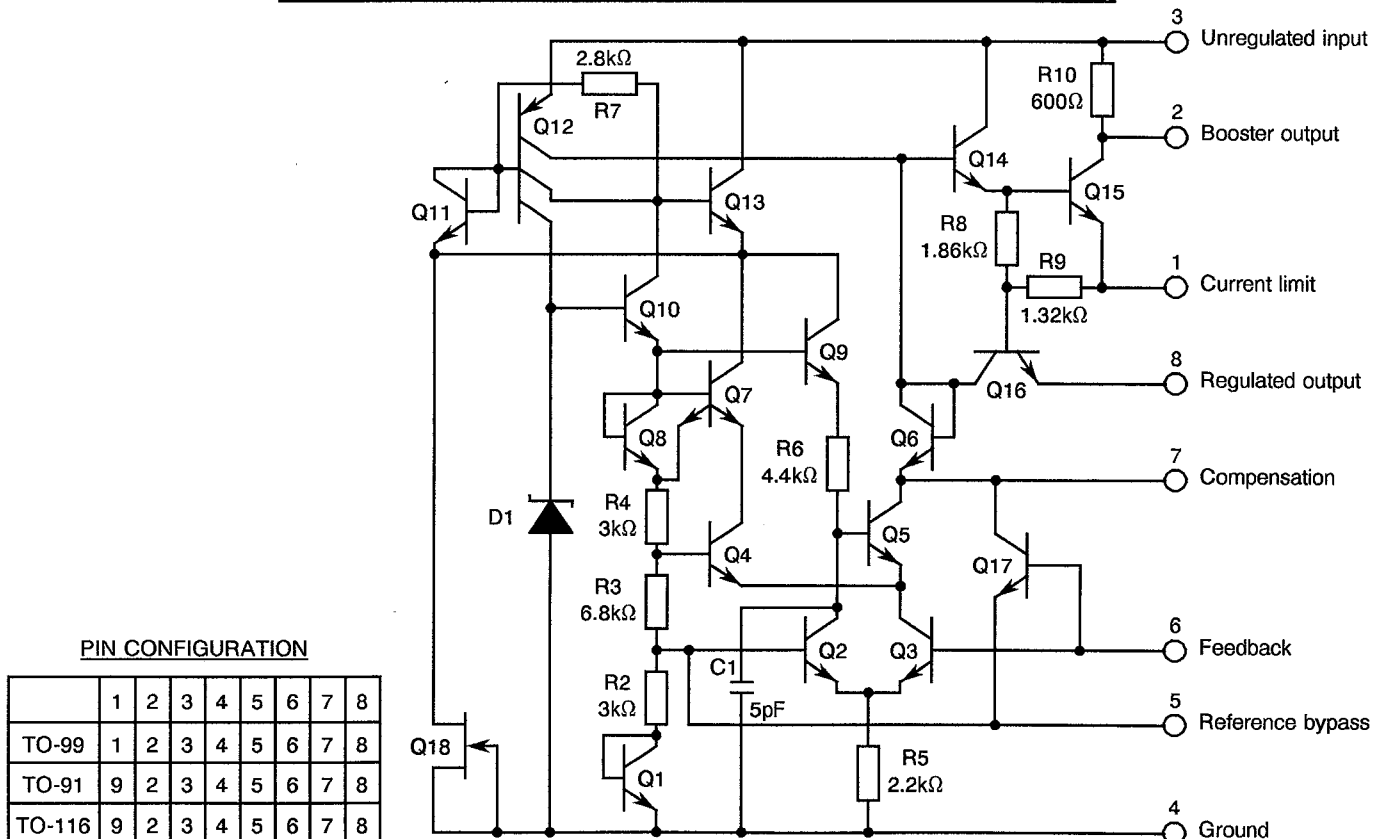
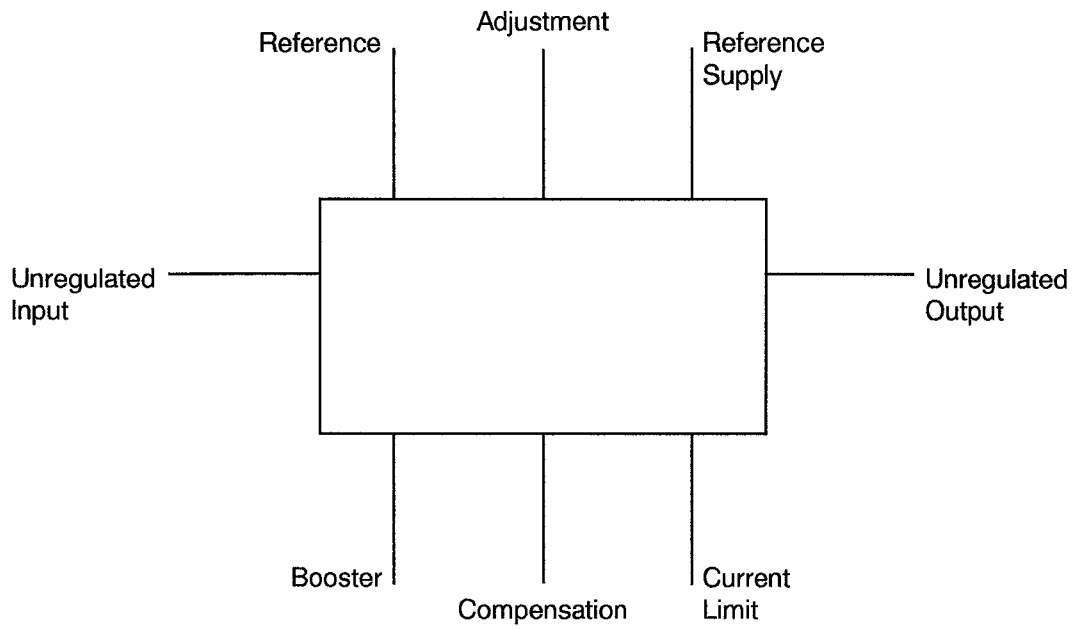





FIGURE 3(d) - FUNCTIONAL DIAGRAM



| | | | |
|---|--|---|---|
|   | <p style="text-align: center;">ESA/SCC Detail Specification No. 9102/002</p> | <p style="text-align: center;">Rev. 'B'</p> | <p style="text-align: right;">PAGE 13 ISSUE 3</p> |
|---|--|---|---|

2. APPLICABLE DOCUMENTS

The following documents form part of this specification and shall be read in conjunction with it:-

- (a) ESA/SCC Generic Specification No. 9000 for Integrated Circuits.
- (b) MIL-STD-883, Test Methods and Procedures for Micro-electronics.

3. TERMS, DEFINITIONS, ABBREVIATIONS, SYMBOLS AND UNITS

For the purpose of this specification, the terms, definitions, abbreviations, symbols and units specified in ESA/SCC Basic Specification No. 21300 shall apply. In addition, the following abbreviations are used:-

- K_{VI} = Input Regulation Coefficient.
- K_{VO} = Output Regulation Coefficient.
- K_{VT} = Regulation Temperature Coefficient.
- I_Q = Standby Current.
- V_{SC} = Current Limit Sense Voltage.

4. REQUIREMENTS

4.1 GENERAL

The complete requirements for procurement of the integrated circuits specified herein are stated in this specification and ESA/SCC Generic Specification No. 9000 for Integrated Circuits. Deviations from the Generic Specification applicable to this specification only, are listed in Para. 4.2.

Deviations from the applicable Generic Specification and this Detail Specification, formally agreed with specific Manufacturers on the basis that the alternative requirements are equivalent to the ESA/SCC requirements and do not affect the components' reliability, are listed in the appendices attached to this specification.

4.2 DEVIATIONS FROM GENERIC SPECIFICATION

4.2.1 Deviations from Special In-process Controls

None.

4.2.2 Deviations from Final Production Tests (Chart II)

None.



4.2.3 Deviations from Burn-in Tests (Chart III)

Subpara. 7.1.1(a), "High Temperature Reverse Bias" test and subsequent electrical measurements related to this test shall be omitted.

4.2.4 Deviations from Qualification, Environmental and Endurance Tests (Chart IV)

None.

4.2.5 Deviations from Lot Acceptance Tests (Chart V)

None.

4.3 MECHANICAL REQUIREMENTS

4.3.1 Dimension Check

The dimensions of the integrated circuits specified herein shall be checked. They shall conform to those shown in Figure 2.

4.3.2 Weight

The maximum weight of the integrated circuits specified herein shall be for:-

Variants 01, 02: 0.35 grammes.

Variants 03, 04: 1.50 grammes.

Variants 05, 06: 2.00 grammes.

4.4 MATERIALS

The materials shall be as specified herein. Where a definite material is not specified, a material which will enable the integrated circuits specified herein to meet the performance requirements of this specification shall be used. Acceptance or approval of any constituent material does not guarantee acceptance of the finished product.

4.4.1 Case

The case shall be hermetically sealed and have a metal body with hard glass seals or a ceramic body and the lids shall be welded, brazed, preform-soldered or glass frit-sealed.



4.4.2 Lead Material and Finish

The lead material shall be Type 'D' with either Type '2' or Type '3 or 4' finish in accordance with ESA/SCC Basic Specification No. 23500 (See Table 1(a) for Type Variants).

4.5 MARKING

4.5.1 General

The marking of components delivered to this specification shall be in accordance with ESA/SCC Basic Specification No. 21700. Each component shall be marked in respect of:-

- (a) Lead Identification.
- (b) The SCC Component Number.
- (c) Traceability Information.

4.5.2 Lead Identification

An index shall be located at the top of the package in the position defined in Note 2 of Figure 2 (Variants 01, 02), Note 5 of Figure 2 (Variants 03, 04) or Note 6 of Figure 2 (Variants 05, 06). Alternatively, a tab may be used to identify Pin No. 1. The pin numbering shall be read with the index or tab on the left-hand side.

4.5.3 The SCC Component Number

Each component shall bear the SCC Component Number which shall be constituted and marked as follows:

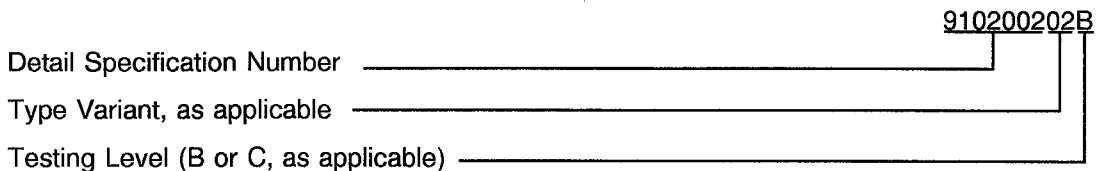

4.5.4 Traceability Information

Each component shall be marked in respect of traceability information in accordance with ESA/SCC Basic Specification No. 21700.

4.5.5 Marking of Small Components

When it is considered that the component is too small to accommodate the marking as specified above, as much as space permits shall be marked. The order of precedence shall be as follows:-

- (a) Lead Identification
- (b) The SCC Component Number.
- (c) Traceability Information.

The marking information in full shall accompany each component in its primary package.



4.6 ELECTRICAL CHARACTERISTICS

4.6.1 Electrical Measurements at Room Temperature

The parameters to be measured in respect of electrical characteristics are scheduled in Table 2. Unless otherwise specified, the measurements shall be performed at $T_{amb} = +22 \pm 3$ °C.

4.6.2 Electrical Measurements at High and Low Temperatures

The parameters to be measured at high and low temperatures are scheduled in Tables 3(a) and 3(b). The measurements shall be performed at $T_{amb} = +125$ °C and -55 °C respectively.

4.6.3 Circuits for Electrical Measurements

Circuits for use in performing the electrical measurements listed in Tables 2 and 3 of this specification are shown in Figure 4.

4.7 BURN-IN TESTS

4.7.1 Parameter Drift Values

The parameter drift values applicable to burn-in are specified in Table 4 of this specification. Unless otherwise stated, measurements shall be performed at $T_{amb} = +22 \pm 3$ °C. The parameter drift values (Δ) applicable to the parameters scheduled, shall not be exceeded. In addition to these drift value requirements, the appropriate limit value specified for a given parameter in Table 2 shall not be exceeded.

4.7.2 Conditions for Burn-in

The requirements for burn-in are specified in Section 7 of ESA/SCC Generic Specification No. 9000. The conditions for burn-in shall be as specified in Table 5 of this specification.

4.7.3 Electrical Circuits for Burn-in

Circuits for use in performing the burn-in tests are shown in Figure 5 of this specification.



TABLE 2 - ELECTRICAL MEASUREMENTS AT ROOM TEMPERATURE - d.c. PARAMETERS

| No. | Characteristics | Symbol | Test Method MIL-STD 883 | Test Fig. | Meas'd Value | Test Conditions | Limits | | Unit |
|-----|-------------------------------|------------------|-------------------------|-----------|---------------------|---|--------|-------|------|
| | | | | | | | Min | Max | |
| 1 | Output Regulation Coefficient | K _{VO1} | - | 4 | E ₁ (V) | V _{IN} = 8.5V, V _{OUT} = 5.0V I _L = 0mA, R _{SC} = 0 | - | 0.05 | % |
| | | | | | E ₂ (V) | V _{IN} = 8.5V, V _{OUT} = 5.0V I _L = 12mA, R _{SC} = 0 Note 1 | | | |
| 2 | Output Regulation Coefficient | K _{VO2} | - | 4 | E ₃ (V) | V _{IN} = 35V, V _{OUT} = 30V I _L = 0mA, R _{SC} = 0 | - | 0.05 | % |
| | | | | | E ₄ (V) | V _{IN} = 35V, V _{OUT} = 30V I _L = 12mA, R _{SC} = 0 Note 1 | | | |
| 3 | Output Regulation Coefficient | K _{VO3} | - | 4 | E ₅ (V) | V _{IN} = 43V, V _{OUT} = 40V I _L = 0mA, R _{SC} = 0 | - | 0.05 | % |
| | | | | | E ₆ (V) | V _{IN} = 43V, V _{OUT} = 40V I _L = 12mA, R _{SC} = 0 Note 1 | | | |
| 4 | Output Regulation Coefficient | K _{VO4} | - | 4 | E ₇ (V) | V _{IN} = 50V, V _{OUT} = 40V I _L = 0mA, R _{SC} = 0 | - | 0.05 | % |
| | | | | | E ₈ (V) | V _{IN} = 50V, V _{OUT} = 40V I _L = 12mA, R _{SC} = 0 Note 1 | | | |
| 5 | Input Regulation Coefficient | K _{VI1} | - | 4 | E ₉ (V) | V _{IN} = 8.5V, V _{OUT} = 5.0V I _L = 0, R _{SC} = 0 | - | 0.032 | %V |
| | | | | | E ₁₀ (V) | V _{IN} = 35V, V _{OUT} = 5.0V I _L = 0, R _{SC} = 0 Note 2 | | | |
| 6 | Input Regulation Coefficient | K _{VI2} | - | 4 | E ₁₁ (V) | V _{IN} = 8.5V, V _{OUT} = 5.0V I _L = 12mA, R _{SC} = 0 | - | 0.032 | %V |
| | | | | | E ₁₂ (V) | V _{IN} = 35V, V _{OUT} = 5.0V I _L = 12mA, R _{SC} = 0 Note 2 | | | |
| 7 | Input Regulation Coefficient | K _{VI3} | - | 4 | E ₁₃ (V) | V _{IN} = 43V, V _{OUT} = 40V I _L = 0, R _{SC} = 0 | - | 0.032 | %V |
| | | | | | E ₁₄ (V) | V _{IN} = 50V, V _{OUT} = 40V I _L = 0, R _{SC} = 0 Note 2 | | | |

NOTES: See Page 18.

**TABLE 2 - ELECTRICAL MEASUREMENTS AT ROOM TEMPERATURE - d.c. PARAMETERS (CONT'D)**

| No. | Characteristics | Symbol | Test Method MIL-STD 883 | Test Fig. | Meas'd Value | Test Conditions | Limits | | Unit |
|-----|---|-----------|-------------------------|-----------|--------------|---|--------|-------|------|
| | | | | | | | Min | Max | |
| 8 | Input Regulation Coefficient | K_{VI4} | - | 4 | E_{15} (V) | $V_{IN} = 43V, V_{OUT} = 40V$ $I_L = 12mA, R_{SC} = 0$ | - | 0.032 | %V |
| | | | | | E_{16} (V) | $V_{IN} = 50V, V_{OUT} = 40V$ $I_L = 12mA, R_{SC} = 0$ Note 2 | | | |
| 9 | Output Voltage | V_{OUT} | - | 4 | V_{OUT} | $V_{IN} = 8.5mA, V_{OUT} = 5.0V$ $I_L = 0 = R_{SC} = 0$ | 4.5 | 5.5 | V |
| 10 | Standby Current | I_Q | - | 4 | I_Q | $V_{IN} = 50V, V_{OUT} = 30V$ $I_L = -0.1mA$ | - | 2.0 | mA |
| 11 | Current Limit Sense Voltage without Boost | V_{SC} | - | 4 | V_{SC} | $V_{IN} = 8.5V, V_{OUT} = 0V$ $R_{SC} = 10\Omega$ | 225 | 400 | mV |
| 12 | Current Limit Sense Voltage without Boost | V_{SC} | - | 4 | V_{SC} | $V_{IN} = 30V, V_{OUT} = 0V$ $R_{SC} = 10\Omega$ | 225 | 400 | mV |

NOTES

1. Output regulation coefficient values are calculated as follows:-

$$K_{VO1} = \frac{E_1 - E_2}{100} \times 100; \quad K_{VO2} = \frac{E_3 - E_4}{E_3} \times 100;$$

$$K_{VO3} = \frac{E_5 - E_6}{E_5} \times 100; \quad K_{VO4} = \frac{E_7 - E_8}{E_7} \times 100.$$

2. Input regulation coefficient values are calculated as follows:-

$$K_{VI1} = \frac{\frac{(E_9 - E_{10})}{E_9} \times 100}{V_{IN}}; \quad K_{VI2} = \frac{\frac{(E_{11} - E_{14})}{E_{11}} \times 100}{V_{IN}};$$

$$K_{VI3} = \frac{\frac{(E_{13} - E_{14})}{E_{13}} \times 100}{\Delta V_{IN}}; \quad K_{VI4} = \frac{\frac{(E_{15} - E_{16})}{E_{15}} \times 100}{\Delta V_{IN}};$$



TABLE 3(a) - ELECTRICAL MEASUREMENTS AT HIGH TEMPERATURE, +125(+0 - 5) °C

| No. | Characteristics | Symbol | Test Method MIL-STD 883 | Test Fig. | Meas'd Value | Test Conditions | Limits | | Unit |
|-----|-------------------------------|------------------|-------------------------|-----------|---------------------|---|--------|-------|------|
| | | | | | | | Min | Max | |
| 1 | Output Regulation Coefficient | K _{VO1} | - | 4 | E ₁ (V) | V _{IN} = 8.5V, V _{OUT} = 5.0V I _L = 0mA, R _{SC} = 0 | - | 0.1 | % |
| | | | | | E ₂ (V) | V _{IN} = 8.5V, V _{OUT} = 5.0V I _L = 12mA, R _{SC} = 0 Note 1 | | | |
| 2 | Output Regulation Coefficient | K _{VO2} | - | 4 | E ₃ (V) | V _{IN} = 35V, V _{OUT} = 30V I _L = 0mA, R _{SC} = 0 | - | 0.1 | % |
| | | | | | E ₄ (V) | V _{IN} = 35V, V _{OUT} = 30V I _L = 12mA, R _{SC} = 0 Note 1 | | | |
| 3 | Output Regulation Coefficient | K _{VO3} | - | 4 | E ₅ (V) | V _{IN} = 43V, V _{OUT} = 40V I _L = 0mA, R _{SC} = 0 | - | 0.1 | % |
| | | | | | E ₆ (V) | V _{IN} = 43V, V _{OUT} = 40V I _L = 12mA, R _{SC} = 0 Note 1 | | | |
| 4 | Output Regulation Coefficient | K _{VO4} | - | 4 | E ₇ (V) | V _{IN} = 50V, V _{OUT} = 40V I _L = 0mA, R _{SC} = 0 | - | 0.1 | % |
| | | | | | E ₈ (V) | V _{IN} = 50V, V _{OUT} = 40V I _L = 12mA, R _{SC} = 0 Note 1 | | | |
| 5 | Input Regulation Coefficient | K _{VI1} | - | 4 | E ₉ (V) | V _{IN} = 8.5V, V _{OUT} = 5.0V I _L = 0, R _{SC} = 0 | - | 0.032 | %V |
| | | | | | E ₁₀ (V) | V _{IN} = 35V, V _{OUT} = 5.0V I _L = 0, R _{SC} = 0 Note 2 | | | |
| 6 | Input Regulation Coefficient | K _{VI2} | - | 4 | E ₁₁ (V) | V _{IN} = 8.5V, V _{OUT} = 5.0V I _L = 12mA, R _{SC} = 0 | - | 0.032 | %V |
| | | | | | E ₁₂ (V) | V _{IN} = 35V, V _{OUT} = 5.0V I _L = 12mA, R _{SC} = 0 Note 2 | | | |
| 7 | Input Regulation Coefficient | K _{VI3} | - | 4 | E ₁₃ (V) | V _{IN} = 43V, V _{OUT} = 40V I _L = 0, R _{SC} = 0 | - | 0.032 | %V |
| | | | | | E ₁₄ (V) | V _{IN} = 50V, V _{OUT} = 40V I _L = 0, R _{SC} = 0 Note 2 | | | |

NOTES: See Page 18.

**TABLE 3(a) - ELECTRICAL MEASUREMENTS AT HIGH TEMPERATURE, +125(+0 - 5) °C (CONT'D)**

| No. | Characteristics | Symbol | Test Method MIL-STD 883 | Test Fig. | Meas'd Value | Test Conditions | Limits | | Unit |
|-----|------------------------------|-----------|-------------------------|-----------|--------------|---|--------|-------|------|
| | | | | | | | Min | Max | |
| 8 | Input Regulation Coefficient | K_{VI4} | - | 4 | E_{15} (V) | $V_{IN} = 43V, V_{OUT} = 40V$ $I_L = 12mA, R_{SC} = 0$ | - | 0.032 | %V |
| | | | | | E_{16} (V) | $V_{IN} = 50V, V_{OUT} = 40V$ $I_L = 12mA, R_{SC} = 0$ Note 2 | | | |
| 9 | Output Voltage | V_{OUT} | - | 4 | V_{OUT} | $V_{IN} = 8.5mA, V_{OUT} = 5.0V$ $I_L = 0 = R_{SC} = 0$ | 4.5 | 5.5 | V |
| 10 | Standby Current | I_Q | - | 4 | I_Q | $V_{IN} = 50V, V_{OUT} = 30V$ $I_L = -0.1mA$ | - | 2.5 | mA |

NOTES: See Page 18.



TABLE 3(b) - ELECTRICAL MEASUREMENTS AT LOW TEMPERATURE, -55(+0 - 5) °C

| No. | Characteristics | Symbol | Test Method MIL-STD 883 | Test Fig. | Meas'd Value | Test Conditions | Limits | | Unit |
|-----|-------------------------------|------------------|-------------------------|-----------|---------------------|---|--------|-------|------|
| | | | | | | | Min | Max | |
| 1 | Output Regulation Coefficient | K _{VO1} | - | 4 | E ₁ (V) | V _{IN} = 8.5V, V _{OUT} = 5.0V I _L = 0mA, R _{SC} = 0 | - | 0.1 | % |
| | | | | | E ₂ (V) | V _{IN} = 8.5V, V _{OUT} = 5.0V I _L = 12mA, R _{SC} = 0 Note 1 | | | |
| 2 | Output Regulation Coefficient | K _{VO2} | - | 4 | E ₃ (V) | V _{IN} = 35V, V _{OUT} = 30V I _L = 0mA, R _{SC} = 0 | - | 0.1 | % |
| | | | | | E ₄ (V) | V _{IN} = 35V, V _{OUT} = 30V I _L = 12mA, R _{SC} = 0 Note 1 | | | |
| 3 | Output Regulation Coefficient | K _{VO3} | - | 4 | E ₅ (V) | V _{IN} = 43V, V _{OUT} = 40V I _L = 0mA, R _{SC} = 0 | - | 0.1 | % |
| | | | | | E ₆ (V) | V _{IN} = 43V, V _{OUT} = 40V I _L = 12mA, R _{SC} = 0 Note 1 | | | |
| 4 | Output Regulation Coefficient | K _{VO4} | - | 4 | E ₇ (V) | V _{IN} = 50V, V _{OUT} = 40V I _L = 0mA, R _{SC} = 0 | - | 0.1 | % |
| | | | | | E ₈ (V) | V _{IN} = 50V, V _{OUT} = 40V I _L = 12mA, R _{SC} = 0 Note 1 | | | |
| 5 | Input Regulation Coefficient | K _{VI1} | - | 4 | E ₉ (V) | V _{IN} = 8.5V, V _{OUT} = 5.0V I _L = 0, R _{SC} = 0 | - | 0.032 | %V |
| | | | | | E ₁₀ (V) | V _{IN} = 35V, V _{OUT} = 5.0V I _L = 0, R _{SC} = 0 Note 2 | | | |
| 6 | Input Regulation Coefficient | K _{VI2} | - | 4 | E ₁₁ (V) | V _{IN} = 8.5V, V _{OUT} = 5.0V I _L = 12mA, R _{SC} = 0 | - | 0.032 | %V |
| | | | | | E ₁₂ (V) | V _{IN} = 35V, V _{OUT} = 5.0V I _L = 12mA, R _{SC} = 0 Note 2 | | | |
| 7 | Input Regulation Coefficient | K _{VI3} | - | 4 | E ₁₃ (V) | V _{IN} = 43V, V _{OUT} = 40V I _L = 0, R _{SC} = 0 | - | 0.032 | %V |
| | | | | | E ₁₄ (V) | V _{IN} = 50V, V _{OUT} = 40V I _L = 0, R _{SC} = 0 Note 2 | | | |

NOTES: See Page 18.

**TABLE 3(b) - ELECTRICAL MEASUREMENTS AT LOW TEMPERATURE, -55(+0-5) °C (CONT'D)**

| No. | Characteristics | Symbol | Test Method MIL-STD 883 | Test Fig. | Meas'd Value | Test Conditions | Limits | | Unit |
|-----|------------------------------|-----------|-------------------------|-----------|--------------|---|--------|-------|------|
| | | | | | | | Min | Max | |
| 8 | Input Regulation Coefficient | K_{V14} | - | 4 | E_{15} (V) | $V_{IN} = 43V, V_{OUT} = 40V$ $I_L = 12mA, R_{SC} = 0$ | - | 0.032 | %V |
| | | | | | E_{16} (V) | $V_{IN} = 50V, V_{OUT} = 40V$ $I_L = 12mA, R_{SC} = 0$ Note 2 | | | |
| 9 | Output Voltage | V_{OUT} | - | 4 | V_{OUT} | $V_{IN} = 8.5mA, V_{OUT} = 5.0V$ $I_L = 0 = R_{SC} = 0$ | 4.5 | 5.5 | V |
| 10 | Standby Current | I_Q | - | 4 | I_Q | $V_{IN} = 50V, V_{OUT} = 30V$ $I_L = -0.1mA$ | - | 2.5 | mA |

NOTES: See Page 18.



FIGURE 4 - CIRCUITS FOR ELECTRICAL MEASUREMENTS

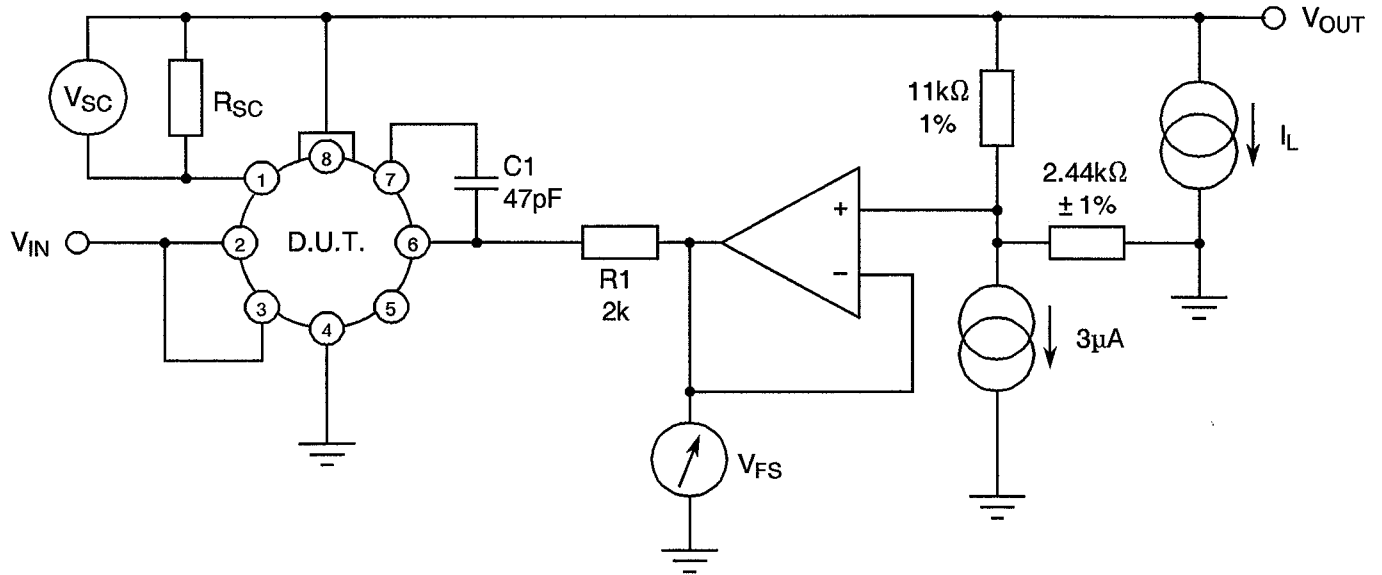



TABLE 4 - PARAMETER DRIFT VALUES

| No. | CHARACTERISTICS | SYMBOL | SPEC. AND/OR TEST METHOD | TEST CONDITIONS | CHANGE LIMITS (Δ) | UNIT |
|-----|--|------------------|--------------------------|-----------------|----------------------------|------|
| 5 | Change in Input Regulation Coefficient | ΔK_{VI} | As per Table 2 | As per Table 2 | ± 0.02 | %/V |
| 9 | Change in Output Voltage | ΔV_O | As per Table 2 | As per Table 2 | Note 1 | - |
| 10 | Change in Standby Current | $\Delta I_Q/I_Q$ | As per Table 2 | As per Table 2 | ± 10 | % |

NOTES

1. Absolute limits of 4.5V minimum and 5.5V maximum shall not be exceeded with test circuit No. 4.

TABLE 5 - CONDITIONS FOR BURN-IN

| No. | CHARACTERISTICS | SYMBOL | CONDITION | UNIT |
|-----|---------------------|----------------|--------------|-------------|
| 1 | Ambient Temperature | T_{amb} | $+125 \pm 5$ | $^{\circ}C$ |
| 2 | Power Supply | V_I V_O | +50 +40 | V |

FIGURE 5 - CIRCUIT FOR BURN-IN AND OPERATING LIFE TEST

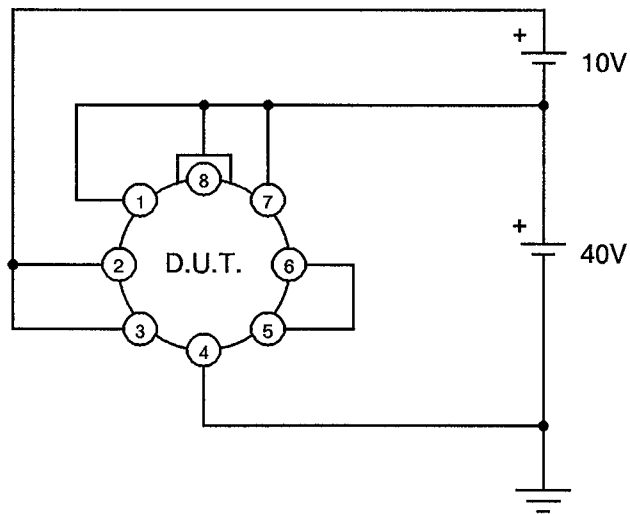



4.8 ENVIRONMENTAL AND ENDURANCE TESTS

4.8.1 Electrical Measurements on Completion of Environmental Tests

The parameters to be measured on completion of environmental tests are scheduled in Table 6. Unless otherwise stated, the measurements shall be performed at $T_{amb} = +22 \pm 3$ °C.

4.8.2 Electrical Measurements at Intermediate Points during Endurance Tests

The parameters to be measured at intermediate points during endurance tests are as scheduled in Table 6 of this specification.

4.8.3 Electrical Measurements on Completion of Endurance Tests

The parameters to be measured on completion of endurance testing are as scheduled in Table 6 of this specification. Unless otherwise stated, the measurements shall be performed at $T_{amb} = +22 \pm 3$ °C.

4.8.4 Conditions for Operating Life Tests

The requirements for operating life testing are specified in Section 9 of ESA/SCC Generic Specification No. 9000. The conditions for operating life testing shall be as specified in Table 5 of this specification.

4.8.5 Electrical Circuits for Operating Life Tests

Circuits for use in performing the operating life tests are shown in Figure 5.

4.8.6 Conditions for High Temperature Storage Test

The requirements for the high temperature storage test are specified in ESA/SCC Generic Specification No. 9000. The conditions for high temperature storage shall be $T_{amb} = +150 \pm 5$ °C.

**TABLE 6 - ELECTRICAL MEASUREMENTS ON COMPLETION OF ENVIRONMENTAL TESTS AND AT INTERMEDIATE POINTS AND ON COMPLETION OF ENDURANCE TESTING**

| No. | CHARACTERISTICS | SYMBOL | SPEC. AND/OR TEST METHOD | TEST CONDITIONS | LIMITS | | UNIT |
|-----|-------------------------------|----------|--------------------------|---|--------|-------|------|
| | | | | | MIN | MAX | |
| 1 | Output Regulation Coefficient | K_{VO} | 4 | $V_{IN} = 8.5V, V_O = 5.0V$ $0 \leq I_L \leq 12mA$ | - | 0.05 | % |
| 2 | Input Regulation Coefficient | K_{VI} | 4 | $I_L = 0, V_O = 5.0V$ $8.5 \leq V_{IN} \leq 35V$ | - | 0.032 | %/V |
| 3 | Output Voltage | V_O | 4 | $I_O = 0, V_{IN} = 8.5V$ $V_O = 5.0V$ | 4.5 | 5.5 | V |
| 4 | Standby Current | I_Q | 4 | $V_{IN} = 50V, V_O = 30V$ $I_O = 0.1mA$ | - | 2.0 | mA |