



european space agency
agence spatiale européenne

Pages 1 to 38

**INTEGRATED CIRCUITS, SILICON MONOLITHIC,
3-TERMINAL ADJUSTABLE
NEGATIVE REGULATOR,
BASED ON TYPE LM137**

ESA/SCC Detail Specification No. 9102/007





**space components
coordination group**

Issue/Rev.	Date	Approved by	
		SCCG Chairman	ESA Director General or his Deputy
Issue 1	September 1985	-	-
Revision 'A'	December 1991	<i>Pommes</i>	<i>J. Laif</i>
Revision 'B'	January 1993	<i>Pommes</i>	<i>J. Laif</i>
Revision 'C'	July 1993	<i>Pommes</i>	<i>J. Laif</i>



TABLE OF CONTENTS

	<u>Page</u>
1. GENERAL	6
1.1 Scope	6
1.2 Component Type Variants	6
1.3 Maximum Ratings	6
1.4 Parameter Derating Information	6
1.5 Physical Dimensions	6
1.6 Pin Assignment	6
1.7 Truth Table	6
1.8 Circuit Schematic	6
1.9 Functional Diagram	6
2. APPLICABLE DOCUMENTS	13
3. TERMS, DEFINITIONS, ABBREVIATIONS, SYMBOLS AND UNITS	13
4. REQUIREMENTS	13
4.1 General	13
4.2 Deviations from Generic Specification	13
4.2.1 Deviations from Special In-process Controls	13
4.2.2 Deviations from Final Production Tests (Chart II)	13
4.2.3 Deviations from Burn-in Tests (Chart III)	14
4.2.4 Deviations from Qualification, Environmental and Endurance Tests (Chart IV)	14
4.2.5 Deviations from Lot Acceptance Tests (Chart V)	14
4.3 Mechanical Requirements	14
4.3.1 Dimension Check	14
4.3.2 Weight	14
4.4 Materials and Finishes	14
4.4.1 Case	15
4.4.2 Lead Material and Finish	15
4.5 Marking	15
4.5.1 General	15
4.5.2 Lead Identification	15
4.5.3 The SCC Component Number	15
4.5.4 Traceability Information	15
4.5.5 Marking of Small Components	16

		<p style="text-align: center;">ESA/SCC Detail Specification No. 9102/007</p>		<p>PAGE 4 ISSUE 1</p>
--	--	--	--	---------------------------

	<u>Page</u>
4.6 Electrical Characteristics	16
4.6.1 Electrical Measurements at Room Temperature	16
4.6.2 Electrical Measurements at High and Low Temperatures	16
4.6.3 Circuits for Electrical Measurements	16
4.7 Burn-in Tests	16
4.7.1 Parameter Drift Values	16
4.7.2 Conditions for Power Burn-in	17
4.7.3 Electrical Circuits for Power Burn-in	17
4.8 Environmental and Endurance Tests	36
4.8.1 Electrical Measurements on Completion of Environmental Tests	36
4.8.2 Electrical Measurements at Intermediate Points During Endurance Tests	36
4.8.3 Electrical Measurements on Completion of Endurance Tests	36
4.8.4 Conditions for Operating Life Tests	36
4.8.5 Electrical Circuits for Operating Life Tests	36
4.8.6 Conditions for High Temperature Storage Test	36

TABLES

1(a) Type Variants	7
1(b) Maximum Ratings	7
2 Electrical Measurements at Room Temperature, d.c. Parameters	18
Electrical Measurements at Room Temperature, a.c. Parameters	21
3 Electrical Measurements at High and Low Temperatures	23
4 Parameter Drift Values	35
5 Conditions for Burn-in	35
6 Electrical Measurements on Completion of Environmental Tests and at Intermediate Points and on Completion of Environmental Testing	37

FIGURES

1 Device Dissipation Derating with Temperature	8
2 Physical Dimensions	9
3(a) Pin Assignment	11
3(b) Not Applicable	N/A
3(c) Circuit Schematic	12
3(d) Functional Diagram	12



	<u>Page</u>
4(a) Output Load Conditions	26
4(b) Reference Voltage, Line Regulation, Load Regulation and Thermal Regulation Voltage	27
4(c) Adjust Pin Current	29
4(d) Minimum Load Current	29
4(e) Output Short Circuit Current	30
4(f) Output Voltage Recovery after Output Short Circuit Current and Start-up Voltage	31
4(g) Ripple Rejection	31
4(h) Line Transient Response	32
4(i) Load Transient Response	33
4(j) Output Noise Voltage	34
5 Circuit for Burn-in and Operating Life Test	35

APPENDICES (Applicable to specific Manufacturers only)

'A' Agreed Deviations for Motorola (F)	38
--	----

**1. GENERAL****1.1 SCOPE**

This specification details the ratings, physical and electrical characteristics, test and inspection data for a silicon monolithic, 3-Terminal Adjustable Negative Regulator, based on Type LM137. It shall be read in conjunction with ESA/SCC Generic Specification No. 9000, the requirements of which are supplemented herein.

1.2 COMPONENT TYPE VARIANTS

Variants of the basic type integrated circuits specified herein, which are also covered by this specification, are given in Table 1(a).

1.3 MAXIMUM RATINGS

The maximum ratings, which shall not be exceeded at any time during use or storage, applicable to the integrated circuits specified herein, are as scheduled in Table 1(b).

1.4 PARAMETER DERATING INFORMATION

As per Figure 1.

1.5 PHYSICAL DIMENSIONS

The physical dimensions of the integrated circuits specified herein are shown in Figure 2.

1.6 PIN ASSIGNMENT

As per Figure 3(a).

1.7 TRUTH TABLE (FIGURE 3(b))

Not applicable.

1.8 CIRCUIT SCHEMATIC

As per Figure 3(c).

1.9 FUNCTIONAL DIAGRAM

As per Figure 3(d).



TABLE 1(a) - TYPE VARIANTS

VARIANT	CASE	FIGURE	LEAD MATERIAL AND/OR FINISH
-01	TO3	2(a)	D2
-02	TO3	2(a)	D3 or D4
-03	TO39	2(b)	D2
-04	TO39	2(b)	D3 or D4
-05	TO3	2(a)	F9
-06	TO39	2(b)	D9

TABLE 1(b) - MAXIMUM RATINGS

No.	CHARACTERISTICS	SYMBOL	MAXIMUM RATINGS	UNITS	REMARKS
1	Input-Output Voltage Difference	$V_{IN}-V_{OUT}$	40	V	
2	Device Dissipation Variants -01, -02, -05 Variants -03, -04, -06	P_{DISS}	3.6 0.89	W	Note 1
3	Device Dissipation Variants -01, -02, -05 Variants -03, -04, -06	P_{DISS}	28 2.5	W	Note 2
4	Operating Temperature Range	T_{op}	- 55 to +125	°C	
5	Storage Temperature Range	T_{stg}	- 65 to +150	°C	
6	Soldering Temperature	T_{sol}	+ 300	°C	Note 3
7	Junction Temperature	T_j	+ 150	°C	Note 4

NOTES

1. At $T_{amb} < +25^{\circ}C$ without heatsink. For Device derating with temperature, see Figure 1.
2. At $T_{case} > +25^{\circ}C$ with a maximum thermal heatsink impedance of 0.5 °C/W for Variants -01, -02, -05 and 10°C/W for Variants -03, -04, -06. For Device derating with temperature, see Figure 1.
3. Duration 10 seconds maximum at a distance of not less than 1.5mm from the can and the same lead shall not be resoldered until 3 minutes have elapsed.
4. Internally limited to +150°C maximum by a thermal shutdown circuit.

FIGURE 1 - DEVICE DISSIPATION DERATING WITH TEMPERATURE

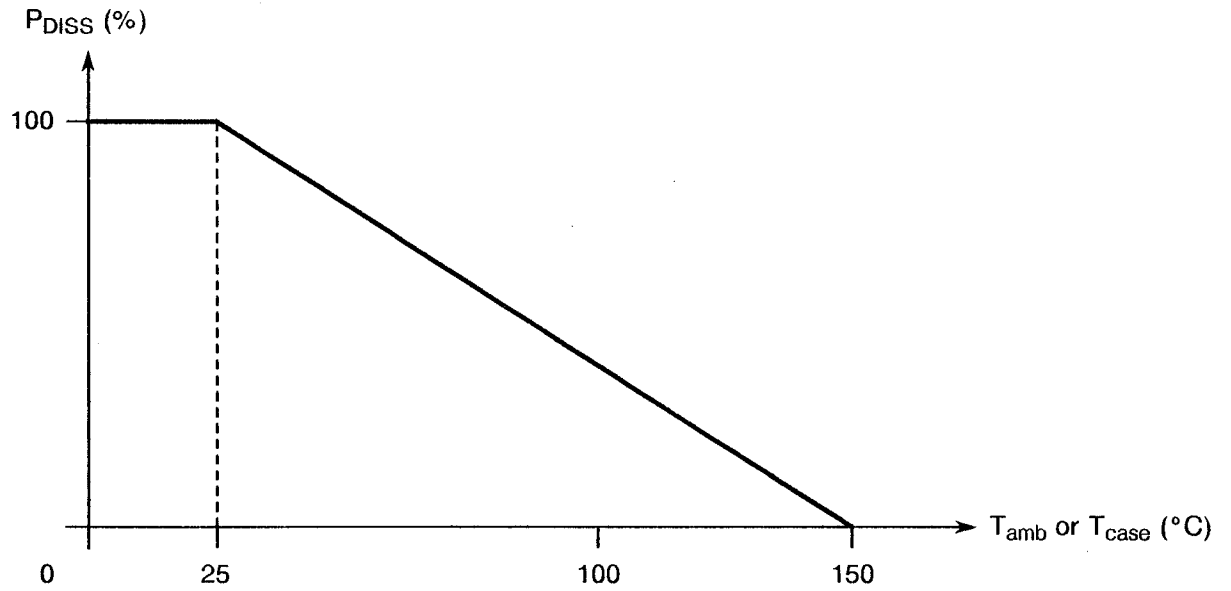
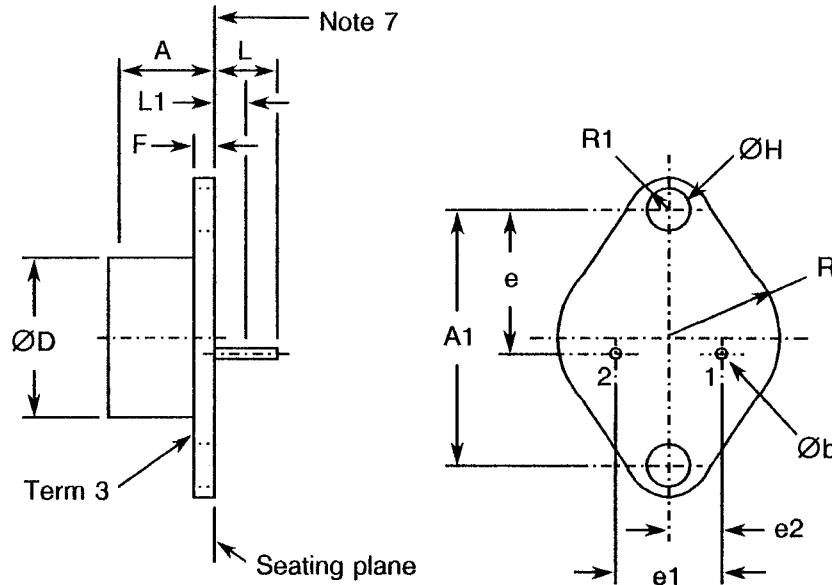



FIGURE 2 - PHYSICAL DIMENSIONS

FIGURE 2(a) - TO3 PACKAGE



SYMBOL	DIMENSIONS				NOTES
	MILLIMETRES		INCHES		
	MIN.	MAX.	MIN.	MAX.	
A	6.35	11.43	0.250	0.450	
A1	29.90	30.40	1.177	1.197	
Øb	0.97	1.09	0.038	0.043	3, 7
ØD	-	22.22	-	0.875	
e	16.64	17.14	0.655	0.675	
e1	10.67	11.18	0.420	0.440	
e2	5.21	5.72	0.205	0.225	
F	1.52	3.43	0.060	0.135	
ØH	3.84	4.09	0.151	0.161	5, 6
L	7.92	12.70	0.312	0.500	4
L1	-	1.27	-	0.050	3, 4
R	12.57	13.34	0.495	0.525	
R1	3.33	4.78	0.131	0.188	

NOTES

- Dimensions shall be measured in millimetres.
- Equivalents in inches are given for general information only and are based upon 25.4mm = 1.00 inch.
- (2 leads) Øb applies between L1 and 12.70mm (0.500) from the seating plane. Diameter is uncontrolled in L1 and beyond 12.70mm (0.500) from the seating plane.
- 2 leads.
- 2 holes.
- 2 holes located at true position within diameter 0.25mm (0.010).
- Leads having a maximum diameter of 1.09mm (0.043) measured in gauging plane 1.37mm (0.054) + 0.03mm (0.001) - 0.00mm (0.000) below the seating plane shall be located at true position within diameter 0.36mm (0.014).
- The mounting surface of the header shall be flat to convex within 0.08mm (0.003) inside a 23.62mm (0.930) diameter circle on the centre of the header and flat to convex within 0.15mm (0.006) overall.



FIGURE 2 - PHYSICAL DIMENSIONS (CONTINUED)

FIGURE 2(b) - TO39 PACKAGE

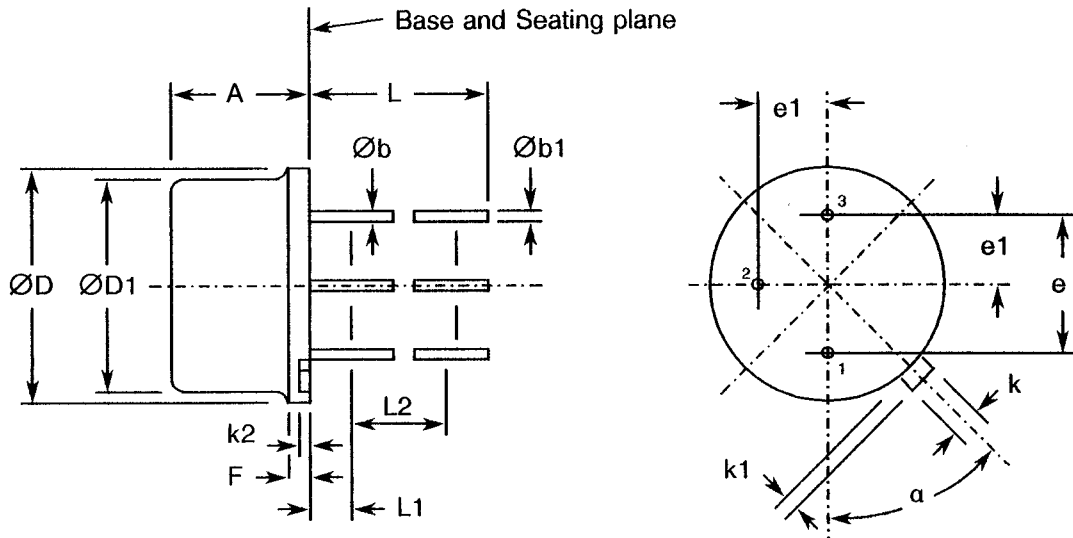

SYMBOL	MILLIMETRES		INCHES		NOTES
	MIN.	MAX.	MIN.	MAX.	
A	4.19	4.70	0.165	0.185	
Øb	0.41	0.48	0.016	0.019	3
Øb1	0.41	0.53	0.016	0.021	3
ØD	8.51	9.40	0.335	0.370	
ØD1	7.75	8.51	0.305	0.335	
e	5.08 TYP		0.200 TYP		5
e1	2.54 TYP		0.100 TYP		5
F	-	1.27	-	0.050	
k	0.71	0.86	0.028	0.034	
k1	0.74	1.14	0.029	0.045	4
k2	0.23	1.04	0.009	0.041	
L	12.70	-	0.500	-	
L1	-	1.27	-	0.050	
L2	6.35	-	0.250	-	
α	45° TYP		45° TYP		5

NOTES

1. Dimensions shall be measured in millimetres.
2. Equivalents in inches are given for general information only and are based upon 25.4mm = 1.00 inch.
3. (3 leads) Øb applies between L1 and L2. Øb1 applies between L2 and 12.70mm (0.500) from the reference plane. Diameter is uncontrolled in L1 and beyond 12.70mm (0.500) from the reference plane.
4. 3 leads.
5. Measured from the maximum diameter of the product.
6. Leads having a maximum diameter of 0.48mm (0.019) measured in gauging plane 1.37mm (0.054) + 0.03mm (0.001) - 0.00mm (0.000) below the base plane of the product shall be within 0.18mm (0.007) of their true position relative to a maximum width tab.
7. The product may be measured by direct methods or by gauge.



FIGURE 3(a) - PIN ASSIGNMENT

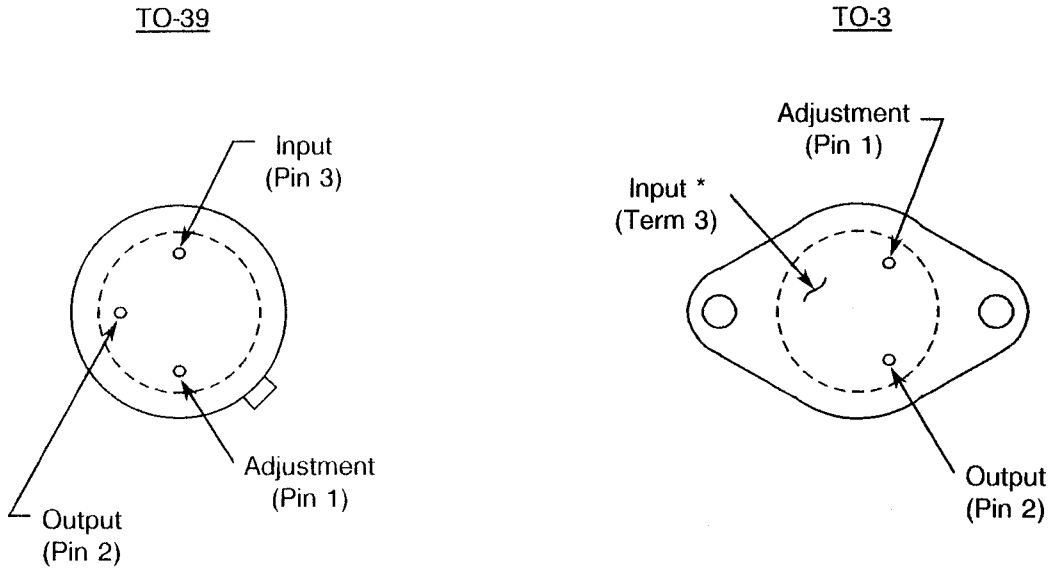

BOTTOM VIEWS

NOTES

1. Case is connected to input.



FIGURE 3(c) - CIRCUIT SCHEMATIC

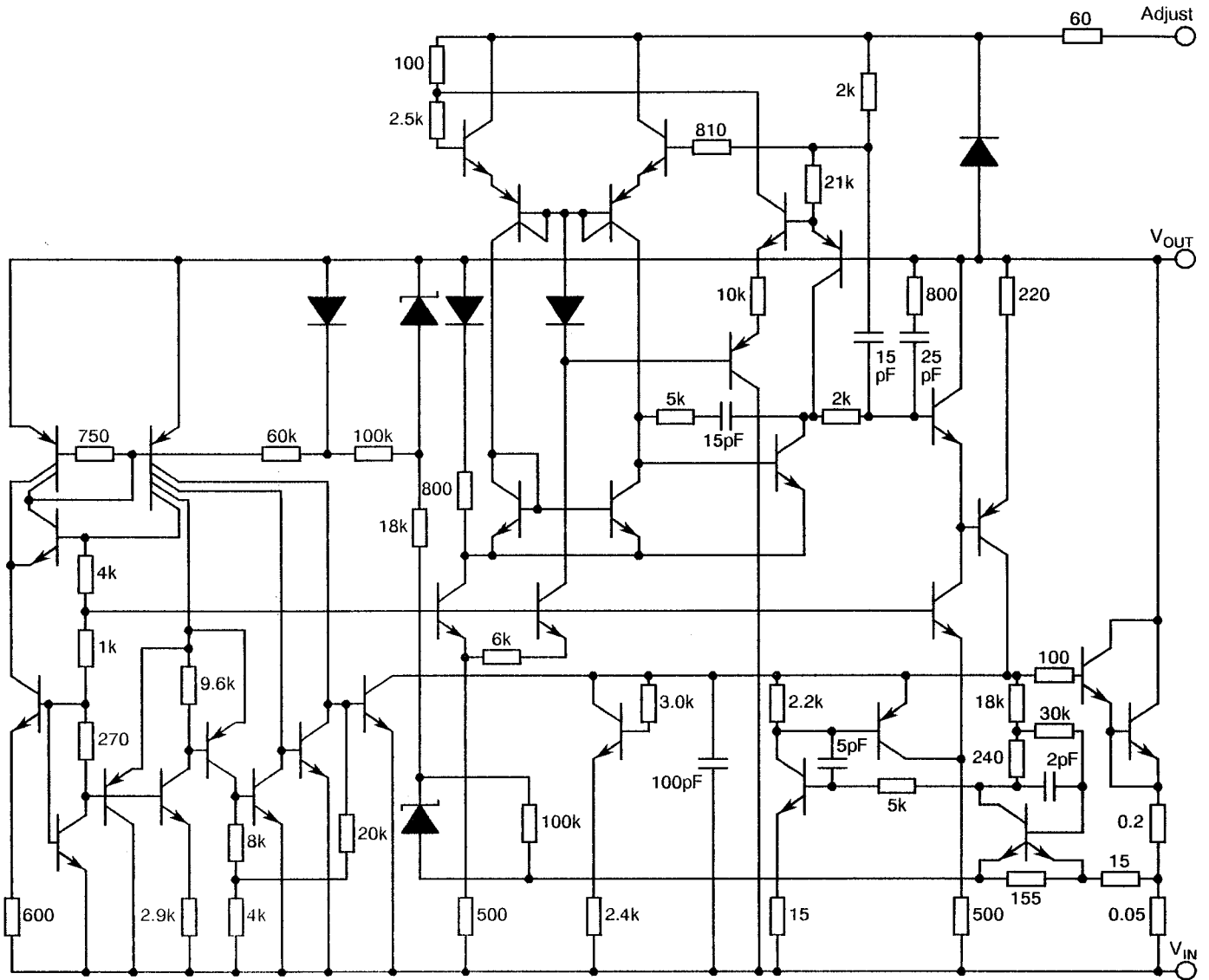

NOTES

- 1. Resistor values are nominal and in ohms.

FIGURE 3(d) - FUNCTIONAL DIAGRAM

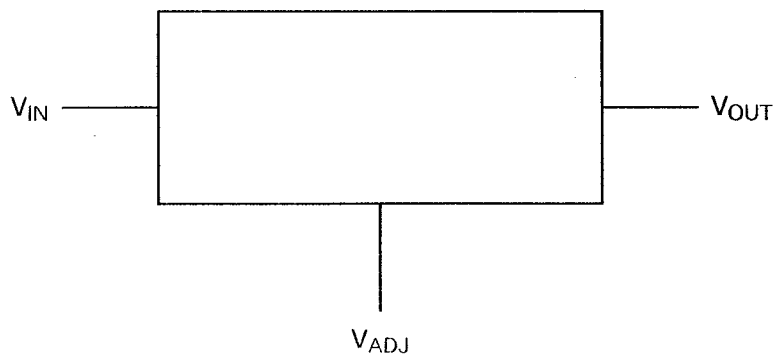



2. APPLICABLE DOCUMENTS

The following documents form part of this specification and shall be read in conjunction with it:-

- (a) ESA/SCC Generic Specification No. 9000 for Integrated Circuits.
- (b) MIL-STD-883, Test Methods and Procedures for Micro-electronics.

3. TERMS, DEFINITIONS, ABBREVIATIONS, SYMBOLS AND UNITS

For the purpose of this specification, the terms, definitions, abbreviations, symbols and units specified in ESA/SCC Basic Specification No. 21300 shall apply. In addition, the following abbreviations are used:-

- V_{REF} = Reference Voltage.
- V_{RLINE} = Line Regulation.
- V_{RLOAD} = Load Regulation.
- I_{ADJ} = Adjustment Current.
- I_{OUT} = Current Limit Min. Load Current.

4. REQUIREMENTS

4.1 GENERAL

The complete requirements for procurement of the integrated circuits specified herein are stated in this specification and ESA/SCC Generic Specification No. 9000 for Integrated Circuits. Deviations from the Generic Specification applicable to this specification only, are listed in Para. 4.2.

Deviations from the applicable Generic Specification and this Detail Specification, formally agreed with specific Manufacturers on the basis that the alternative requirements are equivalent to the ESA/SCC requirements and do not affect the components' reliability, are listed in the appendices attached to this specification.

4.2 DEVIATIONS FROM GENERIC SPECIFICATION

The following deviations from ESA/SCC Generic Specification No. 9000 shall apply:-

4.2.1 Deviations from Special In-process Controls

None.

4.2.2 Deviations from Final Production Tests (Chart II)

None.

**4.2.3 Deviations from Burn-in Tests (Chart III)**

High Temperature Reverse Bias test and subsequent electrical measurements related to this test shall not be performed.

4.2.4 Deviations from Qualification, Environmental and Endurance Tests (Chart IV)

None.

4.2.5 Deviations from Lot Acceptance Tests (Chart V)

None.

4.3 MECHANICAL REQUIREMENTS**4.3.1 Dimension Check**

The dimensions of the integrated circuits specified herein shall be checked. They shall conform to those shown in Figure 2.

4.3.2 Weight

The maximum weight of the integrated circuits specified herein shall be for:-

Variants 01, 02, 05: 12.5 grammes.

Variants 03, 04, 06: 1.1 grammes.

4.4 MATERIALS AND FINISHES

The materials and finishes shall be as specified herein. Where a definite material is not specified, a material which will enable the integrated circuits specified herein to meet the performance requirements of this specification shall be used. Acceptance or approval of any constituent material does not guarantee acceptance of the finished product.



4.4.1 Case

The case shall be hermetically sealed and have a metal body with hard glass seals and the lids shall be welded, brazed or preform-soldered.

4.4.2 Lead Material and Finish

The lead material shall be either Type 'D' or Type 'F' with either Type '2', Type '3 or 4' or Type '9' finish in accordance with ESA/SCC Basic Specification No. 23500 (See Table 1(a) for Type Variants).

4.5 MARKING

4.5.1 General

The marking of components delivered to this specification shall be in accordance with ESA/SCC Basic Specification No. 21700. Each component shall be marked in respect of:-

- (a) Lead Identification.
- (b) The SCC Component Number.
- (c) Traceability Information.

4.5.2 Lead Identification

The lead identification shall be as defined in Figure 3(a).

4.5.3 The SCC Component Number

Each component shall bear the SCC Component Number which shall be constituted and marked as follows:

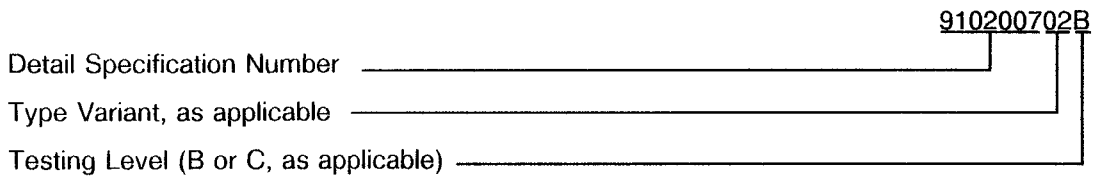

4.5.4 Traceability Information

Each component shall be marked in respect of traceability information in accordance with ESA/SCC Basic Specification No. 21700.



4.5.5 Marking of Small Components

When it is considered that the component is too small to accommodate the marking as specified above, as much as space permits shall be marked. The order of precedence shall be as follows:-

- (a) Lead Identification.
- (b) The SCC Component Number.
- (c) Traceability Information.

The marking information in full shall accompany each component in its primary package.

4.6 ELECTRICAL CHARACTERISTICS

4.6.1 Electrical Measurements at Room Temperature

The parameters to be measured in respect of electrical characteristics are scheduled in Table 2. Unless otherwise specified, the measurements shall be performed at $T_{amb} = +22 \pm 3$ °C.

4.6.2 Electrical Measurements at High and Low Temperatures

The parameters to be measured at high and low temperatures are scheduled in Tables 3(a) and 3(b). The measurements shall be performed at $T_{amb} = +125$ °C and -55 °C respectively.

4.6.3 Circuits for Electrical Measurements

Circuits for use in performing the electrical measurements listed in Tables 2 and 3 of this specification are shown in Figure 4.

4.7 BURN-IN TESTS

4.7.1 Parameter Drift Values

The parameter drift values applicable to burn-in are specified in Table 4 of this specification. Unless otherwise stated, measurements shall be performed at $T_{amb} = +22 \pm 3$ °C. The parameter drift values (Δ) applicable to the parameters scheduled, shall not be exceeded. In addition to these drift value requirements, the appropriate limit value specified for a given parameter in Table 2 shall not be exceeded.



4.7.2 Conditions for Power Burn-in

The requirements for power burn-in are specified in Section 7 of ESA/SCC Generic Specification No. 9000. The conditions for power burn-in shall be as specified in Table 5 of this specification.

4.7.3 Electrical Circuits for Power Burn-in

Circuits for use in performing the power burn-in tests are shown in Figure 5 of this specification.



TABLE 2 - ELECTRICAL MEASUREMENTS AT ROOM TEMPERATURE - d.c. PARAMETERS

Test No.	Characteristics	Symbol	Meas'd Value	Test Fig.	Variant	Test Conditions (Notes 1 and 2)	Limits		Unit
							Min	Max	
1	Reference Voltage 1	V _{REF1}	E ₁ (V)	4(b)	All	V _{IN} = - 4.25V I _{OUT} = 5.0mA	- 1.275	- 1.225	V
2	Reference Voltage 2	V _{REF2}	E ₂ (V)	4(b)	03, 04 and 06	V _{IN} = - 4.25V I _{OUT} = 0.5A	- 1.275	- 1.225	V
			E ₃ (V)		01, 02 and 05	V _{IN} = - 4.25V I _{OUT} = 1.5A			
3	Reference Voltage 3	V _{REF3}	E ₄ (V)	4(b)	All	V _{IN} = - 41.25V I _{OUT} = 5.0mA	- 1.275	- 1.225	V
4	Reference Voltage 4	V _{REF4}	E ₅ (V)	4(b)	03, 04 and 06	V _{IN} = - 41.25V I _{OUT} = 50mA	- 1.275	- 1.225	V
			E ₆ (V)		01, 02 and 05	V _{IN} = - 41.25V I _{OUT} = 150mA			
5	Line Regulation	V _{RLINE}	E ₁ - E ₄ (V)	4(b)	All	- 41.25V < V _{IN} < - 4.25V I _{OUT} = 5.0mA V _{OUT} = V _{REF}	- 9.0	9.0	mV
6	Load Regulation 1	V _{RLOAD1}	E ₄ - E ₅ (V)	4(b)	03, 04 and 06	V _{IN} = - 41.25V V _{OUT} = V _{REF} 5.0mA < I _{OUT} < 50mA	- 6.0	6.0	mV
			E ₄ - E ₆ (V)		01, 02 and 05	V _{IN} = - 41.25V V _{OUT} = V _{REF} 5.0mA < I _{OUT} < 150mA			
7	Load Regulation 2	V _{RLOAD2}	E ₇ (V)	4(b)	All	V _{IN} = - 6.25V I _{OUT} = 5.0mA V _{OUT} = V _{REF}	- 15	15	mV
			E ₈ (V)		03, 04 and 06	V _{IN} = - 6.25V I _{OUT} = 0.5A V _{OUT} = V _{REF}			
			E ₉ (V)		01, 02 and 05	V _{IN} = - 6.25V I _{OUT} = 1.5A V _{OUT} = V _{REF}			
8	Adjust Pin Current 1	I _{ADJ1}	A ₁ (V)	4(c)	All	V _{IN} = - 4.25V I _{OUT} = 5.0mA V _{OUT} = V _{REF}	25	100	μA
9	Adjust Pin Current 2	I _{ADJ2}	A ₂ (V)	4(c)	All	V _{IN} = - 41.25V I _{OUT} = 5.0mA V _{OUT} = V _{REF}	25	100	μA

NOTES: See Page 22.



TABLE 2 - ELECTRICAL MEASUREMENTS AT ROOM TEMPERATURE - d.c. PARAMETERS (CONT'D)

Test No.	Characteristics	Symbol	Meas'd Value	Test Fig.	Variant	Test Conditions (Notes 1 and 2)	Limits		Unit
							Min	Max	
10	Adjust Pin Current Change A	ΔI_{ADJA}	$I_{ADJ1} - I_{ADJ2}$	-	All	-	-5.0	5.0	μA
11	Adjust Pin Current Change B	ΔI_{ADJB}	A_3 (V)	4(c)	All	$V_{IN} = -6.25V$ $I_{OUT} = 5.0mA$ $V_{OUT} = V_{REF}$	-5.0	5.0	μA
			A_4 (V)		03, 04 and 06	$V_{IN} = -6.25V$ $I_{OUT} = 0.5A$ $V_{OUT} = V_{REF}$			
			A_5 (V)		01, 02 and 05	$V_{IN} = -6.25V$ $I_{OUT} = 1.5A$ $V_{OUT} = V_{REF}$			
12	Minimum Load Current 1	I_{OUT1}	I_6 (mA)	4(d)	All	$V_{IN} = -4.25V$ $V_{OUT} = V_{REF}$ Note 3	0.2	5.0	mA
13	Minimum Load Current 2	I_{OUT2}	I_7 (mA)	4(d)	All	$V_{IN} = -14.25V$ $V_{OUT} = V_{REF}$ Note 3	0.2	5.0	mA
14	Minimum Load Current 3	I_{OUT3}	I_8 (mA)	4(d)	All	$V_{IN} = -41.25V$ $V_{OUT} = V_{REF}$ Note 3	1.0	5.0	mA
15	Output Short Circuit Current 1	I_{OS1}	B_1 (A)	4(e)	All	$V_{IN} = -4.25V$	1.5	3.5	A
16	Output Short Circuit Current 2	I_{OS2}	B_2 (A)	4(e)	All	$V_{IN} = -40V$	0.2	0.8	A
17	Output Voltage Recovery 1 After Output Short Circuit Current	V_{RECOV1}	E_{10} (V)	4(f)	All	$V_{IN} = -4.25V$ $I_{OUT} = 0.5A$	-1.3	-1.2	V
18	Output Voltage Recovery 2 After Output Short Circuit Current	V_{RECOV2}	E_{11} (V)	4(f)	All	$V_{IN} = -40V$ $I_{OUT} = 5.0mA$	-1.3	-1.2	V

NOTES: See Page 22.

**TABLE 2 - ELECTRICAL MEASUREMENTS AT ROOM TEMPERATURE - d.c. PARAMETERS (CONT'D)**

Test No.	Characteristics	Symbol	Meas'd Value	Test Fig.	Variant	Test Conditions (Notes 1 and 2)	Limits		Unit
							Min	Max	
19	Start-Up Voltage	V _{START}	E ₁₂ (V)	4(f)	03, 04 and 06	V _{IN} = - 4.25V I _{OUT} = 0.5A	- 1.3	- 1.2	V
					01, 02 and 05	V _{IN} = - 4.25V I _{OUT} = 1.5A			
20	Thermal Regulation Voltage	V _{RTH}	E ₁₃ (V)	4(b)	03, 04 and 06	V _{IN} = - 14.25V I _{OUT} = 0.5A t = 0	- 5.0	5.0	mV
			E ₁₄ (V)			V _{IN} = - 14.25V I _{OUT} = 0.5A t = 20ms			
			E ₁₅ (V)		01, 02 and 05	V _{IN} = - 14.25V I _{OUT} = 1.5A t = 0ms			
			E ₁₆ (V)			V _{IN} = - 14.25V I _{OUT} = 1.5A t = 20ms			

NOTES: See Page 22.



TABLE 2 - ELECTRICAL MEASUREMENTS AT ROOM TEMPERATURE - a.c. PARAMETERS

Test No.	Characteristics	Symbol	Meas'd Value	Test Fig.	Variant	Test Conditions (Notes 1 and 2)	Limits		Unit
							Min	Max	
21	Ripple Rejection	RR	E ₀₁ (Vrms)	4(g)	03, 04 and 06	V _{IN} = -6.25V E _{IN} = 1.0Vrms I _L = 125mA f = 2400Hz	40	-	dB
			E ₀₂ (Vrms)		01, 02 and 05	V _{IN} = -6.25V E _{IN} = 1.0Vrms I _L = 0.5mA f = 2400Hz			
22	Line Transient Response	LTR ₁	ΔV _{OUT1} (mV)	4(h)	All	V _{IN} = -6.25V I _L = 10mA ΔV _{IN} = 3.0V V _{OUT} = V _{REF}	-	350	mV/V
23	Load Transient Response	LTR ₂	ΔV _{OUT2} (mV)	4(i)	03, 04 and 06	V _{IN} = -6.25V V _{OUT} = V _{REF} I _L = 100mA to 500mA	-	0.3	mV/ mA
			ΔV _{OUT3} (mV)		01, 02 and 05	V _{IN} = -6.25V V _{OUT} = V _{REF} I _L = 50mA to 250mA			
24	Output Noise Voltage	V _{NO}	E ₀₁ (Vrms)	4(j)	03, 04 and 06	V _{IN} = -6.25V I _L = 100mA V _{OUT} = V _{REF}	-	120	μV rms
			E ₀₂ (Vrms)		01, 02 and 05	V _{IN} = -6.25V I _L = 50mA V _{OUT} = V _{REF}			

NOTES: See Page 22.

**TABLE 2 - ELECTRICAL MEASUREMENTS AT ROOM TEMPERATURE (CONT'D)****NOTES**

1. All input voltages shall be applied directly to the device input pin.
2. The output load current conditions shall be applied as defined in Figure 4(a)
3. Decrease I_i from the maximum limit until the reference voltage E_i becomes higher than the initial E_i value of +50mV.
N.B. This I_i value is defined as the minimum load current value. The initial value of E_i is measured when I_i equals the maximum limit value.
4. Measurements performed on a sample basis LTPD7, or less.



**TABLE 3 - ELECTRICAL MEASUREMENTS AT HIGH AND LOW TEMPERATURES,
+ 125(+ 0 - 5)°C AND - 55(+ 5 - 0)°C**

Test No.	Characteristics	Symbol	Meas'd Value	Test Fig.	Variant	Test Conditions (Notes 1 and 2)	Limits		Unit
							Min	Max	
1	Reference Voltage 1	V _{REF1}	E ₁ (V)	4(b)	All	V _{IN} = - 4.25V I _{OUT} = 5.0mA	- 1.3	- 1.2	V
2	Reference Voltage 2	V _{REF2}	E ₂ (V)	4(b)	03, 04 and 06	V _{IN} = - 4.25V I _{OUT} = 0.5A	- 1.3	- 1.2	V
			E ₃ (V)		01, 02 and 05	V _{IN} = - 4.25V I _{OUT} = 1.5A			
3	Reference Voltage 3	V _{REF3}	E ₄ (V)	4(b)	All	V _{IN} = - 41.25V I _{OUT} = 5.0mA	- 1.3	- 1.2	V
4	Reference Voltage 4	V _{REF4}	E ₅ (V)	4(b)	03, 04 and 06	V _{IN} = - 41.25V I _{OUT} = 50mA	- 1.3	- 1.2	V
			E ₆ (V)		01, 02 and 05	V _{IN} = - 41.25V I _{OUT} = 150mA			
5	Line Regulation	V _{RLINE}	E ₁ - E ₄ (V)	4(b)	All	- 41.25V < V _{IN} < - 4.25V I _{OUT} = 5.0mA V _{OUT} = V _{REF}	- 23	23	mV
6	Load Regulation 1	V _{RLOAD1}	E ₄ - E ₅ (V)	4(b)	03, 04 and 06	V _{IN} = - 41.25V V _{OUT} = V _{REF} 5.0mA < I _{OUT} < 50mA	- 36	36	mV
			E ₄ - E ₆ (V)		01, 02 and 05	V _{IN} = - 41.25V V _{OUT} = V _{REF} 5.0mA < I _{OUT} < 150mA			
7	Load Regulation 2	V _{RLOAD2}	E ₇ (V)	4(b)	All	V _{IN} = - 6.25V I _{OUT} = 5.0mA V _{OUT} = V _{REF}	- 36	36	mV
			E ₈ (V)		03, 04 and 06	V _{IN} = - 6.25V I _{OUT} = 0.5A V _{OUT} = V _{REF}			
			E ₉ (V)		01, 02 and 05	V _{IN} = - 6.25V I _{OUT} = 1.5A V _{OUT} = V _{REF}			
8	Adjust Pin Current 1	I _{ADJ1}	A ₁ (V)	4(c)	All	V _{IN} = - 4.25V I _{OUT} = 5.0mA V _{OUT} = V _{REF}	25	100	μA
9	Adjust Pin Current 2	I _{ADJ2}	A ₂ (V)	4(c)	All	V _{IN} = - 41.25V I _{OUT} = 5.0mA V _{OUT} = V _{REF}	25	100	μA

NOTES: See Page 22.

**TABLE 3 - ELECTRICAL MEASUREMENTS AT HIGH AND LOW TEMPERATURES,
+ 125(+ 0 - 5)°C AND - 55(+ 5 - 0)°C (CONT'D)**

Test No.	Characteristics	Symbol	Meas'd Value	Test Fig.	Variant	Test Conditions (Notes 1 and 2)	Limits		Unit
							Min	Max	
10	Adjust Pin Current Change A	ΔI_{ADJA}	$I_{ADJ1} - I_{ADJ2}$	-	All	-	- 5.0	5.0	μA
11	Adjust Pin Current Change B	ΔI_{ADJB}	A_3 (V)	4(c)	All	$V_{IN} = - 6.25V$ $I_{OUT} = 5.0mA$ $V_{OUT} = V_{REF}$	- 5.0	5.0	μA
			A_4 (V)		03, 04 and 06	$V_{IN} = - 6.25V$ $I_{OUT} = 0.5A$ $V_{OUT} = V_{REF}$			
			A_5 (V)		01, 02 and 05	$V_{IN} = - 6.25V$ $I_{OUT} = 1.5A$ $V_{OUT} = V_{REF}$			
12	Minimum Load Current 1	I_{OUT1}	I_6 (mA)	4(d)	All	$V_{IN} = - 4.25V$ $V_{OUT} = V_{REF}$ Note 3	0.1	5.0	mA
13	Minimum Load Current 2	I_{OUT2}	I_7 (mA)	4(d)	All	$V_{IN} = - 14.25V$ $V_{OUT} = V_{REF}$ Note 3	0.1	5.0	mA
14	Minimum Load Current 3	I_{OUT3}	I_8 (mA)	4(d)	All	$V_{IN} = - 41.25V$ $V_{OUT} = V_{REF}$ Note 3	1.0	5.0	mA
15	Output Short Circuit Current 1	I_{OS1}	B_1 (A)	4(e)	All	$V_{IN} = - 4.25V$	1.5	3.5	A
16	Output Short Circuit Current 2	I_{OS2}	B_2 (A)	4(e)	All	$V_{IN} = - 40V$	0.2	0.8	A
17	Output Voltage Recovery 1 After Output Short Circuit Current	V_{RECOV1}	E_{10} (V)	4(f)	All	$V_{IN} = - 4.25V$ $I_{OUT} = 0.5A$	- 1.3	- 1.2	V
18	Output Voltage Recovery 2 After Output Short Circuit Current	V_{RECOV2}	E_{11} (V)	4(f)	All	$V_{IN} = - 40V$ $I_{OUT} = 5.0mA$	- 1.3	- 1.2	V

NOTES: See Page 22.



**TABLE 3 - ELECTRICAL MEASUREMENTS AT HIGH AND LOW TEMPERATURES,
+ 125(+ 0 - 5)°C AND - 55(+ 5 - 0)°C (CONT'D)**

Test No.	Characteristics	Symbol	Meas'd Value	Test Fig.	Variant	Test Conditions (Notes 1 and 2)	Limits		Unit
							Min	Max	
19	Start-Up Voltage	V _{START}	E ₁₂ (V)	4(f)	03, 04 and 06	V _{IN} = - 4.25V I _{OUT} = 0.5A	- 1.3	- 1.2	V
					01, 02 and 05	V _{IN} = - 4.25V I _{OUT} = 1.5A			

NOTES: See Page 22.



FIGURE 4(a) - OUTPUT LOAD CURRENT CONDITION

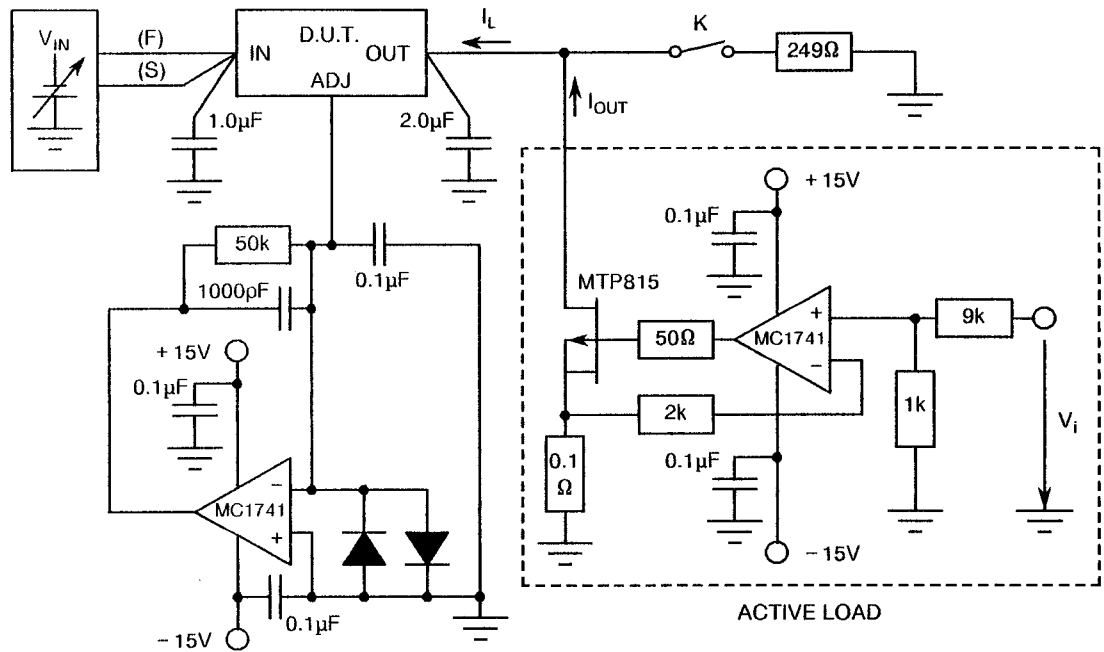

For $I_L > (\text{mA})$: K opened
For $I_L = (\text{mA})$, $V_i = 0$: K closed

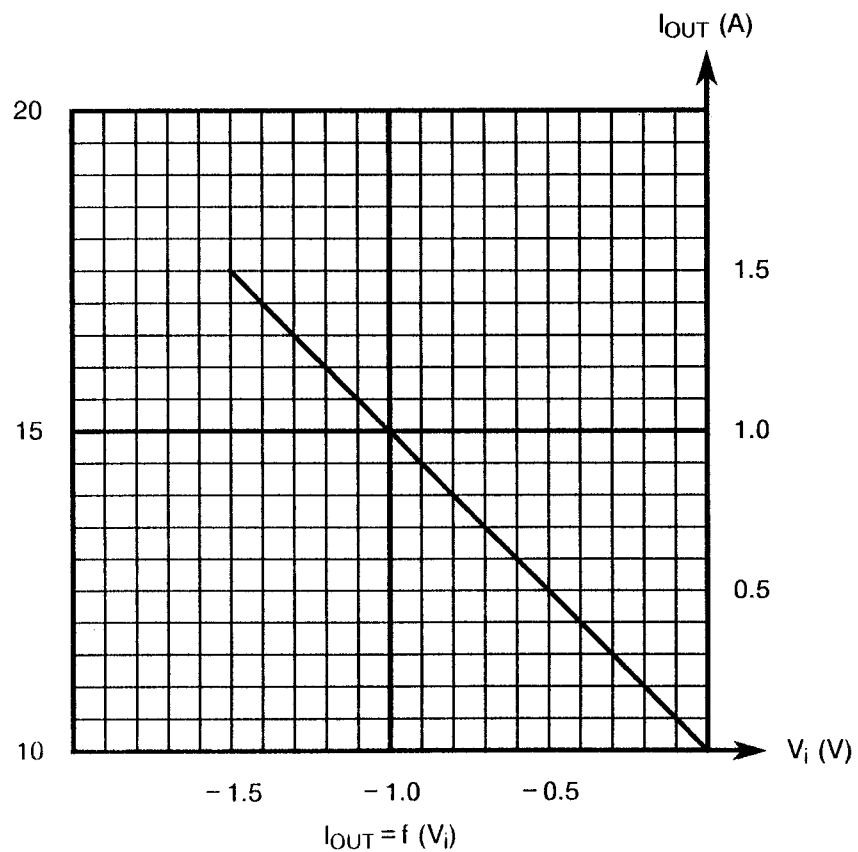
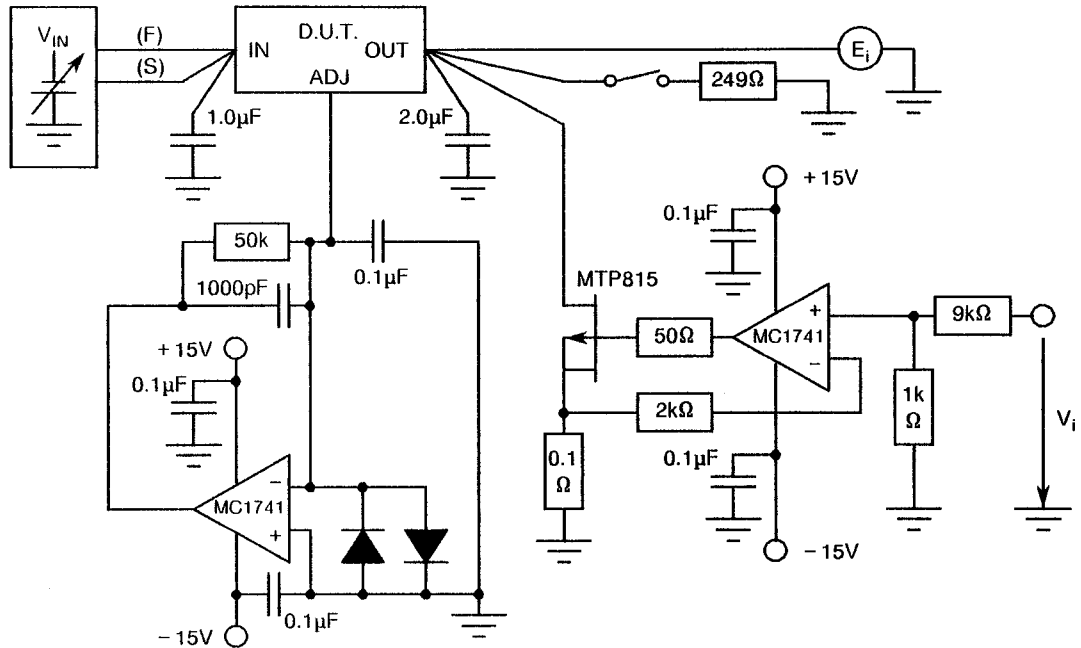



FIGURE 4(b) - REFERENCE VOLTAGE, LINE AND LOAD REGULATION, AND THERMAL REGULATION VOLTAGE



NOTES

1. V_{RLOAD2} = E_7 (V) - E_8 (V) for Variants 03, 04 and 06.
= E_7 (V) - E_9 (V) for Variants 01, 02 and 05.
2. V_{RTH} = E_{14} (V) - E_{13} (V) for Variants 03, 04 and 06.
= E_{16} (V) - E_{15} (V) for Variants 01, 02 and 05.

LINE REGULATION WAVEFORMS

Line reg (mV) = V_{OUT} (mV)

Line reg (%/V) = $\frac{V_{OUT}}{V_{IN}} \times V_{OUT}$

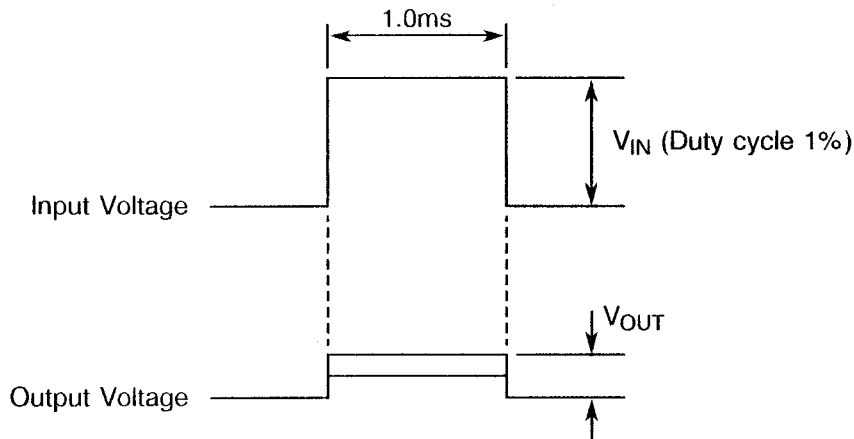



FIGURE 4(b) - REFERENCE VOLTAGE, LINE AND LOAD REGULATION, AND THERMAL REGULATION VOLTAGE (CONTINUED)

LINE REGULATION WAVEFORMS

$$\text{Load reg (mV)} = V_{\text{OUT}} \text{ (mV)}$$

$$\text{Load reg (\%Vo)} = \frac{\Delta V_{\text{OUT}}}{V_{\text{OUT}}}$$

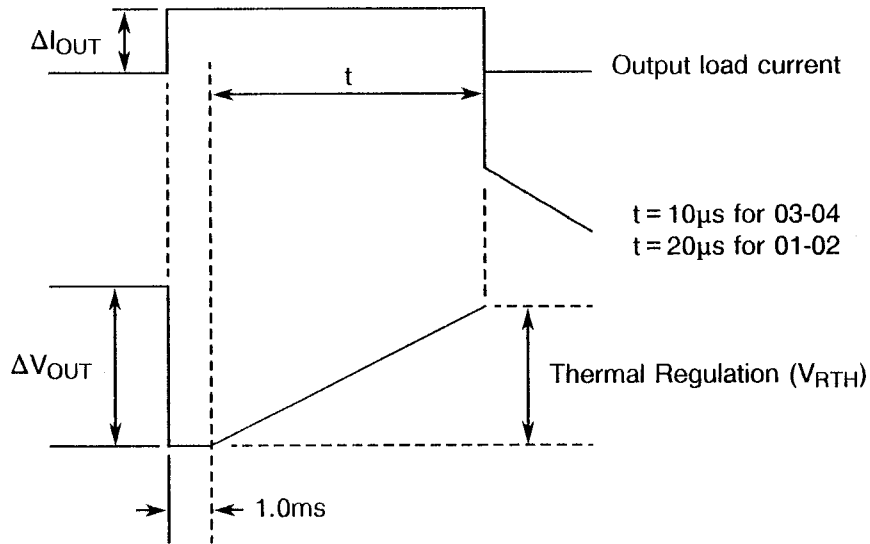
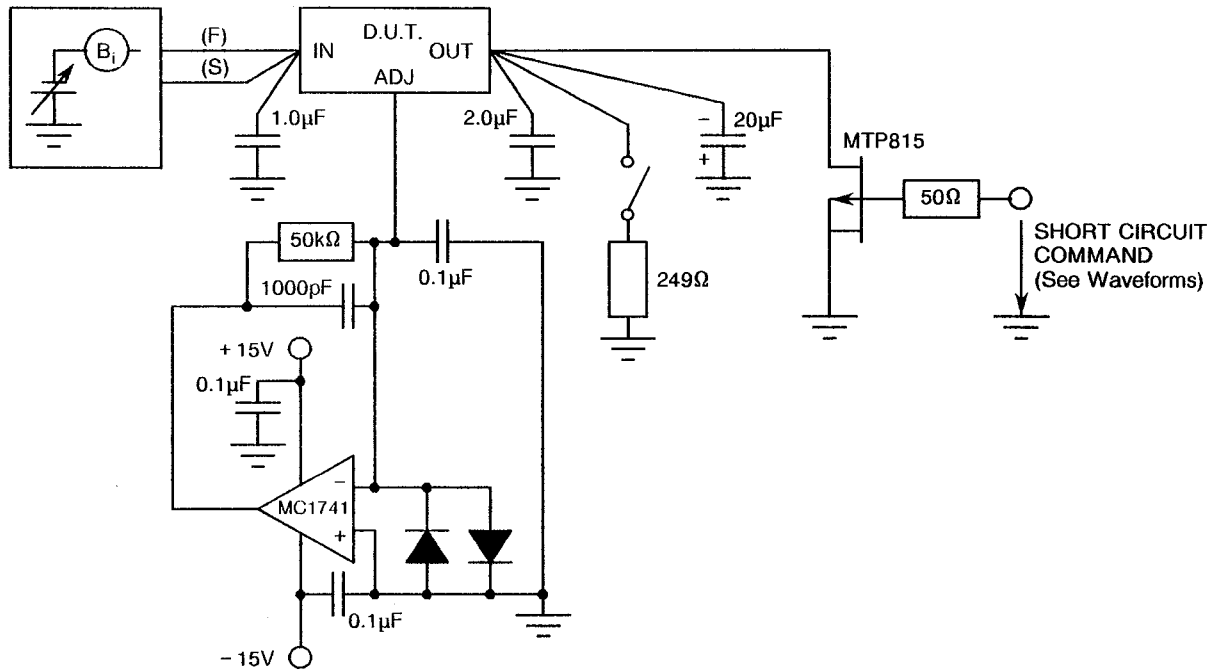



FIGURE 4(e) - OUTPUT SHORT CIRCUIT CURRENT



VOLTAGE WAVEFORMS

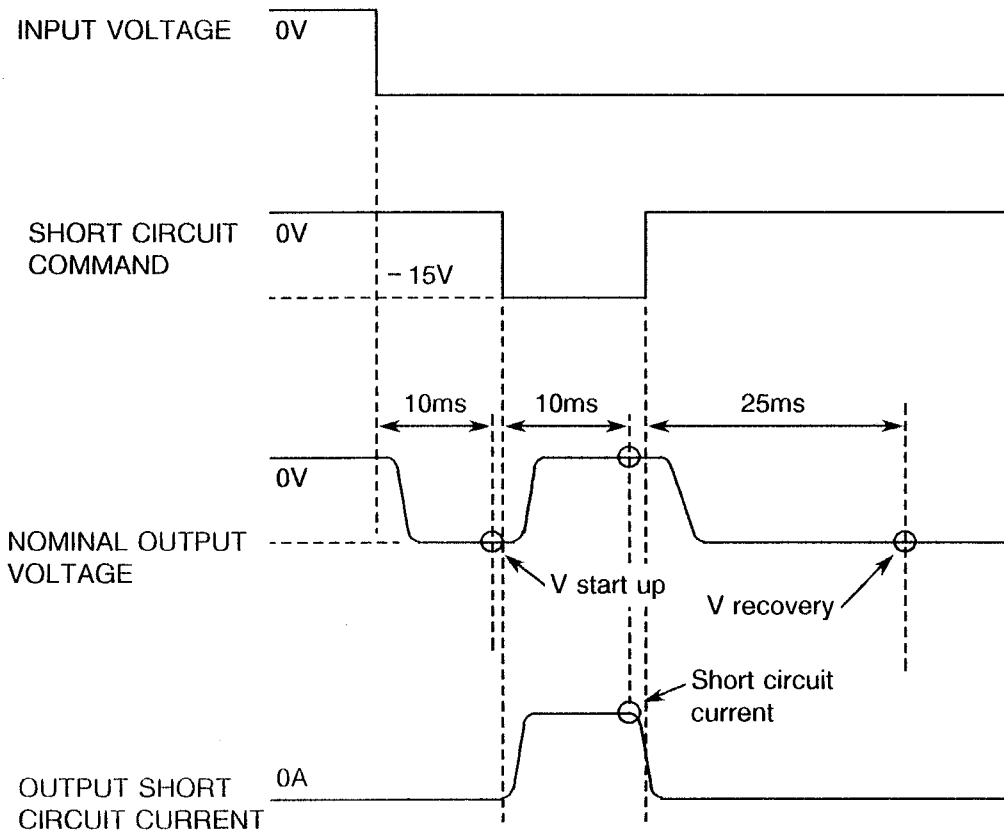
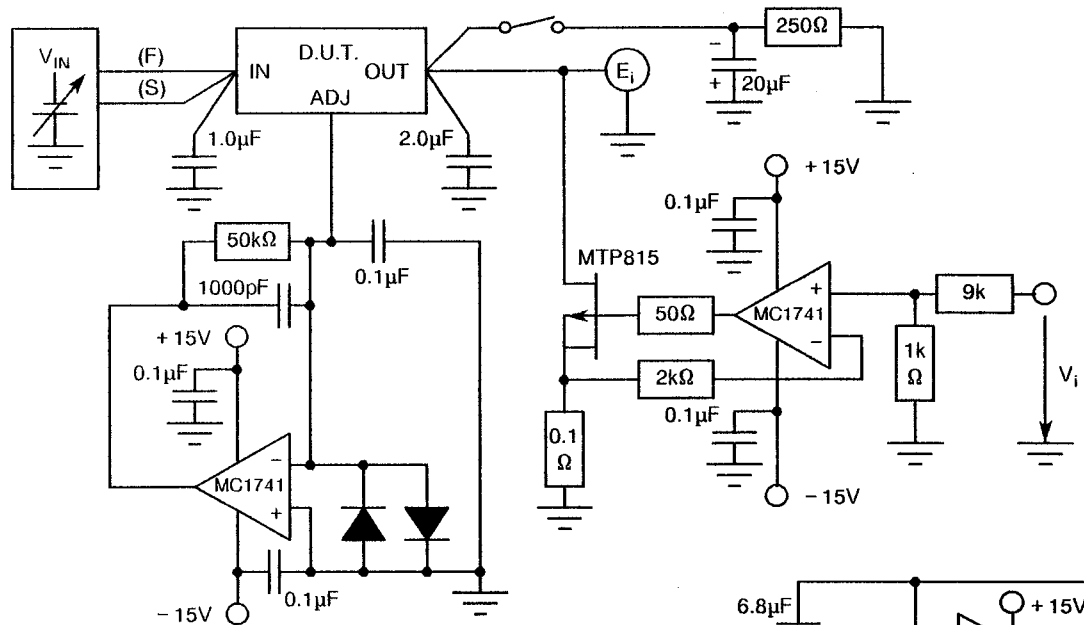



FIGURE 4(f) - OUTPUT VOLTAGE RECOVERY AFTER OUTPUT SHORT CIRCUIT CURRENT AND START-UP VOLTAGE



NOTES

1. For Voltage Waveforms, see Figure 4(e).

FIGURE 4(g) - RIPPLE REJECTION

NOTES

1. $E_{in} = 1.0V_{rms}$.
2. (RMS Value) $RR = 20 \text{ Log } \frac{E_{in}}{E_0} \times 1000$

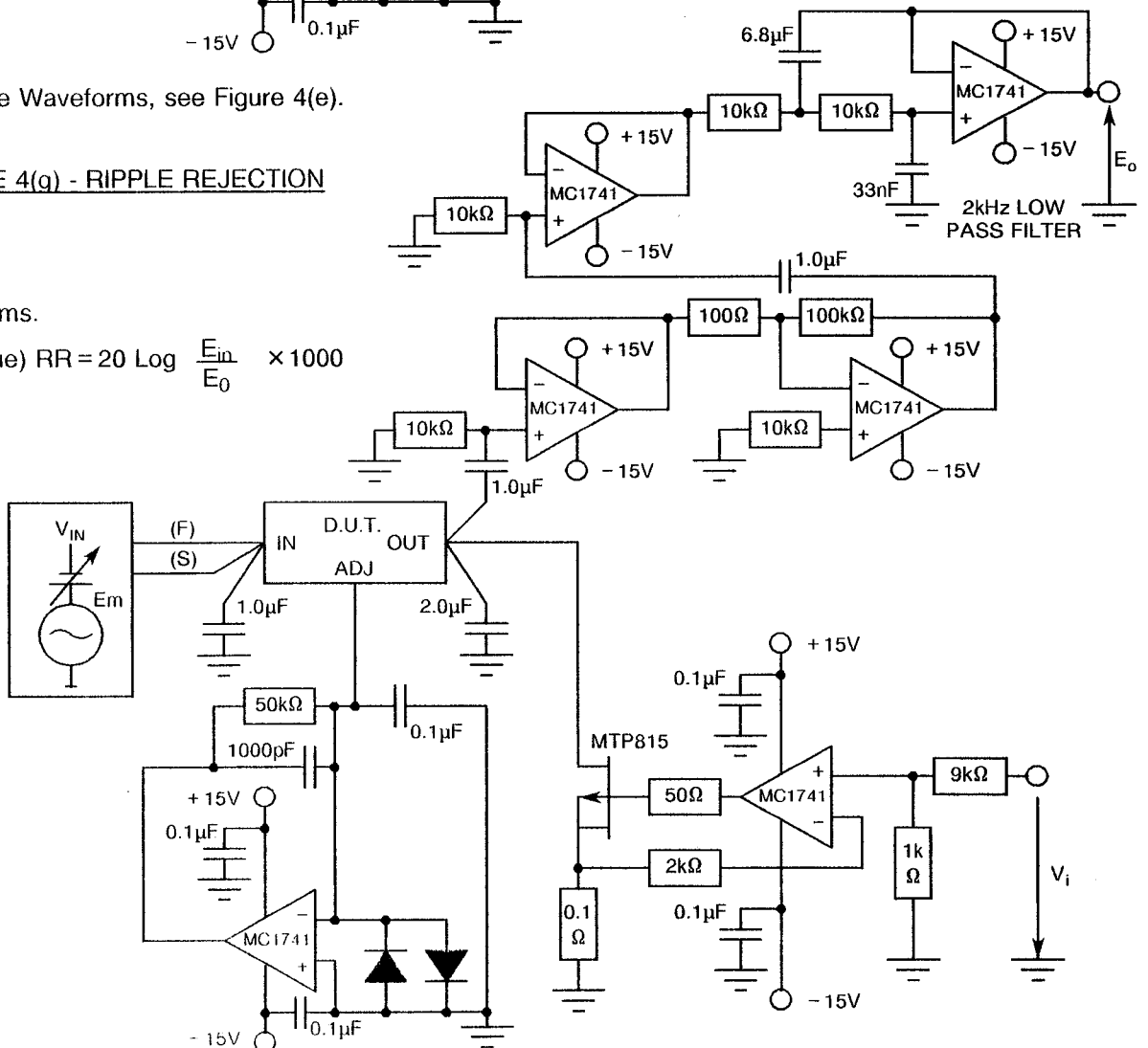
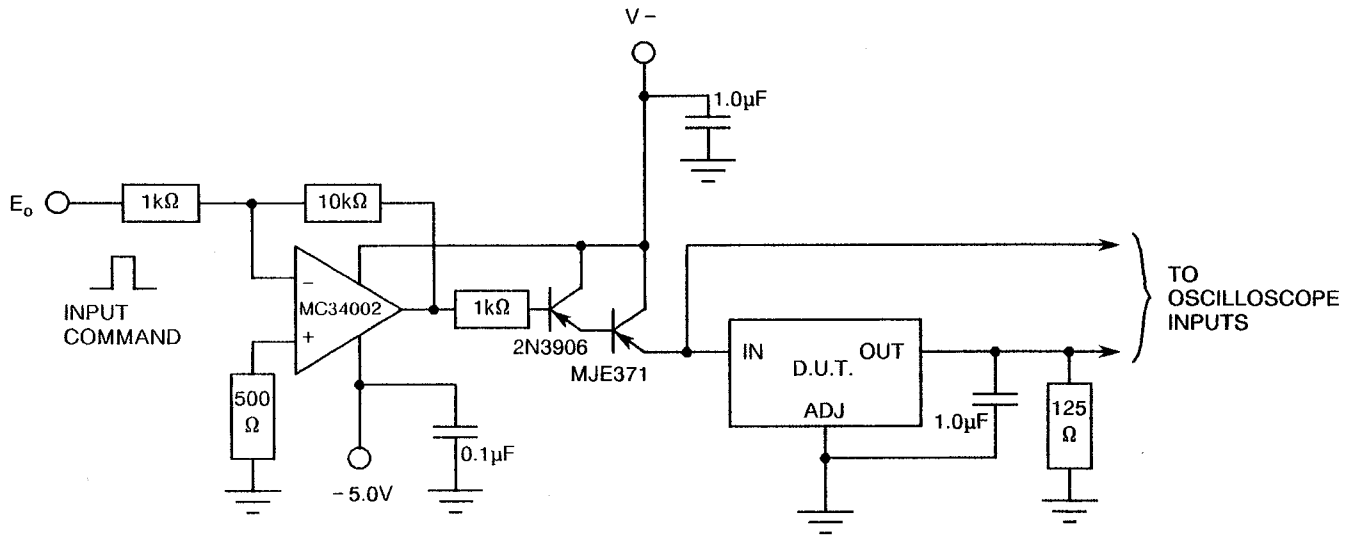
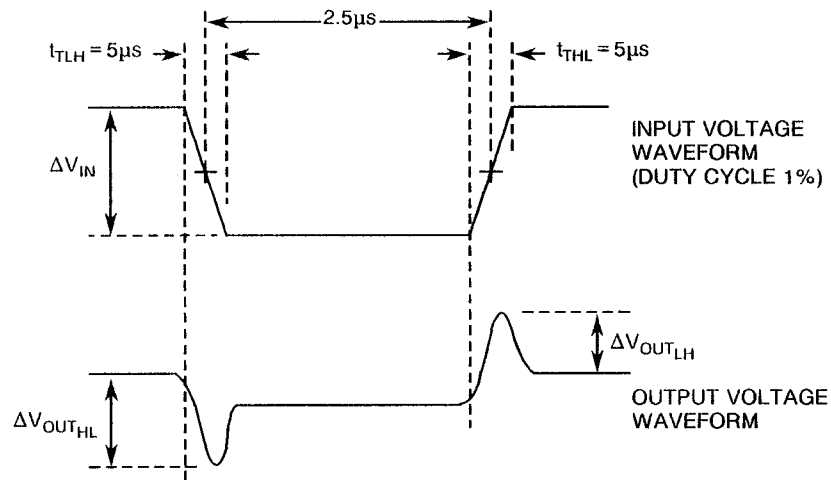



FIGURE 4(h) - LINE TRANSIENT RESPONSE



VOLTAGE WAVEFORMS



NOTES

1. V_{IN} = from -6.25V to -9.25V
2. Line transient response = $\frac{\Delta V_{OUT}}{\Delta V_{IN}}$
3. The input voltage test conditions shall be as defined by the following table:-

Input Voltage (V)	-6.25V	-9.25V
eo (mV)	775	1075



FIGURE 4(j) - LOAD TRANSIENT RESPONSE

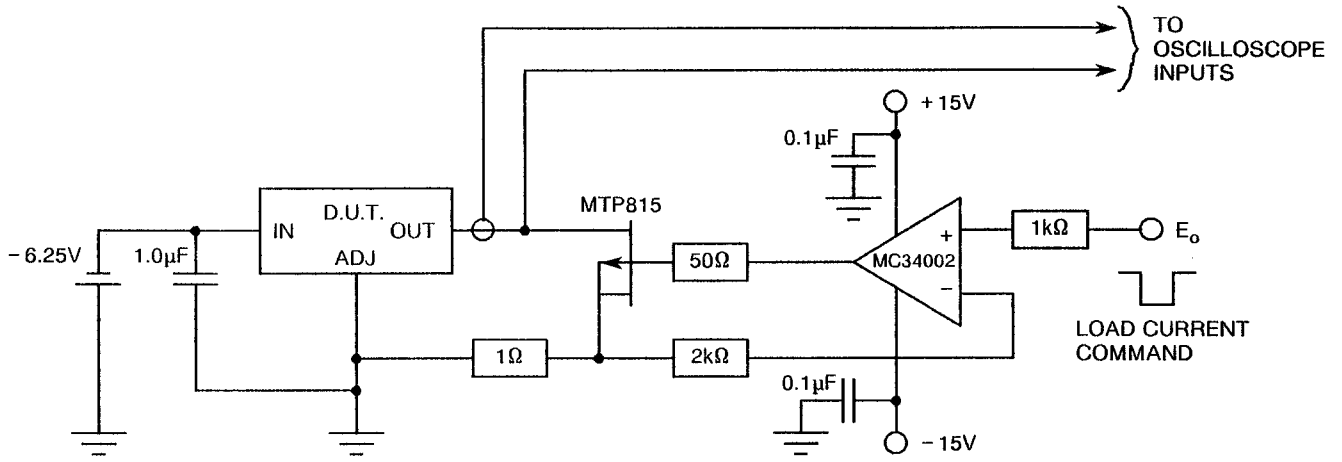

VOLTAGE WAVEFORMS

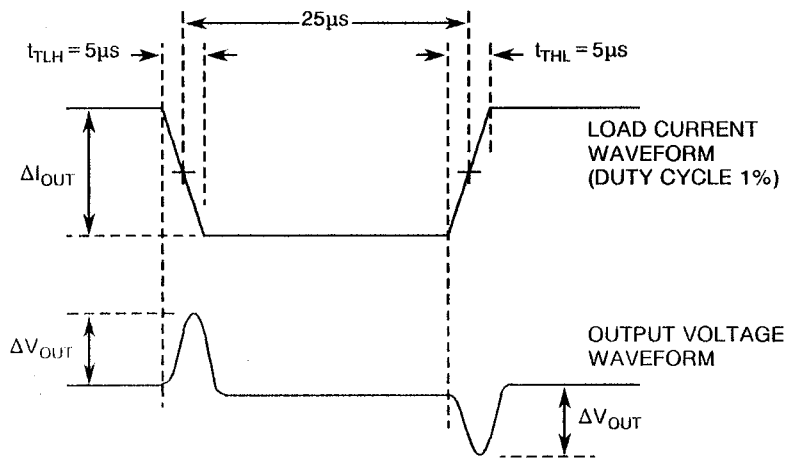

NOTES

1. I_{OUT} : from 50mA to 250mA (Variants 03, 04 and 06)
 I_{OUT} : from 100mA to 500mA (Variants 01, 02 and 05)

2. Load transient response = $\frac{\Delta V_{OUT}}{\Delta I_{OUT}}$ (mV/mA)

3. The load current test conditions shall be as defined by the following table:-

Output Current (mA)	50	100	250	500
e_o (mV)	-50	-100	-250	-500



FIGURE 4(j) - OUTPUT NOISE VOLTAGE

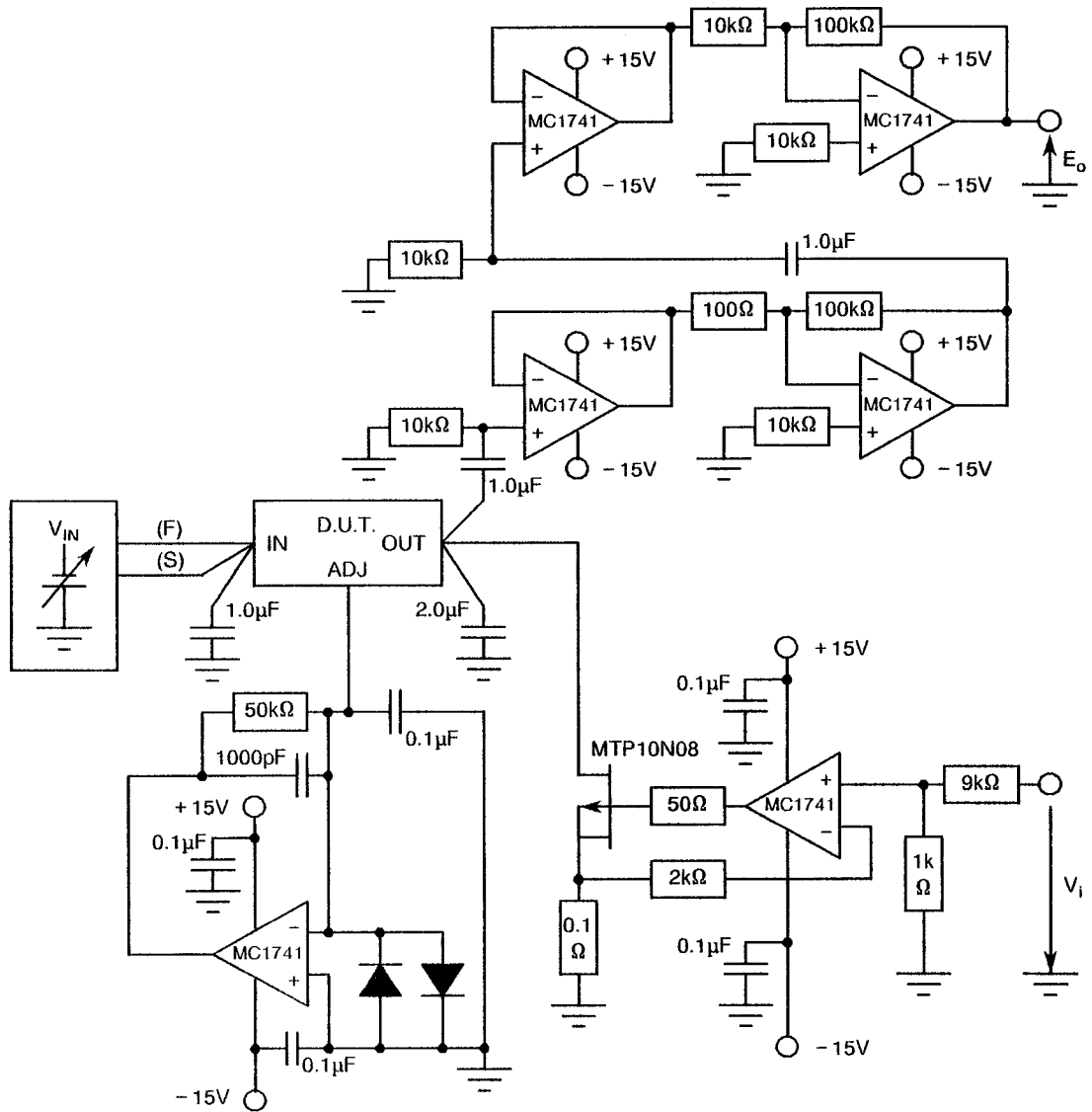

NOTES

1. Bandwidth 10Hz to 10kHz.

2. Noise Voltage = $\frac{E_o}{10000}$ (True RMS value)

**TABLE 4 - PARAMETER DRIFT VALUES**

No.	CHARACTERISTICS	SYMBOL	SPEC. AND/OR TEST METHOD	TEST CONDITIONS	CHANGE LIMITS (Δ)	UNIT
1	Reference Voltage 1	V_{REF1}	As per Table 2	As per Table 2	± 10	mV
2	Reference Voltage 2	V_{REF2}	As per Table 2	As per Table 2	± 10	mV
3	Reference Voltage 3	V_{REF3}	As per Table 2	As per Table 2	± 10	mV
4	Reference Voltage 4	V_{REF4}	As per Table 2	As per Table 2	± 10	mV
5	Line Regulation	V_{RLINE}	As per Table 2	As per Table 2	± 4.0	mV
8	Adjust Pin Current 1	I_{ADJ1}	As per Table 2	As per Table 2	± 10	μA
9	Adjust Pin Current 2	I_{ADJ2}	As per Table 2	As per Table 2	± 10	μA

TABLE 5 - CONDITIONS FOR BURN-IN AND OPERATING LIFE TEST

No.	CHARACTERISTICS	SYMBOL	CONDITION	UNIT
1	Ambient Temperature	T_{amb}	+ 125(+ 0 - 5)	$^{\circ}C$
2	Input Output Voltage Difference	$V_{IN} - V_{OUT}$	40	V
3	Load Resistance Variants 01, 02, 05 Variants 03, 04, 06	R_L	68 220	Ω

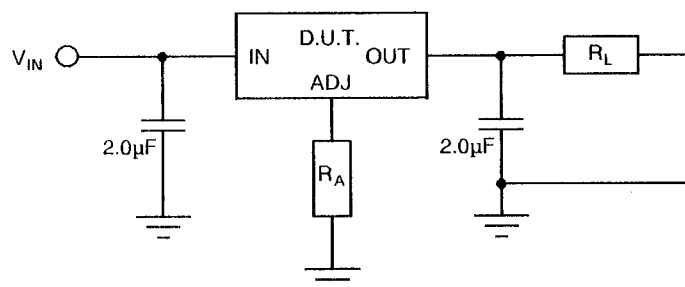
FIGURE 5 - CIRCUIT FOR BURN-IN AND OPERATING LIFE TEST**NOTES**

1. The test is conducted without heatsink.
2. The capacitors may be reduced or eliminated provided the device remains stable.
3. R_A may be either 1.0k Ω or a direct short to ground.



4.8 ENVIRONMENTAL AND ENDURANCE TESTS

4.8.1 Electrical Measurements on Completion of Environmental Tests

The parameters to be measured on completion of environmental tests are scheduled in Table 6. Unless otherwise stated, the measurements shall be performed at $T_{amb} = +22 \pm 3$ °C.

4.8.2 Electrical Measurements at Intermediate Points during Endurance Tests

The parameters to be measured at intermediate points during endurance tests are as scheduled in Table 6 of this specification.

4.8.3 Electrical Measurements on Completion of Endurance Tests

The parameters to be measured on completion of endurance testing are as scheduled in Table 6 of this specification. Unless otherwise stated, the measurements shall be performed at $T_{amb} = +22 \pm 3$ °C.

4.8.4 Conditions for Operating Life Tests

The requirements for operating life testing are specified in Section 9 of ESA/SCC Generic Specification No. 9000. The conditions for operating life testing shall be as specified in Table 5 of this specification.

4.8.5 Electrical Circuits for Operating Life Tests

Circuits for use in performing the operating life tests are shown in Figure 5.

4.8.6 Conditions for High Temperature Storage Test

The requirements for the high temperature storage test are specified in ESA/SCC Generic Specification No. 9000. The conditions for high temperature storage shall be $T_{amb} = +150(+0 - 5)$ °C.

**TABLE 6 - ELECTRICAL MEASUREMENTS ON COMPLETION OF ENVIRONMENTAL TESTS AND AT INTERMEDIATE POINTS AND ON COMPLETION OF ENDURANCE TESTING**

No.	CHARACTERISTICS	SYMBOL	SPEC. AND/OR TEST METHOD	TEST CONDITIONS	LIMITS		UNIT
					MIN	MAX	
1	Reference Voltage 1	V_{REF1}	As per Table 2	As per Table 2	-1.275	-1.225	V
2	Reference Voltage 2	V_{REF2}	As per Table 2	As per Table 2	-1.275	-1.225	V
3	Reference Voltage 3	V_{REF3}	As per Table 2	As per Table 2	-1.275	-1.225	V
4	Reference Voltage 4	V_{REF4}	As per Table 2	As per Table 2	-1.275	-1.225	V
5	Line Regulation	V_{RLINE}	As per Table 2	As per Table 2	-9.0	9.0	mV
8	Adjust Pin Current 1	I_{ADJ1}	As per Table 2	As per Table 2	25	100	μA
9	Adjust Pin Current 2	I_{ADJ2}	As per Table 2	As per Table 2	25	100	μA



ESC

ESA/SCC Detail Specification
No. 9102/007

PAGE 38

ISSUE 1

APPENDIX 'A'

Page 1 of 1

AGREED DEVIATIONS FOR MOTOROLA (F)

ITEMS AFFECTED	DESCRIPTION OF DEVIATIONS
Table 2 (a.c.)	Test No. 21, Ripple Rejection - The test may be performed at $f = 1000\text{Hz}$.