



**europaean space agency  
agence spatiale européenne**



Pages 1 to 55

**INTEGRATED CIRCUITS, SILICON MONOLITHIC,  
CMOS MICROPOWER PHASE-LOCKED LOOP,  
BASED ON TYPE 4046B**

**ESA/SCC Detail Specification No. 9202/044**



**space components  
coordination group**

Issue/Rev.	Date	Approved by	
		SCCG Chairman	ESA Director General or his Deputy
Issue 3	June 2001		

**DOCUMENTATION CHANGE NOTICE**

Rev. Letter	Rev. Date	Reference	CHANGE Item	Approved DCR No.
		This Issue supersedes Issue 2 and incorporates all modifications defined in Revisions 'A', 'B' and 'C' to Issue 2 and the changes agreed in the following DCRs:-		
		Cover page		None
		DCN		None
		Para. 1.3	: New sentence added	221602
		Table 1(b)	: No. 8, Maximum temperature amended	221602
		Figure 2(a)	: Dimension 'C' min corrected to "1.49"	23933
		Figure 2(e)	: Dimension 'E' corrected	23933
		Para. 4.8.6	: Last sentence deleted, new text added	221602
		Appendix 'A'	: Appendix added	221602

**TABLE OF CONTENTS**

	<u>Page</u>
<b>1. <u>GENERAL</u></b>	<b>5</b>
1.1 Scope	5
1.2 Component Type Variants	5
1.3 Maximum Ratings	5
1.4 Parameter Derating Information	5
1.5 Physical Dimensions	5
1.6 Pin Assignment	5
1.7 Truth Table	5
1.8 Circuit Schematic	5
1.9 Functional Diagram	5
1.10 Handling Precautions	5
1.11 Input Protection Network	5
<b>2. <u>APPLICABLE DOCUMENTS</u></b>	<b>16</b>
<b>3. <u>TERMS, DEFINITIONS, ABBREVIATIONS, SYMBOLS AND UNITS</u></b>	<b>16</b>
<b>4. <u>REQUIREMENTS</u></b>	<b>16</b>
4.1 General	16
4.2 Deviations from Generic Specification	16
4.2.1 Deviations from Special In-process Controls	16
4.2.2 Deviations from Final Production Tests	16
4.2.3 Deviations from Burn-in Tests	16
4.2.4 Deviations from Qualification Tests	16
4.2.5 Deviations from Lot Acceptance Tests	17
4.3 Mechanical Requirements	17
4.3.1 Dimension Check	17
4.3.2 Weight	17
4.4 Materials and Finishes	17
4.4.1 Case	17
4.4.2 Lead Material and Finish	17
4.5 Marking	17
4.5.1 General	17
4.5.2 Lead Identification	17
4.5.3 The SCC Component Number	18
4.5.4 Traceability Information	18
4.6 Electrical Measurements	18
4.6.1 Electrical Measurements at Room Temperature	18
4.6.2 Electrical Measurements at High and Low Temperatures	18
4.6.3 Circuits for Electrical Measurements	18
4.7 Burn-in Tests	18
4.7.1 Parameter Drift Values	18
4.7.2 Conditions for H.T.R.B. and Burn-in	18
4.7.3 Electrical Circuits for H.T.R.B. and Burn-in	18
4.8 Environmental and Endurance Tests	52
4.8.1 Electrical Measurements on Completion of Environmental Tests	52
4.8.2 Electrical Measurements at Intermediate Points during Endurance Tests	52
4.8.3 Electrical Measurements on Completion of Endurance Tests	52
4.8.4 Conditions for Operating Life Test	52
4.8.5 Electrical Circuits for Operating Life Tests	52
4.8.6 Conditions for High Temperature Storage Test	52

**TABLES**

	<u>Page</u>
1(a) Type Variants	6
1(b) Maximum Ratings	6
2 Electrical Measurements at Room Temperature, d.c. Parameters	19
Electrical Measurements at Room Temperature, a.c. Parameters	24
3(a) Electrical Measurements at High Temperature	27
3(b) Electrical Measurements at Low Temperature	31
4 Parameter Drift Values	47
5(a) Conditions for Burn-in High Temperature Reverse Bias, N-Channels	48
5(b) Conditions for Burn-in High Temperature Reverse Bias, P-Channels	48
5(c) Conditions for Burn-in Dynamic	49
6 Electrical Measurements on Completion of Environmental Tests and at Intermediate Points and on Completion of Endurance Testing	53

**FIGURES**

1 Not applicable	
2 Physical Dimensions	7
3(a) Pin Assignment	13
3(b) Truth Table	N/A
3(c) Circuit Schematic	N/A
3(d) Functional Diagram	14
3(e) Input Protection Network	15
4 Circuits for Electrical Measurements	35
5(a) Electrical Circuit for Burn-in High Temperature Reverse Bias, N-Channels	50
5(b) Electrical Circuit for Burn-in High Temperature Reverse Bias, P-Channels	50
5(c) Electrical Circuit for Burn-in Dynamic	51

**APPENDICES (Applicable to specific Manufacturers only)**

'A' Agreed Deviations for STMicroelectronics (F)	55
--	----

**1. GENERAL****1.1 SCOPE**

This specification details the ratings, physical and electrical characteristics, test and inspection data for a silicon monolithic, CMOS Micropower Phase-Locked Loop, having fully buffered outputs, based on Type 4046B. It shall be read in conjunction with ESA/SCC Generic Specification No. 9000, the requirements of which are supplemented herein.

**1.2 COMPONENT TYPE VARIANTS**

Variants of the basic type integrated circuits specified herein, which are also covered by this specification, are given in Table 1(a).

**1.3 MAXIMUM RATINGS**

The maximum ratings, which shall not be exceeded at any time during use or storage, applicable to the integrated circuits specified herein, are as scheduled in Table 1(b).

Maximum ratings shall only be exceeded during testing to the extent specified in this specification and when stipulated in Test Methods and Procedures of the applicable ESA/SCC Generic Specification.

**1.4 PARAMETER DERATING INFORMATION (FIGURE 1)**

Not applicable.

**1.5 PHYSICAL DIMENSIONS**

The physical dimensions of the integrated circuits specified herein are as shown in Figure 2.

**1.6 PIN ASSIGNMENT**

As per Figure 3(a).

**1.7 TRUTH TABLE**

As per Figure 3(b).

**1.8 CIRCUIT SCHEMATIC**

As per Figure 3(c).

**1.9 FUNCTIONAL DIAGRAM**

As per Figure 3(d).

**1.10 HANDLING PRECAUTIONS**

These devices are susceptible to damage by electrostatic discharge. Therefore, suitable precautions shall be employed for protection during all phases of manufacture, testing, packaging, shipment and any handling. These components are Categorised as Class 1 with a Minimum Critical Path Failure Voltage of 400 Volts

**1.11 INPUT PROTECTION NETWORK**

Double diode protection shall be incorporated into each input as shown in Figure 3(e).

**TABLE 1(a) - TYPE VARIANTS**

VARIANT	CASE	FIGURE	LEAD MATERIAL AND/OR FINISH
01	FLAT	2(a)	G2 or G8
02	FLAT	2(a)	G4
03	D.I.L.	2(b)	G2 or G8
04	D.I.L.	2(b)	G4
07	CHIP CARRIER	2(c)	2
08	D.I.L.	2(d)	G2
09	D.I.L.	2(d)	G4
10	SO CERAMIC	2(e)	G2
11	SO CERAMIC	2(e)	G4

**TABLE 1(b) - MAXIMUM RATINGS**

No.	CHARACTERISTICS	SYMBOL	MAXIMUM RATINGS	UNIT	REMARKS
1	Supply Voltage	$V_{DD}$	-0.5 to +18	V	Note 1
2	Input Voltage	$V_{IN}$	-0.5 to $V_{DD} + 0.5$	V	Note 2 Power on
3	D.C. Input Current	$\pm I_{IN}$	10	mA	-
4	D.C. Output Current	$\pm I_O$	10	mA	Note 3
5	Device Dissipation	$P_D$	200	mWdc	Per Package
6	Output Dissipation	$P_{DSO}$	100	mWdc	Note 4
7	Operating Temperature Range	$T_{op}$	-55 to +125	°C	-
8	Storage Temperature Range	$T_{stg}$	-65 to +150	°C	-
9	Soldering Temperature For FP and DIP For CCP	$T_{sol}$	+300 +245	°C	Note 5 Note 6

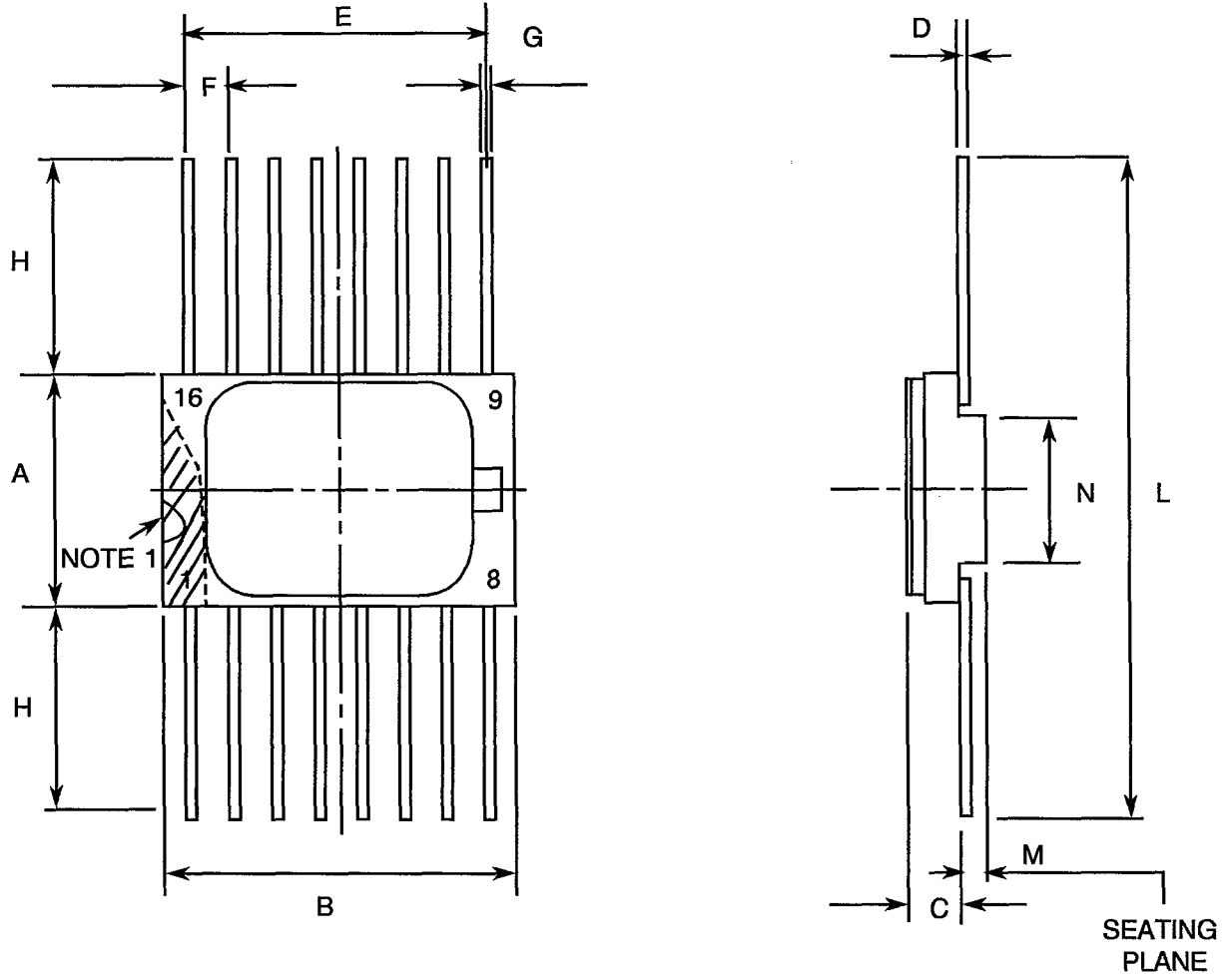
**NOTES**

- Device is functional from +3V to +15V with reference to  $V_{SS}$ .
- $V_{DD} + 0.5V$  should not exceed +18V.
- The maximum output current of any single output.
- The maximum power dissipation of any single output.
- Duration 10 seconds maximum at a distance of not less than 1.5mm from the device body and the same lead shall not be resoldered until 3 minutes have elapsed.
- Duration 30 seconds maximum and the same terminal shall not be resoldered until 3 minutes have elapsed.



**FIGURE 2 - PHYSICAL DIMENSIONS**

**FIGURE 2(a) - FLAT PACKAGE, 16-PIN**



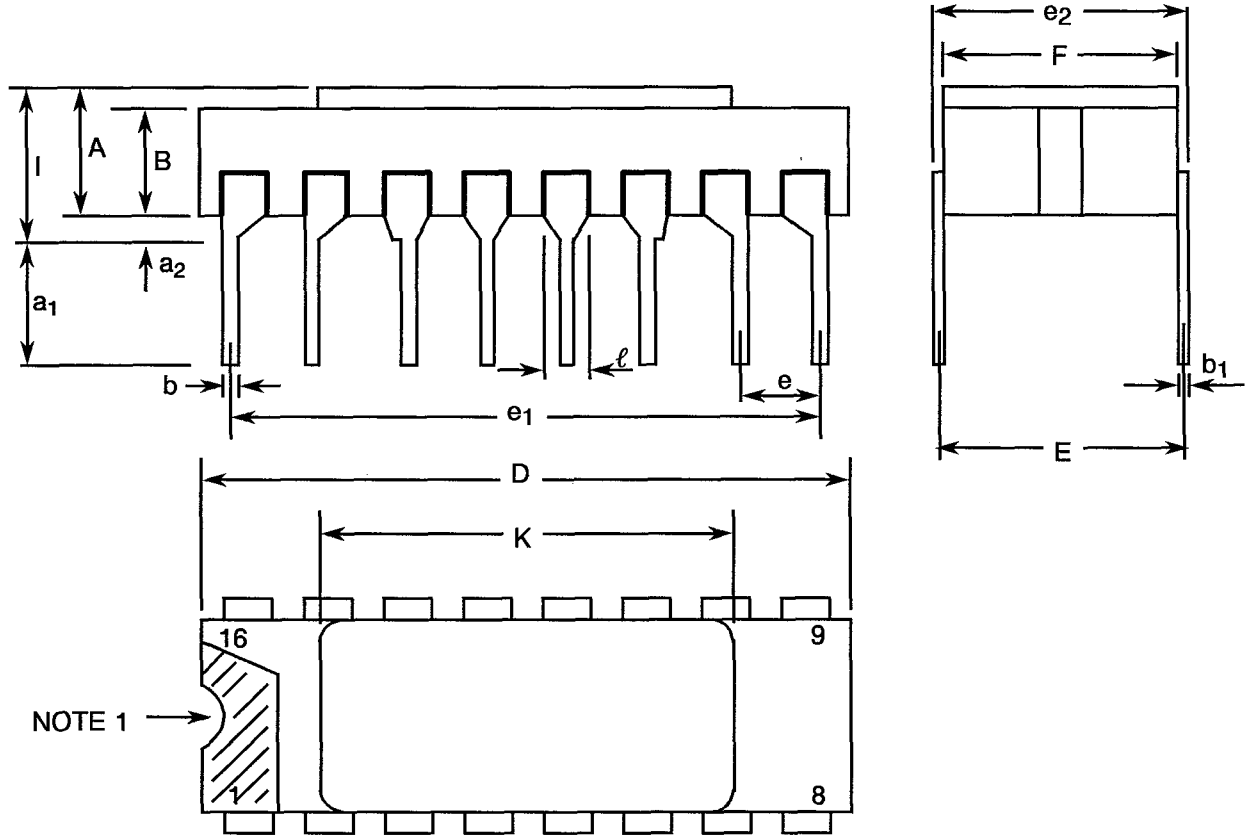
SYMBOL	MILLIMETRES		NOTES
	MIN	MAX	
A	6.75	7.06	
B	9.76	10.14	
C	1.49	1.95	
D	0.102	0.152	3
E	8.76	9.01	
F	1.27	TYPICAL	4
G	0.38	0.48	3
H	6.0	-	3
L	18.75	22.0	
M	0.33	0.43	
N	4.31	TYPICAL	

**NOTES:** See Page 12.



**FIGURE 2 - PHYSICAL DIMENSIONS (CONTINUED)**

**FIGURE 2(b) - DUAL-IN-LINE PACKAGE, 16-PIN**



NOTE 1 →

SYMBOL	MILLIMETRES		NOTES
	MIN	MAX	
A	2.10	2.54	
a <sub>1</sub>	3.0	3.7	
a <sub>2</sub>	0.63	1.14	2
B	1.82	2.23	
b	0.40	0.50	3
b <sub>1</sub>	0.20	0.30	3
D	18.79	19.20	
E	7.36	7.87	
e	2.41	2.67	4
e <sub>1</sub>	17.65	17.90	
e <sub>2</sub>	7.62	8.12	
F	7.11	7.62	
I	-	3.70	
K	10.90	12.10	
ℓ	1.27 TYPICAL		

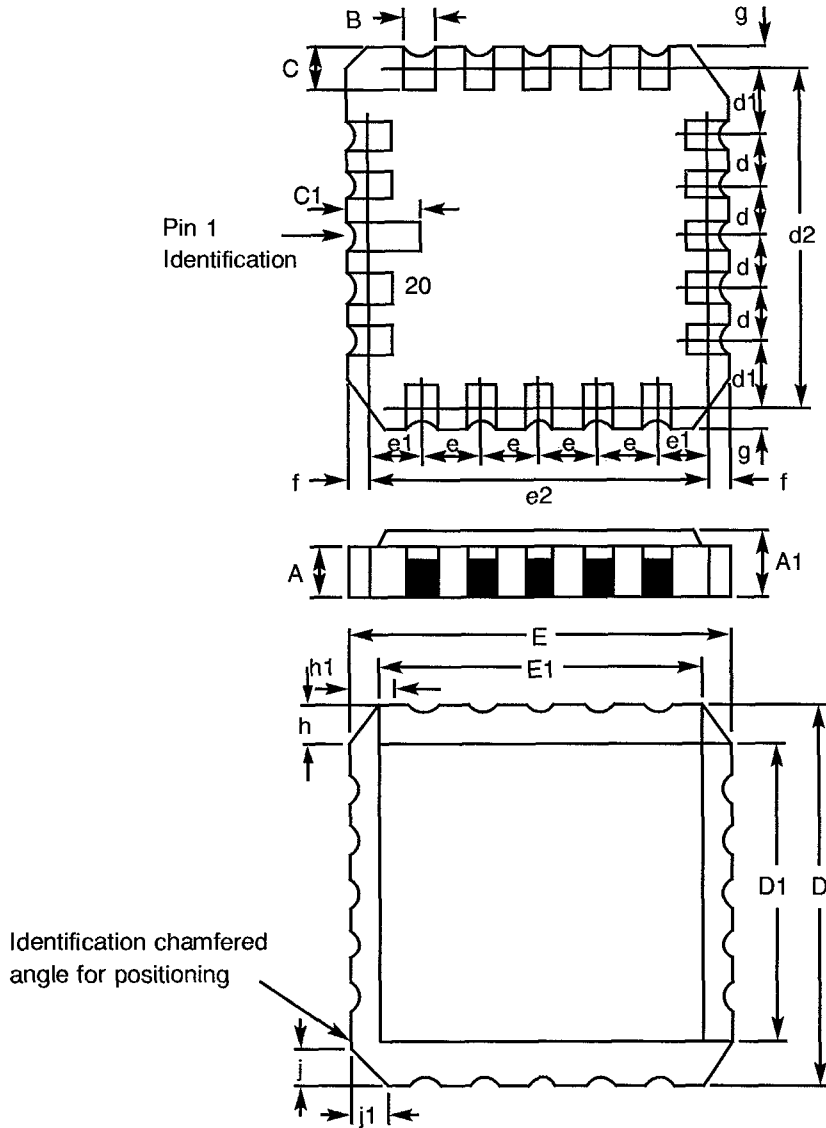
**NOTES:** See Page 12.





**FIGURE 2 - PHYSICAL DIMENSIONS (CONTINUED)**

**FIGURE 2(c) - CHIP CARRIER - 20-TERMINAL**



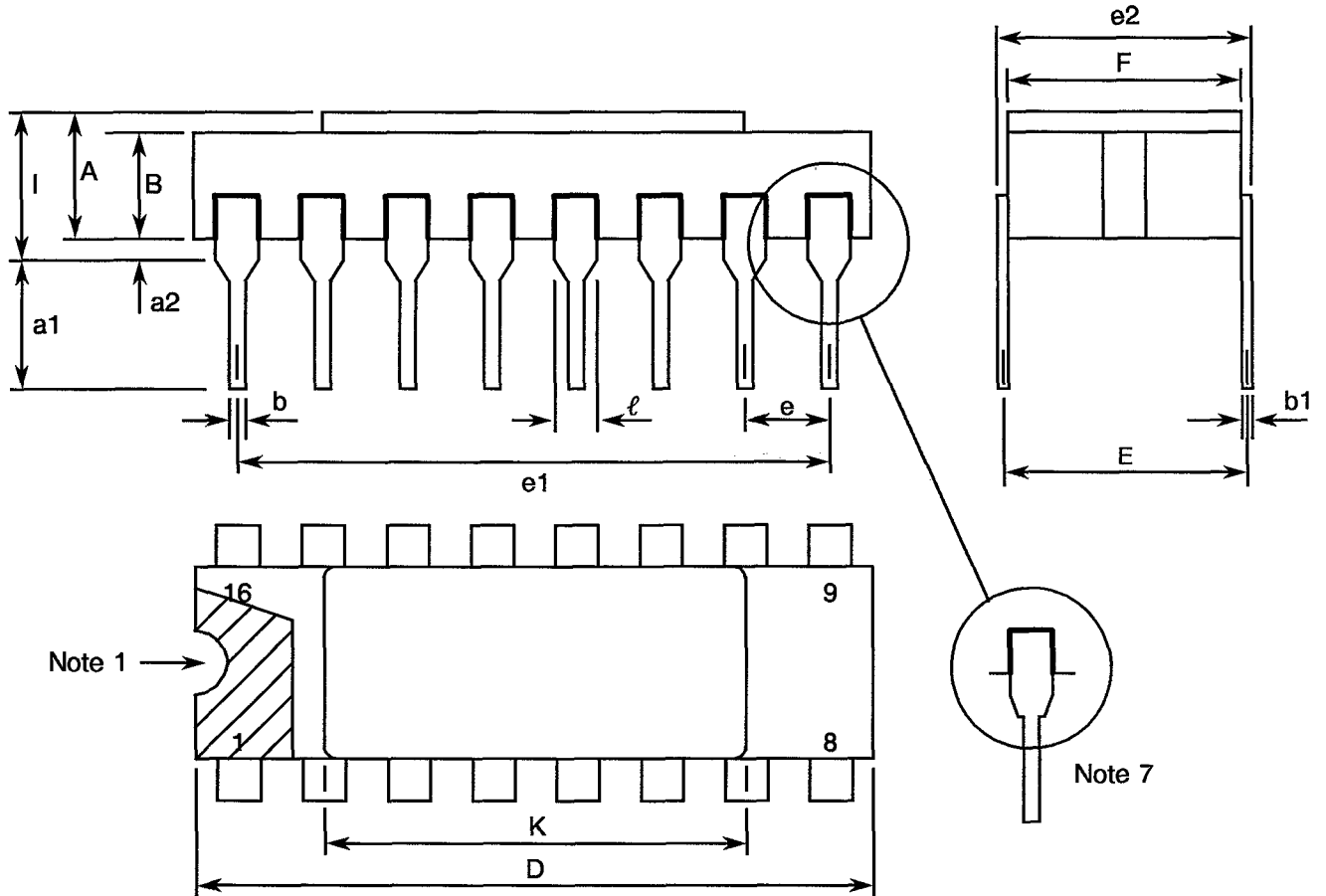
DIMENSIONS	MILLIMETRES		NOTES
	MIN	MAX	
A	1.14	1.95	
A1	1.63	2.36	
B	0.55	0.72	3
C	1.06	1.47	3
C <sub>1</sub>	1.91	2.41	
D	8.67	9.09	
D1	7.21	7.52	
d, d1	1.27	TYPICAL	4
d2	7.62	TYPICAL	
E	8.67	9.09	
E1	7.21	7.52	
e, e1	1.27	TYPICAL	4
e2	7.62	TYPICAL	
f, g	-	0.76	
h, h1	1.01	TYPICAL	6
j, j1	0.51	TYPICAL	5

**NOTES:** See Page 12.



**FIGURE 2 - PHYSICAL DIMENSIONS (CONTINUED)**

**FIGURE 2(d) - DUAL-IN-LINE PACKAGE, 16-PIN**



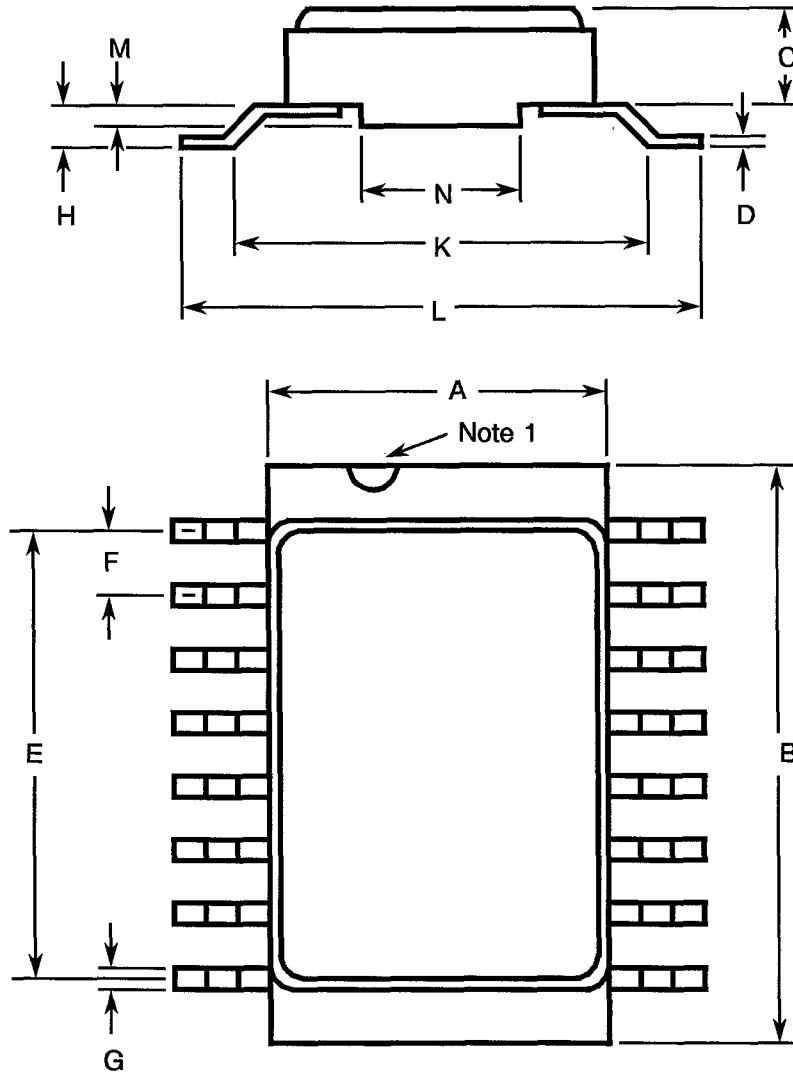
SYMBOL	MILLIMETRES		NOTES
	MIN	MAX	
A	2.10	2.71	
a1	3.00	3.70	
a2	0.63	1.14	2
B	1.82	2.39	
b	0.40	0.50	3
b1	0.20	0.30	3
D	20.06	20.58	
E	7.36	7.87	
e	2.54 TYPICAL		4
e1	17.65	17.90	
e2	7.62	8.12	
F	7.29	7.70	
I	-	3.83	
K	10.90	12.10	
l	1.14	1.50	

**NOTES:** See Page 12.



**FIGURE 2 - PHYSICAL DIMENSIONS (CONTINUED)**

**FIGURE 2(e) - SMALL OUTLINE CERAMIC PACKAGE, 16-PIN**



SYMBOL	MILLIMETRES		NOTES
	MIN.	MAX.	
A	6.75	7.06	
B	9.76	10.14	
C	1.49	1.95	
D	0.102	0.152	3
E	8.76	9.01	
F	1.27 TYPICAL		4
G	0.38	0.48	3
H	0.60	0.90	3
K	9.00 TYPICAL		
L	10	10.65	
M	0.33	0.43	
N	4.31 TYPICAL		

**NOTES:** See Page 12.



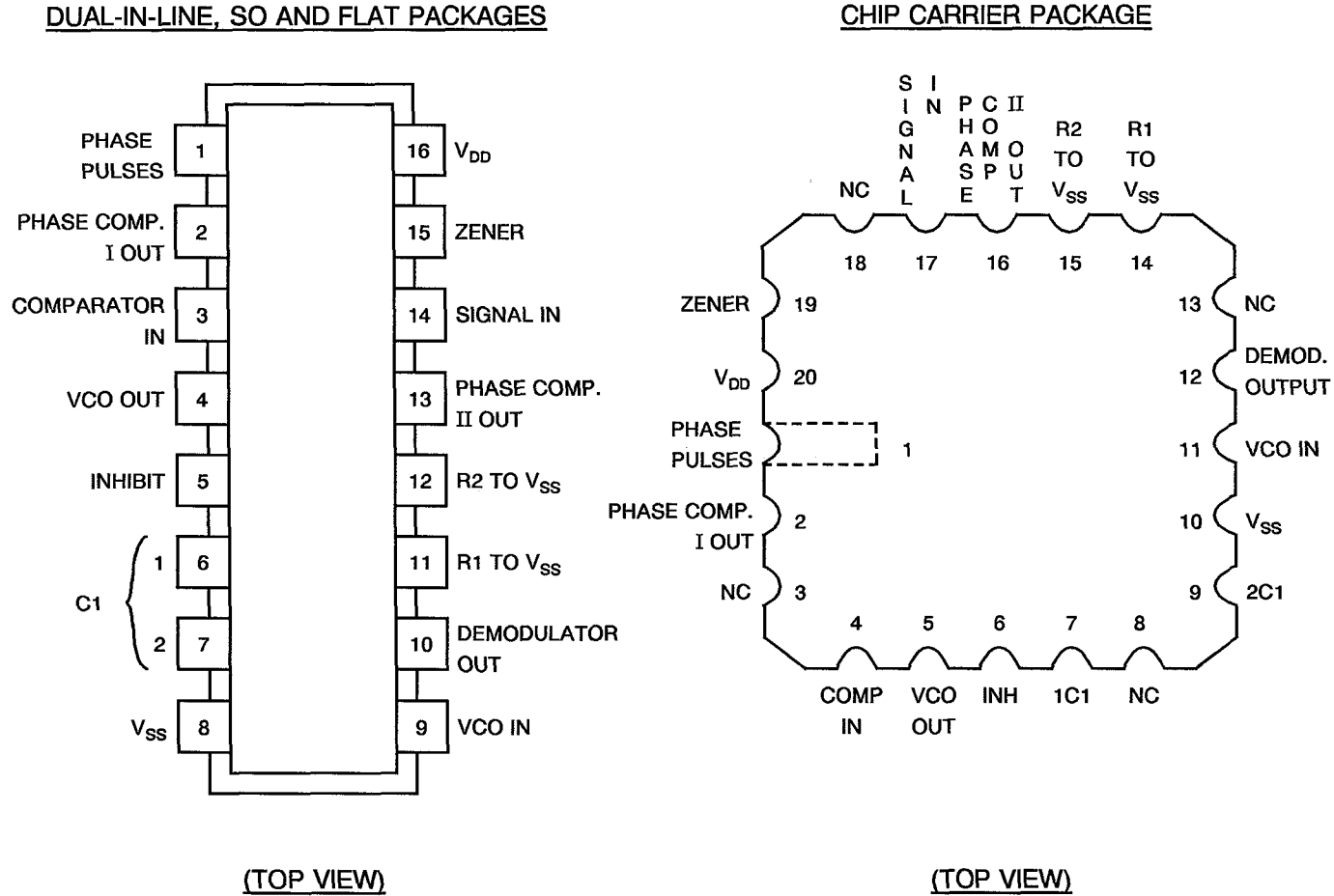
**FIGURE 2 - PHYSICAL DIMENSIONS (CONTINUED)**

**NOTES TO FIGURES 2(a) TO 2(e) INCLUSIVE**

1. Index area; a notch, letter or dot shall be located adjacent to Pin 1 and shall be within the shaded area shown. For chip carrier packages the index shall be as defined in Figure 2(c).
2. The dimension shall be measured from the seating plane to the base plane.
3. All leads or terminals.
4. 16 pin packages : 14 spaces  
20 terminal packages : 12 spaces
5. Index corner only.
6. Three non-index corners.
7. For all pins, either pin shape may be supplied.



**FIGURE 3(a) - PIN ASSIGNMENT**



FLAT PACKAGE, SO AND DUAL-IN-LINE TO CHIP CARRIER PIN ASSIGNMENT

FLAT PACKAGE AND DUAL-IN-LINE PIN OUTS	1	2	3	4	5	6	7	8	9	10	11	12	13	14	15	16
CHIP CARRIER PIN OUTS	1	2	4	5	6	7	9	10	11	12	14	15	16	17	19	20



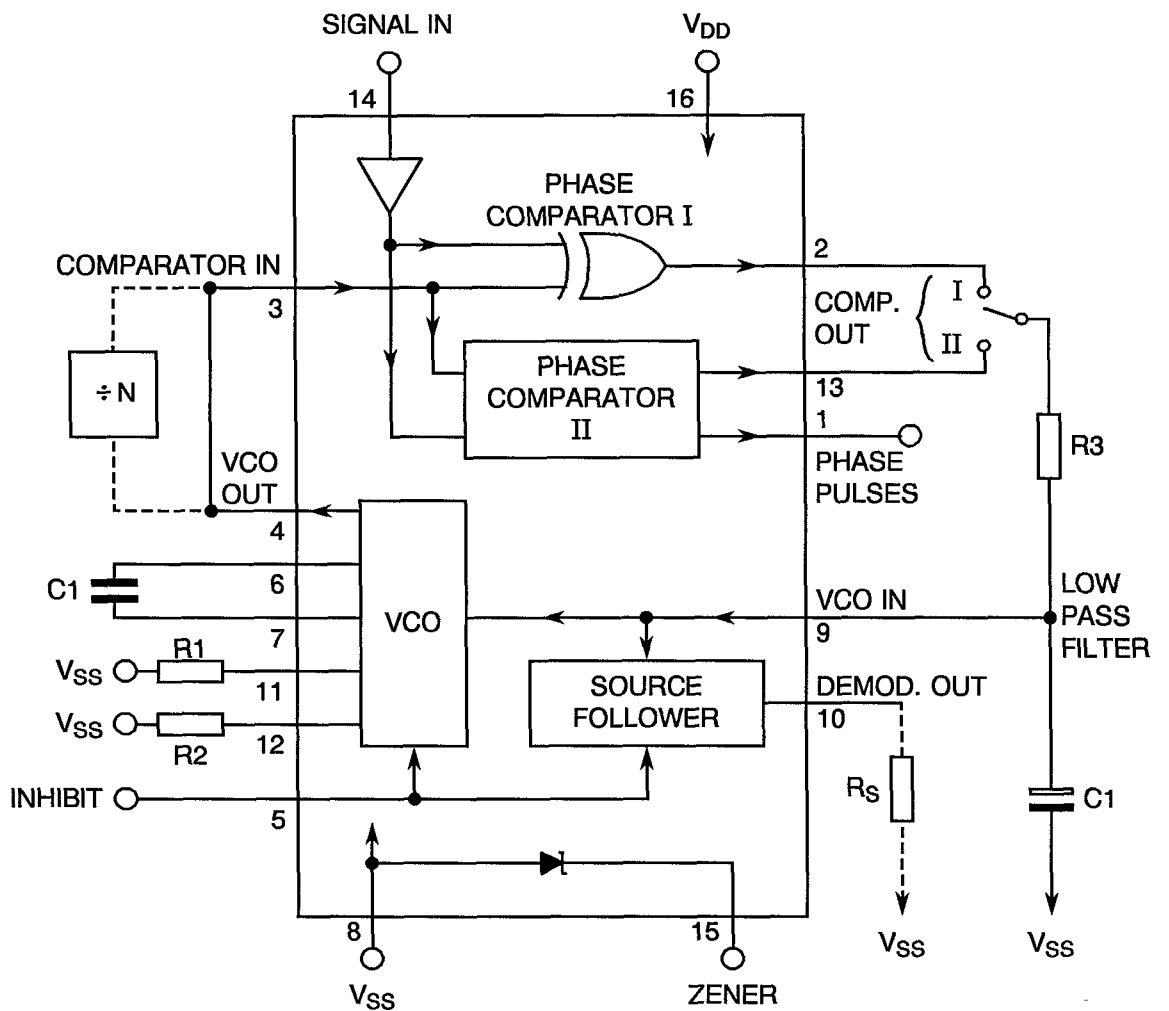
**FIGURE 3(b) - TRUTH TABLE**

Not applicable.

**FIGURE 3(c) - CIRCUIT SCHEMATIC**

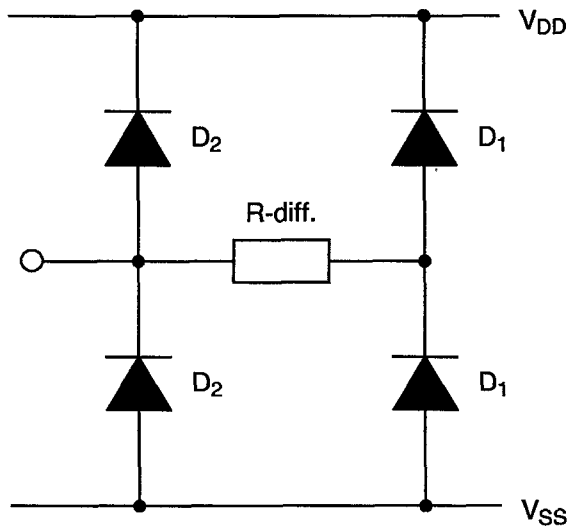
Not applicable.

**FIGURE 3(d) - FUNCTIONAL DIAGRAM**





**FIGURE 3(e) - INPUT PROTECTION NETWORK**



**2. APPLICABLE DOCUMENTS**

The following documents form part of this specification and shall be read in conjunction with it:-

- (a) ESA/SCC Generic Specification No. 9000 for Integrated Circuits.
- (b) MIL-STD-883, Test Methods and Procedures for Micro-electronics.

**3. TERMS, DEFINITIONS, ABBREVIATIONS, SYMBOLS AND UNITS**

For the purpose of this specification, the terms, definitions, abbreviations, symbols and units specified in ESA/SCC Basic Specification No. 21300 shall apply. In addition, the following abbreviations are used:

- $V_{IC}$  = Input Clamp Voltage
- $P_{DSO}$  = Single Output Power Dissipation
- CKT = Circuit
- $I_{OZ}$  = Output Leakage Current Third State
- $I_{LB}$  = Bias Leakage Current
- $V_Z$  = Zener Diode Voltage
- $t_{PHZ}$  = Propagation Delay, High Output to High Impedance
- $t_{PZH}$  = Propagation Delay, High Impedance to High Output
- $t_{PLZ}$  = Propagation Delay, Low Output to High Impedance
- $t_{PZL}$  = Propagation Delay, High Impedance to Low Output

**4. REQUIREMENTS****4.1 GENERAL**

The complete requirements for procurement of the integrated circuits specified herein shall be as stated in this specification and ESA/SCC Generic Specification No. 9000 for Integrated Circuits. Deviations from the Generic Specification, applicable to this specification only, are listed in Para. 4.2.

Deviations from the applicable Generic Specification and this Detail Specification, formally agreed with specific Manufacturers on the basis that the alternative requirements are equivalent to the ESA/SCC requirement and do not affect the components' reliability, are listed in the appendices attached to this specification.

**4.2 DEVIATIONS FROM GENERIC SPECIFICATION****4.2.1 Deviations from Special In-process Controls**

None.

**4.2.2 Deviations from Final Production Tests (Chart II)**

None.

**4.2.3 Deviations from Burn-in Tests (Chart III)****4.2.3.1 Deviations from High Temperature Reverse Bias (H.T.R.B.)**

Prior to operating power burn-in, a high temperature reverse bias (H.T.R.B.) screen at +125°C shall be added for the N-Channel and then for the P-Channel in accordance with Tables 5(a) and 5(b) of this specification. Each exposure to H.T.R.B. shall be 72 hours and Table 4 Parameter Drift Values shall be applied at 0 and 144 hours.

**4.2.4 Deviations from Qualification Tests (Chart IV)**

None.



**4.2.5 Deviations from Lot Acceptance Tests (Chart V)**

None.

**4.3 MECHANICAL REQUIREMENTS****4.3.1 Dimension Check**

The dimensions of the integrated circuits specified herein shall be checked. They shall conform to those shown in Figure 2.

**4.3.2 Weight**

The maximum weight of the integrated circuits specified herein shall be 1.5 grammes for the dual-in-line package, 0.6 grammes for the flat and SO packages and 0.52 grammes for the chip carrier package.

**4.4 MATERIALS AND FINISHES**

The materials and finishes shall be as specified herein. Where a definite material is not specified, a material which will enable the integrated circuits specified herein to meet the performance requirements of this specification shall be used. Acceptance or approval of any constituent material does not guarantee acceptance of the finished product.

**4.4.1 Case**

The case shall be hermetically sealed and have a metal body with hard glass seals or a ceramic body and the lids shall be welded, brazed or preform-soldered.

**4.4.2 Lead Material and Finish**

For dual-in-line and flat packages, the material shall be Type 'G' with either Type '4' or Type '2 or 8' finish in accordance with ESA/SCC Basic Specification No. 23500. For chip carrier packages the finish shall be Type '2' in accordance with ESA/SCC Basic Specification No. 23500. For SO ceramic packages, the material shall be Type 'G' with either Type '2' or Type '4' finish in accordance with ESA/SCC Basic Specification No. 23500. (See Table 1(a) for Type Variants).

**4.5 MARKING****4.5.1 General**

The marking of all components delivered to this specification shall be in accordance with the requirements of ESA/SCC Basic Specification No. 21700. Each component shall be marked in respect of:-

- (a) Lead Identification.
- (b) The SCC Component Number.
- (c) Traceability Information.

**4.5.2 Lead Identification**

For dual-in-line, flat and SO packages, an index shall be located at the top of the package in the position defined in Note 1 to Figure 2 or, alternatively, a tab may be used to identify Pin No. 1. The pin numbering must be read with the index or tab on the left-hand side. For chip carrier packages, the index shall be as defined by Figure 2(c).



4.5.3 The SCC Component Number

Each component shall bear the SCC Component Number which shall be constituted and marked as follows:

Detail Specification Number		920204401B
Type Variant, as applicable		
Testing Level (B or C, as appropriate)		

4.5.4 Traceability Information

Each component shall be marked in respect of traceability information in accordance with the requirements of ESA/SCC Basic Specification No. 21700.

4.6 ELECTRICAL MEASUREMENTS

4.6.1 Electrical Measurements at Room Temperature

The parameters to be measured in respect of electrical characteristics are scheduled in Table 2. Unless otherwise specified, the measurements shall be performed at  $T_{amb} = +22 \pm 3$  °C.

4.6.2 Electrical Measurements at High and Low Temperatures

The parameters to be measured at high and low temperatures are scheduled in Table 3. The measurements shall be performed at  $T_{amb} = +125(+0-5)$  °C and  $-55(+5-0)$  °C respectively.

4.6.3 Circuits for Electrical Measurements

Circuits and functional test sequence for use in performing electrical measurements listed in Tables 2 and 3 of this specification are shown in Figure 4.

4.7 BURN-IN TESTS

4.7.1 Parameter Drift Values

The parameter drift values applicable to burn-in are specified in Table 4 of this specification. Unless otherwise stated, measurements shall be performed at  $+22 \pm 3$  °C. The parameter drift values ( $\Delta$ ) applicable to the parameters scheduled, shall not be exceeded. In addition to these drift value requirements, the appropriate limit value specified for a given parameter in Table 2 shall not be exceeded.

4.7.2 Conditions for H.T.R.B. and Burn-in

The requirements for H.T.R.B. and Burn-in are specified in Section 7 of ESA/SCC Generic Specification No. 9000. The conditions for H.T.R.B. and Burn-in shall be as specified in Tables 5(a), 5(b) and 5(c) of this specification.

4.7.3 Electrical Circuits for H.T.R.B. and Burn-in

Circuits for use in performing the H.T.R.B. and Burn-in tests are shown in Figures 5(a), 5(b) and 5(c) of this specification.

**TABLE 2 - ELECTRICAL MEASUREMENTS AT ROOM TEMPERATURE - d.c. PARAMETERS**

No.	CHARACTERISTICS	SYMBOL	TEST METHOD MIL-STD 883	TEST FIG.	TEST CONDITIONS (PINS UNDER TEST D/F = DIP AND FP C = CCP)	LIMITS		UNIT
						MIN	MAX	
1	Functional Test	-	-	4(a)	Verify Truth Table without Load. $V_{DD} = 3V_{dc}$ , $V_{SS} = 0V_{dc}$ Notes 1 and 2	-	-	-
2	Functional Test	-	-	4(a)	Verify Truth Table without Load. $V_{DD} = 15V_{dc}$ , $V_{SS} = 0V_{dc}$ Notes 1 and 2	-	-	-
3 to 14	Quiescent Current	$I_{DD}$	3005	4(b)	$V_{IL} = 0V_{dc}$ , $V_{IH} = 15V_{dc}$ $V_{DD} = 15V_{dc}$ , $V_{SS} = 0V_{dc}$ Note 3 (Pin D/F 16) (Pin C 20)	-	$\pm 80$	$\mu A$
15 to 18	Input Current Low Level	$I_{IL}$	3009	4(c)	$V_{IN}$ (Under Test) = $0V_{dc}$ $V_{IN}$ (Signal In and 2C1) = $0V_{dc}$ $V_{IN}$ (Remaining Inputs) = $15V_{dc}$ $V_{DD} = 15V_{dc}$ , $V_{SS} = 0V_{dc}$ (Pins D/F 3-5-9-12) (Pins C 4-6-11-15)	-	-0.1	$\mu A$
19 to 22	Input Current High Level	$I_{IH}$	3010	4(d)	$V_{IN}$ (Under Test) = $15V_{dc}$ $V_{IN}$ (Remaining Inputs) = $0V_{dc}$ $V_{DD} = 15V_{dc}$ , $V_{SS} = 0V_{dc}$ (Pins D/F 3-5-9-12) (Pins C 4-6-11-15)	-	0.1	$\mu A$
23 to 28	Output Voltage Low Level	$V_{OL}$	3007	4(e)	For Input Conditions see Table of Figure 4(e) $V_{IN}$ (Inhibit and $R_2$ ) = $15V_{dc}$ $V_{IN}$ (VCO In and $R_1$ ) = $0V_{dc}$ $V_{OUT}$ = Open $V_{DD} = 15V_{dc}$ , $V_{SS} = 0V_{dc}$ (Pins D/F 1-2-4-6-7-13) (Pins C 1-2-5-7-9-16)	-	0.05	V

**NOTES:** See Page 26.



**TABLE 2 - ELECTRICAL MEASUREMENTS AT ROOM TEMPERATURE - d.c. PARAMETERS (CONT'D)**

No.	CHARACTERISTICS	SYMBOL	TEST METHOD MIL-STD 883	TEST FIG.	TEST CONDITIONS (PINS UNDER TEST D/F = DIP AND FP C = CCP)	LIMITS		UNIT
						MIN	MAX	
29 to 32	Output Voltage High Level	$V_{OH}$	3006	4(f)	For Input Conditions see Table of Figure 4(e) $V_{IN}(R_2) = 15Vdc$ $V_{IN}(VCO\ In, Inhibit, R_1, 1C1\ and\ 2C1) = 0Vdc$ $V_{OUT} = Open$ $V_{DD} = 15Vdc, V_{SS} = 0Vdc$ (Pins D/F 1-2-4-13) (Pins C 1-2-5-16)	14.95	-	V
33 to 38	Output Drive Current N-Channel	$I_{OL1}$	-	4(g)	For Input Conditions see Table of Figure 4(e) $V_{IN}(Inhibit\ and\ R_2) = 5Vdc$ $V_{IN}(VCO\ In\ and\ R_1) = 0Vdc$ $V_{OUT} = 0.4Vdc$ $V_{DD} = 5Vdc, V_{SS} = 0Vdc$ Note 4 (Pins D/F 1-2-4-6-7-13) (Pins C 1-2-5-7-9-16)	0.51	-	mA
39 to 44	Output Drive Current N-Channel	$I_{OL2}$	-	4(g)	For Input Conditions see Table of Figure 4(e) $V_{IN}(Inhibit\ and\ R_2) = 15Vdc$ $V_{IN}(VCO\ In\ and\ R_1) = 0Vdc$ $V_{OUT} = 1.5Vdc$ $V_{DD} = 15Vdc, V_{SS} = 0Vdc$ Note 4 (Pins D/F 1-2-4-6-7-13) (Pins C 1-2-5-7-9-16)	3.4	-	mA
45 to 48	Output Drive Current P-Channel	$I_{OH1}$	-	4(h)	For Input Conditions see Table of Figure 4(e) $V_{IN}(R_2) = 5Vdc$ $V_{IN}(VCO\ In, Inhibit, R_1, 1C1\ and\ 2C1) = 0Vdc$ $V_{OUT} = 4.6Vdc$ $V_{DD} = 5Vdc, V_{SS} = 0Vdc$ Note 4 (Pins D/F 1-2-4-13) (Pins C 1-2-5-16)	-0.51	-	mA

**NOTES:** See Page 26.



**TABLE 2 - ELECTRICAL MEASUREMENTS AT ROOM TEMPERATURE - d.c. PARAMETERS (CONT'D)**

No.	CHARACTERISTICS	SYMBOL	TEST METHOD MIL-STD 883	TEST FIG.	TEST CONDITIONS (PINS UNDER TEST D/F = DIP AND FP C = CCP)	LIMITS		UNIT
						MIN	MAX	
49 to 52	Output Drive Current P-Channel	$I_{OH2}$	-	4(h)	For Input Conditions see Table of Figure 4(e) $V_{IN}(R_2) = 15Vdc$ $V_{IN}(VCO In, Inhibit, R_1, 1C1 \text{ and } 2C1) = 0Vdc$ $V_{OUT} = 13.5Vdc$ $V_{DD} = 15Vdc, V_{SS} = 0Vdc$ Note 4 (Pins D/F 1-2-4-13) (Pins C 1-2-5-16)	-3.4	-	mA
53	Output Leakage Current Third State (1)	$I_{OZ1}$	-	4(i)	For Input Conditions see Table of Figure 4(i) $V_{IN}(Inhibit \text{ and } R_2) = 15Vdc$ $V_{IN}(VCO In) = 0Vdc$ $V_{OUT} = 15Vdc$ $V_{DD} = 15Vdc, V_{SS} = 0Vdc$ (Pin D/F 13) (Pin C 16)	-	0.4	$\mu A$
54	Output Leakage Current Third State (2)	$I_{OZ2}$	-	4(i)	For Input Conditions see Table of Figure 4(i) $V_{IN}(Inhibit \text{ and } R_2) = 15Vdc$ $V_{IN}(VCO In) = 0Vdc$ $V_{OUT} = 0Vdc$ $V_{DD} = 15Vdc, V_{SS} = 0Vdc$ (Pin D/F 13) (Pin C 16)	-	-0.4	$\mu A$
55	Input Voltage Low Level (Noise Immunity) (Functional Test)	$V_{IL1}$	-	4(a)	$V_{IL} = 1.5Vdc$ $V_{IH} = 3.5Vdc$ $V_{DD} = 5Vdc, V_{SS} = 0Vdc$ Note 5 (Pins D/F 1-2-4-6-7-13) (Pins C 1-2-5-7-9-16)	4.5	-	V
	Input Voltage High Level (Noise Immunity) (Functional Test)	$V_{IH1}$	-			-	0.5	
56	Input Voltage Low Level (Noise Immunity) (Functional Test)	$V_{IL2}$	-	4(a)	$V_{IL} = 4.0Vdc$ $V_{IH} = 11Vdc$ $V_{DD} = 15Vdc, V_{SS} = 0Vdc$ Note 5 (Pins D/F 1-2-4-6-7-13) (Pins C 1-2-5-7-9-16)	13.5	-	V
	Input Voltage High Level (Noise Immunity) (Functional Test)	$V_{IH2}$	-			-	1.5	

**NOTES:** See Page 26.

**TABLE 2 - ELECTRICAL MEASUREMENTS AT ROOM TEMPERATURE - d.c. PARAMETERS (CONT'D)**

No.	CHARACTERISTICS	SYMBOL	TEST METHOD MIL-STD 883	TEST FIG.	TEST CONDITIONS (PINS UNDER TEST D/F = DIP AND FP C = CCP)	LIMITS		UNIT
						MIN	MAX	
57	Bias Leakage Current (1)	$I_{LB1}$	-	4(j)	$V_{IN}$ (Comparator and VCO In) = 0Vdc $V_{IN}$ (Inhibit and R <sub>2</sub> ) = 15Vdc Signal In = Open $V_{DD}$ = 15Vdc, $V_{SS}$ = 0Vdc (Pin D/F 8) (Pin C 10)	-	-1.5	mA
58	Bias Leakage Current (2)	$I_{LB2}$	-	4(j)	$V_{IN}$ (Signal In) = 0Vdc $V_{IN}$ (Comparator and VCO In) = 0Vdc $V_{IN}$ (Inhibit and R <sub>2</sub> ) = 15Vdc $V_{DD}$ = 15Vdc, $V_{SS}$ = 0Vdc (Pin D/F 14) (Pin C 17)	-	-150	$\mu$ A
59	Bias Leakage Current (3)	$I_{LB3}$	-	4(j)	$V_{IN}$ (Signal In) = 15Vdc $V_{IN}$ (Comparator and VCO In) = 0Vdc $V_{IN}$ (Inhibit and R <sub>2</sub> ) = 15Vdc $V_{DD}$ = 15Vdc, $V_{SS}$ = 0Vdc (Pin D/F 14) (Pin C 17)	-	150	$\mu$ A
60	Threshold Voltage N-Channel	$V_{THN}$	-	4(k)	Comparator In, Inhibit, 1C1, 2C1, Signal In and $V_{SS}$ = -5V $V_{IN}$ (Remaining Inputs) = 0Vdc $I$ (Demod. Out) = -10 $\mu$ A $V_{DD}$ = 0Vdc (Pin D/F 10) (Pin C 12)	-0.7	-3.0	V
61	Threshold Voltage P-Channel	$V_{THP}$	-	4(l)	$V_{DD}$ at Ground. $I_{(R2)}$ = -10 $\mu$ A $V_{IN}$ (Remaining Inputs) = -5Vdc $V_{SS}$ = -5Vdc, (Pin D/F 12) (Pin C 15)	-0.7	-3.0	V
62	Zener Voltage	$V_Z$	-	4(m)	$I_Z$ = 50 $\mu$ A (Pin D/F 15) (Pin C 19)	4.45	7.5	V

**NOTES:** See Page 26.



**TABLE 2 - ELECTRICAL MEASUREMENTS AT ROOM TEMPERATURE - d.c. PARAMETERS (CONT'D)**

No.	CHARACTERISTICS	SYMBOL	TEST METHOD MIL-STD 883	TEST FIG.	TEST CONDITIONS (PINS UNDER TEST D/F = DIP AND FP C = CCP)	LIMITS		UNIT
						MIN	MAX	
63 to 69	Input Clamp Voltage (to $V_{SS}$ )	$V_{IC1}$	-	4(n)	$I_{IN}$ (Under Test) = $-100\mu A$ $V_{DD}$ = Open, $V_{SS}$ = 0Vdc All Other Pins Open (Pins D/F 3-5-6-7-9-12-14) (Pins C 4-6-7-9-11-15-17)	-	-2.0	V
70 to 76	Input Clamp Voltage (to $V_{DD}$ )	$V_{IC2}$	-	4(o)	$V_{IN}$ (Under Test) = 6Vdc $V_{SS}$ = Open, $R = 30k\Omega$ (Pins D/F 3-5-6-7-9-12-14) (Pins C 4-6-7-9-11-15-17)	3.0	-	V

**NOTES:** See Page 26.

**TABLE 2 - ELECTRICAL MEASUREMENTS AT ROOM TEMPERATURE - a.c. PARAMETERS**

No.	CHARACTERISTICS	SYMBOL	TEST METHOD MIL-STD 883	TEST FIG.	TEST CONDITIONS (PINS UNDER TEST D/F = DIP AND FP C = CCP)	LIMITS		UNIT
						MIN	MAX	
77 to 78	Input Capacitance 1	$C_{IN1}$	3012	4(p)	$V_{IN}$ (Not Under Test) = 0Vdc $V_{DD} = V_{SS} = 0Vdc$ Note 6 (Pins D/F 3-5) (Pins C 4-6)	-	7.5	pF
79	Input Capacitance 2	$C_{IN2}$	3012	4(p)	$V_{IN}$ (Not Under Test) = 0Vdc $V_{DD} = V_{SS} = 0Vdc$ Note 6 (Pin D/F 9) (Pin C 11)	-	35	pF
80	Propagation Delay Time Low to High	$t_{PLH}$	3003	4(q)	$V_{IN}$ (Under Test) = Pulse Generator $V_{IN}$ (Remaining Inputs) = 0Vdc $V_{DD} = 5Vdc, V_{SS} = 0Vdc$ Note 7 <u>Pins D/F</u> <u>Pins C</u> 3 to 2        4 to 2	-	650	ns
81	Propagation Delay Time High to Low	$t_{PHL}$	3003	4(q)	$V_{IN}$ (Under Test) = Pulse Generator $V_{IN}$ (Remaining Inputs) = 0Vdc $V_{DD} = 5Vdc, V_{SS} = 0Vdc$ Note 7 <u>Pins D/F</u> <u>Pins C</u> 14 to 2      17 to 2	-	400	ns
82	Propagation Delay Time High Impedance to Low Output	$t_{PZL}$	-	4(r)	$V_{IN}$ (Under Test) = Pulse Generator $V_{IN}$ (Remaining Inputs) = 0Vdc $V_{DD} = 5Vdc, V_{SS} = 0Vdc$ Note 7 <u>Pins D/F</u> <u>Pins C</u> 3 to 13      4 to 16	-	550	ns

**NOTES:** See Page 26.



**TABLE 2 - ELECTRICAL MEASUREMENTS AT ROOM TEMPERATURE - a.c. PARAMETERS (CONT'D)**

No.	CHARACTERISTICS	SYMBOL	TEST METHOD MIL-STD 883	TEST FIG.	TEST CONDITIONS (PINS UNDER TEST D/F = DIP AND FP C = CCP)	LIMITS		UNIT
						MIN	MAX	
83	Propagation Delay Time Low Output to High Impedance	$t_{PLZ}$	-	4(r)	$V_{IN}$ (Under Test) = Pulse Generator $V_{IN}$ (Remaining Inputs) = 0Vdc $V_{DD} = 5Vdc$ , $V_{SS} = 0Vdc$ Note 7 Pins D/F    Pins C 14 to 13    17 to 16	-	550	ns
84	Propagation Delay Time High Impedance to High Output	$t_{PZH}$	-	4(r)	$V_{IN}$ (Under Test) = Pulse Generator $V_{IN}$ (Remaining Inputs) = 0Vdc $V_{DD} = 5Vdc$ , $V_{SS} = 0Vdc$ Note 7 Pins D/F    Pins C 14 to 13    17 to 16	-	420	ns
85	Propagation Delay Time High Output to High Impedance	$t_{PHZ}$	-	4(r)	$V_{IN}$ (Under Test) = Pulse Generator $V_{IN}$ (Remaining Inputs) = 0Vdc $V_{DD} = 5Vdc$ , $V_{SS} = 0Vdc$ Note 7 Pins D/F    Pins C 3 to 13    4 to 16	-	420	ns
86	Transition Time Low to High	$t_{TLH}$	3004	4(q)	$V_{IN}$ (Under Test) = Pulse Generator $V_{IN}$ (Remaining Inputs) = 0Vdc $V_{DD} = 5Vdc$ , $V_{SS} = 0Vdc$ Note 7 (Pin D/F 2) (Pin C 2)	-	150	ns
87	Transition Time High to Low	$t_{THL}$	3004	4(q)	$V_{IN}$ (Under Test) = Pulse Generator $V_{IN}$ (All Other Inputs) = 0Vdc $V_{DD} = 5Vdc$ , $V_{SS} = 0Vdc$ Note 7 (Pin D/F 2) (Pin C 2)	-	150	ns

**NOTES:** See Page 26.

**TABLE 2 - ELECTRICAL MEASUREMENTS AT ROOM TEMPERATURE - a.c. PARAMETERS (CONT'D)**

No.	CHARACTERISTICS	SYMBOL	TEST METHOD MIL-STD 883	TEST FIG.	TEST CONDITIONS (PINS UNDER TEST D/F = DIP AND FP C = CCP)	LIMITS		UNIT
						MIN	MAX	
88	Maximum Output Frequency of VCO	$f_{max}$	-	4(r)	$R_1 = 10k\Omega$ , $C_1 = 50pF$ , $R_2 = \infty$ $V_{DD} = 5V_{dc}$ , $V_{SS} = 0V_{dc}$ Note 7 (Pin D/F 4) (Pin C 5)	0.3	-	MHz

**NOTES**

- GO-NO-GO Test, each pattern of Test Table 4(a).  
 $V_{OH} \geq V_{DD} - 0.5V_{dc}$        $V_{OL} \leq 0.5V_{dc}$
- Maximum time to output comparator strobe 300 $\mu$ sec.
- Test  $I_{DD}$  at the 12 conditions indicated in Figure 4(b).
- Interchange of forcing and measuring function is permitted.
- This is performed as a Functional Test in which extreme  $V_{IN}$  conditions are applied and output voltage is measured.
- Measurement performed on a sample basis, LTPD7 or less, with a Capacitance Bridge connected between each input under test and  $V_{SS}$ , only for Lots where LAT Level 2 is to be performed. (For LTPD sampling plan, see Annexe I of ESA/SCC 9000).
- Measurement performed on a sample basis, LTPD7 or less, (see Annexe I of ESA/SCC 9000).



**TABLE 3(a) - ELECTRICAL MEASUREMENTS AT HIGH TEMPERATURE, +125(+0-5) °C**

No.	CHARACTERISTICS	SYMBOL	TEST METHOD MIL-STD 883	TEST FIG.	TEST CONDITIONS (PINS UNDER TEST D/F = DIP AND FP C = CCP)	LIMITS		UNIT
						MIN	MAX	
1	Functional Test	-	-	4(a)	Verify Truth Table without Load. $V_{DD} = 3V_{dc}$ , $V_{SS} = 0V_{dc}$ Notes 1 and 2	-	-	-
2	Functional Test	-	-	4(a)	Verify Truth Table without Load. $V_{DD} = 15V_{dc}$ , $V_{SS} = 0V_{dc}$ Notes 1 and 2	-	-	-
3 to 14	Quiescent Current	$I_{DD}$	3005	4(b)	$V_{IL} = 0V_{dc}$ , $V_{IH} = 15V_{dc}$ $V_{DD} = 15V_{dc}$ , $V_{SS} = 0V_{dc}$ Note 3 (Pin D/F 16) (Pin C 20)	-	$\pm 2.4$	mA
15 to 18	Input Current Low Level	$I_{IL}$	3009	4(c)	$V_{IN}$ (Under Test) = $0V_{dc}$ $V_{IN}$ (Signal In and 2C1) = $0V_{dc}$ $V_{IN}$ (Remaining Inputs) = $15V_{dc}$ $V_{DD} = 15V_{dc}$ , $V_{SS} = 0V_{dc}$ (Pins D/F 3-5-9-12) (Pins C 4-6-11-15)	-	-1.0	$\mu A$
19 to 22	Input Current High Level	$I_{IH}$	3010	4(d)	$V_{IN}$ (Under Test) = $15V_{dc}$ $V_{IN}$ (Remaining Inputs) = $0V_{dc}$ $V_{DD} = 15V_{dc}$ , $V_{SS} = 0V_{dc}$ (Pins D/F 3-5-9-12) (Pins C 4-6-11-15)	-	1.0	$\mu A$
23 to 28	Output Voltage Low Level	$V_{OL}$	3007	4(e)	For Input Conditions see Table of Figure 4(e) $V_{IN}$ (Inhibit and $R_2$ ) = $15V_{dc}$ $V_{IN}$ (VCO In and $R_1$ ) = $0V_{dc}$ $V_{OUT} = \text{Open}$ $V_{DD} = 15V_{dc}$ , $V_{SS} = 0V_{dc}$ (Pins D/F 1-2-4-6-7-13) (Pins C 1-2-5-7-9-16)	-	0.05	V

**NOTES:** See Page 26.

**TABLE 3(a) - ELECTRICAL MEASUREMENTS AT HIGH TEMPERATURE, +125(+0-5) °C (CONT'D)**

No.	CHARACTERISTICS	SYMBOL	TEST METHOD MIL-STD 883	TEST FIG.	TEST CONDITIONS (PINS UNDER TEST D/F = DIP AND FP C = CCP)	LIMITS		UNIT
						MIN	MAX	
29 to 32	Output Voltage High Level	$V_{OH}$	3006	4(f)	For Input Conditions see Table of Figure 4(e) $V_{IN}(R_2) = 15Vdc$ $V_{IN}(VCO\ In, Inhibit, R_1,$ $1C1\ and\ 2C1) = 0Vdc$ $V_{OUT} = Open$ $V_{DD} = 15Vdc, V_{SS} = 0Vdc$ (Pins D/F 1-2-4-13) (Pins C 1-2-5-16)	14.95	-	V
33 to 38	Output Drive Current N-Channel	$I_{OL1}$	-	4(g)	For Input Conditions see Table of Figure 4(e) $V_{IN}(Inhibit\ and\ R_2)$ $= 5Vdc$ $V_{IN}(VCO\ In\ and\ R_1)$ $= 0Vdc$ $V_{OUT} = 0.4Vdc$ $V_{DD} = 5Vdc, V_{SS} = 0Vdc$ Note 4 (Pins D/F 1-2-4-6-7-13) (Pins C 1-2-5-7-9-16)	360	-	$\mu A$
39 to 44	Output Drive Current N-Channel	$I_{OL2}$	-	4(g)	For Input Conditions see Table of Figure 4(e) $V_{IN}(Inhibit\ and\ R_2)$ $= 15Vdc$ $V_{IN}(VCO\ In\ and\ R_1)$ $= 0Vdc$ $V_{OUT} = 1.5Vdc$ $V_{DD} = 15Vdc, V_{SS} = 0Vdc$ Note 4 (Pins D/F 1-2-4-6-7-13) (Pins C 1-2-5-7-9-16)	2.4	-	mA
45 to 48	Output Drive Current P-Channel	$I_{OH1}$	-	4(h)	For Input Conditions see Table of Figure 4(e) $V_{IN}(R_2) = 5Vdc$ $V_{IN}(VCO\ In, Inhibit, R_1,$ $1C1\ and\ 2C1) = 0Vdc$ $V_{OUT} = 4.6Vdc$ $V_{DD} = 5Vdc, V_{SS} = 0Vdc$ Note 4 (Pins D/F 1-2-4-13) (Pins C 1-2-5-16)	-360	-	$\mu A$

**NOTES:** See Page 26.

**TABLE 3(a) - ELECTRICAL MEASUREMENTS AT HIGH TEMPERATURE, +125(+0-5) °C (CONT'D)**

No.	CHARACTERISTICS	SYMBOL	TEST METHOD MIL-STD 883	TEST FIG.	TEST CONDITIONS (PINS UNDER TEST D/F = DIP AND FP C = CCP)	LIMITS		UNIT
						MIN	MAX	
49 to 52	Output Drive Current P-Channel	$I_{OH2}$	-	4(h)	For Input Conditions see Table of Figure 4(e) $V_{IN}(R_2) = 15Vdc$ $V_{IN}(VCO\ In, Inhibit, R_1, 1C1\ and\ 2C1) = 0Vdc$ $V_{OUT} = 13.5Vdc$ $V_{DD} = 15Vdc, V_{SS} = 0Vdc$ Note 4 (Pins D/F 1-2-4-13) (Pins C 1-2-5-16)	-2.4	-	mA
53	Output Leakage Current Third State (1)	$I_{OZ1}$	-	4(i)	For Input Conditions see Table of Figure 4(i) $V_{IN}(Inhibit\ and\ R_2) = 15Vdc$ $V_{IN}(VCO\ In) = 0Vdc$ $V_{OUT} = 15Vdc$ $V_{DD} = 15Vdc, V_{SS} = 0Vdc$ (Pin D/F 13) (Pin C 16)	-	12	$\mu A$
54	Output Leakage Current Third State (2)	$I_{OZ2}$	-	4(i)	For Input Conditions see Table of Figure 4(i) $V_{IN}(Inhibit\ and\ R_2) = 15Vdc$ $V_{IN}(VCO\ In) = 0Vdc$ $V_{OUT} = 0Vdc$ $V_{DD} = 15Vdc, V_{SS} = 0Vdc$ (Pin D/F 13) (Pin C 16)	-	-12	$\mu A$
55	Input Voltage Low Level (Noise Immunity) (Functional Test)	$V_{IL1}$	-	4(a)	$V_{IL} = 1.5Vdc$ $V_{IH} = 3.5Vdc$ $V_{DD} = 5Vdc, V_{SS} = 0Vdc$ Note 5 (Pins D/F 1-2-4-6-7-13) (Pins C 1-2-5-7-9-16)	4.5	-	V
	Input Voltage High Level (Noise Immunity) (Functional Test)	$V_{IH1}$	-			-	0.5	
56	Input Voltage Low Level (Noise Immunity) (Functional Test)	$V_{IL2}$	-	4(a)	$V_{IL} = 4.0Vdc$ $V_{IH} = 11Vdc$ $V_{DD} = 15Vdc, V_{SS} = 0Vdc$ Note 5 (Pins D/F 1-2-4-6-7-13) (Pins C 1-2-5-7-9-16)	13.5	-	V
	Input Voltage High Level (Noise Immunity) (Functional Test)	$V_{IH2}$	-			-	1.5	

**NOTES:** See Page 26.



**TABLE 3(a) - ELECTRICAL MEASUREMENTS AT HIGH TEMPERATURE, +125(+0-5) °C (CONT'D)**

No.	CHARACTERISTICS	SYMBOL	TEST METHOD MIL-STD 883	TEST FIG.	TEST CONDITIONS (PINS UNDER TEST D/F = DIP AND FP C = CCP)	LIMITS		UNIT
						MIN	MAX	
57	Bias Leakage Current (1)	$I_{LB1}$	-	4(j)	$V_{IN}$ (Comparator and VCO In) = 0Vdc $V_{IN}$ (Inhibit and R <sub>2</sub> ) = 15Vdc Signal In = Open $V_{DD}$ = 15Vdc, $V_{SS}$ = 0Vdc (Pin D/F 8) (Pin C 10)	-	-1.5	mA
58	Bias Leakage Current (2)	$I_{LB2}$	-	4(j)	$V_{IN}$ (Signal In) = 0Vdc $V_{IN}$ (Comparator and VCO In) = 0Vdc $V_{IN}$ (Inhibit and R <sub>2</sub> ) = 15Vdc $V_{DD}$ = 15Vdc, $V_{SS}$ = 0Vdc (Pin D/F 14) (Pin C 17)	-	-120	μA
59	Bias Leakage Current (3)	$I_{LB3}$	-	4(j)	$V_{IN}$ (Signal In) = 15Vdc $V_{IN}$ (Comparator and VCO In) = 0Vdc $V_{IN}$ (Inhibit and R <sub>2</sub> ) = 15Vdc $V_{DD}$ = 15Vdc, $V_{SS}$ = 0Vdc (Pin D/F 14) (Pin C 17)	-	120	μA
60	Threshold Voltage N-Channel	$V_{THN}$	-	4(k)	Comparator In, Inhibit, 1C1, 2C1, Signal In and $V_{SS}$ = -5V $V_{IN}$ (Remaining Inputs) = 0Vdc I (Demod. Out) = -10μA $V_{DD}$ = 0Vdc (Pin D/F 10) (Pin C 12)	-0.3	-3.5	V
61	Threshold Voltage P-Channel	$V_{THP}$	-	4(l)	$V_{DD}$ at Ground. $I_{(R2)}$ = -10μA $V_{IN}$ (Remaining Inputs) = -5Vdc $V_{SS}$ = -5Vdc (Pin D/F 12) (Pin C 15)	-0.3	-3.5	V
62	Zener Voltage	$V_Z$	-	4(m)	$I_Z$ = 50μA (Pin D/F 15) (Pin C 19)	4.45	7.75	V

**NOTES:** See Page 26.

**TABLE 3(b) - ELECTRICAL MEASUREMENTS AT LOW TEMPERATURE,  $-55(+5-0)^\circ\text{C}$** 

No.	CHARACTERISTICS	SYMBOL	TEST METHOD MIL-STD 883	TEST FIG.	TEST CONDITIONS (PINS UNDER TEST D/F = DIP AND FP C = CCP)	LIMITS		UNIT
						MIN	MAX	
1	Functional Test	-	-	4(a)	Verify Truth Table without Load. $V_{DD} = 3\text{Vdc}$ , $V_{SS} = 0\text{Vdc}$ Notes 1 and 2	-	-	-
2	Functional Test	-	-	4(a)	Verify Truth Table without Load. $V_{DD} = 15\text{Vdc}$ , $V_{SS} = 0\text{Vdc}$ Notes 1 and 2	-	-	-
3 to 14	Quiescent Current	$I_{DD}$	3005	4(b)	$V_{IL} = 0\text{Vdc}$ , $V_{IH} = 15\text{Vdc}$ $V_{DD} = 15\text{Vdc}$ , $V_{SS} = 0\text{Vdc}$ Note 3 (Pin D/F 16) (Pin C 20)	-	$\pm 80$	$\mu\text{A}$
15 to 18	Input Current Low Level	$I_{IL}$	3009	4(c)	$V_{IN}$ (Under Test) = $0\text{Vdc}$ $V_{IN}$ (Signal In and 2C1) = $0\text{Vdc}$ $V_{IN}$ (Remaining Inputs) = $15\text{Vdc}$ $V_{DD} = 15\text{Vdc}$ , $V_{SS} = 0\text{Vdc}$ (Pins D/F 3-5-9-12) (Pins C 4-6-11-15)	-	-0.1	$\mu\text{A}$
19 to 22	Input Current High Level	$I_{IH}$	3010	4(d)	$V_{IN}$ (Under Test) = $15\text{Vdc}$ $V_{IN}$ (Remaining Inputs) = $0\text{Vdc}$ $V_{DD} = 15\text{Vdc}$ , $V_{SS} = 0\text{Vdc}$ (Pins D/F 3-5-9-12) (Pins C 4-6-11-15)	-	0.1	$\mu\text{A}$
23 to 28	Output Voltage Low Level	$V_{OL}$	3007	4(e)	For Input Conditions see Table of Figure 4(e) $V_{IN}$ (Inhibit and $R_2$ ) = $15\text{Vdc}$ $V_{IN}$ (VCO In and $R_1$ ) = $0\text{Vdc}$ $V_{OUT} = \text{Open}$ $V_{DD} = 15\text{Vdc}$ , $V_{SS} = 0\text{Vdc}$ (Pins D/F 1-2-4-6-7-13) (Pins C 1-2-5-7-9-16)	-	0.05	V

**NOTES:** See Page 26.

**TABLE 3(b) - ELECTRICAL MEASUREMENTS AT LOW TEMPERATURE,  $-55(+5-0)$  °C (CONT'D)**

No.	CHARACTERISTICS	SYMBOL	TEST METHOD MIL-STD 883	TEST FIG.	TEST CONDITIONS (PINS UNDER TEST D/F = DIP AND FP C = CCP)	LIMITS		UNIT
						MIN	MAX	
29 to 32	Output Voltage High Level	$V_{OH}$	3006	4(f)	For Input Conditions see Table of Figure 4(e) $V_{IN}(R_2) = 15Vdc$ $V_{IN}(VCO\ In, Inhibit, R_1, 1C1\ and\ 2C1) = 0Vdc$ $V_{OUT} = Open$ $V_{DD} = 15Vdc, V_{SS} = 0Vdc$ (Pins D/F 1-2-4-13) (Pins C 1-2-5-16)	14.95	-	V
33 to 38	Output Drive Current N-Channel	$I_{OL1}$	-	4(g)	For Input Conditions see Table of Figure 4(e) $V_{IN}(Inhibit\ and\ R_2) = 5Vdc$ $V_{IN}(VCO\ In\ and\ R_1) = 0Vdc$ $V_{OUT} = 0.4Vdc$ $V_{DD} = 5Vdc, V_{SS} = 0Vdc$ Note 4 (Pins D/F 1-2-4-6-7-13) (Pins C 1-2-5-7-9-16)	640	-	$\mu A$
39 to 44	Output Drive Current N-Channel	$I_{OL2}$	-	4(g)	For Input Conditions see Table of Figure 4(e) $V_{IN}(Inhibit\ and\ R_2) = 15Vdc$ $V_{IN}(VCO\ In\ and\ R_1) = 0Vdc$ $V_{OUT} = 1.5Vdc$ $V_{DD} = 15Vdc, V_{SS} = 0Vdc$ Note 4 (Pins D/F 1-2-4-6-7-13) (Pins C 1-2-5-7-9-16)	4.2	-	mA
45 to 48	Output Drive Current P-Channel	$I_{OH1}$	-	4(h)	For Input Conditions see Table of Figure 4(e) $V_{IN}(R_2) = 5Vdc$ $V_{IN}(VCO\ In, Inhibit, R_1, 1C1\ and\ 2C1) = 0Vdc$ $V_{OUT} = 4.6Vdc$ $V_{DD} = 5Vdc, V_{SS} = 0Vdc$ Note 4 (Pins D/F 1-2-4-13) (Pins C 1-2-5-16)	-640	-	$\mu A$

**NOTES:** See Page 26.





**TABLE 3(b) - ELECTRICAL MEASUREMENTS AT LOW TEMPERATURE,  $-55(+5-0)^\circ\text{C}$  (CONT'D)**

No.	CHARACTERISTICS	SYMBOL	TEST METHOD MIL-STD 883	TEST FIG.	TEST CONDITIONS (PINS UNDER TEST D/F = DIP AND FP C = CCP)	LIMITS		UNIT
						MIN	MAX	
49 to 52	Output Drive Current P-Channel	$I_{OH2}$	-	4(h)	For Input Conditions see Table of Figure 4(e) $V_{IN}(R_2) = 15\text{Vdc}$ $V_{IN}(\text{VCO In, Inhibit, } R_1, 1C1 \text{ and } 2C1) = 0\text{Vdc}$ $V_{OUT} = 13.5\text{Vdc}$ $V_{DD} = 15\text{Vdc}, V_{SS} = 0\text{Vdc}$ Note 4 (Pins D/F 1-2-4-13) (Pins C 1-2-5-16)	-4.2	-	mA
53	Output Leakage Current Third State (1)	$I_{OZ1}$	-	4(i)	For Input Conditions see Table of Figure 4(i) $V_{IN}(\text{Inhibit and } R_2) = 15\text{Vdc}$ $V_{IN}(\text{VCO In}) = 0\text{Vdc}$ $V_{OUT} = 15\text{Vdc}$ $V_{DD} = 15\text{Vdc}, V_{SS} = 0\text{Vdc}$ (Pin D/F 13) (Pin C 16)	-	0.4	$\mu\text{A}$
54	Output Leakage Current Third State (2)	$I_{OZ2}$	-	4(i)	For Input Conditions see Table of Figure 4(i) $V_{IN}(\text{Inhibit and } R_2) = 15\text{Vdc}$ $V_{IN}(\text{VCO In}) = 0\text{Vdc}$ $V_{OUT} = 0\text{Vdc}$ $V_{DD} = 15\text{Vdc}, V_{SS} = 0\text{Vdc}$ (Pin D/F 13) (Pin C 16)	-	-0.4	$\mu\text{A}$
55	Input Voltage Low Level (Noise Immunity) (Functional Test)	$V_{IL1}$	-	4(a)	$V_{IL} = 1.5\text{Vdc}$ $V_{IH} = 3.5\text{Vdc}$ $V_{DD} = 5\text{Vdc}, V_{SS} = 0\text{Vdc}$ Note 5 (Pins D/F 1-2-4-6-7-13) (Pins C 1-2-5-7-9-16)	4.5	-	V
	Input Voltage High Level (Noise Immunity) (Functional Test)	$V_{IH1}$	-			-	0.5	
56	Input Voltage Low Level (Noise Immunity) (Functional Test)	$V_{IL2}$	-	4(a)	$V_{IL} = 4.0\text{Vdc}$ $V_{IH} = 11\text{Vdc}$ $V_{DD} = 15\text{Vdc}, V_{SS} = 0\text{Vdc}$ Note 5 (Pins D/F 1-2-4-6-7-13) (Pins C 1-2-5-7-9-16)	13.5	-	V
	Input Voltage High Level (Noise Immunity) (Functional Test)	$V_{IH2}$	-			-	1.5	

**NOTES:** See Page 26.



**TABLE 3(b) - ELECTRICAL MEASUREMENTS AT LOW TEMPERATURE,  $-55(+5-0)^\circ\text{C}$  (CONT'D)**

No.	CHARACTERISTICS	SYMBOL	TEST METHOD MIL-STD 883	TEST FIG.	TEST CONDITIONS (PINS UNDER TEST D/F = DIP AND FP C = CCP)	LIMITS		UNIT
						MIN	MAX	
57	Bias Leakage Current (1)	$I_{LB1}$	-	4(j)	$V_{IN}$ (Comparator and VCO In) = 0Vdc $V_{IN}$ (Inhibit and R <sub>2</sub> ) = 15Vdc Signal In = Open $V_{DD}$ = 15Vdc, $V_{SS}$ = 0Vdc (Pin D/F 8) (Pin C 10)	-	-1.5	mA
58	Bias Leakage Current (2)	$I_{LB2}$	-	4(j)	$V_{IN}$ (Signal In) = 0Vdc $V_{IN}$ (Comparator and VCO In) = 0Vdc $V_{IN}$ (Inhibit and R <sub>2</sub> ) = 15Vdc $V_{DD}$ = 15Vdc, $V_{SS}$ = 0Vdc (Pin D/F 14) (Pin C 17)	-	-240	$\mu\text{A}$
59	Bias Leakage Current (3)	$I_{LB3}$	-	4(j)	$V_{IN}$ (Signal In) = 15Vdc $V_{IN}$ (Comparator and VCO In) = 0Vdc $V_{IN}$ (Inhibit and R <sub>2</sub> ) = 15Vdc $V_{DD}$ = 15Vdc, $V_{SS}$ = 0Vdc (Pin D/F 14) (Pin C 17)	-	240	$\mu\text{A}$
60	Threshold Voltage N-Channel	$V_{THN}$	-	4(k)	Comparator In, Inhibit, 1C1, 2C1, Signal In and $V_{SS}$ = -5V $V_{IN}$ (Remaining Inputs) = 0Vdc $I$ (Demod. Out) = -10 $\mu\text{A}$ $V_{DD}$ = 0Vdc (Pin D/F 10) (Pin C 12)	-0.7	-3.5	V
61	Threshold Voltage P-Channel	$V_{THP}$	-	4(l)	$V_{DD}$ at Ground. $I_{(R2)}$ = -10 $\mu\text{A}$ $V_{IN}$ (Remaining Inputs) = -5Vdc $V_{SS}$ = -5Vdc (Pin D/F 12) (Pin C 15)	-0.7	-3.5	V
62	Zener Voltage	$V_Z$	-	4(m)	$I_Z$ = 50 $\mu\text{A}$ (Pin D/F 15) (Pin C 19)	4.45	7.5	V

**NOTES:** See Page 26.



**FIGURE 4 - CIRCUITS FOR ELECTRICAL MEASUREMENTS**

**FIGURE 4(a) - FUNCTIONAL TEST TABLE**

PATTERN No.	PIN NUMBERS											D.C. SUPPLY	
	1	2	3	4	5	6	7	12	14	A	B	8	16
0	X	0	0	0	1	0	0	H	0	X	X	V <sub>SS</sub>	V <sub>DD</sub>
1	X	1	0	0	1	0	0	H	1	X	X		
2	X	0	0	0	1	0	0	H	0	X	X		
3	0	1	0	1	0	1	1	H	1	1	0		
4	0	0	0	0	0	0	1	H	0	1	0		
5	1	1	1	0	0	0	0	H	0	0	0		
6	0	0	1	1	0	1	0	H	1	1	0		
7	0	1	0	1	0	0	0	H	1	1	0		
8	X	X	0	X	1	0	0	H	1	X	X		
9	1	0	1	0	1	0	0	H	1	0	0		
10	1	1	1	0	1	0	1	H	0	0	0		
11	0	0	1	0	1	1	1	H	1	1	0		
12	0	1	1	0	1	1	0	H	0	1	0		
13	0	0	1	0	1	0	0	H	1	1	0		
14	0	1	1	0	1	0	0	H	0	1	0		
15	0	0	0	0	1	0	0	H	0	1	0		
16	0	1	0	0	1	0	0	H	1	1	0		
17	1	0	1	0	1	0	0	H	1	0	0		
18	1	1	0	0	1	0	0	H	1	0	0		
19	0	0	1	0	1	0	0	H	1	0	1		
20	0	1	0	0	1	0	0	H	1	0	1		
21	0	0	1	0	1	0	0	H	1	0	1		
22	0	1	0	0	1	0	0	H	1	0	1		
23	0	0	0	0	1	0	0	H	0	0	1		
24	0	1	1	0	1	0	0	H	0	0	1		
25	0	0	0	0	1	0	0	H	0	0	1		
26	1	1	0	0	1	0	0	H	1	0	0		
27	0	0	1	0	1	0	0	H	1	0	1		
28	0	1	1	0	1	0	0	H	0	0	1		
29	1	0	1	0	1	0	0	H	1	0	0		
30	1	1	0	0	1	0	0	H	1	0	0		
31	1	0	0	0	1	0	0	H	0	0	0		
32	0	1	1	0	1	0	0	H	0	0	1		
33	1	0	1	0	1	0	0	H	1	0	0		
34	1	1	1	0	1	0	0	H	0	0	0		
35	1	0	0	0	1	0	0	H	0	0	0		
36	0	1	0	0	1	0	0	H	1	1	0		

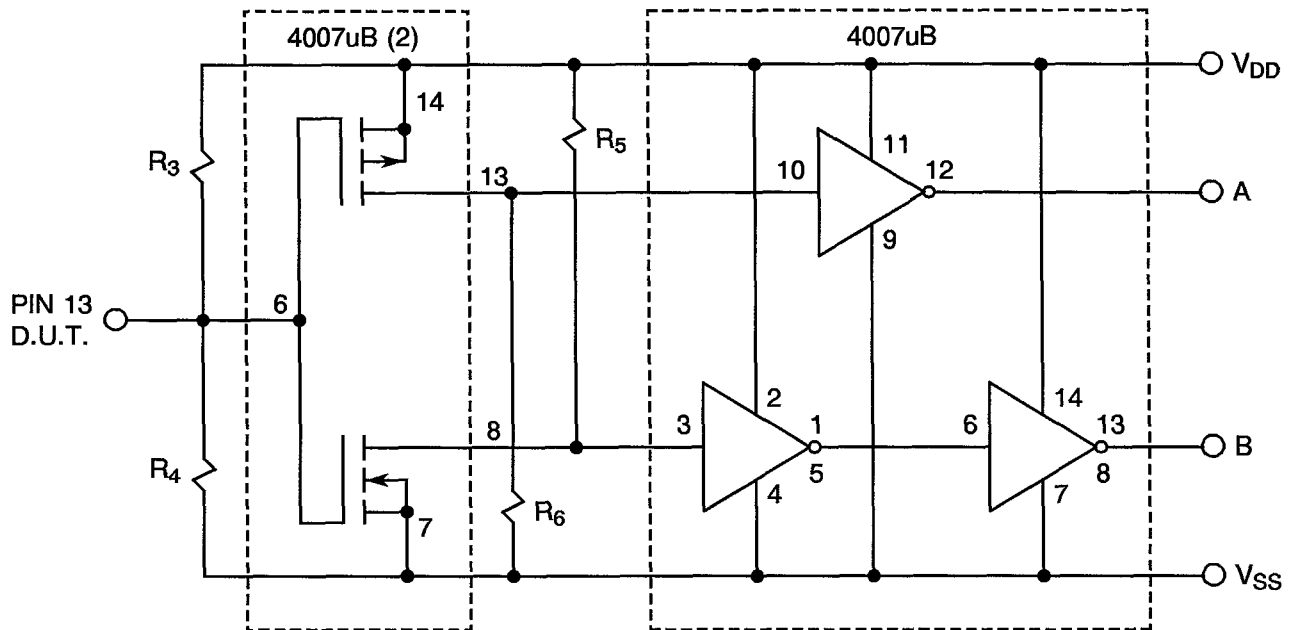
**NOTES:** See Page 36.



**FIGURE 4 - CIRCUITS FOR ELECTRICAL MEASUREMENTS (CONTINUED)**

NOTES TO FIGURE 4(a) - FUNCTIONAL TEST TABLE

1. Figure 4(a) illustrates one series of Test Patterns. Any other pattern series must be agreed with the Qualifying Space Agency and shall be included as an Appendix.
2. Logic Level Definitions: 1 =  $V_{IH} = V_{DD}$ , 0 =  $V_{IL} = V_{SS}$ , X = Don't Care, H = Connected to  $V_{DD}$ .
3. Diagram for the connection of 4007uB to 4046B for the formation of Outputs A and B.



**NOTES**

1.  $R_3 = R_4 = 10k\Omega$ .  
 $R_5 = R_6 = 200k\Omega$ .
2. Unused pins to be biased as follows:
  - Pins 2 and 11 =  $V_{DD}$ .
  - Pins 3, 4, 9, 10 =  $V_{SS}$ .
  - For the Low Voltage Functional Test,  $V_{DD}$  for external 4007uB's should be made higher to ensure correct operation.



**FIGURE 4 - CIRCUITS FOR ELECTRICAL MEASUREMENTS (CONTINUED)**

**FIGURE 4(b) - QUIESCENT CURRENT TEST TABLE**

PATTERN No.	PIN NUMBERS								I <sub>DD</sub> TEST	D.C. SUPPLY	
	INPUTS									8	16
	3	5	6	7	9	11	12	14			
0	1	1	0	0	0	0	0	0		V <sub>SS</sub>	V <sub>DD</sub>
1	1	1	0	0	0	0	0	1			
2	1	1	0	0	0	0	0	0	1		
3	1	1	0	0	0	0	0	1	1		
4	0	0	1	0	0	0	1	1			
5	0	0	0	0	0	0	1	1			
6	1	0	0	1	0	0	1	1			
7	1	0	0	0	0	0	1	1			
8	0	0	0	0	0	0	1	1			
9	1	0	0	0	0	0	1	1			
10	0	0	0	0	0	0	1	1			
11	1	1	-	-	0	0	1	0			
12	1	1	-	-	0	0	1	1			
13	1	1	-	-	0	0	1	0			
14	1	1	-	-	0	0	1	1			
15	1	1	-	-	0	0	1	0			
16	0	1	-	-	0	0	1	0			
17	1	1	-	-	0	0	1	0			
18	0	1	-	-	0	0	1	0			
19	1	1	-	-	0	0	1	0			
20	0	1	-	-	0	0	1	0			

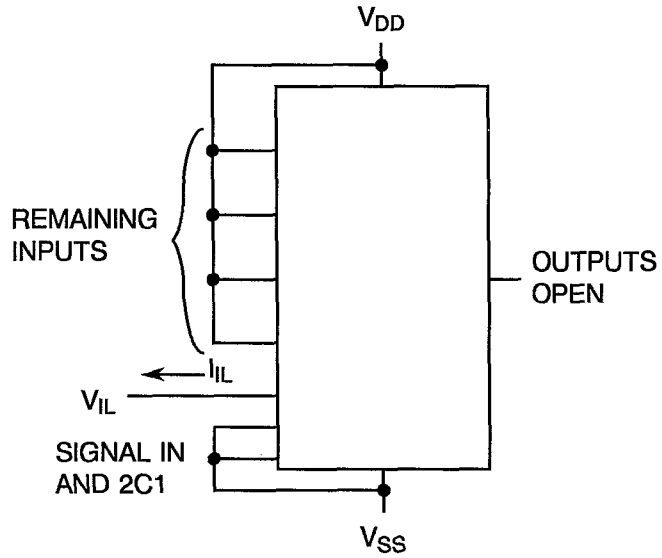
**NOTES**

- Figure 4(b) illustrates one series of Test Patterns. Any other pattern series must be agreed with the Qualifying Space Agency and shall be included as an Appendix.
- 1 = V<sub>IH</sub> = V<sub>DD</sub>, 0 = V<sub>IL</sub> = V<sub>SS</sub>.
- I<sub>DD</sub> Test No. 1-6 performed with M.S. in the V<sub>DD</sub> line, use positive (+) leakage limits.  
I<sub>DD</sub> Test No. 7-12 performed with M.S. in the V<sub>SS</sub> line, use negative (-) leakage limits.
- The leakage tests are performed in two sequences:-  
The first 6 leakage tests are done with the M.S. in the V<sub>DD</sub> (Pin D/F 16) line and the V<sub>SS</sub> pin (D/F 8) tied on GND.  
The second 6 leakage tests are done with M.S. in the V<sub>SS</sub> line (Pin D/F 8) and the V<sub>DD</sub> pin (Pin D/F 16) tied to V<sub>DD</sub>.



**FIGURE 4 - CIRCUITS FOR ELECTRICAL MEASUREMENTS (CONTINUED)**

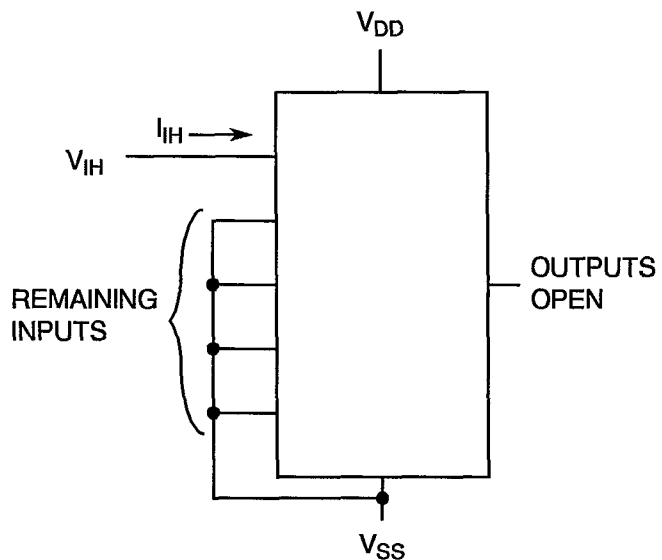
**FIGURE 4(c) - LOW LEVEL INPUT CURRENT**



**NOTES**

1. Each input to be tested separately.

**FIGURE 4(d) - HIGH LEVEL INPUT CURRENT**



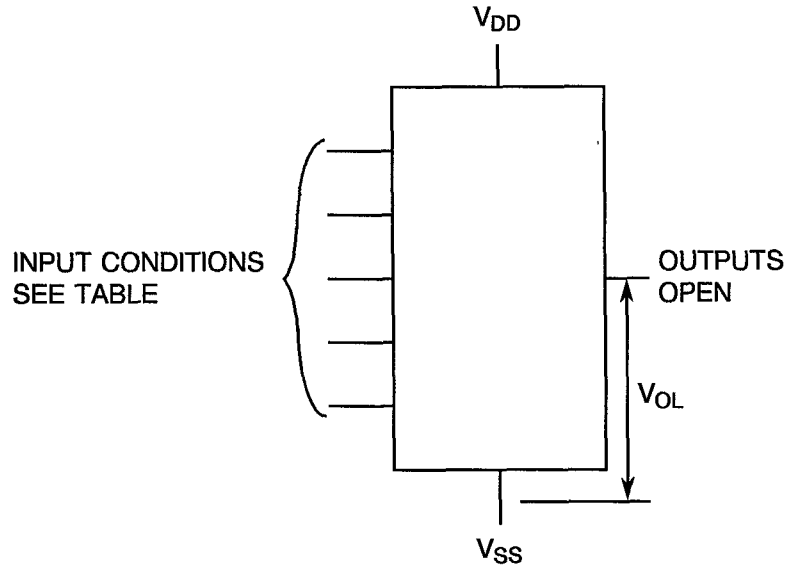
**NOTES**

1. Each input to be tested separately.



**FIGURE 4 - CIRCUITS FOR ELECTRICAL MEASUREMENTS (CONTINUED)**

FIGURE 4(e) - LOW LEVEL OUTPUT VOLTAGE



**NOTES**

1. Each output to be tested separately.

TABLE 4(e)

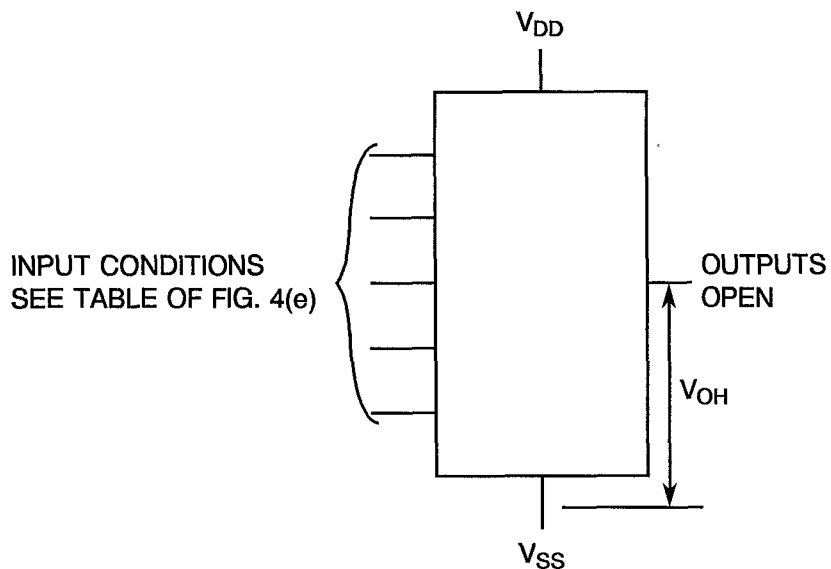
PATTERN No.	PIN NUMBERS			TEST	D.C. SUPPLY	
	INPUTS				8	16
	3	6	14		0	V <sub>DD</sub>
0	0	-	1	1	↓	↓
1	1	-	1			
2	0	-	1			
3	1	-	1			
4	1	-	1			
5	1	0	0	2	↓	↓
6	1	1	1			
7	1	0	0			
8	1	0	1			
9	1	0	0			
10	0	0	0			
11	1	0	0	3		

**NOTES**

1. 1 = V<sub>IH</sub> = V<sub>DD</sub>, 0 = V<sub>IL</sub> = V<sub>SS</sub>.
2. Test 1 : V<sub>OL</sub> - I<sub>OL</sub> all pins.  
Test 2 : V<sub>OH</sub> - I<sub>OH</sub> (Pins D/F 2-4-13), (Pins C 2-5-16).  
Test 3 : V<sub>OH</sub> - I<sub>OH</sub> (Pin D/F 1), (Pin C 1).

**FIGURE 4 - CIRCUITS FOR ELECTRICAL MEASUREMENTS (CONTINUED)**

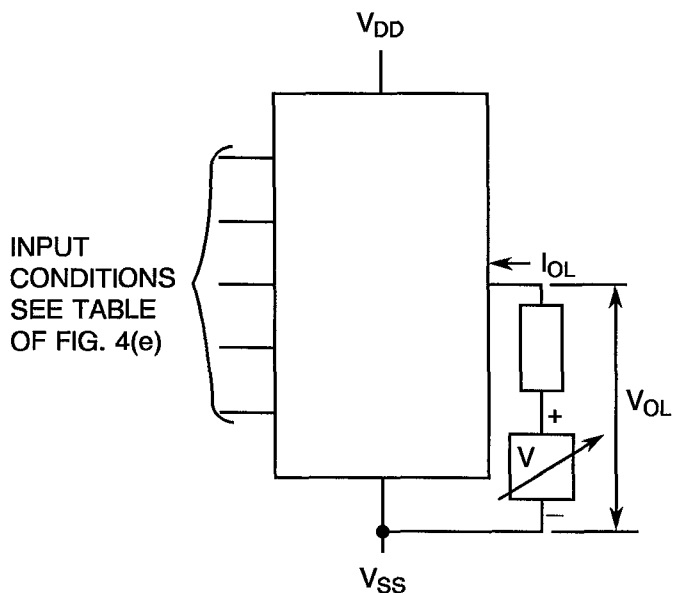
FIGURE 4(f) - HIGH LEVEL OUTPUT VOLTAGE



**NOTES**

1. Each output to be tested separately.

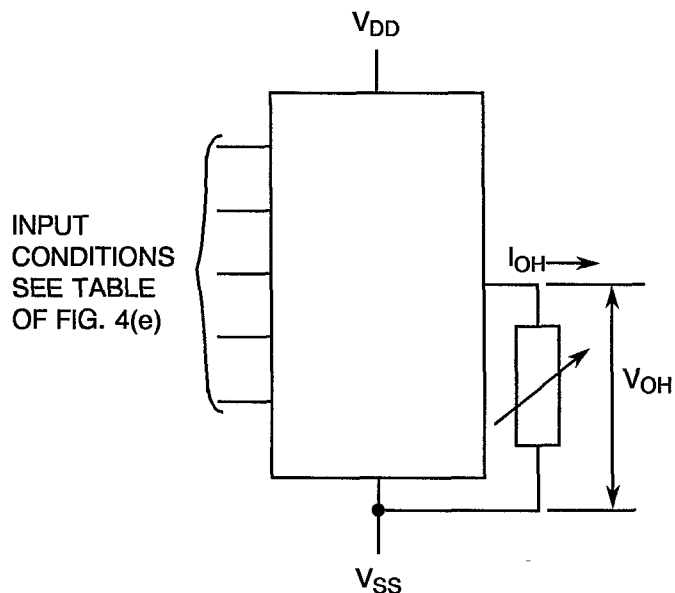
FIGURE 4(g) - LOW LEVEL OUTPUT CURRENT



**NOTES**

1. Each output to be tested separately.

FIGURE 4(h) - HIGH LEVEL OUTPUT CURRENT



**NOTES**

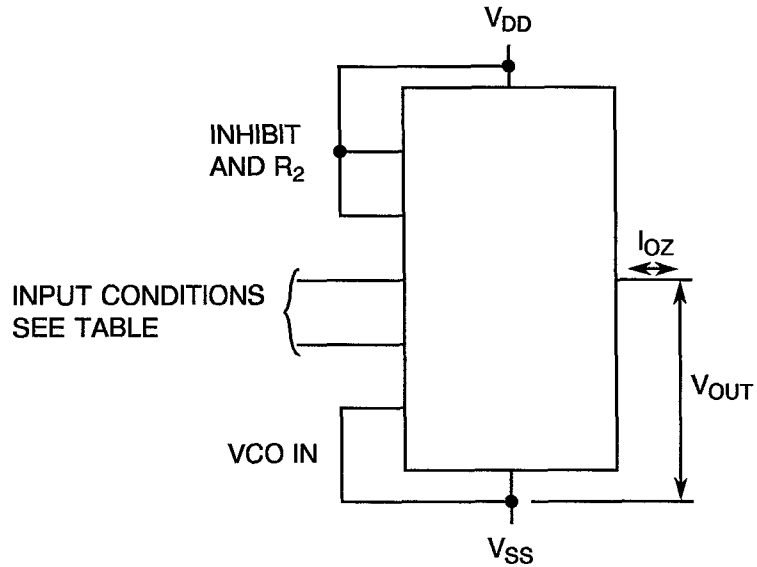
1. Each output to be tested separately.





**FIGURE 4 - CIRCUITS FOR ELECTRICAL MEASUREMENTS (CONTINUED)**

**FIGURE 4(i) - OUTPUT LEAKAGE CURRENT THIRD STATE**



**TABLE 4(i)**

PATTERN NO.	PIN NUMBERS		TEST
	INPUTS		
	3	14	
0	0	0	
1	1	0	
2	0	0	
3	1	0	
4	0	1	X

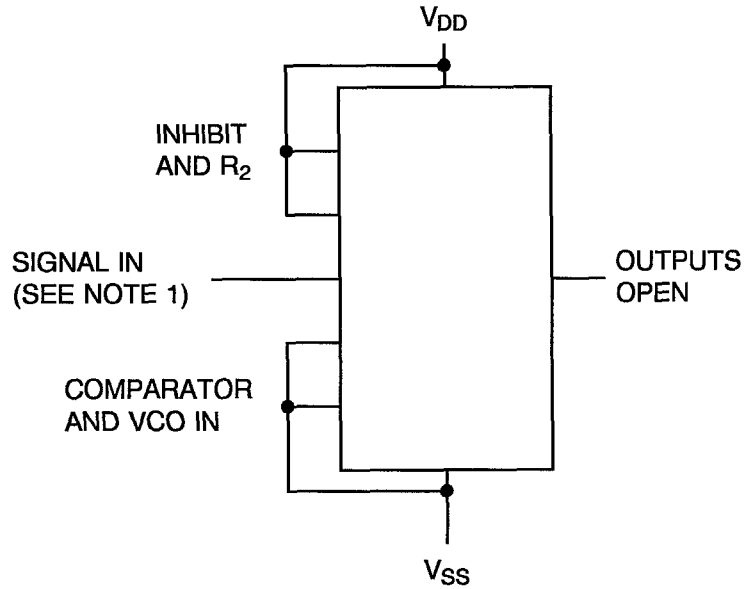
**NOTES**

- Logic Level Definitions: "0" =  $V_{SS}$ , "1" =  $V_{DD}$ .



**FIGURE 4 - CIRCUITS FOR ELECTRICAL MEASUREMENTS (CONTINUED)**

FIGURE 4(j) - BIAS LEAKAGE CURRENT



**NOTES**

1. For Input Conditions see Table 2.
2.  $I_{LB1}$  measured at Pin 8.
3.  $I_{LB2}$  and  $I_{LB3}$  measured at Pin 14.

FIGURE 4(k) - THRESHOLD VOLTAGE N-CHANNEL

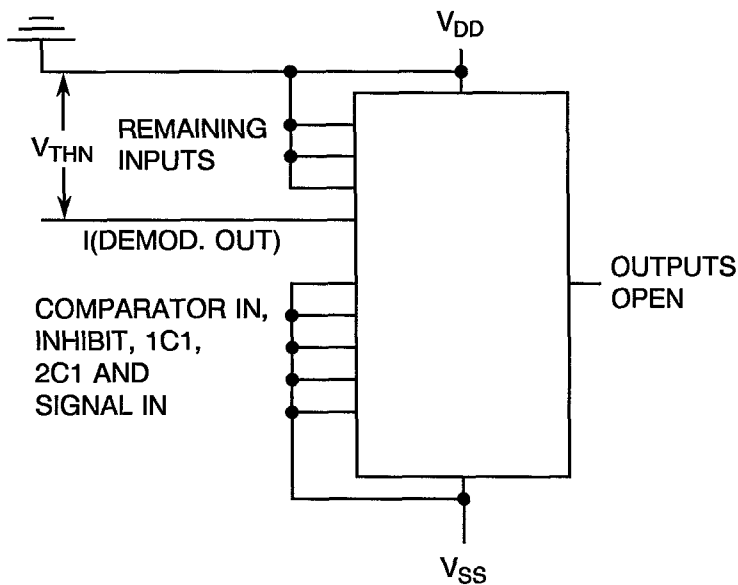
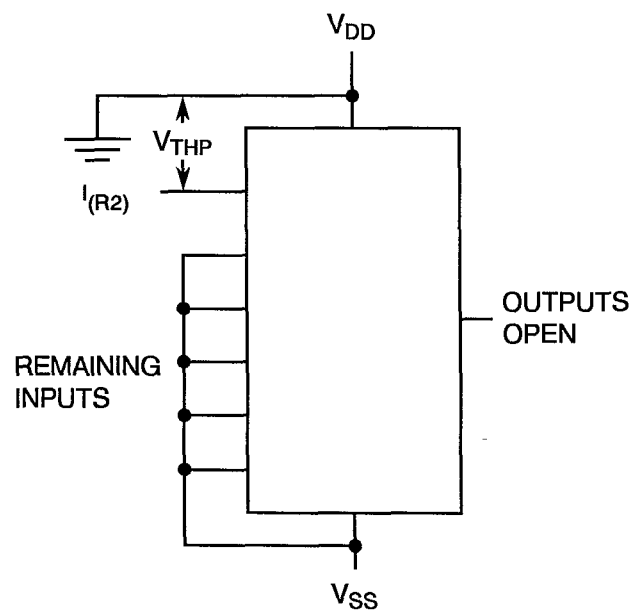


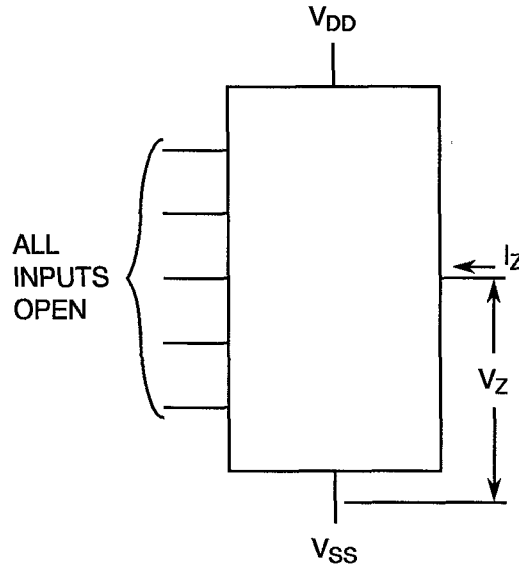
FIGURE 4(l) - THRESHOLD VOLTAGE P-CHANNEL



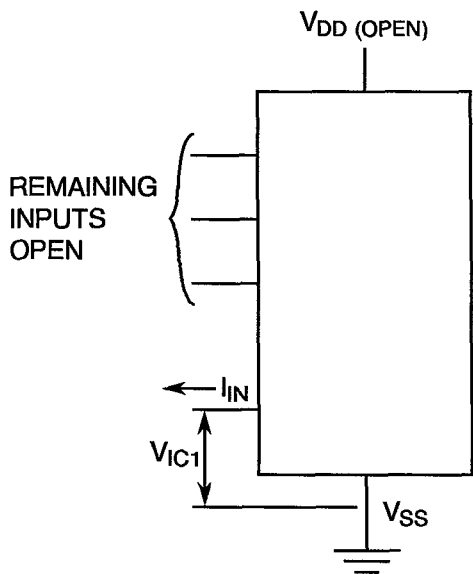


**FIGURE 4 - CIRCUITS FOR ELECTRICAL MEASUREMENTS (CONTINUED)**

**FIGURE 4(m) - ZENER VOLTAGE**



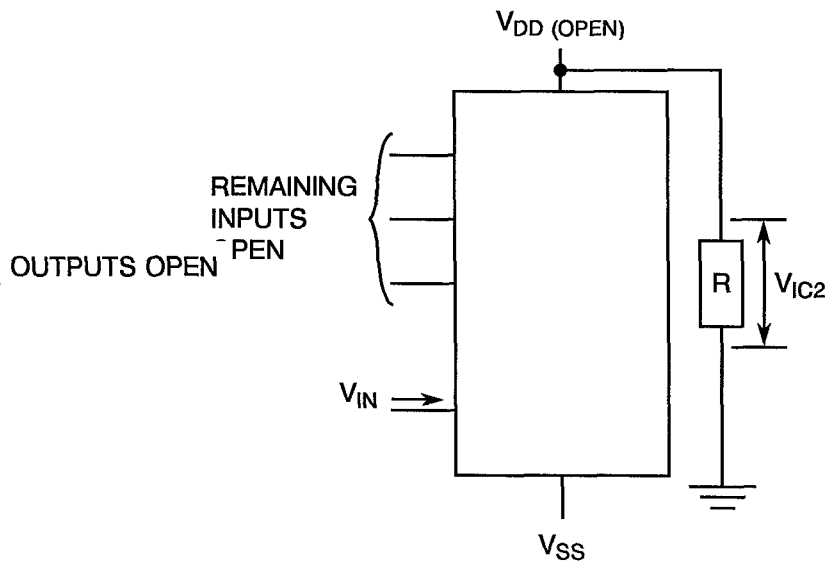
**FIGURE 4(n) - INPUT CLAMP VOLTAGE ( $V_{SS}$ )**



**NOTES**

1. Each input to be tested separately.

**FIGURE 4(o) - INPUT CLAMP VOLTAGE ( $V_{DD}$ )**



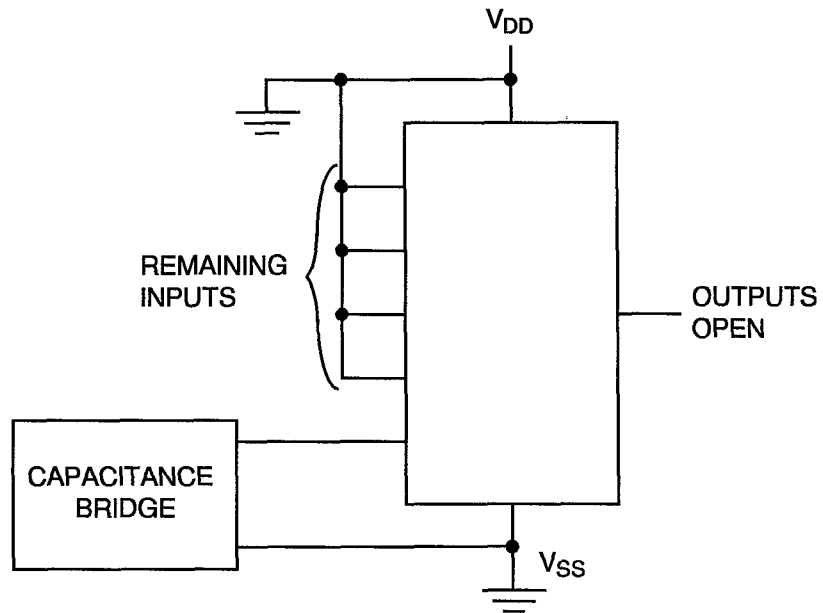
**NOTES**

1. Each input to be tested separately.



**FIGURE 4 - CIRCUITS FOR ELECTRICAL MEASUREMENTS (CONTINUED)**

**FIGURE 4(p) - INPUT CAPACITANCE**



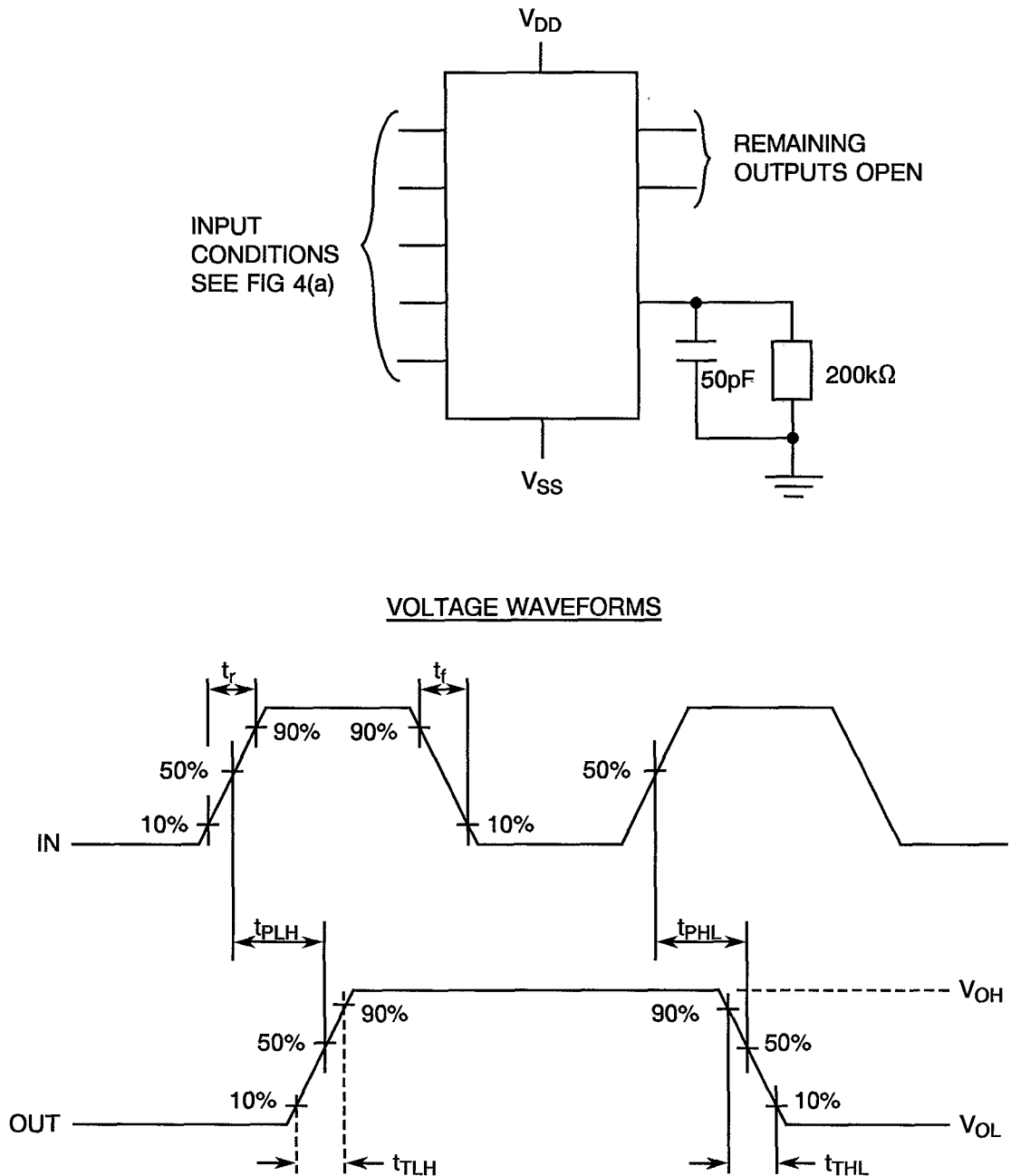
**NOTES**

1. Each input to be tested separately.
2.  $f = 100\text{kHz}$  to  $1\text{MHz}$ .



**FIGURE 4 - CIRCUITS FOR ELECTRICAL MEASUREMENTS (CONTINUED)**

**FIGURE 4(g) - PROPAGATION DELAY AND TRANSITION TIME**



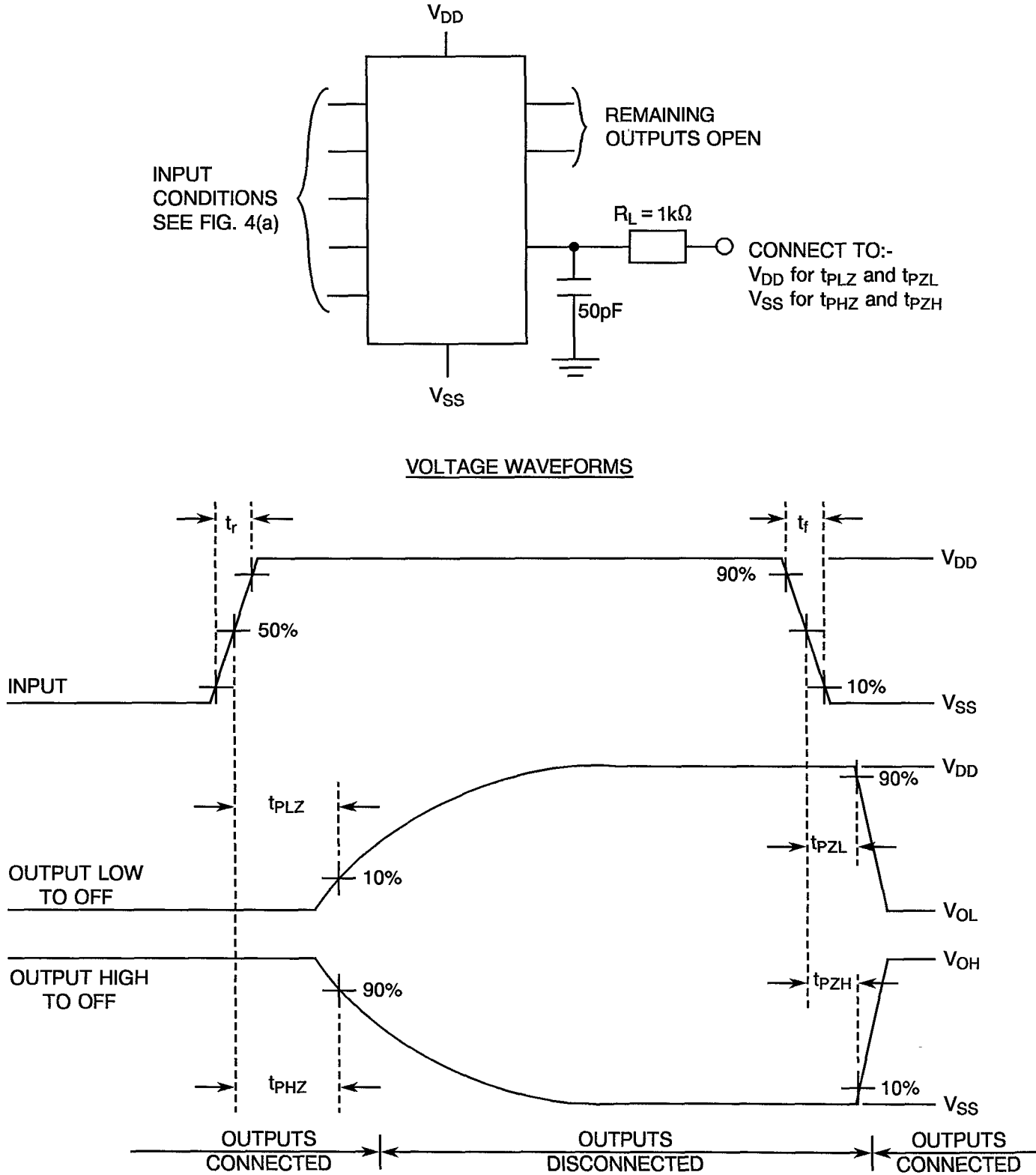
**NOTES**

1. Pulse Generator -  $V_p = 0$  to  $V_{DD}$ ,  $t_r$  and  $t_f \leq 20\text{ns}$ ,  $f = 500\text{kHz}$ .



**FIGURE 4 - CIRCUITS FOR ELECTRICAL MEASUREMENTS (CONTINUED)**

**FIGURE 4(r) - PROPAGATION DELAY INPUT TO PHASE COMPARATOR II OUTPUT**



**NOTES**

1. Pulse Generator -  $V_p = 0$  to  $V_{DD}$ ,  $t_r$  and  $t_f \leq 20ns$ ,  $f = 500kHz$ .

**TABLE 4 - PARAMETER DRIFT VALUES**

No.	CHARACTERISTICS	SYMBOL	SPEC. AND/OR TEST METHOD	TEST CONDITIONS	CHANGE LIMITS ( $\Delta$ )	UNIT
3 to 14	Quiescent Current	$I_{DD}$	As per Table 2	As per Table 2	$\pm 12$	$\mu A$
33 to 38	Output Drive Current N-Channel	$I_{OL1}$	As per Table 2	As per Table 2	$\pm 15$ (1)	%
45 to 48	Output Drive Current P-Channel	$I_{OH1}$	As per Table 2	As per Table 2	$\pm 15$ (1)	%
53	Output Leakage Current Third State (1)	$I_{OZ1}$	As per Table 2	As per Table 2	$\pm 60$	nA
54	Output Leakage Current Third State (2)	$I_{OZ2}$	As per Table 2	As per Table 2	$\pm 60$	nA
60	Threshold Voltage N-Channel	$V_{THN}$	As per Table 2	As per Table 2	$\pm 0.3$	V
61	Threshold Voltage P-Channel	$V_{THP}$	As per Table 2	As per Table 2	$\pm 0.3$	V

**NOTES**

1. Percentage of limit value if voltage is the measurement function.

**TABLE 5(a) - CONDITIONS FOR BURN-IN HIGH TEMPERATURE REVERSE BIAS, N-CHANNELS**

No.	CHARACTERISTICS	SYMBOL	CONDITION	UNIT
1	Ambient Temperature	$T_{amb}$	+ 125 (+ 0 – 5)	°C
2	Outputs - (Pins D/F 1-2-4-10-13-15) (Pins C 1-2-5-12-16-19)	$V_{OUT}$	Open	-
3	Inputs - (Pins D/F 11-12) (Pins C 14-15)	$V_{IN}$	Ground	Vdc
4	Inputs - (Pins D/F 3-5-9-14) (Pins C 4-6-11-17)	$V_{IN}$	Ground	Vdc
5	Positive Supply Voltage (Pin D/F 16) (Pin C 20)	$V_{DD}$	15	Vdc
6	Negative Supply Voltage (Pin D/F 8) (Pin C 10)	$V_{SS}$	Ground	Vdc

**NOTES**

1. Input Load = Protection Resistor = 2k $\Omega$  minimum to 47k $\Omega$  maximum.

**TABLE 5(b) - CONDITIONS FOR BURN-IN HIGH TEMPERATURE REVERSE BIAS, P-CHANNELS**

No.	CHARACTERISTICS	SYMBOL	CONDITION	UNIT
1	Ambient Temperature	$T_{amb}$	+ 125 (+ 0 – 5)	°C
2	Outputs - (Pins D/F 1-2-4-10-13-15) (Pins C 1-2-5-12-16-19)	$V_{OUT}$	Open	-
3	Inputs - (Pins D/F 11-12) (Pins C 14-15)	$V_{IN}$	Ground	Vdc
4	Inputs - (Pins D/F 3-5-9-14) (Pins C 4-6-11-17)	$V_{IN}$	$V_{DD}$	Vdc
5	Positive Supply Voltage (Pin D/F 16) (Pin C 20)	$V_{DD}$	15	Vdc
6	Negative Supply Voltage (Pin D/F 8) (Pin C 10)	$V_{SS}$	Ground	Vdc

**NOTES**

1. Input Load = Protection Resistor = 2k $\Omega$  minimum to 47k $\Omega$  maximum.



**TABLE 5(c) - CONDITIONS FOR BURN-IN DYNAMIC**

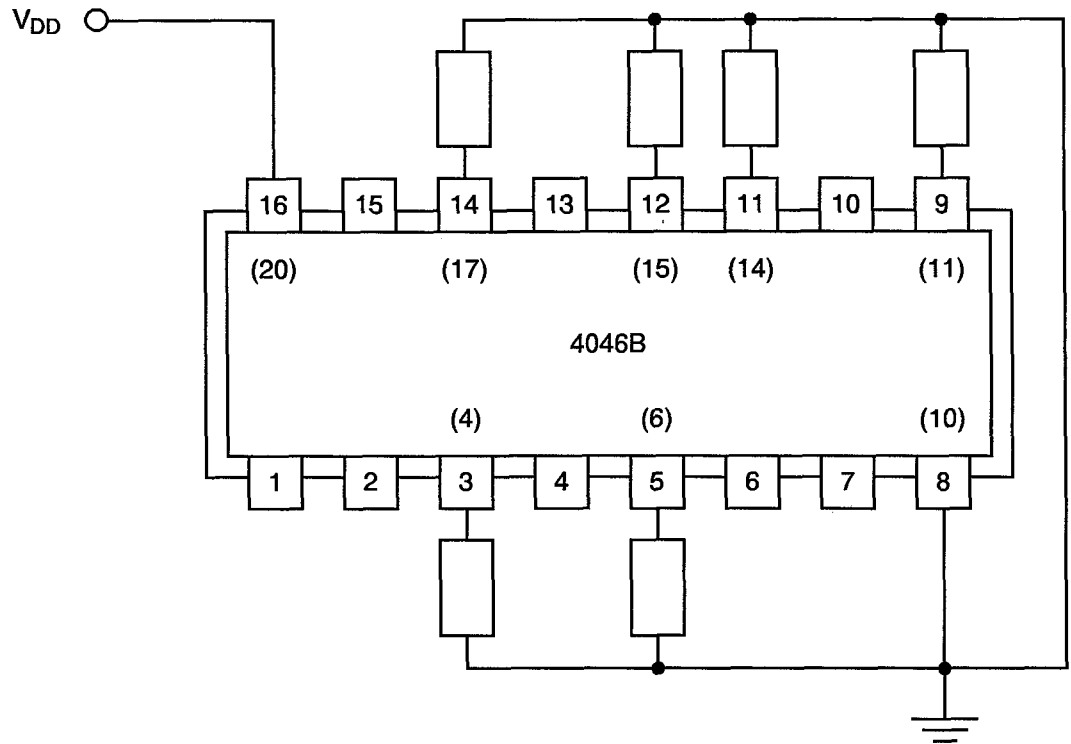
No.	CHARACTERISTICS	SYMBOL	CONDITIONS	UNIT
1	Ambient Temperature	$T_{amb}$	+ 125 (+ 0 – 5)	°C
2	Outputs - (Pins D/F 1-4-10-13-15) (Pins C 1-5-12-16-19)	$V_{OUT}$	$V_{DD/2}$	Vdc
3	Output - (Pin D/F 2) (Pin C 2)	$V_{OUT}$	+ 6.25	Vdc
4	Input - (Pin D/F 14) (Pin C 17)	$V_{IN}$	$V_{GEN}$	Vac
5	Input - (Pin D/F 9) (Pin C 11)	$V_{IN}$	Ground	Vdc
6	Inputs - (Pins D/F 3-5-12) (Pins C 4-6-15)	$V_{IN}$	$V_{DD}$	Vdc
7	Input - (Pin D/F 11) (Pin C 14)	$V_{IN}$	Open	-
8	Pulse Voltage	$V_{GEN}$	0 to $V_{DD}$	Vac
9	Pulse Frequency Square Wave	f	50k, 50% Duty Cycle	Hz
10	Positive Supply Voltage (Pin D/F 16) (Pin C 20)	$V_{DD}$	15	Vdc
11	Negative Supply Voltage (Pin D/F 8) (Pin C 10)	$V_{SS}$	Ground	Vdc

**NOTES**

1. Input Load = Output Load = 2k $\Omega$  minimum to 47k $\Omega$  maximum.



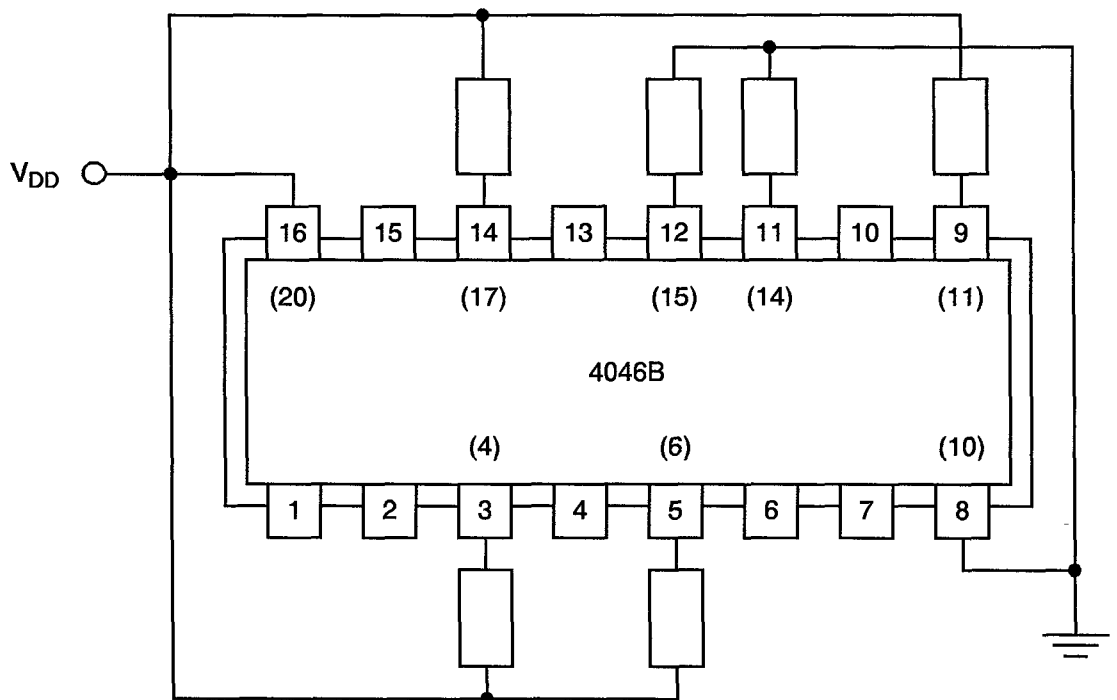
**FIGURE 5(a) - ELECTRICAL CIRCUIT FOR BURN-IN HIGH TEMPERATURE REVERSE BIAS, N-CHANNELS**



**NOTES**

1. Pin numbers in parenthesis are for the chip carrier package.

**FIGURE 5(b) - ELECTRICAL CIRCUIT FOR BURN-IN HIGH TEMPERATURE REVERSE BIAS, P-CHANNELS**

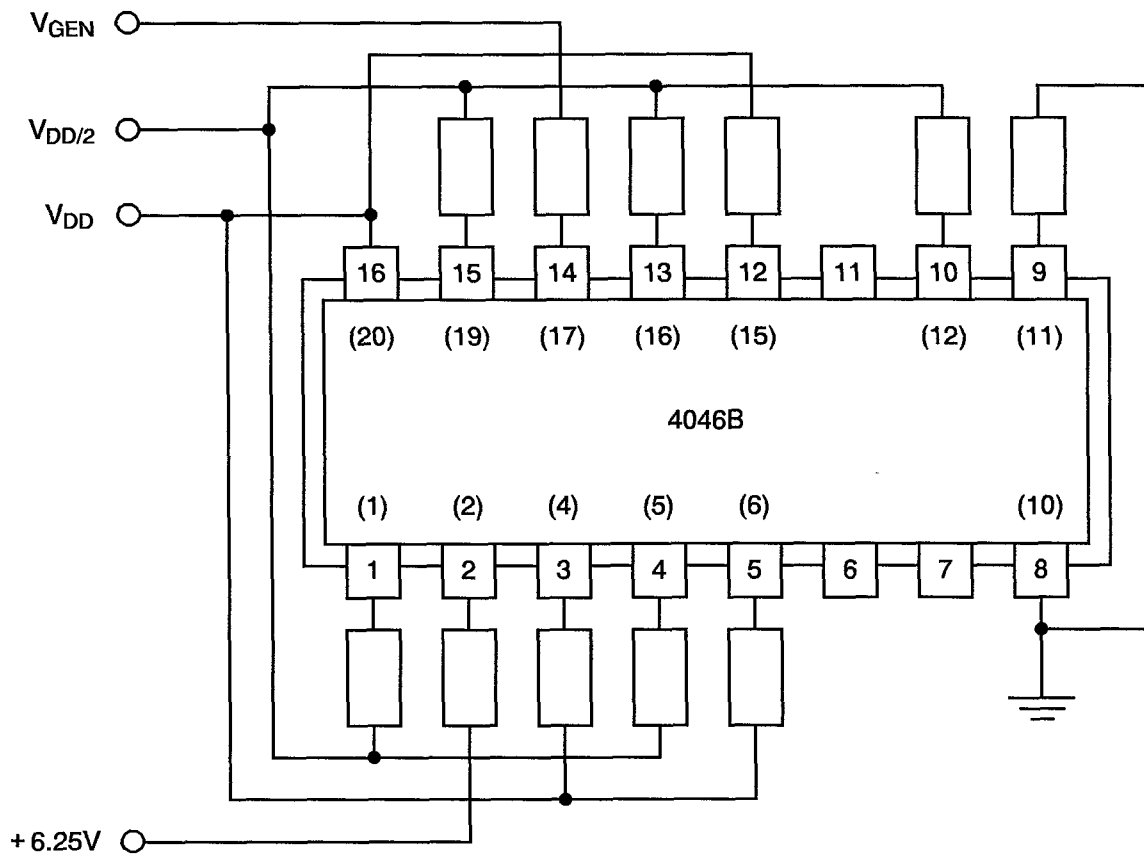


**NOTES**

1. Pin numbers in parenthesis are for the chip carrier package.



**FIGURE 5(c) - ELECTRICAL CIRCUIT FOR BURN-IN DYNAMIC**



**NOTES**

1. Pin numbers in parenthesis are for the chip carrier package.



4.8 ENVIRONMENTAL AND ENDURANCE TESTS (CHARTS IV AND V OF ESA/SCC GENERIC SPECIFICATION NO. 9000)

4.8.1 Electrical Measurements on Completion of Environmental Tests

The parameters to be measured on completion of environmental tests are scheduled in Table 6. Unless otherwise stated, the measurements shall be performed at  $T_{amb} = +22 \pm 3$  °C.

4.8.2 Electrical Measurements at Intermediate Points during Endurance Tests

The parameters to be measured at intermediate points during endurance tests are as scheduled in Table 6 of this specification. Unless otherwise stated, the measurements shall be performed at  $T_{amb} = +22 \pm 3$  °C.

4.8.3 Electrical Measurements on Completion of Endurance Tests

The parameters to be measured on completion of endurance testing are as scheduled in Table 6 of this specification. Unless otherwise stated, the measurements shall be performed at  $T_{amb} = +22 \pm 3$  °C.

4.8.4 Conditions for Operating Life Test

The requirements for operating life testing are specified in Section 9 of ESA/SCC Generic Specification No. 9000. The conditions for operating life testing shall be as specified in Table 5(c) of this specification.

4.8.5 Electrical Circuits for Operating Life Tests

Circuits for use in performing the operating life tests are shown in Figure 5(c) of this specification.

4.8.6 Conditions for High Temperature Storage Test

The requirements for the high temperature storage test are specified in ESA/SCC Generic Specification No. 9000. The temperature to be applied shall be the maximum storage temperature specified in Table 1(b) of this specification.

**TABLE 6 - ELECTRICAL MEASUREMENTS ON COMPLETION OF ENVIRONMENTAL TESTS AND AT INTERMEDIATE POINTS AND ON COMPLETION OF ENDURANCE TESTING**

No.	CHARACTERISTICS	SYMBOL	SPEC. AND/OR TEST METHOD	TEST CONDITIONS	CHANGE LIMITS ( $\Delta$ )			UNIT
						MIN	MAX	
1	Functional Test	-	As per Table 2	As per Table 2	-	-	-	-
3 to 14	Quiescent Current	$I_{DD}$	As per Table 2	As per Table 2	$\pm 12$	-	-	$\mu A$
15 to 18	Input Current Low Level	$I_{IL}$	As per Table 2	As per Table 2	-	-	-0.1	$\mu A$
19 to 22	Input Current High Level	$I_{IH}$	As per Table 2	As per Table 2	-	-	0.1	$\mu A$
23 to 28	Output Voltage Low Level	$V_{OL}$	As per Table 2	As per Table 2	-	-	0.05	V
29 to 32	Output Voltage High Level	$V_{OH}$	As per Table 2	As per Table 2	-	14.95	-	V
33 to 38	Output Drive Current N-Channel	$I_{OL1}$	As per Table 2	As per Table 2	$\pm 15$ (1)	-	-	%
39 to 44	Output Drive Current N-Channel	$I_{OL2}$	As per Table 2	As per Table 2	$\pm 15$ (1)	-	-	%
45 to 48	Output Drive Current P-Channel	$I_{OH1}$	As per Table 2	As per Table 2	$\pm 15$ (1)	-	-	%
49 to 52	Output Drive Current P-Channel	$I_{OH2}$	As per Table 2	As per Table 2	$\pm 15$ (1)	-	-	%
53	Output Leakage Current Third State (1)	$I_{OZ1}$	As per Table 2	As per Table 2	$\pm 60$	-	-	nA
54	Output Leakage Current Third State (2)	$I_{OZ2}$	As per Table 2	As per Table 2	$\pm 60$	-	-	nA

**NOTES**

1. Percentage of limit value if voltage is the measurement function.

**TABLE 6 - ELECTRICAL MEASUREMENTS ON COMPLETION OF ENVIRONMENTAL TESTS AND AT INTERMEDIATE POINTS AND ON COMPLETION OF ENDURANCE TESTING (CONT'D)**

No.	CHARACTERISTICS	SYMBOL	SPEC. AND/OR TEST METHOD	TEST CONDITIONS	CHANGE LIMITS ( $\Delta$ )			UNIT
						MIN	MAX	
55	Input Voltage Low Level (Noise Immunity) (Functional Test)	$V_{IL1}$	As per Table 2	As per Table 2	-	4.5	-	V
	Input Voltage High Level (Noise Immunity) (Functional Test)	$V_{IH1}$			-	-	0.5	
57	Bias Leakage Current (1)	$I_{LB1}$	As per Table 2	As per Table 2	-	-	-1.5	mA
58	Bias Leakage Current (2)	$I_{LB2}$	As per Table 2	As per Table 2	-	-	-150	$\mu$ A
59	Bias Leakage Current (3)	$I_{LB3}$	As per Table 2	As per Table 2	-	-	150	$\mu$ A
60	Threshold Voltage N-Channel	$V_{THN}$	As per Table 2	As per Table 2	$\pm 0.3$	-	-	V
61	Threshold Voltage P-Channel	$V_{THP}$	As per Table 2	As per Table 2	$\pm 0.3$	-	-	V
62	Zener Voltage	$V_Z$	As per Table 2	As per Table 2	-	4.45	7.5	V



APPENDIX 'A'

AGREED DEVIATIONS FOR STMICROELECTRONICS (F)

ITEMS AFFECTED	DESCRIPTION OF DEVIATION
Para. 4.2.3	Para. 9.23, High Temperature Reverse Bias Burn-in: The temperature limits of MIL-STD-883, Para. 4.5.8(c) may be used.  Para. 9.24, Power Burn-in: The temperature limits of MIL-STD-883, Para. 4.5.8(c) may be used.
Para. 4.2.4	Para. 9.21.1, Operating Life during Qualification Testing: The temperature limits of MIL-STD-883, Para. 4.5.8(c) may be used.
Para. 4.2.5	Para. 9.21.2, Operating Life during Lot Acceptance Testing: The temperature limits of MIL-STD-883, Para. 4.5.8(c) may be used.