



europaean space agency  
agence spatiale européenne

Pages 1 to 28



**INTEGRATED CIRCUITS, SILICON MONOLITHIC,  
LOW POWER BIPOLAR SCHOTTKY DUAL  
J-K FLIP-FLOP WITH CLEAR,  
BASED ON TYPE 54LS73A  
ESA/SCC Detail Specification No. 9203/014**



**space components  
coordination group**

| Issue/Rev.   | Date         | Approved by   |                                       |
|--------------|--------------|---------------|---------------------------------------|
|              |              | SCCG Chairman | ESA Director General<br>or his Deputy |
| Issue 5      | July 1992    | <i>Pommes</i> | <i>[Signature]</i>                    |
| Revision 'A' | January 1995 | <i>Pommes</i> | <i>[Signature]</i>                    |
|              |              |               |                                       |
|              |              |               |                                       |



|                                                                                                                                                                    |                                                                                  |                           |
|--------------------------------------------------------------------------------------------------------------------------------------------------------------------|----------------------------------------------------------------------------------|---------------------------|
|   | <p style="text-align: center;">ESA/SCC Detail Specification<br/>No. 9203/014</p> | <p>PAGE 3<br/>ISSUE 5</p> |
|--------------------------------------------------------------------------------------------------------------------------------------------------------------------|----------------------------------------------------------------------------------|---------------------------|

## TABLE OF CONTENTS

|           |                                                                       | <u>Page</u> |
|-----------|-----------------------------------------------------------------------|-------------|
| <b>1.</b> | <b><u>GENERAL</u></b>                                                 | <b>5</b>    |
| 1.1       | Scope                                                                 | 5           |
| 1.2       | Component Type Variants                                               | 5           |
| 1.3       | Maximum Ratings                                                       | 5           |
| 1.4       | Parameter Derating Information                                        | 5           |
| 1.5       | Physical Dimensions                                                   | 5           |
| 1.6       | Pin Assignment                                                        | 5           |
| 1.7       | Truth Table                                                           | 5           |
| 1.8       | Circuit Schematic                                                     | 5           |
| 1.9       | Functional Diagram                                                    | 5           |
| <b>2.</b> | <b><u>APPLICABLE DOCUMENTS</u></b>                                    | <b>15</b>   |
| <b>3.</b> | <b><u>TERMS, DEFINITIONS, ABBREVIATIONS, SYMBOLS AND UNITS</u></b>    | <b>15</b>   |
| <b>4.</b> | <b><u>REQUIREMENTS</u></b>                                            | <b>15</b>   |
| 4.1       | General                                                               | 15          |
| 4.2       | Deviations from Generic Specification                                 | 15          |
| 4.2.1     | Deviations from Special In-process Controls                           | 15          |
| 4.2.2     | Deviations from Final Production Tests                                | 15          |
| 4.2.3     | Deviations from Burn-in Tests                                         | 15          |
| 4.2.4     | Deviations from Qualification Tests                                   | 15          |
| 4.2.5     | Deviations from Lot Acceptance Tests                                  | 15          |
| 4.3       | Mechanical Requirements                                               | 16          |
| 4.3.1     | Dimension Check                                                       | 16          |
| 4.3.2     | Weight                                                                | 16          |
| 4.4       | Materials and Finishes                                                | 16          |
| 4.4.1     | Case                                                                  | 16          |
| 4.4.2     | Lead Material and Finish                                              | 16          |
| 4.5       | Marking                                                               | 16          |
| 4.5.1     | General                                                               | 16          |
| 4.5.2     | Lead Identification                                                   | 16          |
| 4.5.3     | The SCC Component Number                                              | 16          |
| 4.5.4     | Traceability Information                                              | 17          |
| 4.6       | Electrical Measurements                                               | 17          |
| 4.6.1     | Electrical Measurements at Room Temperature                           | 17          |
| 4.6.2     | Electrical Measurements at High and Low Temperatures                  | 17          |
| 4.6.3     | Circuits for Electrical Measurements                                  | 17          |
| 4.7       | Burn-in Tests                                                         | 17          |
| 4.7.1     | Parameter Drift Values                                                | 17          |
| 4.7.2     | Conditions for Power Burn-in                                          | 17          |
| 4.7.3     | Electrical Circuits for Power Burn-in                                 | 17          |
| 4.8       | Environmental and Endurance Tests                                     | 26          |
| 4.8.1     | Electrical Measurements on Completion of Environmental Tests          | 26          |
| 4.8.2     | Electrical Measurements at Intermediate Points during Endurance Tests | 26          |
| 4.8.3     | Electrical Measurements on Completion of Endurance Tests              | 26          |
| 4.8.4     | Conditions for Operating Life Tests                                   | 26          |
| 4.8.5     | Electrical Circuits for Operating Life Tests                          | 26          |
| 4.8.6     | Conditions for High Temperature Storage Test                          | 26          |



**TABLES**

Page

|      |                                                                                                                              |    |
|------|------------------------------------------------------------------------------------------------------------------------------|----|
| 1(a) | Type Variants                                                                                                                | 6  |
| 1(b) | Maximum Ratings                                                                                                              | 6  |
| 2    | Electrical Measurements at Room Temperature, D.C. Parameters                                                                 | 18 |
|      | Electrical Measurements at Room Temperature, A.C. Parameters                                                                 | 19 |
| 3    | Electrical Measurements at High and Low Temperatures                                                                         | 20 |
| 4    | Parameter Drift Values                                                                                                       | 24 |
| 5    | Conditions for Power Burn-in and Operating Life Test                                                                         | 24 |
| 6    | Electrical Measurements on Completion of Environmental Tests and at Intermediate Points and on Completion of Endurance Tests | 27 |

**FIGURES**

|      |                                                              |     |
|------|--------------------------------------------------------------|-----|
| 1    | Not applicable                                               | N/A |
| 2    | Physical Dimensions                                          | 7   |
| 3(a) | Pin Assignment                                               | 12  |
| 3(b) | Truth Table                                                  | 13  |
| 3(c) | Circuit Schematic                                            | 14  |
| 3(d) | Functional Diagram                                           | 14  |
| 4    | Circuits for Electrical Measurements                         | 21  |
| 5    | Electrical Circuit for Power Burn-in and Operating Life Test | 25  |

**APPENDICES (Applicable to specific Manufacturers only)**

|     |                                             |    |
|-----|---------------------------------------------|----|
| 'A' | Agreed Deviations for Texas Instruments (F) | 28 |
|-----|---------------------------------------------|----|

**1. GENERAL****1.1 SCOPE**

This specification details the ratings, physical and electrical characteristics, test and inspection data for a Silicon Monolithic, Low Power Bipolar Schottky Dual J-K Flip-Flop with Clear, based on Type 54LS73A. It shall be read in conjunction with ESA/SCC Generic Specification No. 9000, the requirements of which are supplemented herein.

**1.2 COMPONENT TYPE VARIANTS**

Variants of the basic type integrated circuits specified herein, which are also covered by this specification, are given in Table 1(a).

**1.3 MAXIMUM RATINGS**

The maximum ratings, which shall not be exceeded at any time during use or storage, applicable to the integrated circuits specified herein, are as scheduled in Table 1(b).

**1.4 PARAMETER DERATING INFORMATION (FIGURE 1)**

Not applicable.

**1.5 PHYSICAL DIMENSIONS**

The physical dimensions of the integrated circuits specified herein are shown in Figure 2.

**1.6 PIN ASSIGNMENT**

As per Figure 3(a).

**1.7 TRUTH TABLE**

As per Figure 3(b).

**1.8 CIRCUIT SCHEMATIC**

As per Figure 3(c).

**1.9 FUNCTIONAL DIAGRAM**

As per Figure 3(d).

**TABLE 1(a) - TYPE VARIANTS**

| VARIANT | CASE | FIGURE | LEAD MATERIAL AND/OR FINISH |
|---------|------|--------|-----------------------------|
| 01      | FLAT | 2(a)   | D7                          |
| 02      | FLAT | 2(a)   | G4                          |
| 05      | DIL  | 2(b)   | D7                          |
| 06      | DIL  | 2(b)   | G4                          |
| 07      | DIL  | 2(c)   | D7                          |
| 08      | DIL  | 2(c)   | D3 or D4                    |
| 11      | CCP  | 2(d)   | 7                           |
| 12      | CCP  | 2(d)   | 4                           |

**TABLE 1(b) - MAXIMUM RATINGS**

| No. | CHARACTERISTICS                                    | SYMBOL    | MAXIMUM RATINGS | UNIT | REMARKS          |
|-----|----------------------------------------------------|-----------|-----------------|------|------------------|
| 1   | Supply Voltage                                     | $V_{CC}$  | -0.5 to 7.0     | V    | -                |
| 2   | Input Voltage                                      | $V_{IN}$  | -0.5 to 7.0     | V    | Note 1           |
| 3   | Device Dissipation                                 | $P_D$     | 33              | mWdc | Note 2           |
| 4   | Operating Temperature Range                        | $T_{op}$  | -55 to +125     | °C   | -                |
| 5   | Storage Temperature Range                          | $T_{stg}$ | -65 to +150     | °C   | -                |
| 6   | Soldering Temperature<br>For FP and DIL<br>For CCP | $T_{sol}$ | +265<br>+245    | °C   | Note 3<br>Note 4 |

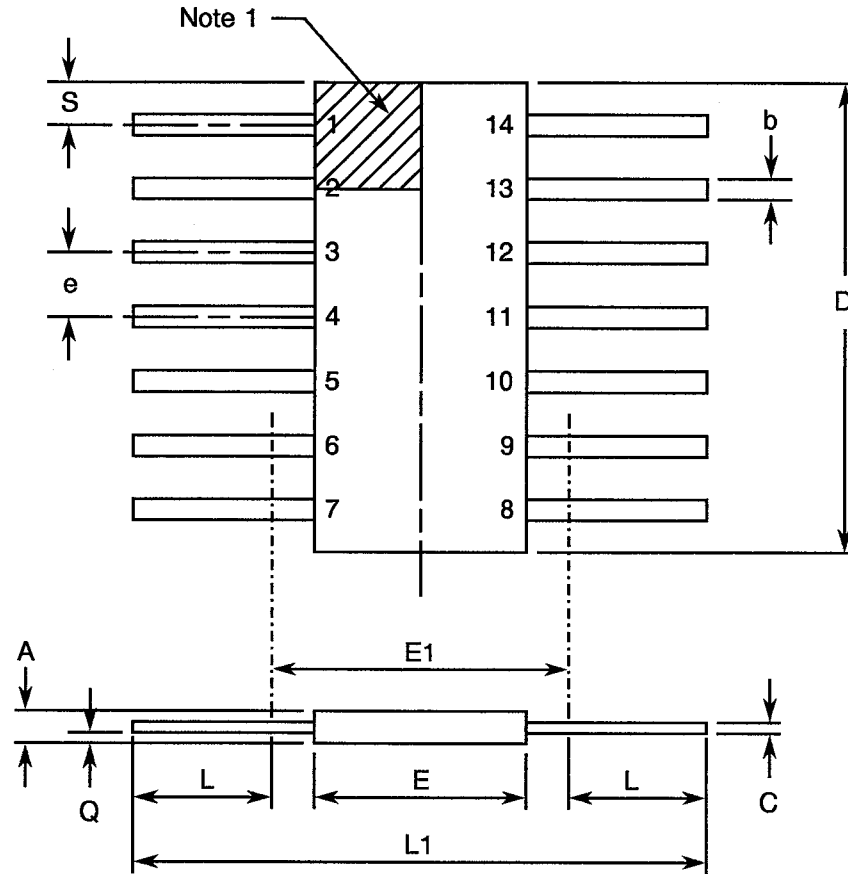
**NOTES**

1. Input current limited to -18mA.
2. Must withstand added PD due to short circuit conditions (i.e. IOS) at one output for 5 seconds.
3. Duration 10 seconds maximum at a distance of not less than 1.5mm from the device body and the same lead shall not be resoldered until 3 minutes have elapsed.
4. Duration 5 seconds maximum and the same terminal shall not be resoldered until 3 minutes have elapsed.



**FIGURE 2 - PHYSICAL DIMENSIONS**

**FIGURE 2(a) - FLAT PACKAGE**



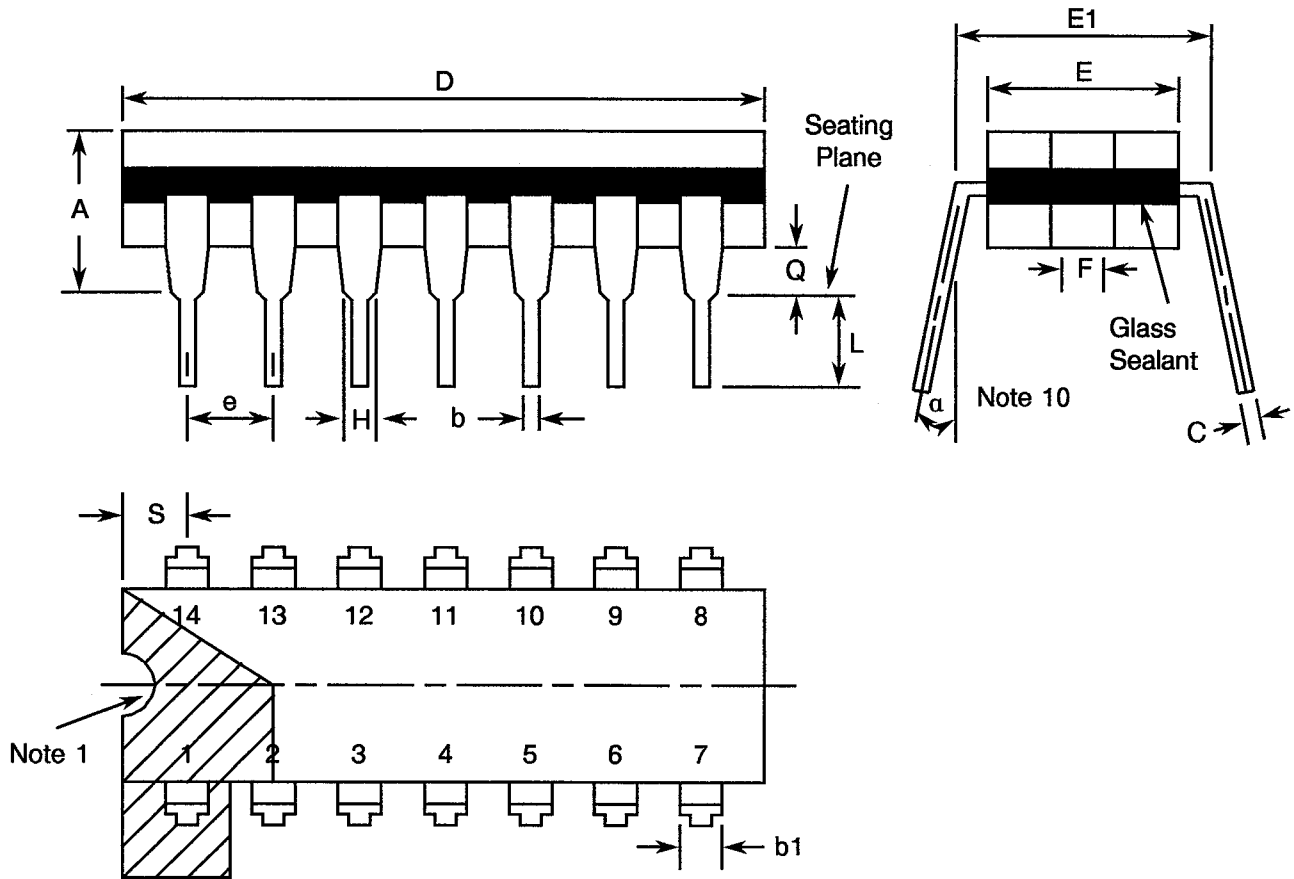
| SYMBOL | MILLIMETRES  |       | NOTES |
|--------|--------------|-------|-------|
|        | MIN          | MAX   |       |
| A      | 1.27         | 2.03  |       |
| b      | 0.38         | 0.56  | 8     |
| C      | 0.08         | 0.23  | 8     |
| D      | 8.56         | 8.89  | 4     |
| E      | 5.97         | 6.73  |       |
| E1     | 7.00 TYPICAL |       | 4     |
| e      | 1.27 TYPICAL |       | 5, 9  |
| L      | 6.86         | 8.00  | 8     |
| L1     | 21.34        | 21.84 |       |
| Q      | 0.51         | 1.02  | 2     |
| S      | 0.25         | 0.64  | 7     |

**NOTES:** See Page 11.



**FIGURE 2 - PHYSICAL DIMENSIONS (CONTINUED)**

**FIGURE 2(b) - DUAL-IN-LINE PACKAGE**



| SYMBOL | MILLIMETRES  |       | NOTES |
|--------|--------------|-------|-------|
|        | MIN          | MAX   |       |
| A      | -            | 5.08  |       |
| b      | 0.38         | 0.66  | 8     |
| b1     | -            | 1.78  | 8     |
| C      | 0.20         | 0.44  | 8     |
| D      | 19.18        | 19.94 | 4     |
| E      | 6.22         | 7.62  | 4     |
| E1     | 7.37         | 8.13  |       |
| e      | 2.54 TYPICAL |       | 6, 9  |
| F      | 1.27 TYPICAL |       |       |
| H      | 0.76         | -     | 8     |
| L      | 3.30         | 5.08  | 8     |
| Q      | 0.51         | -     | 3     |
| S      | 1.78         | 2.54  | 7     |
| a      | 0°           | 15°   | 10    |

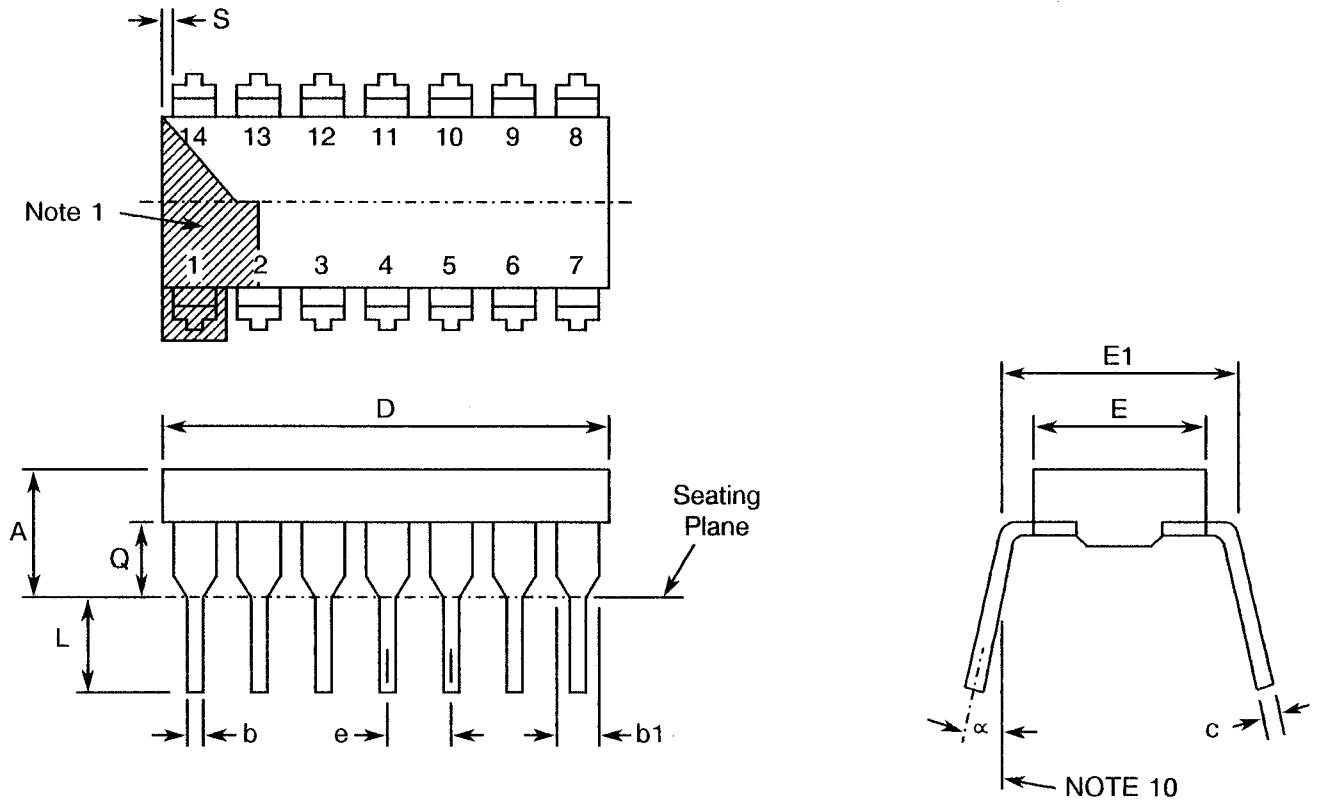
**NOTES:** See Page 11.





**FIGURE 2 - PHYSICAL DIMENSIONS (CONTINUED)**

**FIGURE 2(c) - DUAL-IN-LINE PACKAGE**



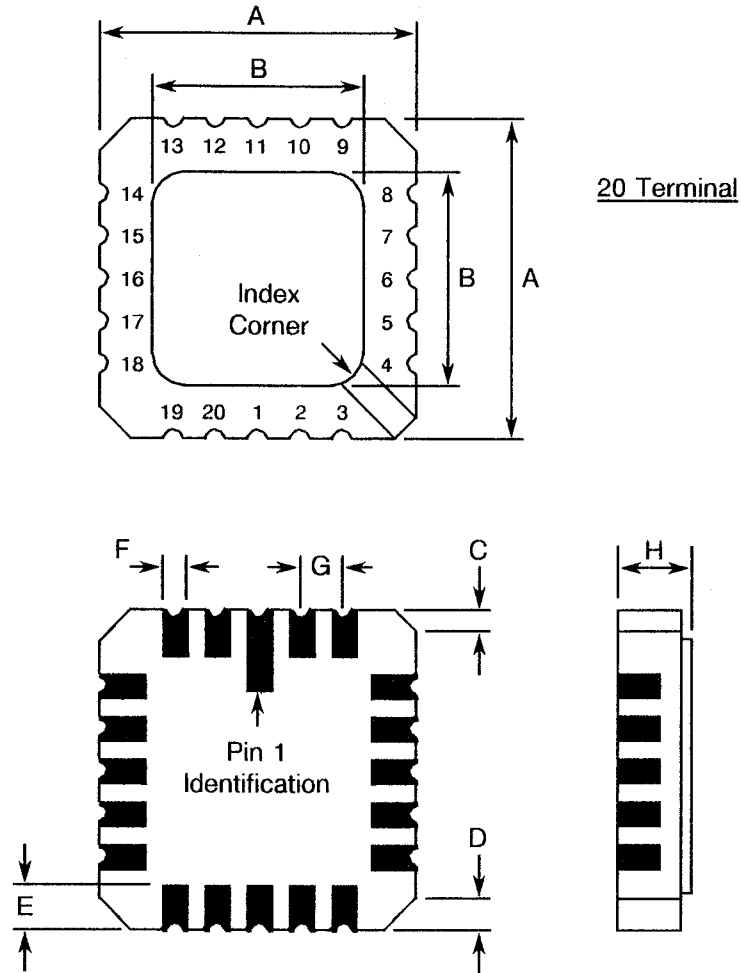
| SYMBOL | MILLIMETRES  |       | NOTES |
|--------|--------------|-------|-------|
|        | MIN.         | MAX.  |       |
| A      | -            | 5.08  | -     |
| b      | 0.36         | 0.58  | 8     |
| b1     | 0.76         | 1.78  | 8     |
| c      | 0.20         | 0.38  | 8     |
| D      | 16.26        | 19.96 | -     |
| E      | 5.59         | 7.87  | -     |
| E1     | 7.37         | 8.13  | 4     |
| e      | 2.54 TYPICAL |       | 6, 9  |
| L      | 3.18         | 5.08  | -     |
| Q      | 0.38         | 2.03  | 3     |
| S      | 0.25         | 1.35  | 7     |
| α      | 0°           | 15°   | 10    |

**NOTES:** See Page 11.



**FIGURE 2 - PHYSICAL DIMENSIONS (CONTINUED)**

**FIGURE 2(d) - SQUARE CHIP CARRIER PACKAGE (3 LAYER BASE)**



| SYMBOL | MILLIMETRES  |       | NOTES |
|--------|--------------|-------|-------|
|        | MIN.         | MAX.  |       |
| A      | 8.687        | 9.093 | -     |
| B      | 7.798        | 9.093 | -     |
| C      | 0.250        | 0.510 | 11    |
| D      | 0.889        | 1.143 | 12    |
| E      | 1.140        | 1.400 | 8     |
| F      | 0.559        | 0.712 | 8     |
| G      | 1.27 TYPICAL |       | 5, 9  |
| H      | 1.630        | 2.540 | -     |

**NOTES:** See Page 11.

**SCC**

ESA/SCC Detail Specification

No. 9203/014

PAGE 11

ISSUE 5

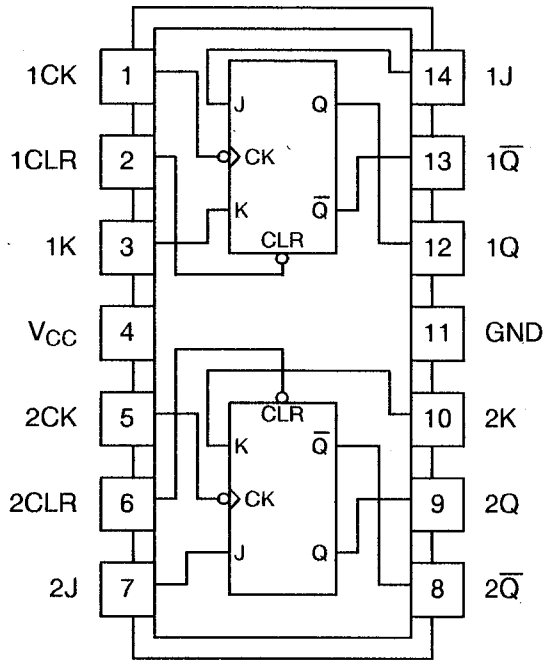
**FIGURE 2 - PHYSICAL DIMENSIONS (CONTINUED)****NOTES TO FIGURES 2(a) TO 2(d)**

1. Index area; a notch or a dot shall be located adjacent to Pin 1 and shall be within the shaded area shown. For chip carrier packages, the index shall be as shown in Figure 2(d).
2. Dimension Q shall be measured at the point of exit of the lead from the body.
3. Dimension Q shall be measured from the seating plane to the base plane.
4. This dimension allows for off-centre lids, meniscus and glass overrun.
5. The true position pin spacing is 1.27mm between centrelines. Each pin centreline shall be located within  $\pm 0.13\text{mm}$  of its true longitudinal position relative to Pins 1 and 14 .
6. The true position pin spacing is 2.54mm between centrelines. Each pin centreline shall be located within  $\pm 0.25\text{mm}$  of its true longitudinal position relative to Pins 1 and 14.
7. Applies to all four corners.
8. All leads or terminals.
9. 12 spaces for flat and dual-in-line packages.  
16 spaces for chip carrier packages.
10. Lead centre when  $\alpha$  is  $0^\circ$ .
11. Index corner only - 2 dimensions.
12. 3 non-index corners - 6 dimensions.



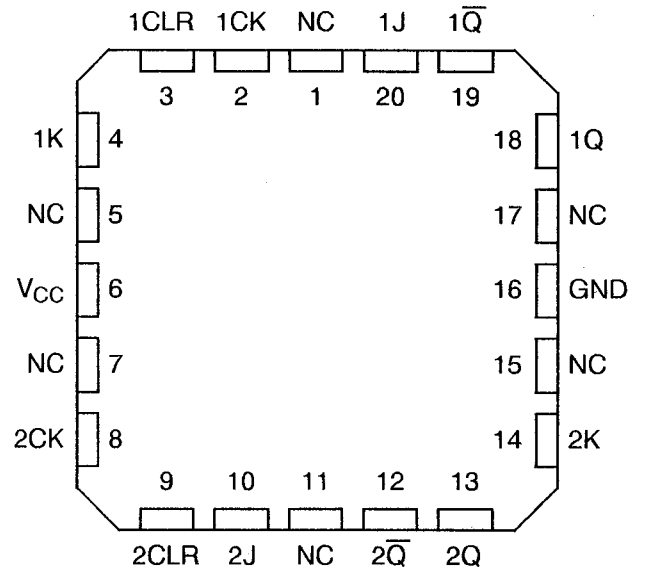
**FIGURE 3(a) - PIN ASSIGNMENT**

DUAL-IN-LINE AND FLAT PACKAGE



(TOP VIEW)

CHIP CARRIER PACKAGE



(TOP VIEW)

FLAT PACKAGE AND DUAL-IN-LINE TO CHIP CARRIER PIN ASSIGNMENT

|                                           |   |   |   |   |   |   |    |    |    |    |    |    |    |    |
|-------------------------------------------|---|---|---|---|---|---|----|----|----|----|----|----|----|----|
| FLAT PACKAGE AND<br>DUAL-IN-LINE PIN OUTS | 1 | 2 | 3 | 4 | 5 | 6 | 7  | 8  | 9  | 10 | 11 | 12 | 13 | 14 |
| CHIP CARRIER PIN OUTS                     | 2 | 3 | 4 | 6 | 8 | 9 | 10 | 12 | 13 | 14 | 16 | 18 | 19 | 20 |

**NOTES**

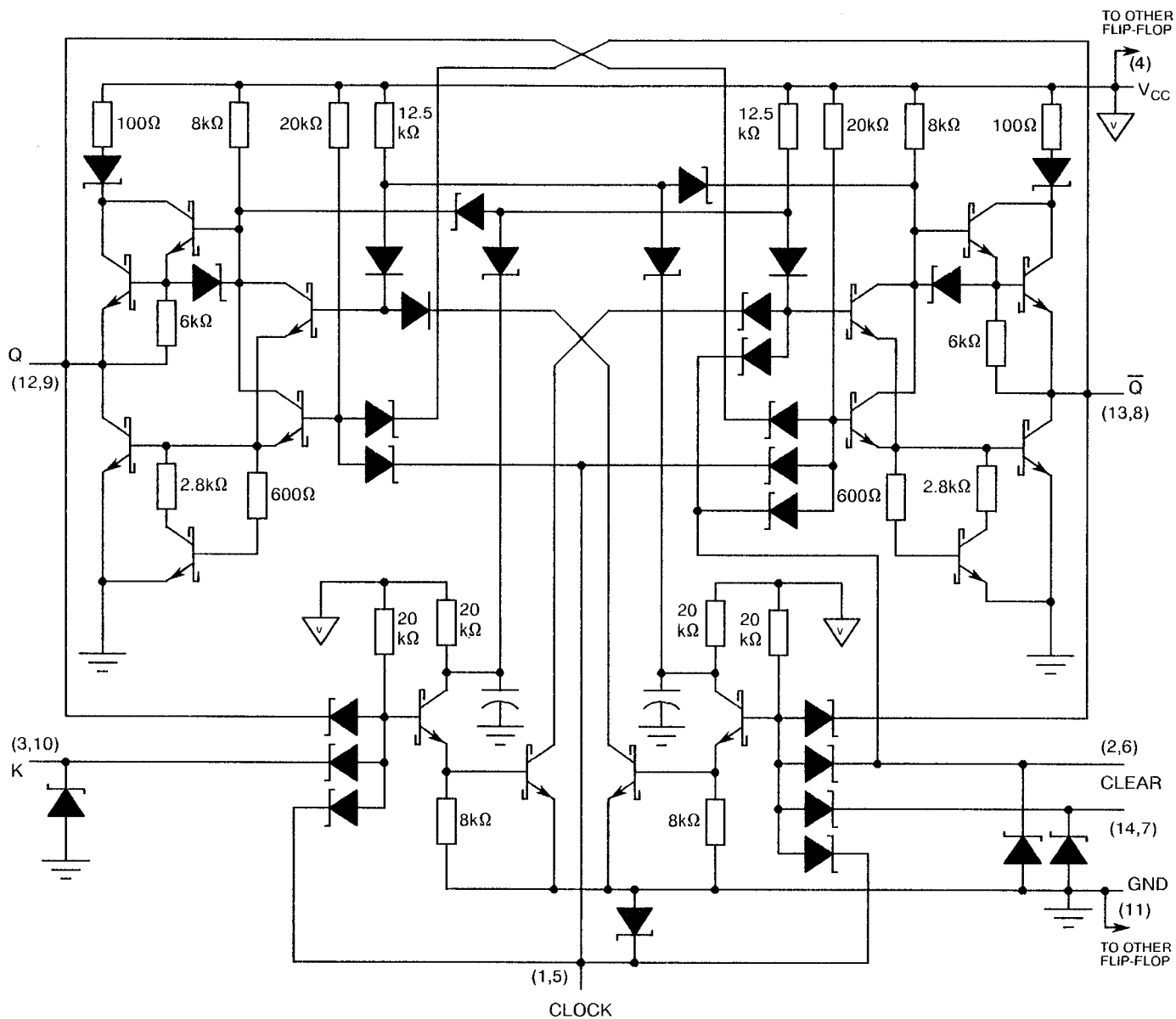
1. All references throughout this specification relate to FLAT/DIL packages only.

**FIGURE 3(b) - TRUTH TABLE (EACH FLIP-FLOP)**

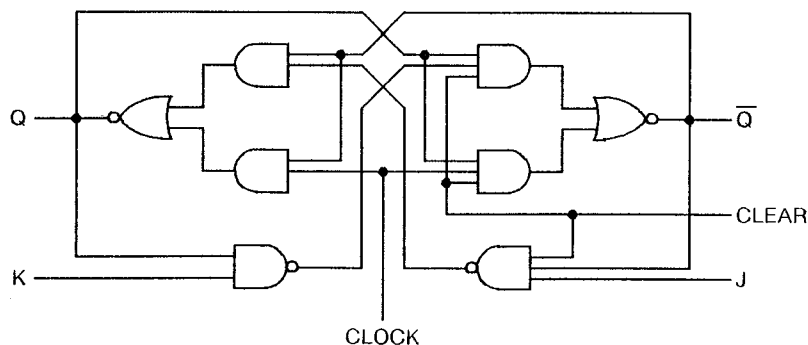
| INPUTS |       |   |   | OUTPUTS |            |
|--------|-------|---|---|---------|------------|
| CLEAR  | CLOCK | J | K | Q       | $\bar{Q}$  |
| L      | X     | X | X | L       | H          |
| H      | ↓     | L | L | Q0      | $\bar{Q}0$ |
| H      | ↓     | H | L | H       | L          |
| H      | ↓     | L | H | L       | H          |
| H      | ↓     | H | H | TOGGLE  |            |
| H      | H     | X | X | Q0      | $\bar{Q}0$ |

**NOTES**

- Logic Level Definitions: L=Low Level (Steady State), H=High Level (Steady State), X=Irrelevant, Q0=Level of Q before indicated steady-state input conditions were established, ↓ =transition from high to low level.

**FIGURE 3(c) - CIRCUIT SCHEMATIC**

**NOTES**

1. All resistive values are nominal.

**FIGURE 3(d) - FUNCTIONAL DIAGRAM (EACH FLIP-FLOP)**


**2. APPLICABLE DOCUMENTS**

The following documents form part of this specification and shall be read in conjunction with it:-

- (a) ESA/SCC Generic Specification No. 9000 for Integrated Circuits.
- (b) MIL-STD-883, Test Methods and Procedures for Micro-electronics.

**3. TERMS, DEFINITIONS, ABBREVIATIONS, SYMBOLS AND UNITS**

For the purpose of this specification, the terms, definitions, abbreviations, symbols and units specified in ESA/SCC Basic Specification No. 21300 shall apply. In addition, the following abbreviation is used:-

- $V_{IC}$  - Input Clamp Voltage.
- $I_{CC}$  - Supply Current.
- $V_{CC}$  - Supply Voltage.

**4. REQUIREMENTS****4.1 GENERAL**

The complete requirements for procurement of the integrated circuits specified herein are stated in this specification and ESA/SCC Generic Specification No. 9000 for Integrated Circuits. Deviations from the Generic Specification applicable to this specification only, are listed in Para. 4.2.

Deviations from the applicable Generic Specification and this Detail Specification, formally agreed with specific Manufacturers on the basis that the alternative requirements are equivalent to the ESA/SCC requirements and do not affect the components' reliability, are listed in the appendices attached to this specification.

**4.2 DEVIATIONS FROM GENERIC SPECIFICATION****4.2.1 Deviations from Special In-process Controls**

None.

**4.2.2 Deviations from Final Production Tests (Chart II)**

None.

**4.2.3 Deviations from Burn-in Tests (Chart III)**

- (a) Para. 7.1.1(a), High Temperature Reverse Bias tests and subsequent electrical measurements related to this test shall be omitted.
- (b) Para. 9.9.2, Electrical Measurements at High and Low Temperatures: Only a test result summary, based on go-no-go tests and presented in histogram form is required.

**4.2.4 Deviations from Qualification Tests (Chart IV)**

None.

**4.2.5 Deviations from Lot Acceptance Tests (Chart V)**

None.



4.3 MECHANICAL REQUIREMENTS

4.3.1 Dimension Check

The dimensions of the integrated circuits specified herein shall be checked. They shall conform to those shown in Figure 2.

4.3.2 Weight

The maximum weight of the integrated circuits specified herein shall be 0.7 grammes for the flat package, 2.2 grammes for the dual-in-line package and 0.6 grammes for the chip carrier package.

4.4 MATERIALS AND FINISHES

The materials and finishes shall be as specified herein. Where a definite material is not specified, a material which will enable the integrated circuits specified herein to meet the performance requirements of this specification shall be used. Acceptance or approval of any constituent material does not guarantee acceptance of the finished product.

4.4.1 Case

The case shall be hermetically sealed and have a metal body with hard glass seals or a ceramic body and the lids shall be welded, brazed, preform-soldered or glass frit-sealed.

4.4.2 Lead Material and Finish

For dual-in-line and flat packages, the material shall be either Type 'D' or Type 'G' with either Type '3' or '4', Type '4' or Type '7' finish in accordance with the requirements of ESA/SCC Basic Specification No. 23500. For chip carrier packages, the finish shall be either Type '4' or Type '7' in accordance with the requirements of ESA/SCC Basic Specification No. 23500. (See Table 1(a) for Type Variants).

4.5 MARKING

4.5.1 General

The marking of all components delivered to this specification shall be in accordance with the requirements of ESA/SCC Basic Specification No. 21700. Each component shall be marked in respect of:-

- (a) Lead Identification.
- (b) The SCC Component Number.
- (c) Traceability Information.

4.5.2 Lead Identification

For dual-in-line and flat packages, an index shall be located at the top of the package in the position defined in Note 1 to Figure 2 or, alternatively, a tab may be used to identify Pin No. 1. The pin numbering must be read with the index or tab on the left-hand side. For chip carrier packages, the index shall be as defined by Figure 2(d).

4.5.3 The SCC Component Number

Each component shall bear the SCC Component Number which shall be constituted and marked as follows:


920301402B

Detail Specification Number \_\_\_\_\_

Type Variant (see Table 1(a)) \_\_\_\_\_

Testing Level (B or C, as applicable) \_\_\_\_\_



|                                                                                  |                                              |                    |
|----------------------------------------------------------------------------------|----------------------------------------------|--------------------|
|  | ESA/SCC Detail Specification<br>No. 9203/014 | PAGE 17<br>ISSUE 5 |
|----------------------------------------------------------------------------------|----------------------------------------------|--------------------|

4.5.4 Traceability Information

Each component shall be marked in respect of traceability information in accordance with the requirements of ESA/SCC Basic Specification No. 21700.

4.6 ELECTRICAL MEASUREMENTS

4.6.1 Electrical Measurements at Room Temperature

The parameters to be measured in respect of electrical characteristics are scheduled in Table 2. Unless otherwise specified, the measurements shall be performed at  $T_{amb} = +22 \pm 3$  °C.

4.6.2 Electrical Measurements at High and Low Temperatures

The parameters to be measured at high and low temperatures are scheduled in Table 3. The measurements shall be performed at  $T_{amb} = +125$  and  $-55$  °C respectively.

4.6.3 Circuits for Electrical Measurements

Circuits for use in performing the electrical measurements listed in Tables 2 and 3 of this specification are shown in Figure 4.

4.7 BURN-IN TESTS

4.7.1 Parameter Drift Values

The parameter drift values applicable to burn-in are specified in Table 4 of this specification. Unless otherwise stated, measurements shall be performed at  $T_{amb} = +22 \pm 3$  °C. The parameter drift values ( $\Delta$ ) applicable to the parameters scheduled, shall not be exceeded. In addition to these drift value requirements, the appropriate limit value specified for a given parameter in Table 2 shall not be exceeded.

4.7.2 Conditions for Power Burn-in

The requirements for power burn-in are specified in Section 7 of ESA/SCC Generic Specification No. 9000. The conditions for power burn-in shall be as specified in Table 5 of this specification.

4.7.3 Electrical Circuits for Power Burn-in

Circuits for use in performing the power burn-in tests are shown in Figure 5 of this specification.



**TABLE 2 - ELECTRICAL MEASUREMENTS AT ROOM TEMPERATURE - D.C. PARAMETERS**

| No.      | CHARACTERISTICS                                        | SYMBOL    | TEST METHOD MIL-STD 883 | TEST FIG. | TEST CONDITIONS (PINS UNDER TEST)                                                         | LIMITS |      | UNIT    |
|----------|--------------------------------------------------------|-----------|-------------------------|-----------|-------------------------------------------------------------------------------------------|--------|------|---------|
|          |                                                        |           |                         |           |                                                                                           | MIN    | MAX  |         |
| 1        | Functional Test                                        | -         | -                       | 3(b)      | Verify Truth Table with Load.<br>Note 1                                                   | -      | -    | -       |
| 2 to 5   | Input Current High Level at J-K                        | $I_{IH1}$ | 3010                    | 4(a)      | $V_{CC} = 5.5V, V_{IN} = 2.7V$<br>(Pins 3-7-10-14)                                        | -      | 20   | $\mu A$ |
| 6 to 9   | Input Current High Level at J-K (Max. Input Voltage)   | $I_{IH2}$ | 3010                    | 4(a)      | $V_{CC} = 5.5V, V_{IN} = 7.0V$<br>(Pins 3-7-10-14)                                        | -      | 100  | $\mu A$ |
| 10 to 11 | Input Current High Level at Clear                      | $I_{IH3}$ | 3010                    | 4(a)      | $V_{CC} = 5.5V, V_{IN} = 2.7V$<br>(Pins 2-6)                                              | -      | 60   | $\mu A$ |
| 12 to 13 | Input Current High Level at Clear (Max. Input Voltage) | $I_{IH4}$ | 3010                    | 4(a)      | $V_{CC} = 5.5V, V_{IN} = 7.0V$<br>(Pins 2-6)                                              | -      | 300  | $\mu A$ |
| 14 to 15 | Input Current High Level at Clock                      | $I_{IH5}$ | 3010                    | 4(a)      | $V_{CC} = 5.5V, V_{IN} = 2.7V$<br>(Pins 1-5)                                              | -      | 80   | $\mu A$ |
| 16 to 17 | Input Current High Level at Clock (Max. Input Voltage) | $I_{IH6}$ | 3010                    | 4(a)      | $V_{CC} = 5.5V, V_{IN} = 7.0V$<br>(Pins 1-5)                                              | -      | 400  | $\mu A$ |
| 18 to 25 | Input Clamp Voltage                                    | $V_{IC}$  | 3009                    | 4(b)      | $V_{CC} = 4.5V, I_{IN} = -18mA$<br>Note 2<br>(Pins 1-2-3-5-6-7-10-14)                     | -      | -1.5 | V       |
| 26 to 29 | Input Current Low Level at J-K                         | $I_{IL1}$ | 3009                    | 4(c)      | $V_{CC} = 5.5V, V_{IN} = 0.4V$<br>(Pins 3-7-10-14)                                        | -      | -400 | $\mu A$ |
| 30 to 33 | Input Current Low Level at Clear and Clock             | $I_{IL2}$ | 3009                    | 4(c)      | $V_{CC} = 5.5V, V_{IN} = 0.4V$<br>(Pins 1-2-5-6)                                          | -      | -800 | $\mu A$ |
| 34 to 37 | Output Voltage Low Level                               | $V_{OL}$  | 3007                    | 4(d)      | $V_{CC} = 4.5V, V_{IL} = 0.7V$<br>$V_{IH} = 2.0V, I_{OL} = 4.0mA$<br>(Pins 8-9-12-13)     | -      | 0.4  | V       |
| 38 to 41 | Output Voltage High Level                              | $V_{OH}$  | 3006                    | 4(e)      | $V_{CC} = 4.5V, V_{IL} = 0.7V$<br>$V_{IH} = 2.0V, I_{OH} = -400\mu A$<br>(Pins 8-9-12-13) | 2.5    | -    | V       |
| 42 to 45 | Output Current Short Circuit                           | $I_{OS}$  | 3011                    | 4(f)      | $V_{CC} = 5.5V$<br>Note 3<br>(Pins 8-9-12-13)                                             | -20    | -100 | mA      |
| 46 to 47 | Supply Current                                         | $I_{CC}$  | 3005                    | 4(g)      | $V_{CC} = 5.5V$<br>$V_{IN (CLOCK)} = 0V$<br>Note 4<br>(Pin 4)                             | -      | 6.0  | mA      |

**NOTES:** See Page 19.



**TABLE 2 - ELECTRICAL MEASUREMENTS AT ROOM TEMPERATURE - A.C. PARAMETERS**

| No.      | CHARACTERISTICS                                          | SYMBOL    | TEST METHOD MIL-STD 883 | TEST FIG. | TEST CONDITIONS (PINS UNDER TEST) (NOTE 6)                                    | LIMITS |     | UNIT |
|----------|----------------------------------------------------------|-----------|-------------------------|-----------|-------------------------------------------------------------------------------|--------|-----|------|
|          |                                                          |           |                         |           |                                                                               | MIN    | MAX |      |
| 48 to 51 | Propagation Delay, Low to High Level from Clock or Clear | $t_{PLH}$ | 3003                    | 4(h)      | $V_{CC} = 5.0V$<br>$R_L = 2.0k\Omega$<br>$C_L = 15pF$<br>(Pins 8-9-12-13)     | -      | 20  | ns   |
| 52 to 55 | Propagation Delay, High to Low Level from Clock or Clear | $t_{PHL}$ | 3003                    | 4(h)      | $V_{CC} = 5.0V$<br>$R_L = 2.0k\Omega$<br>$C_L = 15pF$<br>(Pins 8-9-12-13)     | -      | 20  | ns   |
| 56 to 59 | Maximum Clock Frequency                                  | $f_{max}$ | -                       | 4(h)      | $V_{CC} = 5.0V$<br>$R_L = 2.0k\Omega$<br>$C_L = 15pF$<br>Note 5<br>(Pins 1-5) | 30     | -   | MHz  |

**NOTES**

1. Go-no-go test with  $V_{IL} = 0.3V$ ;  $V_{IH} = 3.0V$ ; trip point 1.5V.
2. All inputs and outputs not under test shall be open.
3. No more than one output should be shorted at a time, and only for 1 second maximum.  $I_{OS}$  measurement may be performed with  $V_{OUT} = 2.25V$  instead of 0V. In this case, the limits are divided by 2.
4. With all outputs open and 4.5V applied to all data and clear inputs,  $I_{CC}$  is measured with Q and  $\bar{Q}$  high in turn. At the time of measurement, the clock input is grounded.
5. This parameter shall be measured only when required by the Purchase Order. In any case, the Manufacturer shall guarantee that the device meets this requirement.
6. Propagation delay measurements shall be performed as a go-no-go test on a 100% basis. Read-and-record measurements shall be performed on an LTPD7 sample basis following the Chart III Burn-in Test.



**TABLE 3 - ELECTRICAL MEASUREMENTS AT HIGH AND LOW TEMPERATURES,  
+ 125(+ 0 - 5) °C AND - 55(+ 5 - 0) °C**

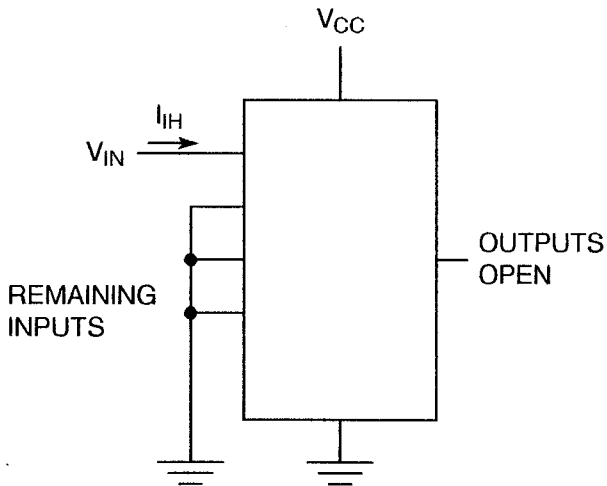
| No.      | CHARACTERISTICS                                        | SYMBOL    | TEST METHOD MIL-STD 883 | TEST FIG. | TEST CONDITIONS (PINS UNDER TEST)                                                         | LIMITS |       | UNIT    |
|----------|--------------------------------------------------------|-----------|-------------------------|-----------|-------------------------------------------------------------------------------------------|--------|-------|---------|
|          |                                                        |           |                         |           |                                                                                           | MIN    | MAX   |         |
| 1        | Functional Test                                        | -         | -                       | 3(b)      | Verify Truth Table with Load.<br>Note 1                                                   | -      | -     | -       |
| 2 to 5   | Input Current High Level at J-K                        | $I_{IH1}$ | 3010                    | 4(a)      | $V_{CC} = 5.5V, V_{IN} = 2.7V$<br>(Pins 3-7-10-14)                                        | -      | 20    | $\mu A$ |
| 6 to 9   | Input Current High Level at J-K (Max. Input Voltage)   | $I_{IH2}$ | 3010                    | 4(a)      | $V_{CC} = 5.5V, V_{IN} = 7.0V$<br>(Pins 3-7-10-14)                                        | -      | 100   | $\mu A$ |
| 10 to 11 | Input Current High Level at Clear                      | $I_{IH3}$ | 3010                    | 4(a)      | $V_{CC} = 5.5V, V_{IN} = 2.7V$<br>(Pins 2-6)                                              | -      | 60    | $\mu A$ |
| 12 to 13 | Input Current High Level at Clear (Max. Input Voltage) | $I_{IH4}$ | 3010                    | 4(a)      | $V_{CC} = 5.5V, V_{IN} = 7.0V$<br>(Pins 2-6)                                              | -      | 300   | $\mu A$ |
| 14 to 15 | Input Current High Level at Clock                      | $I_{IH5}$ | 3010                    | 4(a)      | $V_{CC} = 5.5V, V_{IN} = 2.7V$<br>(Pins 1-5)                                              | -      | 80    | $\mu A$ |
| 16 to 17 | Input Current High Level at Clock (Max. Input Voltage) | $I_{IH6}$ | 3010                    | 4(a)      | $V_{CC} = 5.5V, V_{IN} = 7.0V$<br>(Pins 1-5)                                              | -      | 400   | $\mu A$ |
| 18 to 25 | Input Clamp Voltage                                    | $V_{IC}$  | 3009                    | 4(b)      | $V_{CC} = 4.5V, I_{IN} = -18mA$<br>Note 2<br>(Pins 1-2-3-5-6-7-10-14)                     | -      | - 1.5 | V       |
| 26 to 29 | Input Current Low Level at J-K                         | $I_{IL1}$ | 3009                    | 4(c)      | $V_{CC} = 5.5V, V_{IN} = 0.4V$<br>(Pins 3-7-10-14)                                        | -      | - 400 | $\mu A$ |
| 30 to 33 | Input Current Low Level at Clear and Clock             | $I_{IL2}$ | 3009                    | 4(c)      | $V_{CC} = 5.5V, V_{IN} = 0.4V$<br>(Pins 1-2-5-6)                                          | -      | - 800 | $\mu A$ |
| 34 to 37 | Output Voltage Low Level                               | $V_{OL}$  | 3007                    | 4(d)      | $V_{CC} = 4.5V, V_{IL} = 0.7V$<br>$V_{IH} = 2.0V, I_{OL} = 4.0mA$<br>(Pins 8-9-12-13)     | -      | 0.4   | V       |
| 38 to 41 | Output Voltage High Level                              | $V_{OH}$  | 3006                    | 4(e)      | $V_{CC} = 4.5V, V_{IL} = 0.7V$<br>$V_{IH} = 2.0V, I_{OH} = -400\mu A$<br>(Pins 8-9-12-13) | 2.5    | -     | V       |
| 42 to 45 | Output Current Short Circuit                           | $I_{OS}$  | 3011                    | 4(f)      | $V_{CC} = 5.5V$<br>Note 3<br>(Pins 8-9-12-13)                                             | - 20   | - 100 | mA      |
| 46 to 47 | Supply Current                                         | $I_{CC}$  | 3005                    | 4(g)      | $V_{CC} = 5.5V$<br>$V_{IN (CLOCK)} = 0V$<br>Note 4<br>(Pin 4)                             | -      | 6.0   | mA      |

**NOTES:** See Page 19.



**FIGURE 4 - CIRCUITS FOR ELECTRICAL MEASUREMENTS**

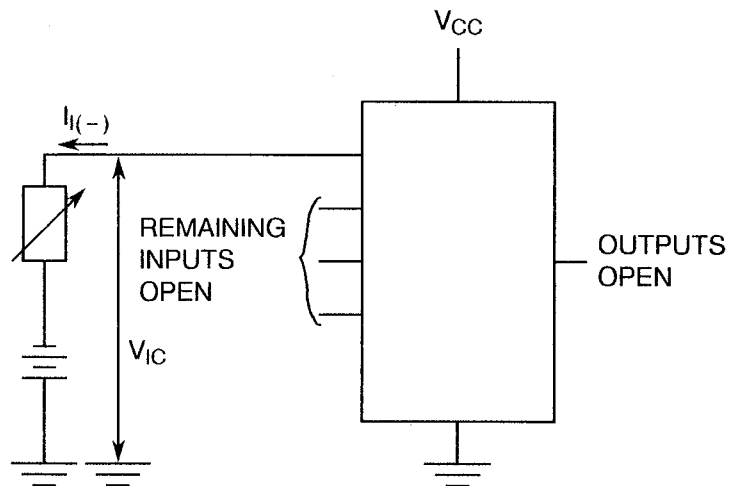
**FIGURE 4(a) - HIGH LEVEL INPUT CURRENT**



**NOTES**

- 1. Each input to be tested separately.

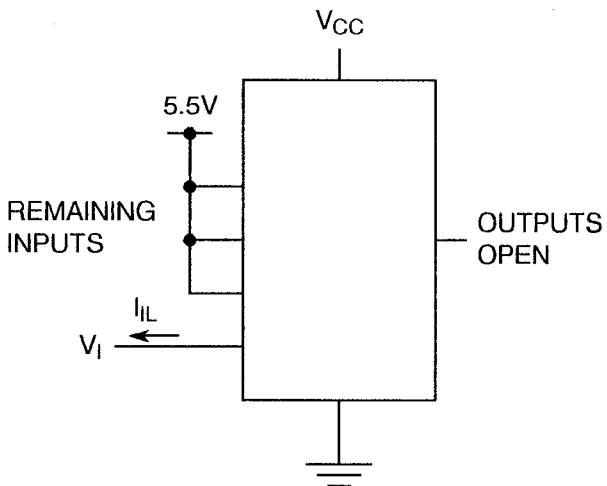
**FIGURE 4(b) - INPUT CLAMP VOLTAGE**



**NOTES**

- 1. Each input to be tested separately.

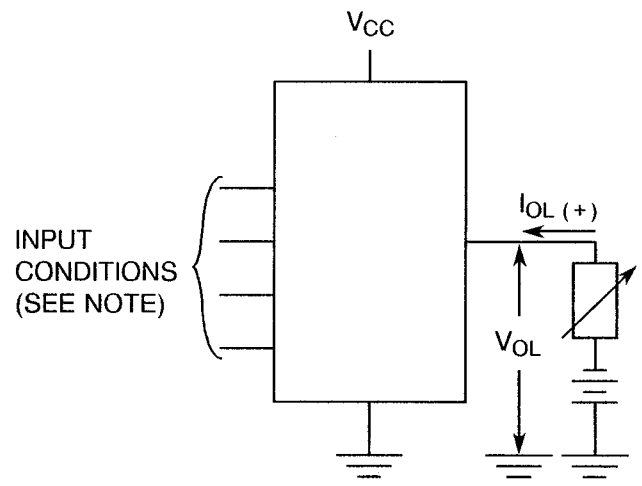
**FIGURE 4(c) - LOW LEVEL INPUT CURRENT**



**NOTES**

- 1. Each input to be tested separately.

**FIGURE 4(d) - LOW LEVEL OUTPUT VOLTAGE**



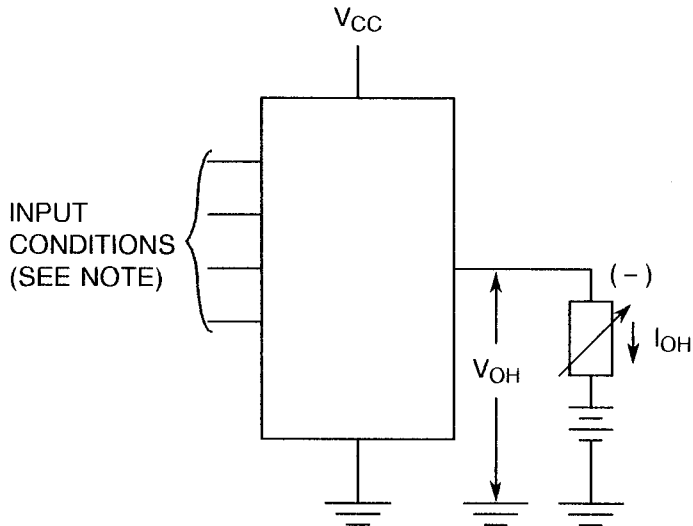
**NOTES**

- 1. Test per Truth Table.



**FIGURE 4 - CIRCUITS FOR ELECTRICAL MEASUREMENTS (CONTINUED)**

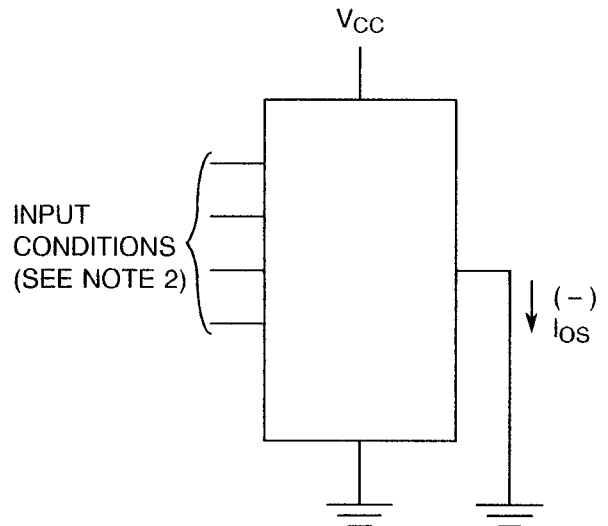
FIGURE 4(e) - HIGH LEVEL OUTPUT VOLTAGE



**NOTES**

1. Test per Truth Table.

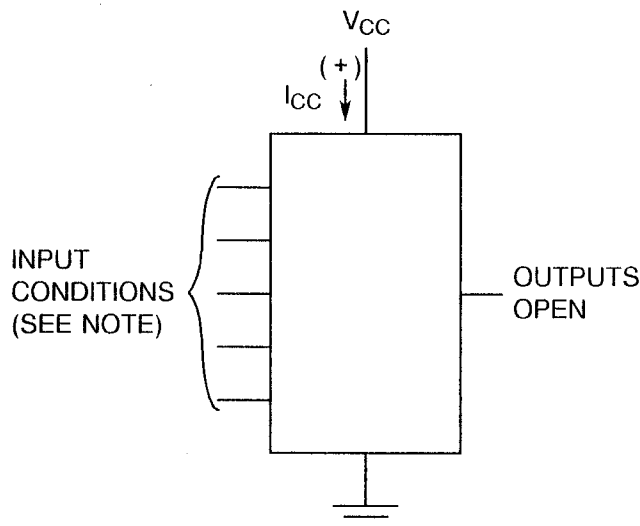
FIGURE 4(f) - SHORT CIRCUIT OUTPUT CURRENT



**NOTES**

1. No more than one output should be shorted at a time.
2. Test per Truth Table.

FIGURE 4(g) - SUPPLY CURRENT



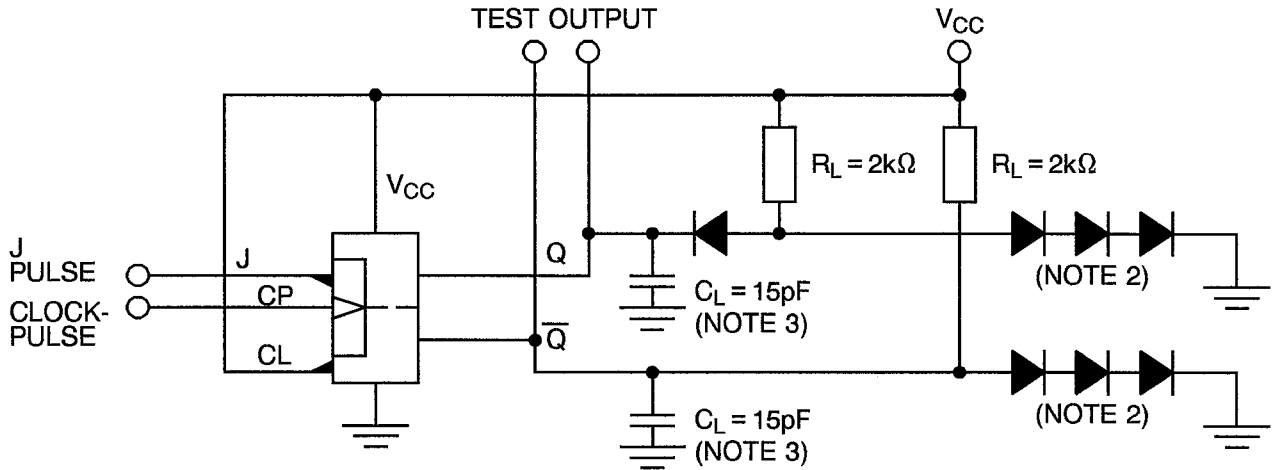
**NOTES**

1. See Note 4 for Table 2.

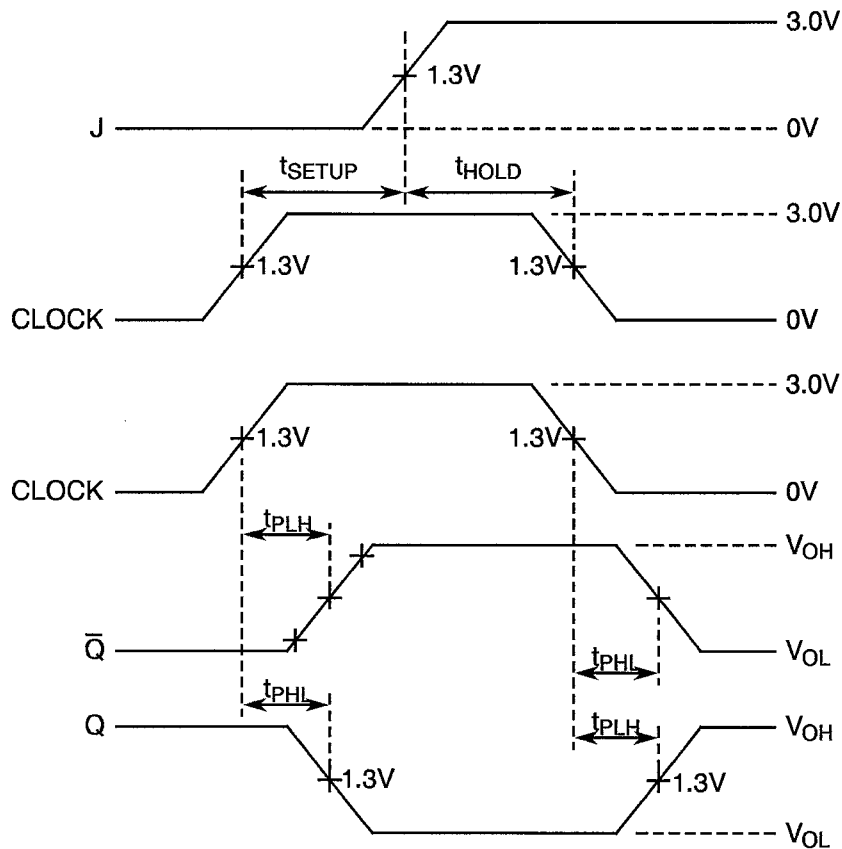


**FIGURE 4 - CIRCUITS FOR ELECTRICAL MEASUREMENTS (CONTINUED)**

**FIGURE 4(h) - DYNAMIC TEST AND SWITCHING WAVEFORMS**



**VOLTAGE WAVEFORMS**



**NOTES**

1. The generator has the following characteristics:  $V_{GEN} = 3.0 \pm 0.2V$ ,  $t_r < 6.0ns$ ,  $t_f < 15ns$ ,  $t_p = 0.5\mu s$ ,  $PRR = 1.0MHz$ ,  $Z_{out} = 50\Omega$ .
2. All diodes are 1N916 or 1N3064.
3.  $C_L = 15pF \pm 15\%$  including scope probe, wiring and stray capacitance without package in the test fixtures.
4. Each flip-flop tested separately.

**TABLE 4 - PARAMETER DRIFT VALUES**

| No.      | CHARACTERISTICS           | SYMBOL   | SPEC. AND/OR TEST METHOD | TEST CONDITIONS | CHANGE LIMITS ( $\Delta$ )      | UNIT         |
|----------|---------------------------|----------|--------------------------|-----------------|---------------------------------|--------------|
| 2 to 5   | Input Current High Level  | $I_{IH}$ | As per Table 2           | As per Table 2  | $\pm 20$<br>or (1)<br>$\pm 0.5$ | %<br>$\mu A$ |
| 26 to 29 | Input Current Low Level   | $I_{IL}$ | As per Table 2           | As per Table 2  | $\pm 18$                        | $\mu A$      |
| 34 to 37 | Output Voltage Low Level  | $V_{OL}$ | As per Table 2           | As per Table 2  | $\pm 60$                        | mV           |
| 38 to 41 | Output Voltage High Level | $V_{OH}$ | As per Table 2           | As per Table 2  | $\pm 240$                       | mV           |

**NOTES**

1. Whichever is greater, referred to the initial value.

**TABLE 5 - CONDITIONS FOR POWER BURN-IN AND OPERATING LIFE TEST**

| No. | CHARACTERISTICS      | SYMBOL    | CONDITION            | UNIT        |
|-----|----------------------|-----------|----------------------|-------------|
| 1   | Ambient Temperature  | $T_{amb}$ | + 125(+ 0 - 5)       | $^{\circ}C$ |
| 2   | Power Supply Voltage | $V_{CC}$  | + 5(+ 0.5 - 0)       | V           |
| 3   | Pulse Voltage        | $V_{GEN}$ | 0.5 max. to 3.0 min. | V           |
| 4   | Frequency            | f         | 100<br>(See Note 1)  | Hz          |
| 5   | Fan-out              | -         | 10                   | -           |
| 6   | Rise Time            | $t_r$     | 50 max.              | $\mu s$     |
| 7   | Fall Time            | $t_f$     | 50 max.              | $\mu s$     |
| 8   | Duty Cycle           | -         | 20 min.              | %           |

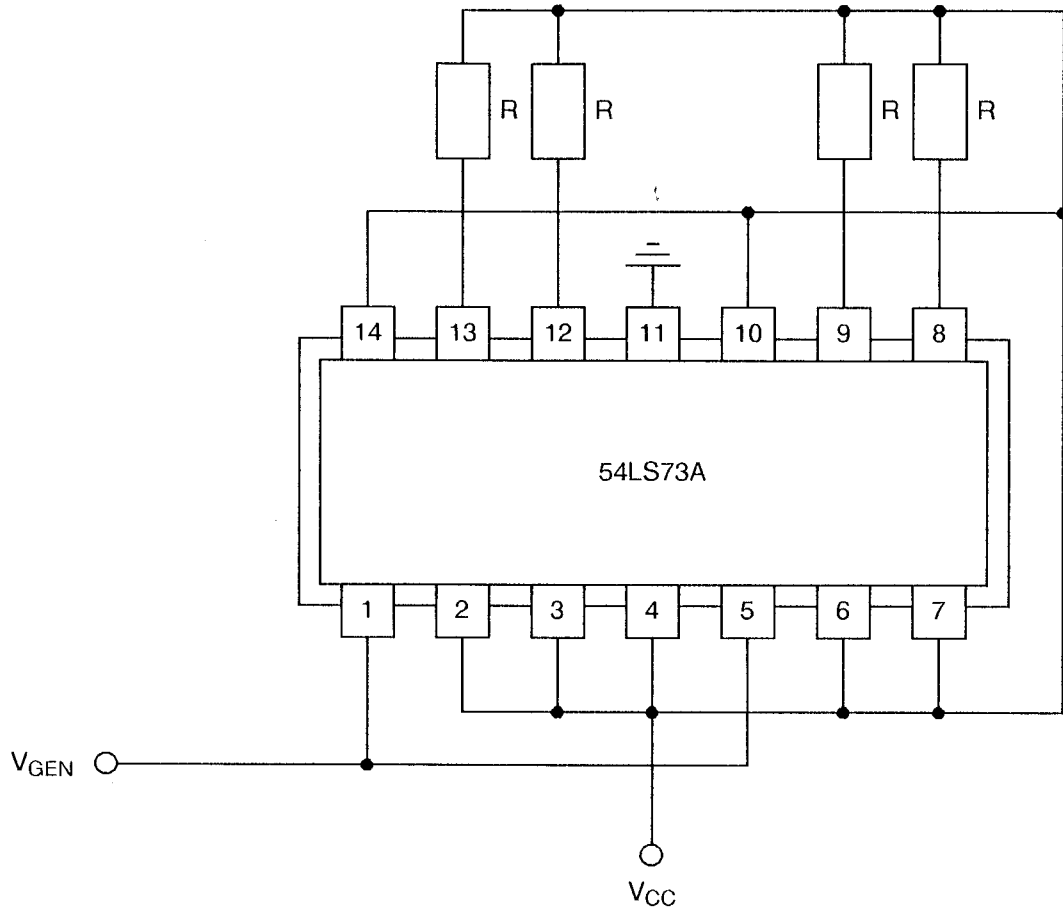
**NOTES**

1. Tolerance  $\pm 10\%$ .







**FIGURE 5 - ELECTRICAL CIRCUIT FOR POWER BURN-IN AND OPERATING LIFE TEST**



**NOTES**

1.  $R = 1.2k\Omega$ .

|                                                                                                                                                                     |                                              |                    |
|---------------------------------------------------------------------------------------------------------------------------------------------------------------------|----------------------------------------------|--------------------|
|   | ESA/SCC Detail Specification<br>No. 9203/014 | PAGE 26<br>ISSUE 5 |
|---------------------------------------------------------------------------------------------------------------------------------------------------------------------|----------------------------------------------|--------------------|

4.8 ENVIRONMENTAL AND ENDURANCE TESTS (CHARTS IV AND V OF ESA/SCC GENERIC SPECIFICATION NO. 9000)

4.8.1 Electrical Measurements on Completion of Environmental Tests

The parameters to be measured on completion of environmental tests are scheduled in Table 6. Unless otherwise stated, the measurements shall be performed at  $T_{amb} = +22 \pm 3 \text{ }^\circ\text{C}$ .

4.8.2 Electrical Measurements at Intermediate Points during Endurance Tests

The parameters to be measured at intermediate points during endurance tests are as scheduled in Table 6 of this specification.

4.8.3 Electrical Measurements on Completion of Endurance Tests

The parameters to be measured on completion of endurance testing are as scheduled in Table 6 of this specification. Unless otherwise stated, the measurements shall be performed at  $T_{amb} = +22 \pm 3 \text{ }^\circ\text{C}$ .

4.8.4 Conditions for Operating Life Tests

The requirements for operating life testing are specified in Section 9 of ESA/SCC Generic Specification No. 9000. The conditions for operating life testing shall be as specified in Table 5 of this specification.

4.8.5 Electrical Circuits for Operating Life Tests

Circuits for use in performing the operating life tests are shown in Figure 5.

4.8.6 Conditions for High Temperature Storage Test

The requirements for the high temperature storage test are specified in ESA/SCC Generic Specification No. 9000. The conditions for high temperature storage shall be  $T_{amb} = +150(+0-5) \text{ }^\circ\text{C}$ .

**TABLE 6 - ELECTRICAL MEASUREMENTS ON COMPLETION OF ENVIRONMENTAL TESTS AND AT INTERMEDIATE POINTS AND ON COMPLETION OF ENDURANCE TESTS**

| No.      | CHARACTERISTICS                                 | SYMBOL    | SPEC. AND/OR TEST METHOD | TEST CONDITIONS | CHANGE LIMITS |          | UNIT    |
|----------|-------------------------------------------------|-----------|--------------------------|-----------------|---------------|----------|---------|
|          |                                                 |           |                          |                 | ( $\Delta$ )  | ABSOLUTE |         |
| 2 to 5   | Input Current High Level 1                      | $I_{IH1}$ | As per Table 2           | As per Table 2  | $\pm 1.0$     | -        | $\mu A$ |
| 6 to 9   | Input Current High Level 2 (Max. Input Voltage) | $I_{IH2}$ | As per Table 2           | As per Table 2  | -             | 100      | $\mu A$ |
| 26 to 29 | Input Current Low Level                         | $I_{IL}$  | As per Table 2           | As per Table 2  | $\pm 12$      | -        | $\mu A$ |
| 34 to 37 | Output Voltage Low Level                        | $V_{OL}$  | As per Table 2           | As per Table 2  | $\pm 60$      | -        | mV      |
| 38 to 41 | Output Voltage High Level                       | $V_{OH}$  | As per Table 2           | As per Table 2  | $\pm 240$     | -        | mV      |
| 46 to 47 | Supply Current                                  | $I_{CC}$  | As per Table 2           | As per Table 2  | $\pm 20$      | -        | %       |

**SCC**ESA/SCC Detail Specification  
No. 9203/014

PAGE 28

ISSUE 5

**APPENDIX 'A'**

Page 1 of 1

**AGREED DEVIATIONS FOR TEXAS INSTRUMENTS (F)**

| ITEMS AFFECTED          | DESCRIPTION OF DEVIATIONS                                                                                                                                         |
|-------------------------|-------------------------------------------------------------------------------------------------------------------------------------------------------------------|
| Para. 4.2.1             | Scanning Electron Microscope (SEM) Inspection may be performed using TIF document TIF 3.61.610.001.                                                               |
| Para. 4.2.2             | Prior to Die Shear Test TIF may perform a Radiographic Inspection on the randomly chosen samples to be subjected to this test, using TIF document TIF 50.42-3002. |
| Para. 4.2.3             | Radiographic Inspection may be performed using TIF document TIF 50.42-3002.                                                                                       |
| Table 3, Tests 34 to 41 | Electrical measurement may be performed with $V_{IL} = 600\text{mV}$ for $V_{OL}$ and $V_{OH}$ testing.                                                           |