



**european space agency
agence spatiale européenne**



Pages 1 to 31

**INTEGRATED CIRCUITS, SILICON MONOLITHIC,
BIPOLAR 16-BIT SHIFT REGISTER,
BASED ON TYPE 54LS673**

ESA/SCC Detail Specification No. 9306/035



**space components
coordination group**

Issue/Rev.	Date	Approved by	
		SCCG Chairman	ESA Director General or his Deputy
Issue 2	March 1994		



DOCUMENTATION CHANGE NOTICE

Rev. Letter	Rev. Date	Reference	CHANGE Item	Approved DCR No.
		This issue supersedes Issue 1 and incorporates all modifications defined in Revisions 'A', 'B', 'C' and 'D' to Issue 1 and the following DCR's:-		None
		Cover page		None
		DCN		None
		Table 1(a)	: Lead Material and/or Finish amended for existing Variants	221106
			: Variants 11 and 12 added	221106
		Table 1(b)	: No. 2, in Remarks, Note No. amended to "1"	23573
			: No. 3, in Remarks, Note No. amended to "2"	23573
			: No. 6, existing temperature specified for FP/DIP	23573
			, new temperature and Note reference added for CCP	23573
			: Note 1 renumbered as "2"	23573
			: Note 2 renumbered as "3" and text amended	23573
			: Note 3 renumbered as "1"	23573
			: New Note 4 added	23573
		Figures 2(a), (b)	: Drawing and Table amended	221106
		Figure 2(c)	: Reference to Note 6 amended to "Note 10"	23519
			: Imperial Dimensions deleted	22881
			: Note references corrected	221106
		Figure 2(d)	: New figure added	221106
		Notes to Figures	: Existing Notes deleted and new Notes added	221106
		Figure 3(a)	: Figure for chip carrier package added	221106
			: Original subtitle deleted, and new subtitles added above both drawings	221106
			: Comparison table added	221106
			: Note 1 added	221106
		Figure 3(b)	: Note amended	23519
			: "P15" definitions deleted	23642
		Figure 3(d)	: Arrowhead added to $\bar{Q}15$ output control line	23642
		Para. 4.2.2	: PIND deviation deleted, "None" added	21048
		Para. 4.2.4	: Deviation deleted, "None" added	22919
		Para. 4.2.5	: Deviation deleted, "None" added	22919
		Para. 4.3.2	: FP/DIP weights amended	221047
			: Weight for CCP added	221106
		Para. 4.4.2	: Paragraph rewritten	221106
		Para. 4.5.2	: Paragraph rewritten	221106
		Para. 4.5.3	: Paragraph standardised	23519
		Para. 4.6.3	: "...and functional test sequence..." deleted	23519
		Para. 4.7.1	: "T _{amb} " added before "... + 22 ± 3°C"	23519
		Paras. 4.7.2 & 4.7.3	: In title and paragraph, "burn-in" amended to read "power burn-in"	23519
		Figure 4(i)	: Note 4 amended and renumbered as 1	23573
		Para. 4.8	: Title amended	23519

**TABLE OF CONTENTS**

	<u>Page</u>
1. <u>GENERAL</u>	5
1.1 Scope	5
1.2 Component Type Variants	5
1.3 Maximum Ratings	5
1.4 Parameter Derating Information	5
1.5 Physical Dimensions	5
1.6 Pin Assignment	5
1.7 Truth Table	5
1.8 Circuit Schematic	5
1.9 Functional Diagram	5
2. <u>APPLICABLE DOCUMENTS</u>	16
3. <u>TERMS, DEFINITIONS, ABBREVIATIONS, SYMBOLS AND UNITS</u>	16
4. <u>REQUIREMENTS</u>	16
4.1 General	16
4.2 Deviations from Generic Specification	16
4.2.1 Deviations from Special In-process Controls	16
4.2.2 Deviations from Final Production Tests	16
4.2.3 Deviations from Burn-in Tests	16
4.2.4 Deviations from Qualification Tests	16
4.2.5 Deviations from Lot Acceptance Tests	16
4.3 Mechanical Requirements	17
4.3.1 Dimension Check	17
4.3.2 Weight	17
4.4 Materials and Finishes	17
4.4.1 Case	17
4.4.2 Lead Material and Finish	17
4.5 Marking	17
4.5.1 General	17
4.5.2 Lead Identification	17
4.5.3 The SCC Component Number	18
4.5.4 Traceability Information	18
4.6 Electrical Measurements	18
4.6.1 Electrical Measurements at Room Temperature	18
4.6.2 Electrical Measurements at High and Low Temperatures	18
4.6.3 Circuits for Electrical Measurements	18
4.7 Burn-in Tests	18
4.7.1 Parameter Drift Values	18
4.7.2 Conditions for Power Burn-in	18
4.7.3 Electrical Circuits for Power Burn-in	18
4.8 Environmental and Endurance Tests	29
4.8.1 Electrical Measurements on Completion of Environmental Tests	29
4.8.2 Electrical Measurements at Intermediate Points during Endurance Tests	29
4.8.3 Electrical Measurements on Completion of Endurance Tests	29
4.8.4 Conditions for Operating Life Tests	29
4.8.5 Electrical Circuits for Operating Life Tests	29
4.8.6 Conditions for High Temperature Storage Test	29



Page

TABLES

1(a)	Type Variants	6
1(b)	Maximum Ratings	6
2	Electrical Measurements at Room Temperature, D.C. Parameters	19
	Electrical Measurements at Room Temperature, A.C. Parameters	21
3	Electrical Measurements at High and Low Temperatures	22
4	Parameter Drift Values	27
5	Conditions for Power Burn-in and Operating Life Test	27
6	Electrical Measurements on Completion of Environmental Tests and at Intermediate Points and on Completion of Endurance Tests	30

FIGURES

1	Not applicable	N/A
2	Physical Dimensions	7
3(a)	Pin Assignment	12
3(b)	Truth Table	13
3(c)	Circuit Schematic	14
3(d)	Functional Diagram	15
4	Circuits for Electrical Measurements	24
5	Electrical Circuit for Power Burn-in and Operating Life Test	28

APPENDICES (Applicable to specific Manufacturers only)

'A'	Agreed Deviations for Texas Instruments (F)	31
-----	---	----

**1. GENERAL****1.1 SCOPE**

This specification details the ratings, physical and electrical characteristics, test and inspection data for a silicon monolithic, low power bipolar Schottky 16-Bit Shift Register, based on Type 54LS673. It shall be read in conjunction with ESA/SCC Generic Specification No. 9000, the requirements of which are supplemented herein.

1.2 COMPONENT TYPE VARIANTS

Variants of the basic type integrated circuits specified herein, which are also covered by this specification, are given in Table 1(a).

1.3 MAXIMUM RATINGS

The maximum ratings, which shall not be exceeded at any time during use or storage, applicable to the integrated circuits specified herein, are as scheduled in Table 1(b).

1.4 PARAMETER DERATING INFORMATION (FIGURE 1)

Not applicable.

1.5 PHYSICAL DIMENSIONS

The physical dimensions of the integrated circuits specified herein are shown in Figure 2.

1.6 PIN ASSIGNMENT

As per Figure 3(a).

1.7 TRUTH TABLE

As per Figure 3(b).

1.8 CIRCUIT SCHEMATIC

As per Figure 3(c).

1.9 FUNCTIONAL DIAGRAM

As per Figure 3(d).



TABLE 1(a) - TYPE VARIANTS

VARIANT	CASE	FIGURE	LEAD MATERIAL AND/OR FINISH
01	FLAT	2(a)	D7
02	FLAT	2(a)	G4
05	DIL	2(b)	D7
06	DIL	2(b)	G4
07	DIL	2(c)	D7
08	DIL	2(c)	D3 or D4
11	CCP	2(d)	7
12	CCP	2(d)	4

TABLE 1(b) - MAXIMUM RATINGS

No.	CHARACTERISTICS	SYMBOL	MAXIMUM RATINGS	UNIT	REMARKS
1	Supply Voltage	V_{CC}	-0.5 to 7.0	V	-
2	Input Voltage	V_{IN}	-0.5 to 5.5	V	Note 1
3	Device Dissipation	P_D	440	mWdc	Note 2
4	Operating Temperature Range	T_{op}	-55 to +125	°C	-
5	Storage Temperature Range	T_{stg}	-65 to +150	°C	-
6	Soldering Temperature For FP and DIP For CCP	T_{sol}	+265 +245	°C	Note 3 Note 4

NOTES

1. Input current limited to -18mA.
2. Must withstand added P_D due to short circuit conditions (i.e. I_{OS}) at one output for 5 seconds.
3. Duration 10 seconds maximum at a distance of not less than 1.5mm from the device body and the same lead shall not be resoldered until 3 minutes have elapsed.
4. Duration 5 seconds maximum and the same terminal shall not be resoldered until 3 minutes have elapsed.

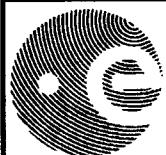
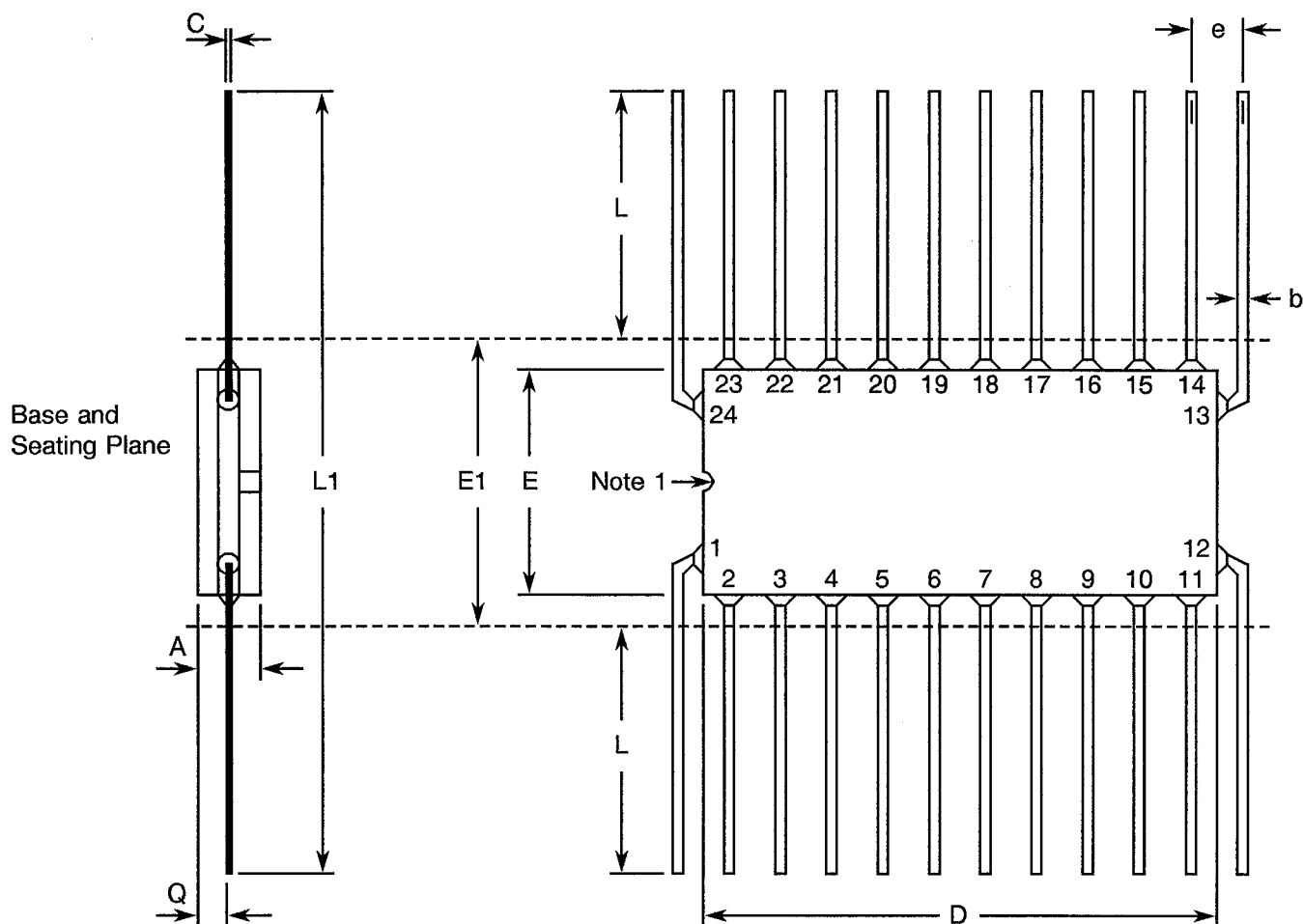


FIGURE 2 - PHYSICAL DIMENSIONS

FIGURE 2(a) - FLAT PACKAGE, 24-PIN



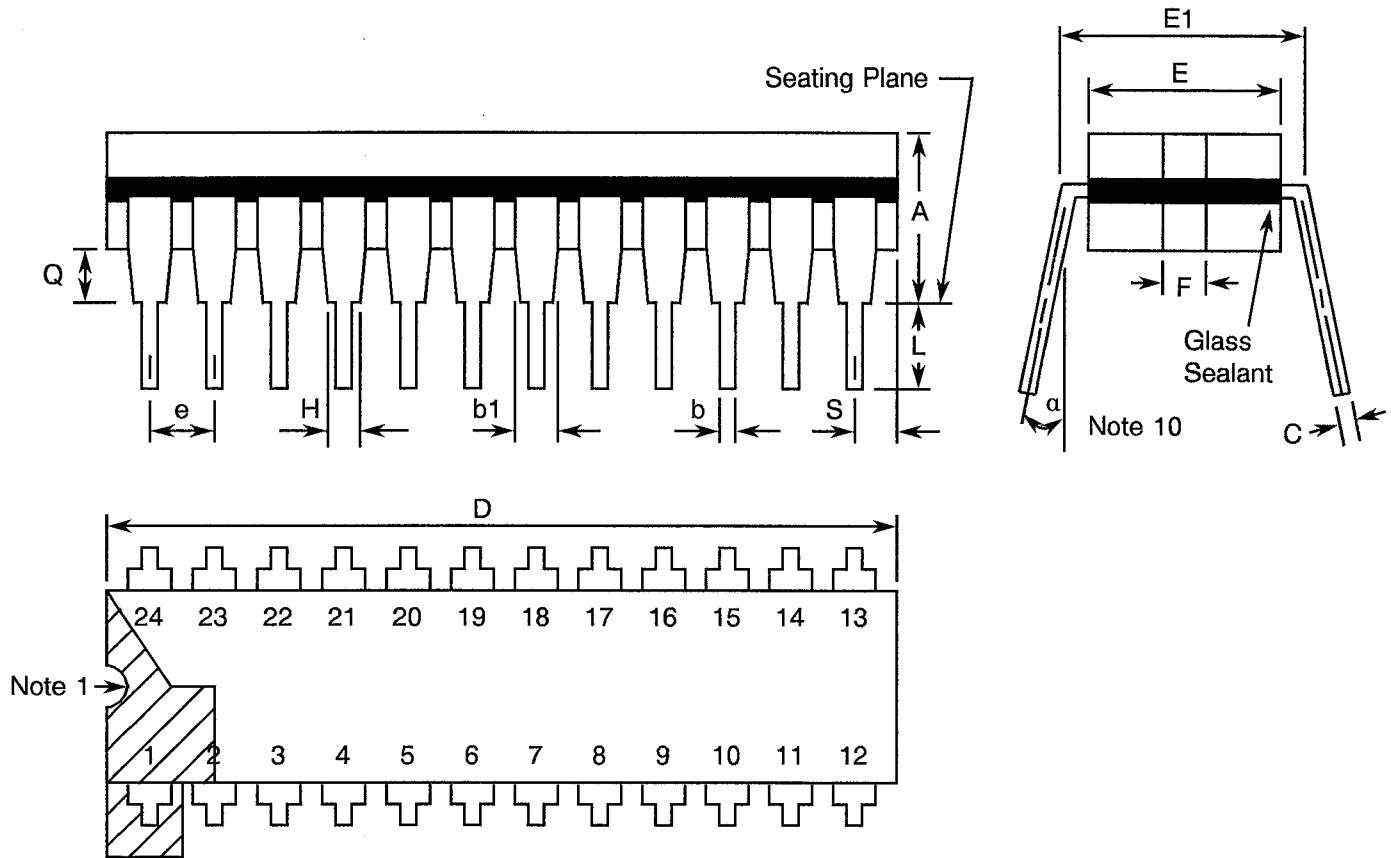
SYMBOL	MILLIMETRES		NOTES
	MIN	MAX	
A	1.39	2.16	
b	0.38	0.56	8
C	0.08	0.23	8
D	12.30	-	
E	8.50	10.10	
E1	10.16 TYPICAL		4
e	1.27 TYPICAL		5, 9
L	6.98	10.16	
L1	24.13	30.48	
Q	0.25	1.02	2

NOTES: See Page 11.



FIGURE 2 - PHYSICAL DIMENSIONS (CONTINUED)

FIGURE 2(b) - DUAL-IN-LINE PACKAGE, 24-PIN



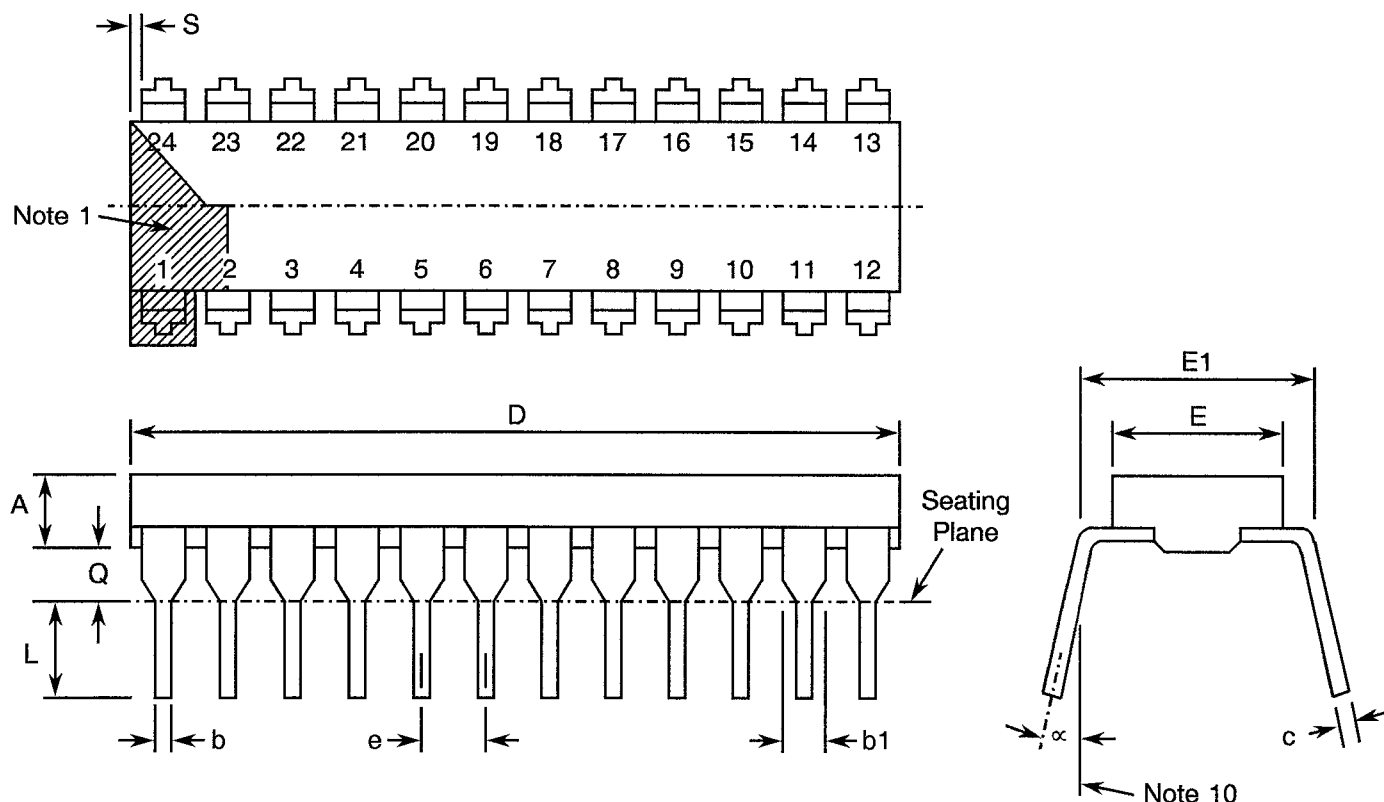
SYMBOL	MILLIMETRES		NOTES
	MIN	MAX	
A	3.80	5.70	
b	0.38	0.66	8
b1	-	1.78	8
C	0.20	0.44	8
D	31.40	32.80	4
E	13.10	14.20	4
E1	15.00	15.50	
e	2.54 TYPICAL		6, 9
F	1.27 TYPICAL		
H	0.69	-	8
L	3.18	5.08	8
Q	0.51	-	3
S	-	2.54	7
a	0°	15°	10

NOTES: See Page 11.



FIGURE 2 - PHYSICAL DIMENSIONS (CONTINUED)

FIGURE 2(c) - DUAL-IN-LINE PACKAGE, 24-PIN



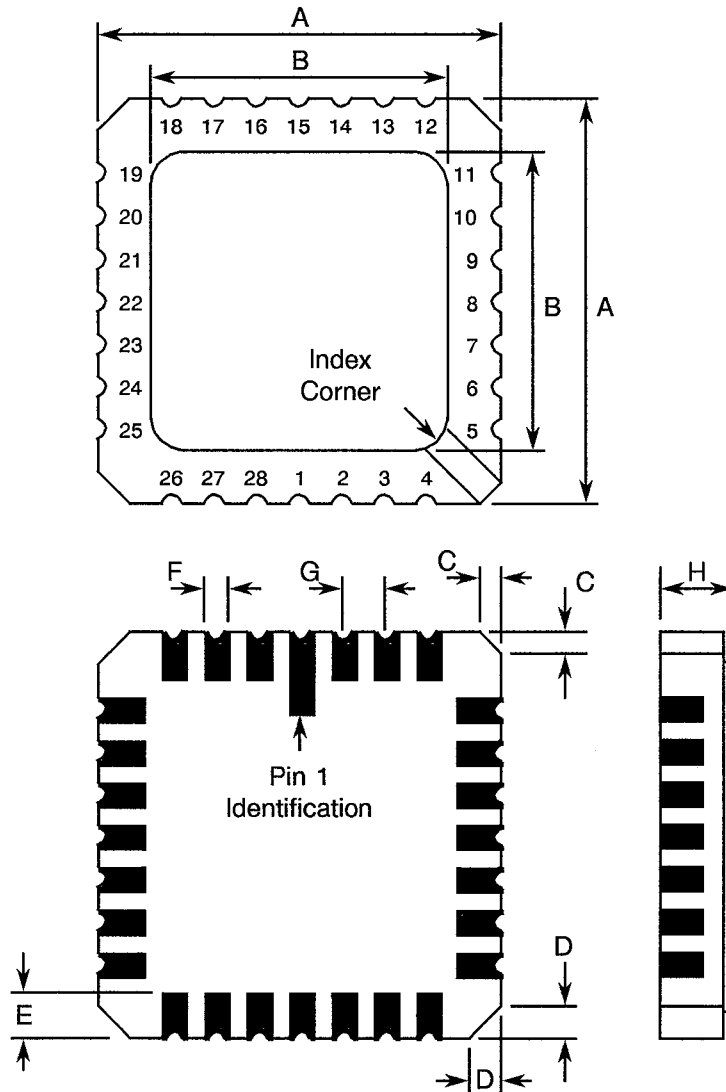
SYMBOL	MILLIMETRES		NOTES
	MIN.	MAX.	
A	-	5.08	-
b	0.38	0.58	8
b1	0.76	1.78	8
c	0.20	0.30	8
D	31.40	32.80	-
E	13.10	14.22	-
E1	15.00	15.50	4
e	2.54 TYPICAL		6, 9
L	3.18	5.08	-
Q	0.51	2.03	3
S	1.52	2.54	7
α	0°	15°	10

NOTES: See Page 11.



FIGURE 2 - PHYSICAL DIMENSIONS (CONTINUED)

FIGURE 2(d) - SQUARE CHIP CARRIER PACKAGE, 28-TERMINAL



SYMBOL	MILLIMETRES		NOTES
	MIN.	MAX.	
A	11.23	11.63	
B	10.31	11.63	
C	0.25	0.51	11
D	0.89	1.14	12
E	1.14	1.40	8
F	0.56	0.71	8
G	1.27 TYPICAL		5, 9
H	1.63	2.54	

NOTES: See Page 11.

**ESCC**ESA/SCC Detail Specification
No. 9306/035

PAGE 11

ISSUE 2

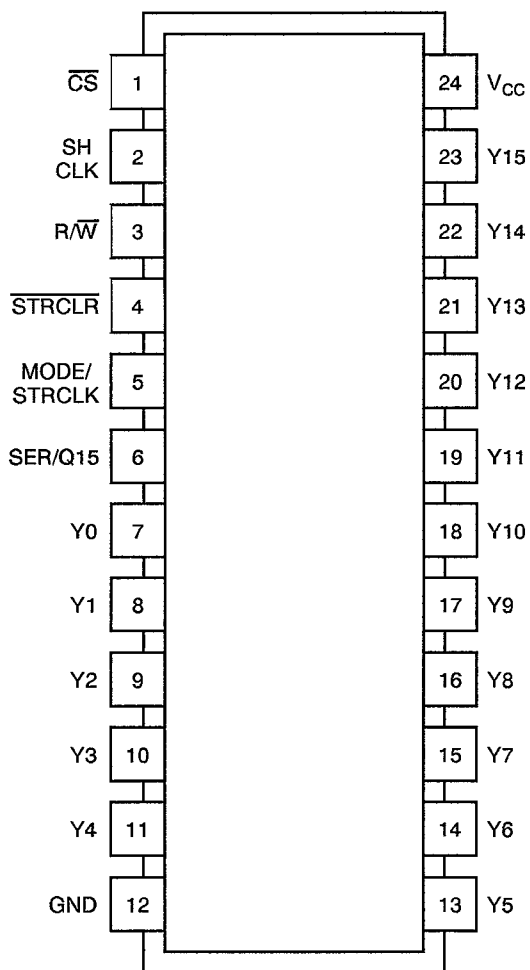
FIGURE 2 - PHYSICAL DIMENSIONS (CONTINUED)**NOTES TO FIGURES 2(a) TO 2(d)**

1. Index area: a notch or dot shall be located adjacent to Pin 1 and shall be within the shaded area shown. For chip carrier packages, the index shall be as shown in Figure 2(d).
2. Dimension Q shall be measured at the point of exit of the lead from the body.
3. Dimension Q shall be measured from the seating plane to the base plane.
4. This dimension allows for off-centre lids, meniscus and glass overrun.
5. The true position pin or terminal spacing is 1.27mm between centrelines. Each pin or terminal centreline shall be located within $\pm 0.13\text{mm}$ of its true longitudinal position relative to Pins 1 and the highest pin number.
6. The true position pin spacing is 2.54mm between centrelines. Each pin centreline shall be located within $\pm 0.25\text{mm}$ of its true longitudinal position relative to Pins 1 and the highest pin number.
7. Applies to all 4 corners.
8. All leads or terminals.
9. 22 spaces for flat and dual-in-line packages.
24 spaces for chip carrier packages.
10. Lead centre when α is 0° .
11. Index corner only - 2 dimensions.
12. 3 non-index corners - 6 dimensions.



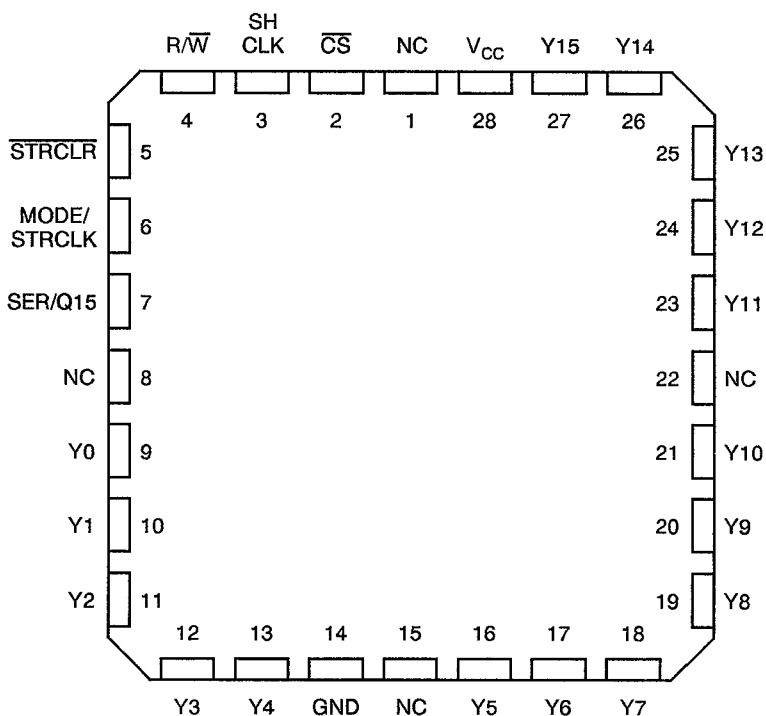
FIGURE 3(a) - PIN ASSIGNMENT

DUAL-IN-LINE AND FLAT PACKAGE



(TOP VIEW)

CHIP CARRIER PACKAGE



(TOP VIEW)

FLAT PACKAGE AND DUAL-IN-LINE TO CHIP CARRIER PIN ASSIGNMENT

FLAT PACKAGE AND

DUAL-IN-LINE PIN OUTS	1	2	3	4	5	6	7	8	9	10	11	12	13	14	15	16	17	18	19	20	21	22	23	24
-----------------------	---	---	---	---	---	---	---	---	---	----	----	----	----	----	----	----	----	----	----	----	----	----	----	----

CHIP CARRIER PIN OUTS	2	3	4	5	6	7	9	10	11	12	13	14	16	17	18	19	20	21	23	24	25	26	27	28
-----------------------	---	---	---	---	---	---	---	----	----	----	----	----	----	----	----	----	----	----	----	----	----	----	----	----

NOTES

1. All references throughout this specification relate to FLAT/DIL packages only.



FIGURE 3(b) - TRUTH TABLE

INPUTS					SER/ Q15	SHIFT REGISTER FUNCTIONS				STORAGE REGISTER FUNCTIONS	
\overline{CS}	$\overline{R\overline{W}}$	SH CLK	\overline{STRCLR}	MODE/ STRCLK		SHIFT	READ FROM SERIAL OUTPUT	WRITE INTO SERIAL INPUT	PARALLEL LOAD	CLEAR	LOAD
H	X	X	X	X	Z	NO	NO	NO	NO	-	NO
X	X	X	L	X	-	-	-	-	-	YES	-
L	L	↓	X	X	Z	YES	NO	YES	NO	-	-
L	H	X	X	X	Q15	-	YES	NO	-	-	NO
L	H	↓	X	L	Q14n	YES	YES	NO	NO	-	NO
L	H	↓	L	H	L	NO	YES	-	YES	YES	NO
L	H	↓	H	H	Y15n	NO	YES	-	YES	NO	NO
L	L	X	H	↑	Z	-	NO	-	NO	NO	YES

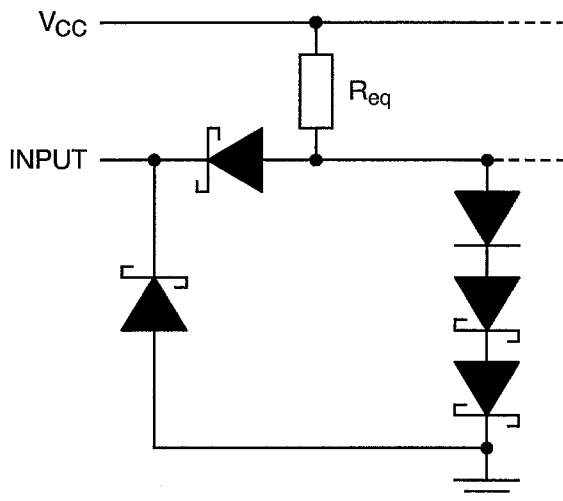
NOTES

1. Logic Level Definitions: L = Low Level, H = High Level, X = Don't Care, Z = High Impedance Input Mode.
2. ↑ = transition from low to high level, ↓ = transition from high to low level.
3. Q14n = content of 14th bit of the shift register before the most recent ↓ transition of the clock.
4. Q15 = present content of the 15th bit of the shift register.
5. Y15n = content of 15th bit of the storage register before the most recent ↓ transition of the clock.

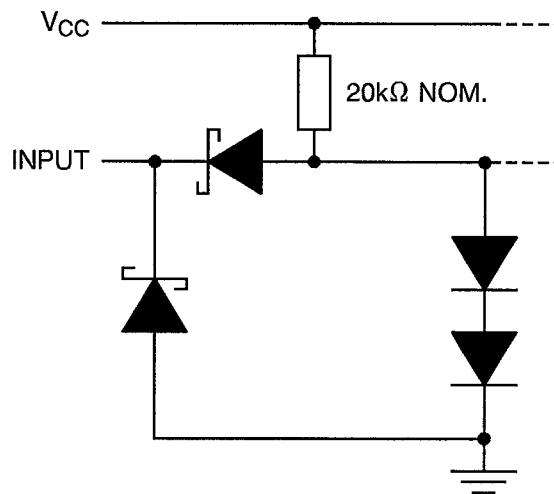


FIGURE 3(c) - CIRCUIT SCHEMATIC

EQUIVALENT OF SER/Q15
AND PARALLEL INPUTS



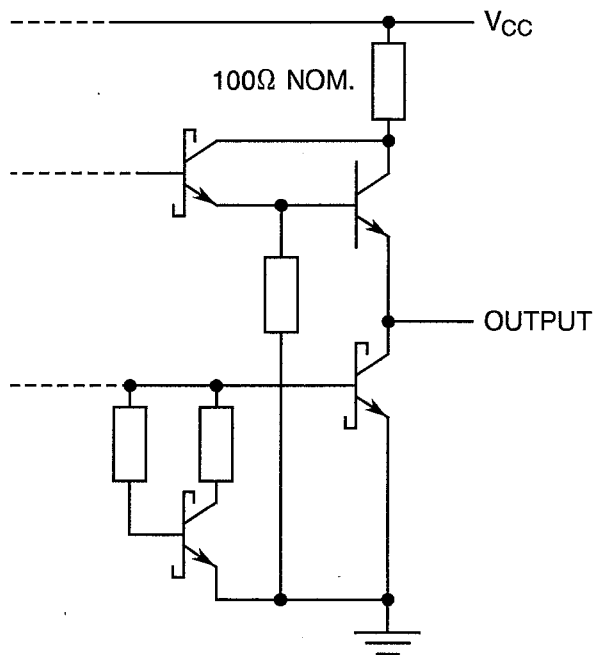
EQUIVALENT OF OTHER INPUTS



NOTES

- 1. SER/Q15: $R_{eq} = 20k\Omega$ NOM.
Parallel Inputs: $R_{eq} = 30k\Omega$ NOM.

SER/Q15 OUTPUT



TYPICAL OF Y0 THRU Y15 OUTPUTS

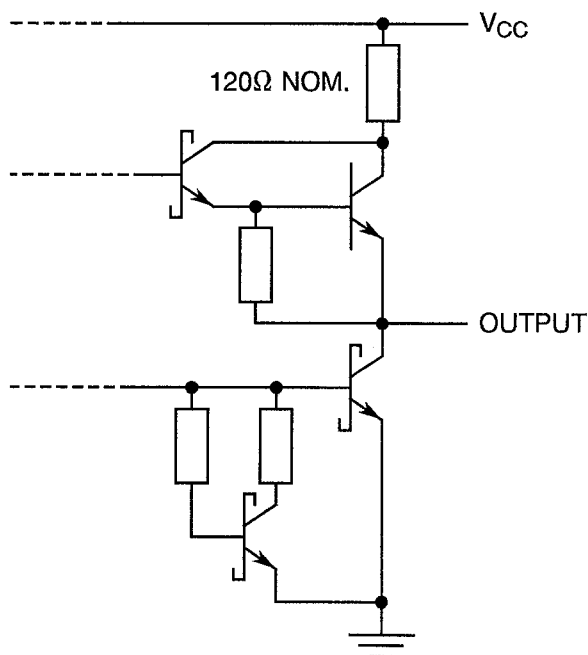
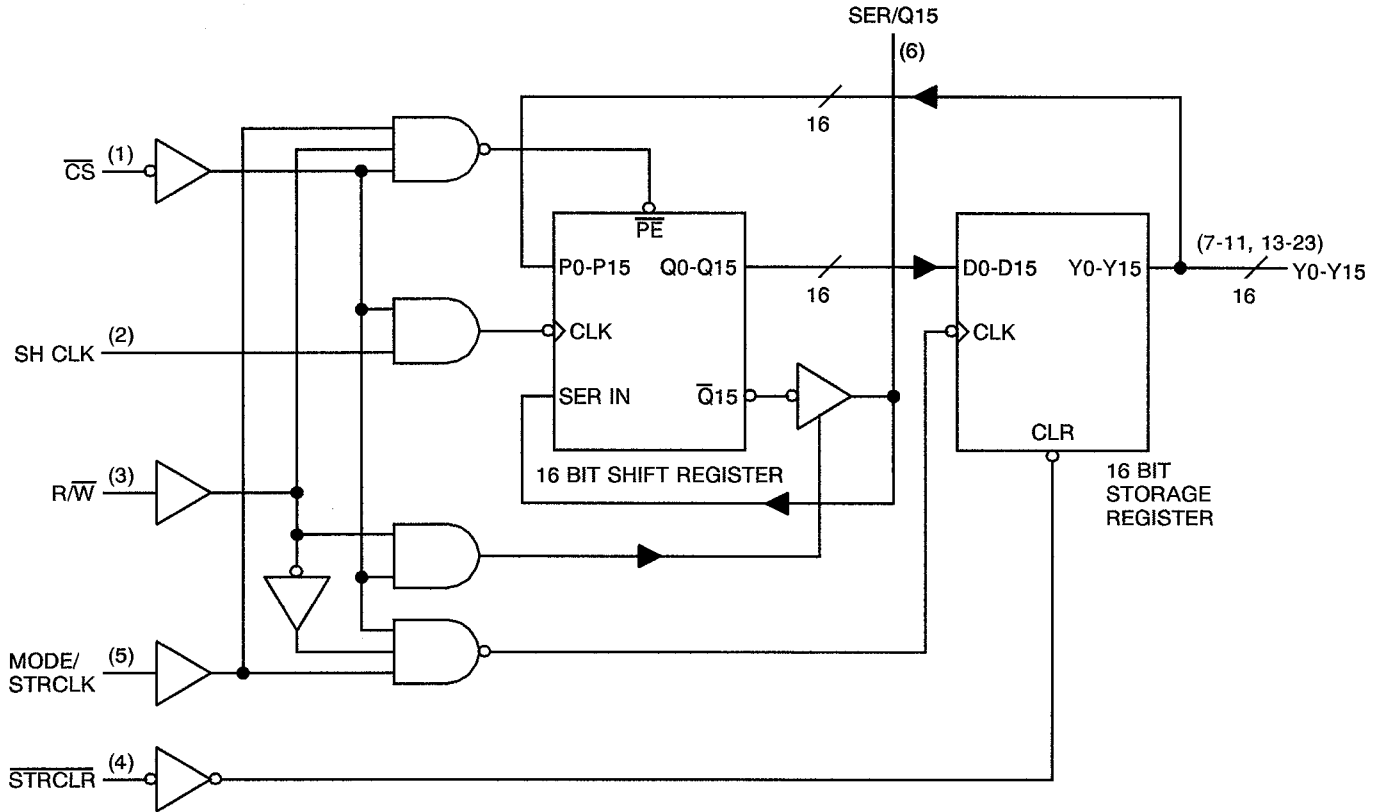




FIGURE 3(d) - FUNCTIONAL DIAGRAM



**2. APPLICABLE DOCUMENTS**

The following documents form part of this specification and shall be read in conjunction with it:-

- (a) ESA/SCC Generic Specification No. 9000 for Integrated Circuits.
- (b) MIL-STD-883, Test Methods and Procedures for Micro-electronics.

3. TERMS, DEFINITIONS, ABBREVIATIONS, SYMBOLS AND UNITS

For the purpose of this specification, the terms, definitions, abbreviations, symbols and units specified in ESA/SCC Basic Specification No. 21300 shall apply. In addition, the following abbreviations are used:-

- V_{IC} = Input Clamp Voltage.
- V_{CC} = Supply Voltage.
- I_{OZH} = Off-State Current, Outputs High.
- I_{OZL} = Off-State Current, Outputs Low.

4. REQUIREMENTS**4.1 GENERAL**

The complete requirements for procurement of the integrated circuits specified herein are stated in this specification and ESA/SCC Generic Specification No. 9000 for Integrated Circuits. Deviations from the Generic Specification applicable to this specification only, are listed in Para. 4.2.

Deviations from the applicable Generic Specification and this Detail Specification, formally agreed with specific Manufacturers on the basis that the alternative requirements are equivalent to the ESA/SCC requirements and do not affect the components' reliability, are listed in the appendices attached to this specification.

4.2 DEVIATIONS FROM GENERIC SPECIFICATION**4.2.1 Deviations from Special In-process Controls**

None.

4.2.2 Deviations from Final Production Tests (Chart II)

None.

4.2.3 Deviations from Burn-in Tests (Chart III)

- (a) Para. 7.1.1(a), "High Temperature Reverse Bias" test and subsequent electrical measurements related to this test shall be omitted.
- (b) Para. 9.9.2, "Electrical Measurements at High and Low Temperatures": Only a test result summary, based on go-no-go tests and presented in histogram form is required.

4.2.4 Deviations from Qualification Tests (Chart IV)

None.

4.2.5 Deviations from Lot Acceptance Tests (Chart V)

None.



4.3 MECHANICAL REQUIREMENTS

4.3.1 Dimension Check

The dimensions of the integrated circuits specified herein shall be checked. They shall conform to those shown in Figure 2.

4.3.2 Weight

The maximum weight of the integrated circuits specified herein shall be 1.2 grammes for the flat package, 8.0 grammes for the dual-in-line package and 0.8 grammes for the chip carrier package.

4.4 MATERIALS AND FINISHES

The materials and finishes shall be as specified herein. Where a definite material is not specified, a material which will enable the integrated circuits specified herein to meet the performance requirements of this specification shall be used. Acceptance or approval of any constituent material does not guarantee acceptance of the finished product.

4.4.1 Case

The case shall be hermetically sealed and have a metal body with hard glass seals or a ceramic body and the lids shall be welded, brazed, preform-soldered or glass frit-sealed.

4.4.2 Lead Material and Finish

For dual-in-line and flat packages, the material shall be either Type 'D' or Type 'G' with either Type '3 or 4', Type '4' or Type '7' finish in accordance with the requirements of ESA/SCC Basic Specification No. 23500. For chip carrier packages, the finish shall be either Type '4' or Type '7' in accordance with the requirements of ESA/SCC Basic Specification No. 23500. (See Table 1(a) for Type Variants).

4.5 MARKING

4.5.1 General

The marking of all components delivered to this specification shall be in accordance with the requirements of ESA/SCC Basic Specification No. 21700. Each component shall be marked in respect of:-

- (a) Lead Identification.
- (b) The SCC Component Number.
- (c) Traceability Information.

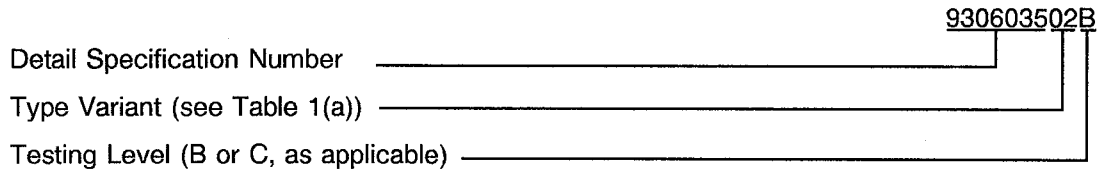
4.5.2 Lead Identification

For dual-in-line and flat packages, an index shall be located at the top of the package in the position defined in Note 1 to Figure 2 or, alternatively, a tab may be used to identify Pin No. 1. The pin numbering must be read with the index or tab on the left-hand side. For chip carrier packages, the index shall be as defined by Figure 2(d).



4.5.3 The SCC Component Number

Each component shall bear the SCC Component Number which shall be constituted and marked as follows:



4.5.4 Traceability Information

Each component shall be marked in respect of traceability information in accordance with the requirements of ESA/SCC Basic Specification No. 21700.

4.6 ELECTRICAL MEASUREMENTS

4.6.1 Electrical Measurements at Room Temperature

The parameters to be measured in respect of electrical characteristics are scheduled in Table 2. Unless otherwise specified, the measurements shall be performed at $T_{amb} = +22 \pm 3 \text{ }^\circ\text{C}$.

4.6.2 Electrical Measurements at High and Low Temperatures

The parameters to be measured at high and low temperatures are scheduled in Table 3. The measurements shall be performed at $T_{amb} = +125^\circ\text{C}$ and -55°C respectively.

4.6.3 Circuits for Electrical Measurements

Circuits for use in performing the electrical measurements listed in Tables 2 and 3 of this specification are shown in Figure 4.

4.7 BURN-IN TESTS

4.7.1 Parameter Drift Values

The parameter drift values applicable to burn-in are specified in Table 4 of this specification. Unless otherwise stated, measurements shall be performed at $T_{amb} = +22 \pm 3 \text{ }^\circ\text{C}$. The parameter drift values (Δ) applicable to the parameters scheduled, shall not be exceeded. In addition to these drift value requirements, the appropriate limit value specified for a given parameter in Table 2 shall not be exceeded.

4.7.2 Conditions for Power Burn-in

The requirements for power burn-in are specified in Section 7 of ESA/SCC Generic Specification No. 9000. The conditions for power burn-in shall be as specified in Table 5 of this specification.

4.7.3 Electrical Circuits for Power Burn-in

Circuits for use in performing the power burn-in tests are shown in Figure 5 of this specification.



TABLE 2 - ELECTRICAL MEASUREMENTS AT ROOM TEMPERATURE - D.C. PARAMETERS

No.	CHARACTERISTICS	SYMBOL	TEST METHOD MIL-STD 883	TEST FIG.	TEST CONDITIONS (PINS UNDER TEST)	LIMITS		UNIT
						MIN	MAX	
1	Functional Test	-	-	3(b)	Verify Truth Table with Load. $V_{CC} = 5.0V$ Note 1	-	-	-
2	Input Current High Level 1 SER/Q15	I_{IH1}	3010	4(a)	$V_{CC} = 5.5V, V_{IN} = 2.7V$ (Pin 6)	-	40	μA
3 to 7	Input Current High Level 2 Other Inputs	I_{IH2}	3010	4(a)	$V_{CC} = 5.5V, V_{IN} = 2.7V$ (Pins 1-2-3-4-5)	-	20	μA
8	Input Current High Level 3 SER/Q15 (Max. Input Voltage)	I_{IH3}	3010	4(a)	$V_{CC} = 5.5V, V_{IN} = 5.5V$ (Pin 6)	-	100	μA
9 to 13	Input Current High Level 4 Other Inputs (Max. Input Voltage)	I_{IH4}	3010	4(a)	$V_{CC} = 5.5V, V_{IN} = 7.0V$ (Pins 1-2-3-4-5)	-	100	μA
14	Off-State Output Current, High Level Output	I_{OZH}	3007	4(h)	$V_{CC} = 5.5V, V_{IL} = 0.7V, V_{IH} = 2.0V, V_{OUT} = 2.7V$ (Pin 6)	-	40	μA
15	Off-State Output Current, Low Level Output	I_{OZL}	3007	4(h)	$V_{CC} = 5.5V, V_{IL} = 0.7V, V_{IH} = 2.0V, V_{OUT} = 0.4V$ (Pin 6)	-	-400	μA
16 to 20	Input Clamp Voltage	V_{IC}	3009	4(b)	$V_{IN} = 4.5V, I_{IN} = -18mA$ Note 2 (Pins 1-2-3-4-5)	-	-1.5	V
21 to 25	Input Current Low Level	I_{IL}	3009	4(c)	$V_{CC} = 5.5V, V_{IN} = 0.4V$ (Pins 1-2-3-4-5)	-	-0.4	mA
26	Output Voltage Low Level 1	V_{OL1}	3007	4(d)	$V_{CC} = 5.5V, V_{IL} = 0.7V, V_{IH} = 2.0V, I_{OL} = 12mA$ (Pin 6)	-	0.4	V
27 to 42	Output Voltage Low Level 2	V_{OL2}	3007	4(d)	$V_{CC} = 4.5V, V_{IL} = 0.7V, V_{IH} = 2.0V, I_{OL} = 4.0mA$ (Pins 7-8-9-10-11-13-14-15-16-17-18-19-20-21-22-23)	-	0.4	V

NOTES: See Page 20.



TABLE 2 - ELECTRICAL MEASUREMENTS AT ROOM TEMPERATURE - D.C. PARAMETERS (CONT'D)

No.	CHARACTERISTICS	SYMBOL	TEST METHOD MIL-STD 883	TEST FIG.	TEST CONDITIONS (PINS UNDER TEST)	LIMITS		UNIT
						MIN	MAX	
43	Output Voltage High Level 1	V_{OH1}	3006	4(e)	$V_{CC} = 5.5V$, $V_{IL} = 0.7V$, $V_{IH} = 2.0V$, $I_{OH} = -1.0mA$ (Pin 6)	2.4	-	V
44 to 59	Output Voltage High Level 2	V_{OH2}	3006	4(e)	$V_{CC} = 5.5V$, $V_{IL} = 0.7V$, $V_{IH} = 2.0V$, $I_{OH} = -400\mu A$ (Pins 7-8-9-10-11-13-14-15-16-17-18-19-20-21-22-23)	2.5	-	V
60 to 75	Short Circuit Output Current 1	I_{OS1}	3011	4(f)	$V_{CC} = 5.5V$ Note 3 (Pins 7-8-9-10-11-13-14-15-16-17-18-19-20-21-22-23)	-20	-100	mA
76	Short Circuit Output Current 2	I_{OS2}	3011	4(f)	$V_{CC} = 5.5V$ (Pin 6)	-30	-130	mA
77	Supply Current	I_{CC}	3005	4(g)	$V_{CC} = 5.5V$ (Pin 24)	-	80	mA

NOTES

1. Go-no-go test with $V_{IL} = 0.3V$; $V_{IH} = 3.0V$; trip point 1.3V.
2. All inputs and outputs not under test shall be open.
3. No more than one output should be shorted at a time, and only for 1 second maximum. I_{OS} measurement may be performed with $V_{OUT} = 2.25V$ instead of 0V. In this case the limits are divided by 2.
4. Propagation delay measurements shall be performed as a go-no-go test on a 100% basis. Read-and-record measurements shall be performed on an LTPD7 sample basis following the Chart III Burn-in Test.



TABLE 2 - ELECTRICAL MEASUREMENTS AT ROOM TEMPERATURE - A.C. PARAMETERS

No.	CHARACTERISTICS	SYMBOL	TEST METHOD MIL-STD 883	TEST FIG.	TEST CONDITIONS (PINS UNDER TEST) (NOTE 4)	LIMITS		UNIT
						MIN	MAX	
78 to 93	Propagation Delay, High to Low Level, from STRCLR to Y0-Y15	t _{PHL}	3003	4(i)	V _{CC} = 5.0V R _L = 2.0kΩ C _L = 15pF Pins 4 to 7 4 to 8 4 to 9 4 to 10 4 to 11 4 to 13 4 to 14 4 to 15 4 to 16 4 to 17 4 to 18 4 to 19 4 to 20 4 to 21 4 to 22 4 to 23		40	ns
94 to 109	Propagation Delay, High to Low Level, from Mode/STRCLK to Y0-Y15	t _{PHL}	3003	4(i)	V _{CC} = 5.0V R _L = 2.0kΩ C _L = 15pF Pins 5 to 7 5 to 8 5 to 9 5 to 10 5 to 11 5 to 13 5 to 14 5 to 15 5 to 16 5 to 17 5 to 18 5 to 19 5 to 20 5 to 21 5 to 22 5 to 23	-	45	ns
110 to 125	Propagation Delay, Low to High Level, from Mode/STRCLK to Y0-Y15	t _{PLH}				-	45	
126	Propagation Delay, Low to High Level, from SH CLK to SER/Q15	t _{PLH}	3003	4(i)	V _{CC} = 5.0V R _L = 667Ω C _L = 15pF Pins 2 to 6	-	33	ns
127	Propagation Delay, High to Low Level, from SH CLK to SER/Q15	t _{PHL}				-	40	
128 to 129	Output Enable Time to High Level, from CS and R/W	t _{PZH}	3003	4(i)	V _{CC} = 5.0V R _L = 667Ω C _L = 15pF Pins 1 to 6 3 to 6	-	45	ns
130 to 131	Output Enable Time to Low Level, from CS and R/W	t _{PZL}				-	45	
132 to 133	Output Disable Time from High Level, from CS and R/W	t _{PHZ}	3003	4(i)	V _{CC} = 5.0V R _L = 667Ω C _L = 15pF Pins 1 to 6 3 to 6	-	40	ns
134 to 135	Output Disable Time from Low Level, from CS and R/W	t _{PLZ}				-	40	

NOTES: See Page 20.

**TABLE 3 - ELECTRICAL MEASUREMENTS AT HIGH AND LOW TEMPERATURES,
+125(+0-5) °C AND -55(+5-0) °C**

No.	CHARACTERISTICS	SYMBOL	TEST METHOD MIL-STD 883	TEST FIG.	TEST CONDITIONS (PINS UNDER TEST)	LIMITS		UNIT
						MIN	MAX	
1	Functional Test	-	-	3(b)	Verify Truth Table with Load. $V_{CC} = 5.0V$ Note 1	-	-	-
2	Input Current High Level 1 SER/Q15	I_{IH1}	3010	4(a)	$V_{CC} = 5.5V$, $V_{IN} = 2.7V$ (Pin 6)	-	40	μA
3 to 7	Input Current High Level 2 Other Inputs	I_{IH2}	3010	4(a)	$V_{CC} = 5.5V$, $V_{IN} = 2.7V$ (Pins 1-2-3-4-5)	-	20	μA
8	Input Current High Level 3 SER/Q15 (Max. Input Voltage)	I_{IH3}	3010	4(a)	$V_{CC} = 5.5V$, $V_{IN} = 5.5V$ (Pin 6)	-	100	μA
9 to 13	Input Current High Level 4 Other Inputs (Max. Input Voltage)	I_{IH4}	3010	4(a)	$V_{CC} = 5.5V$, $V_{IN} = 7.0V$ (Pins 1-2-3-4-5)	-	100	μA
14	Off-State Output Current, High Level Output	I_{OZH}	3007	4(h)	$V_{CC} = 5.5V$, $V_{IL} = 0.7V$, $V_{IH} = 2.0V$, $V_{OUT} = 2.7V$ (Pin 6)	-	40	μA
15	Off-State Output Current, Low Level Output	I_{OZL}	3007	4(h)	$V_{CC} = 5.5V$, $V_{IL} = 0.7V$, $V_{IH} = 2.0V$, $V_{OUT} = 0.4V$ (Pin 6)	-	-400	μA
16 to 20	Input Clamp Voltage	V_{IC}	3009	4(b)	$V_{IN} = 4.5V$, $I_{IN} = -18mA$ Note 2 (Pins 1-2-3-4-5)	-	-1.5	V
21 to 25	Input Current Low Level	I_{IL}	3009	4(c)	$V_{CC} = 5.5V$, $V_{IN} = 0.4V$ (Pins 1-2-3-4-5)	-	-0.4	mA
26	Output Voltage Low Level 1	V_{OL1}	3007	4(d)	$V_{CC} = 5.5V$, $V_{IL} = 0.7V$, $V_{IH} = 2.0V$, $I_{OL} = 12mA$ (Pin 6)	-	0.4	V
27 to 42	Output Voltage Low Level 2	V_{OL2}	3007	4(d)	$V_{CC} = 4.5V$, $V_{IL} = 0.7V$, $V_{IH} = 2.0V$, $I_{OL} = 4.0mA$ (Pins 7-8-9-10-11-13-14-15-16-17-18-19-20-21-22-23)	-	0.4	V

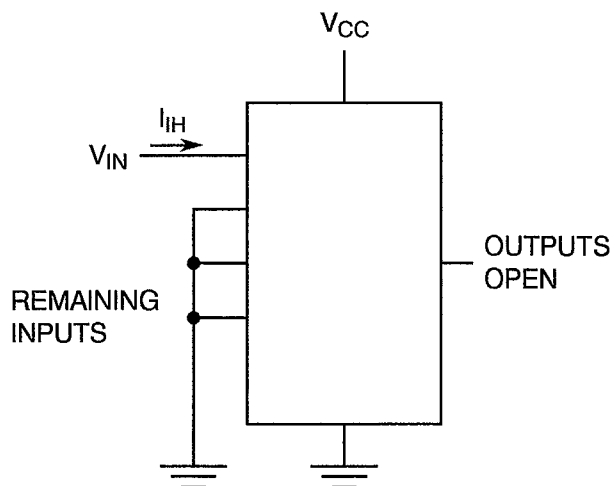
NOTES: See Page 20.



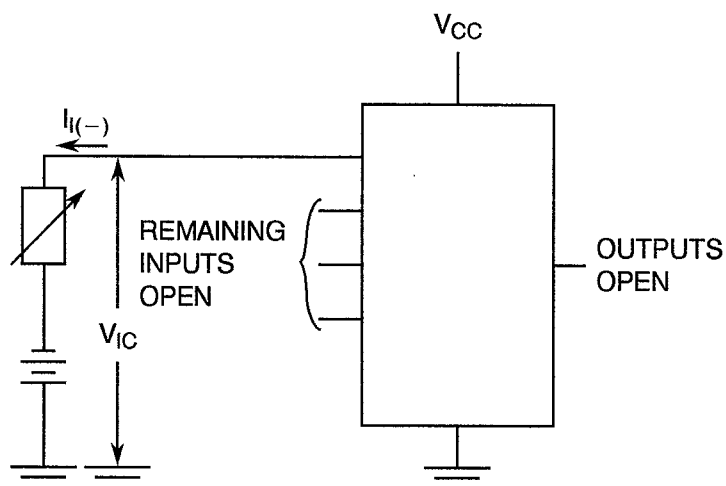
**TABLE 3 - ELECTRICAL MEASUREMENTS AT HIGH AND LOW TEMPERATURES,
+ 125(+ 0 - 5) °C AND - 55(+ 5 - 0) °C (CONT'D)**

No.	CHARACTERISTICS	SYMBOL	TEST METHOD MIL-STD 883	TEST FIG.	TEST CONDITIONS (PINS UNDER TEST)	LIMITS		UNIT
						MIN	MAX	
43	Output Voltage High Level 1	V _{OH1}	3006	4(e)	V _{CC} = 5.5V, V _{IL} = 0.7V, V _{IH} = 2.0V, I _{OH} = -1.0mA (Pin 6)	2.4	-	V
44 to 59	Output Voltage High Level 2	V _{OH2}	3006	4(e)	V _{CC} = 5.5V, V _{IL} = 0.7V, V _{IH} = 2.0V, I _{OH} = -400µA (Pins 7-8-9-10-11-13-14-15-16-17-18-19-20-21-22-23)	2.5	-	V
60 to 75	Short Circuit Output Current 1	I _{OS1}	3011	4(f)	V _{CC} = 5.5V Note 3 (Pins 7-8-9-10-11-13-14-15-16-17-18-19-20-21-22-23)	-20	-100	mA
76	Short Circuit Output Current 2	I _{OS2}	3011	4(f)	V _{CC} = 5.5V (Pin 6)	-30	-130	mA
77	Supply Current	I _{CC}	3005	4(g)	V _{CC} = 5.5V (Pin 24)	-	80	mA

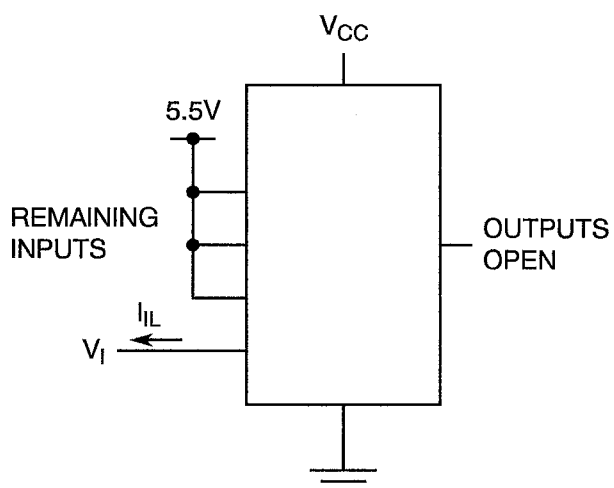
NOTES: See Page 20.

FIGURE 4 - CIRCUITS FOR ELECTRICAL MEASUREMENTS
FIGURE 4(a) - HIGH LEVEL INPUT CURRENT

NOTES

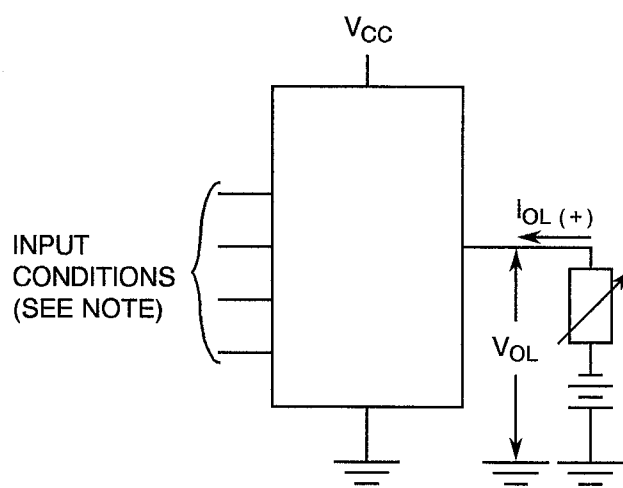
1. Each input to be tested separately.

FIGURE 4(b) - INPUT CLAMP VOLTAGE

NOTES

1. Each input to be tested separately.

FIGURE 4(c) - LOW LEVEL INPUT CURRENT

NOTES

1. Each input to be tested separately.

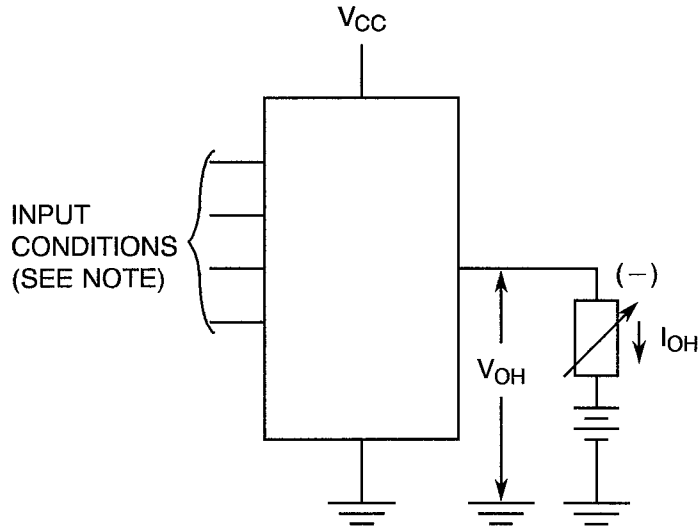
FIGURE 4(d) - LOW LEVEL OUTPUT VOLTAGE

NOTES

1. Test per Truth Table.



FIGURE 4 - CIRCUITS FOR ELECTRICAL MEASUREMENTS (CONTINUED)

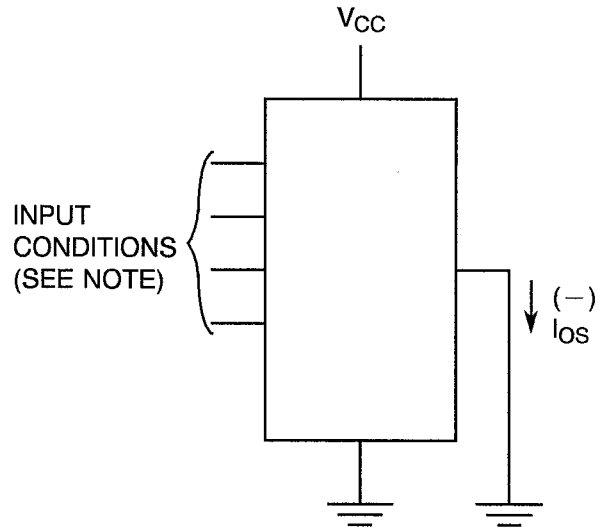
FIGURE 4(e) - HIGH LEVEL OUTPUT VOLTAGE



NOTES

1. Test per Truth Table.

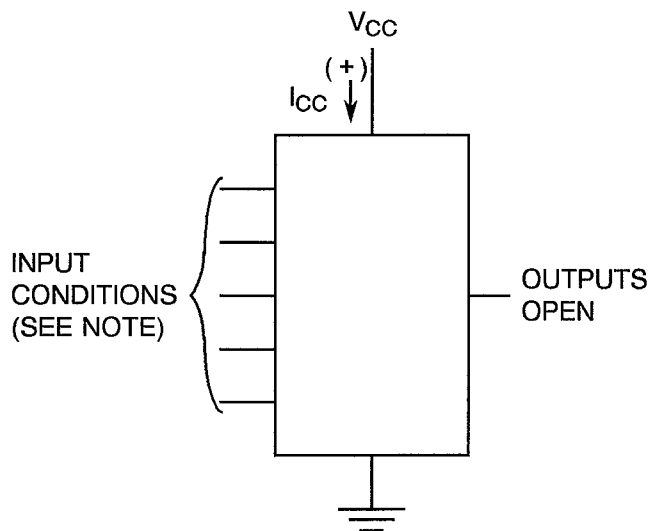
FIGURE 4(f) - SHORT CIRCUIT OUTPUT CURRENT



NOTES

1. Test per Truth Table.

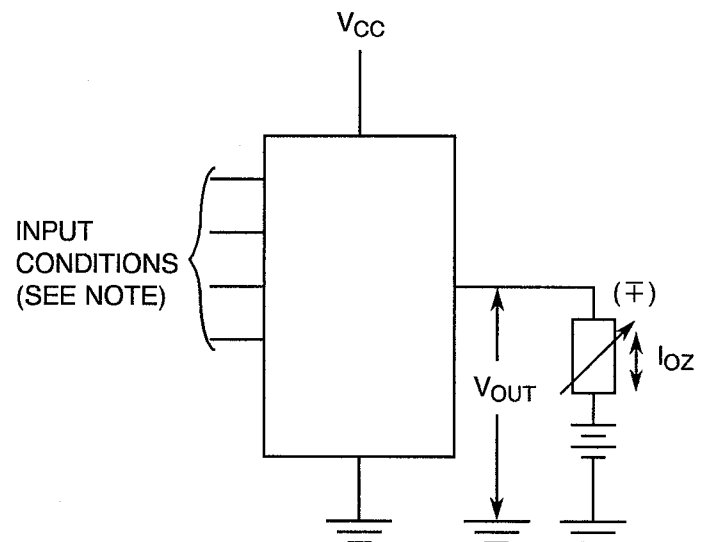
FIGURE 4(g) - SUPPLY CURRENT



NOTES

1. All inputs at ground.

FIGURE 4(h) - OFF-STATE OUTPUT CURRENT



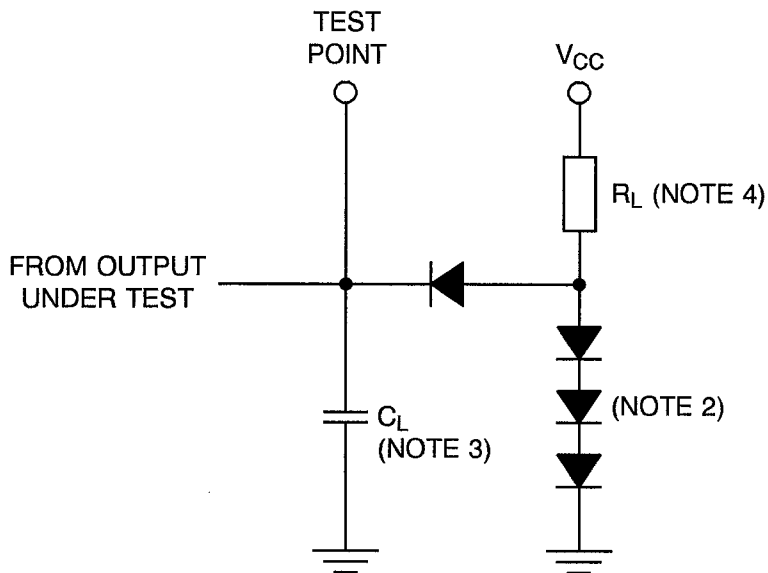
NOTES

1. Test per Truth Table.

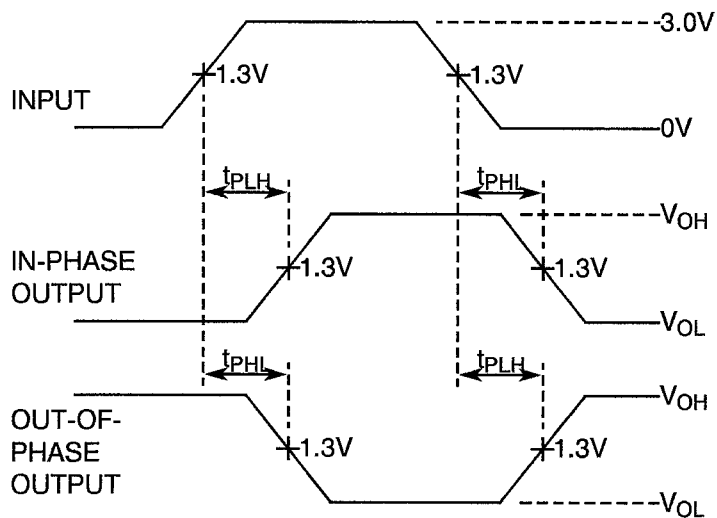


FIGURE 4 - CIRCUITS FOR ELECTRICAL MEASUREMENTS (CONTINUED)

FIGURE 4(i) - DYNAMIC TEST AND SWITCHING WAVEFORMS



VOLTAGE WAVEFORMS



NOTES

1. The generator has the following characteristics: $V_{GEN} = 3.0 \pm 0.2V$, $t_r \leq 6.0ns$, $t_f \leq 15ns$, $t_p = 0.5\mu s$, $PRR = 1.0MHz$, $Z_{OUT} = 50\Omega$.
2. All diodes are 1N916 or 1N3064.
3. $C_L = 15pF \pm 15\%$ including scope probe, wiring and stray capacitance without package in test fixture.
4. $R_L = 2.0k\Omega \pm 5\%$ or $667\Omega \pm 15\%$.

**TABLE 4 - PARAMETER DRIFT VALUES**

No.	CHARACTERISTICS	SYMBOL	SPEC. AND/OR TEST METHOD	TEST CONDITIONS	CHANGE LIMITS (Δ)	UNIT
2	Input Current High Level 1	I_{IH1}	As per Table 2	As per Table 2	± 0.5 or (1) ± 20	μA %
21 to 25	Input Current Low Level	I_{IL}	As per Table 2	As per Table 2	± 18	μA
26	Output Voltage Low Level 1	V_{OL1}	As per Table 2	As per Table 2	± 60	mV
27 to 42	Output Voltage Low Level 2	V_{OL2}	As per Table 2	As per Table 2	± 60	mV
43	Output Voltage High Level 1	V_{OH1}	As per Table 2	As per Table 2	± 240	mV
44 to 59	Output Voltage High Level 2	V_{OH2}	As per Table 2	As per Table 2	± 240	mV

NOTES

1. Whichever is greater, referred to the initial value.

TABLE 5 - CONDITIONS FOR POWER BURN-IN AND OPERATING LIFE TEST

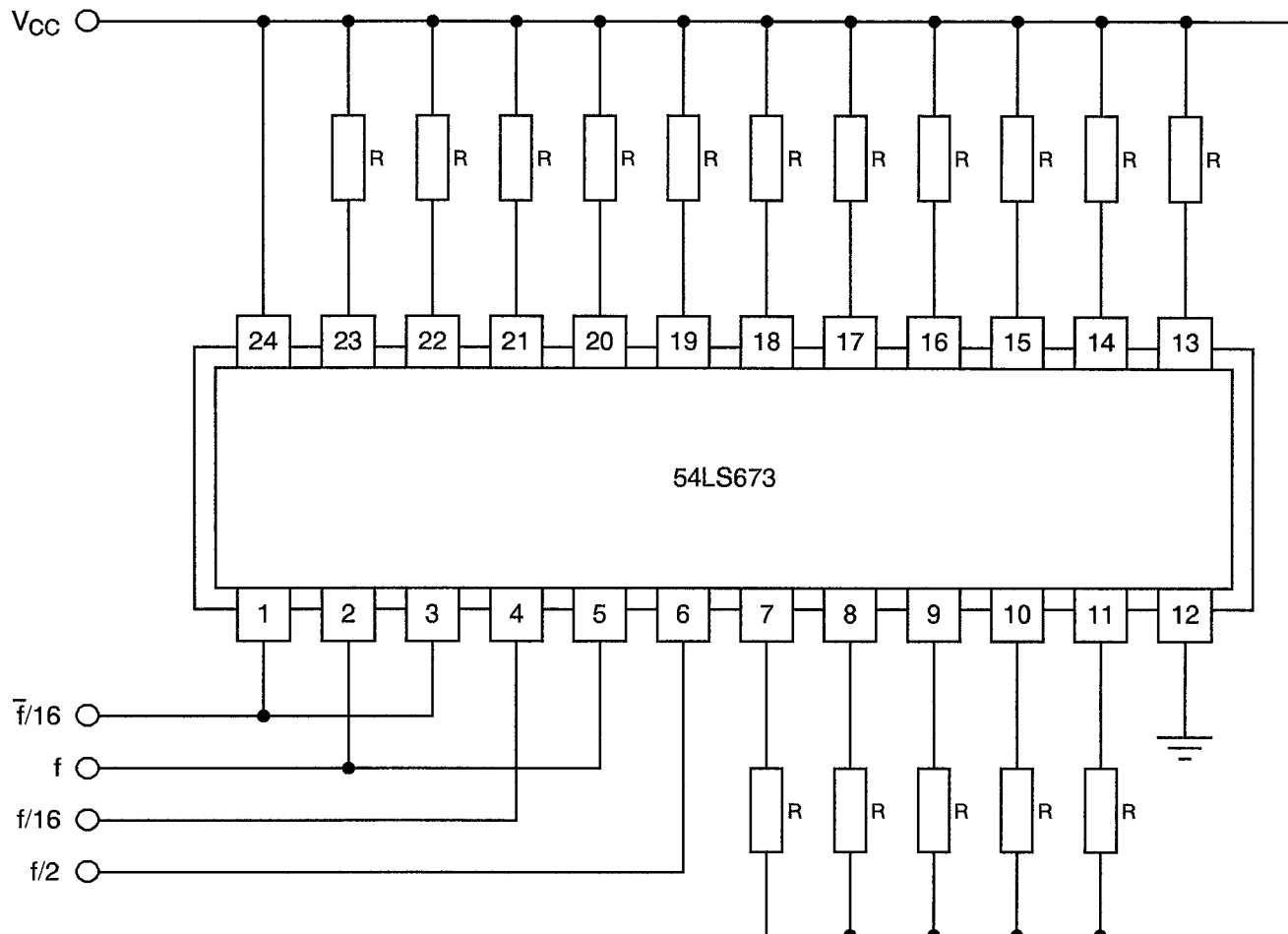
No.	CHARACTERISTICS	SYMBOL	CONDITION	UNIT
1	Ambient Temperature	T_{amb}	+ 125(+ 0 - 5)	$^{\circ}C$
2	Power Supply Voltage	V_{CC}	+ 5(+ 0.5 - 0)	V
3	Pulse Voltage	V_{GEN}	0.5 max. to 3.0 min.	V
4	Frequency	f	100 (Note 1)	Hz
5	Fan-out	-	10	-
6	Rise Time	t_r	50 max.	ns
7	Fall Time	t_f	50 max.	ns
8	Duty Cycle	-	20 min.	%

NOTES

1. Tolerance $\pm 10\%$.



FIGURE 5 - ELECTRICAL CIRCUIT FOR POWER BURN-IN AND OPERATING LIFE TEST



NOTES

- 1. $R = 1.2k\Omega$.



4.8 ENVIRONMENTAL AND ENDURANCE TESTS (CHARTS IV AND V OF ESA/SCC GENERIC SPECIFICATION NO. 9000)

4.8.1 Electrical Measurements on Completion of Environmental Tests

The parameters to be measured on completion of environmental tests are scheduled in Table 6. Unless otherwise stated, the measurements shall be performed at $T_{amb} = +22 \pm 3$ °C.

4.8.2 Electrical Measurements at Intermediate Points during Endurance Tests

The parameters to be measured at intermediate points during endurance tests are as scheduled in Table 6 of this specification.

4.8.3 Electrical Measurements on Completion of Endurance Tests

The parameters to be measured on completion of endurance testing are as scheduled in Table 6 of this specification. Unless otherwise stated, the measurements shall be performed at $T_{amb} = +22 \pm 3$ °C.

4.8.4 Conditions for Operating Life Tests

The requirements for operating life testing are specified in Section 9 of ESA/SCC Generic Specification No. 9000. The conditions for operating life testing shall be as specified in Table 5 of this specification.

4.8.5 Electrical Circuits for Operating Life Tests

Circuits for use in performing the operating life tests are shown in Figure 5.

4.8.6 Conditions for High Temperature Storage Test

The requirements for the high temperature storage test are specified in ESA/SCC Generic Specification No. 9000. The conditions for high temperature storage shall be $T_{amb} = +150(+0-5)$ °C.

**TABLE 6 - ELECTRICAL MEASUREMENTS ON COMPLETION OF ENVIRONMENTAL TESTS AND AT INTERMEDIATE POINTS AND ON COMPLETION OF ENDURANCE TESTS**

No.	CHARACTERISTICS	SYMBOL	SPEC. AND/OR TEST METHOD	TEST CONDITIONS	CHANGE LIMITS		UNIT
					(Δ)	ABSOLUTE	
2	Input Current High Level 1	I_{IH1}	As per Table 2	As per Table 2	± 1.0	-	μA
8	Input Current High Level 3	I_{IH3}	As per Table 2	As per Table 2	-	100	μA
21 to 25	Input Current Low Level	I_{IL}	As per Table 2	As per Table 2	± 12	-	μA
26	Output Voltage Low Level 1	V_{OL1}	As per Table 2	As per Table 2	± 60	-	mV
27 to 42	Output Voltage Low Level 2	V_{OL2}	As per Table 2	As per Table 2	± 60	-	mV
43	Output Voltage High Level 1	V_{OH1}	As per Table 2	As per Table 2	± 240	-	mV
44 to 59	Output Voltage High Level 2	V_{OH2}	As per Table 2	As per Table 2	± 240	-	mV
77	Supply Current	I_{CC}	As per Table 2	As per Table 2	± 20	-	%

 	<p>ESA/SCC Detail Specification No. 9306/035</p>	<p>PAGE 31 ISSUE 2</p>
---	--	----------------------------

APPENDIX 'A'

Page 1 of 1

AGREED DEVIATIONS FOR TEXAS INSTRUMENTS (F)

ITEMS AFFECTED	DESCRIPTION OF DEVIATIONS
Para. 4.2.1	Scanning Electron Microscope (SEM) Inspection may be performed using TIF document TIF 3.61.610.001.
Para. 4.2.2	Prior to Die Shear Test TIF may perform a Radiographic Inspection on the randomly chosen samples to be subjected to this test, using TIF document TIF 50.42-3002.
Para. 4.2.3	Radiographic Inspection may be performed using TIF document TIF 50.42-3002.