



europaean space agency
agence spatiale européenne

Pages 1 to 43

**INTEGRATED CIRCUITS, SILICON MONOLITHIC,
CMOS SILICON GATE, STATIC, 16K (2048 x 8 BIT)
ASYNCHRONOUS RANDOM ACCESS MEMORY
WITH 3-STATE OUTPUTS,
BASED ON TYPES HM65162 AND HM65162B
ESA/SCC Detail Specification No. 9301/015**



**space components
coordination group**

| Issue/Rev. | Date | Approved by | |
|--------------|------------|---------------|---------------------------------------|
| | | SCCG Chairman | ESA Director General or his Deputy |
| Issue 1 | March 1992 | | |
| Revision 'A' | July 1993 | | |
| | | | |
| | | | |

**SCC**ESA/SCC Detail Specification
No. 9301/015

Rev. 'A'

PAGE 2

ISSUE 1

DOCUMENTATION CHANGE NOTICE

| Rev. Letter | Rev. Date | Reference | CHANGE Item | Approved DCR No. |
|-------------|--|-----------|--|------------------|
| 'A' | July '93 | P1 | Cover Page | None |
| | | P2 | DCN | None |
| | | P18 | Table 2 : Nos. 17 to 30, Nos. 31 to 38 and Nos. 39 to 52, minimum limit amended | 23576 |
| | | P19 | Table 2 : Nos. 53 to 60, minimum limit amended | 23576 |
| | | P26 | Table 3 : Nos. 17 to 30, Nos. 31 to 38 and Nos. 39 to 52, minimum limit amended | 23576 |
| | | P27 | Table 3 : Nos. 53 to 60, minimum limit amended | 23576 |
| | | P36 | Table 6 : Nos. 17 to 30, Nos. 31 to 38, Nos. 39 to 52 and Nos. 53 to 60, minimum limit amended | 23576 |
| P39 | Table 7 : Nos. 17 to 30, Nos. 31 to 38, Nos. 39 to 52 and Nos. 53 to 60, minimum limit amended | 23576 | | |

**TABLE OF CONTENTS**

| | <u>Page</u> |
|---|-------------|
| 1. <u>GENERAL</u> | 5 |
| 1.1 Scope | 5 |
| 1.2 Component Type Variants | 5 |
| 1.3 Maximum Ratings | 5 |
| 1.4 Parameter Derating Information | 5 |
| 1.5 Physical Dimensions | 5 |
| 1.6 Pin Assignment | 5 |
| 1.7 Truth Table | 5 |
| 1.8 Circuit Schematic | 5 |
| 1.9 Functional Diagram | 5 |
| 1.10 Handling Precautions | 5 |
| 1.11 Input Protection Network | 5 |
| 2. <u>APPLICABLE DOCUMENTS</u> | 14 |
| 3. <u>TERMS, DEFINITIONS, ABBREVIATIONS, SYMBOLS AND UNITS</u> | 14 |
| 4. <u>REQUIREMENTS</u> | 14 |
| 4.1 General | 14 |
| 4.2 Deviations from Generic Specification | 15 |
| 4.2.1 Deviations from Special In-process Controls | 15 |
| 4.2.2 Deviations from Final Production Tests | 15 |
| 4.2.3 Deviations from Burn-in Tests | 15 |
| 4.2.4 Deviations from Qualification Tests | 15 |
| 4.2.5 Deviations from Lot Acceptance Tests | 15 |
| 4.3 Mechanical Requirements | 15 |
| 4.3.1 Dimension Check | 15 |
| 4.3.2 Weight | 15 |
| 4.4 Materials and Finishes | 15 |
| 4.4.1 Case | 15 |
| 4.4.2 Lead Material and Finish | 15 |
| 4.5 Marking | 16 |
| 4.5.1 General | 16 |
| 4.5.2 Lead Identification | 16 |
| 4.5.3 The SCC Component Number | 16 |
| 4.5.4 Traceability Information | 16 |
| 4.6 Electrical Measurements | 16 |
| 4.6.1 Electrical Measurements at Room Temperature | 16 |
| 4.6.2 Electrical Measurements at High and Low Temperatures | 16 |
| 4.6.3 Circuits for Electrical Measurements | 16 |
| 4.7 Burn-in Tests | 17 |
| 4.7.1 Parameter Drift Values | 17 |
| 4.7.2 Conditions for Power Burn-in | 17 |
| 4.7.3 Electrical Circuits for Power Burn-in | 17 |
| 4.8 Environmental and Endurance Tests | 35 |
| 4.8.1 Electrical Measurements on Completion of Environmental Tests | 35 |
| 4.8.2 Electrical Measurements at Intermediate Points during Endurance Tests | 35 |
| 4.8.3 Electrical Measurements on Completion of Endurance Tests | 35 |
| 4.8.4 Conditions for Operating Life Tests | 35 |
| 4.8.5 Electrical Circuits for Operating Life Tests | 35 |
| 4.8.6 Conditions for High Temperature Storage Test | 35 |



| | <u>Page</u> |
|------------------------------------|-------------|
| 4.9 Total Dose Irradiation Testing | 35 |
| 4.9.1 Application | 35 |
| 4.9.2 Bias Conditions | 35 |
| 4.9.3 Electrical Measurements | 35 |

TABLES

| | |
|--|----|
| 1(a) Type Variants | 6 |
| 1(b) Maximum Ratings | 6 |
| 2 Electrical Measurements at Room Temperature - d.c. Parameters | 18 |
| Electrical Measurements at Room Temperature - a.c. Parameters | 21 |
| 3 Electrical Measurements at High and Low Temperatures | 26 |
| 4 Parameter Drift Values | 32 |
| 5 Conditions for Power Burn-in and Operating Life Test | 33 |
| 6 Electrical Measurements at Intermediate Points and on Completion of Endurance Testing | 36 |
| 7 Electrical Measurements During and on Completion of Irradiation Testing | 39 |

FIGURES

| | |
|--|-----|
| 1 Not applicable | N/A |
| 2 Physical Dimensions | 7 |
| 3(a) Pin Assignment | 10 |
| 3(b) Truth Table | 11 |
| 3(c) Circuit Schematic | 13 |
| 3(d) Functional Diagram | 13 |
| 3(e) Input Protection Network | 13 |
| 4 Circuits for Electrical Measurements | 29 |
| 5 Electrical Circuit for Power Burn-in and Operating Life Test | 34 |
| 6 Bias Conditions for Irradiation Testing | 38 |

APPENDICES (Applicable to specific Manufacturers only)

| | |
|--|----|
| 'A' AGREED DEVIATIONS FOR MATRA-HARRIS (F) | 40 |
|--|----|

**1. GENERAL****1.1 SCOPE**

This specification details the ratings, physical and electrical characteristics, test and inspection data for a silicon, monolithic, CMOS Silicon Gate, Static, 16K (2048 x 8 BIT) Asynchronous Random Access Memory with 3-State Outputs, based on Types HM65162 and HM65162B. It shall be read in conjunction with ESA/SCC Generic Specification No. 9000, the requirements of which are supplemented herein.

1.2 COMPONENT TYPE VARIANTS

Variants of the basic type integrated circuits specified herein, which are also covered by this specification, are given in Table 1(a).

1.3 MAXIMUM RATINGS

The maximum ratings, which shall not be exceeded at any time during use or storage, applicable to the integrated circuits specified herein, are as scheduled in Table 1(b).

1.4 PARAMETER DERATING INFORMATION (FIGURE 1)

Not applicable.

1.5 PHYSICAL DIMENSIONS

As per Figure 2.

1.6 PIN ASSIGNMENT

As per Figure 3(a).

1.7 TRUTH TABLE

As per Figure 3(b).

1.8 CIRCUIT SCHEMATIC

As per Figure 3(c).

1.9 FUNCTIONAL DIAGRAM

As per Figure 3(d).

1.10 HANDLING PRECAUTIONS

These devices are susceptible to damage by electrostatic discharge. Therefore, suitable precautions shall be employed for protection during all phases of manufacture, testing, packaging, shipment and any handling.

These components are categorised as Class 1 with a Minimum Critical Path Failure Voltage of 500 Volts.

1.11 INPUT PROTECTION NETWORK

Double diode protection shall be incorporated into each input as shown in Figure 3(e).



TABLE 1(a) - TYPE VARIANTS

| VARIANT | BASED ON TYPE | CASE | FIGURE | LEAD MATERIAL AND/OR FINISH |
|---------|---------------|------|--------|-----------------------------|
| 01 | HM65162 | DIL | 2(a) | D2 |
| 02 | HM65162 | CCP | 2(b) | 2 |
| 03 | HM65162B | DIL | 2(a) | D2 |
| 04 | HM65162B | CCP | 2(b) | 2 |

TABLE 1(b) - MAXIMUM RATINGS

| NO. | CHARACTERISTICS | SYMBOL | MAXIMUM RATINGS | UNITS | REMARKS |
|-----|--|---------------|------------------------|-------|--------------------|
| 1 | Supply Voltage | V_{DD} | -0.3 to +7.0 | V | Note 1 |
| 2 | Input Voltage | V_{IN} | -0.3 to $V_{DD} + 0.3$ | V | Note 2 Power On |
| 3 | D.C. Input Current | $\pm I_{IN}$ | 1.0 | mA | |
| 4 | Output Current | $\pm I_{OUT}$ | 100 | mA | Note 3 |
| 5 | Device Dissipation (Continuous) | P_D | 820 | mW | Per Package |
| 6 | Operating Temperature Range | T_{op} | -55 to +125 | °C | T_{amb} |
| 7 | Storage Temperature Range | T_{stg} | -65 to +165 | °C | |
| 8 | Soldering Temperature For DIP For CCP | T_{sol} | +300 +245 | °C | Note 4 Note 5 |
| 9 | Thermal Resistance Variants 01 and 03 Variants 02 and 04 | $R_{TH(J-A)}$ | 44 48 | °C/W | |
| 10 | Junction Temperature | T_J | 150 | °C | |

NOTES

1. Device is functional from +4.5V to +5.5V with reference to Ground.
2. $V_{DD} + 0.3V$ should not exceed +7.0V.
3. The maximum output current of any single output.
4. Duration 10 seconds maximum at a distance of not less than 1.5mm from the device body and the same lead shall not be resoldered until 3 minutes have elapsed.
5. Duration 5 seconds maximum and the same terminal shall not be resoldered until 3 minutes have elapsed.

FIGURE 1 - PARAMETER DERATING INFORMATION

Not applicable



FIGURE 2 - PHYSICAL DIMENSIONS

FIGURE 2(a) - DUAL-IN-LINE PACKAGE, 24 PIN

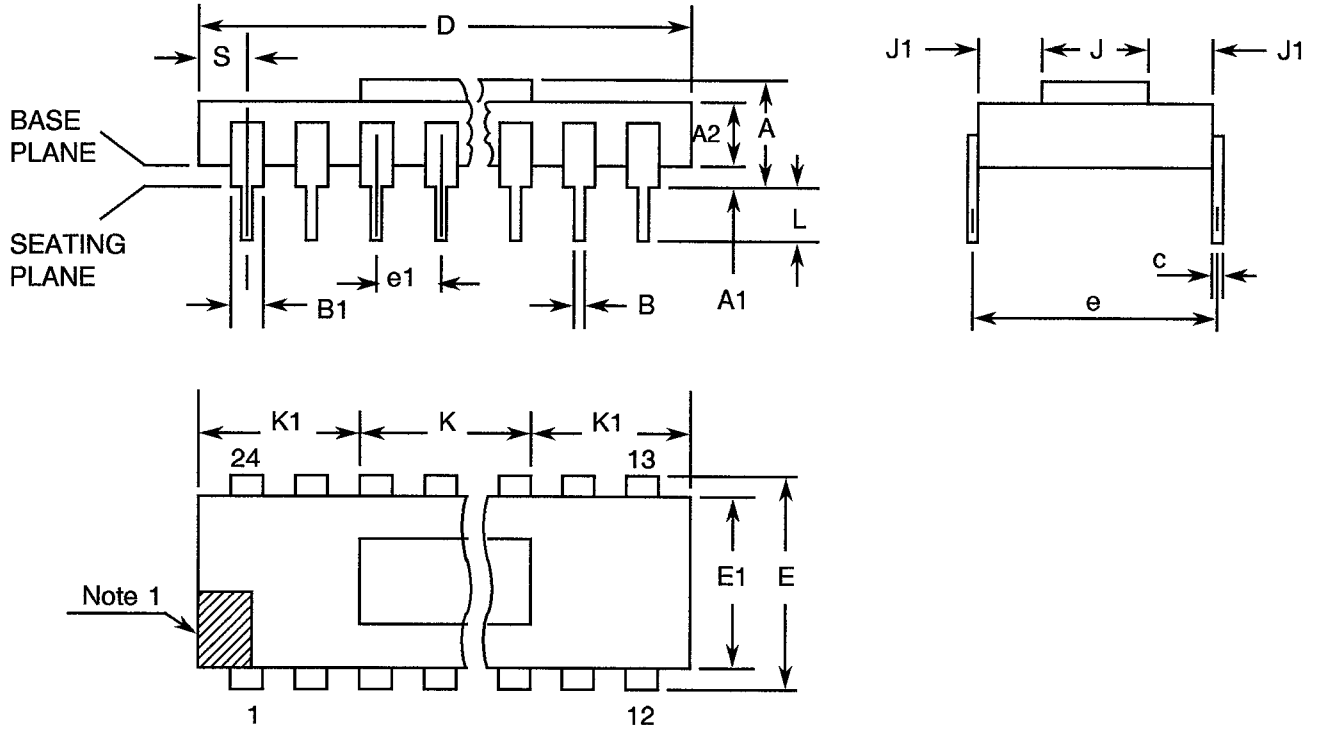

| SYMBOL | MILLIMETERS | | NOTES |
|--------|---------------|-------|-------|
| | MIN. | MAX. | |
| A | 2.20 | 4.80 | |
| A1 | 0.51 | 1.77 | 3 |
| A2 | 1.83 | 2.28 | 3 |
| B | 0.38 | 0.58 | 8 |
| B1 | 0.97 | 1.52 | 8 |
| c | 0.20 | 0.30 | 8 |
| D | 29.88 | 30.98 | |
| E | 15.12 | 15.87 | 4 |
| E1 | 14.51 | 15.49 | |
| e | 15.24 TYPICAL | | |
| e1 | 2.54 TYPICAL | | 6,9 |
| J | 10.29 TYPICAL | | |
| J1 | 2.40 TYPICAL | | |
| K | 10.29 TYPICAL | | |
| K1 | 10.29 TYPICAL | | |
| L | 3.18 | 4.44 | 8 |
| S | 0.77 | 1.65 | 7 |

NOTES: See Page 9.



FIGURE 2 - PHYSICAL DIMENSIONS (CONTINUED)

FIGURE 2(b) - CHIP CARRIER, 32-TERMINAL

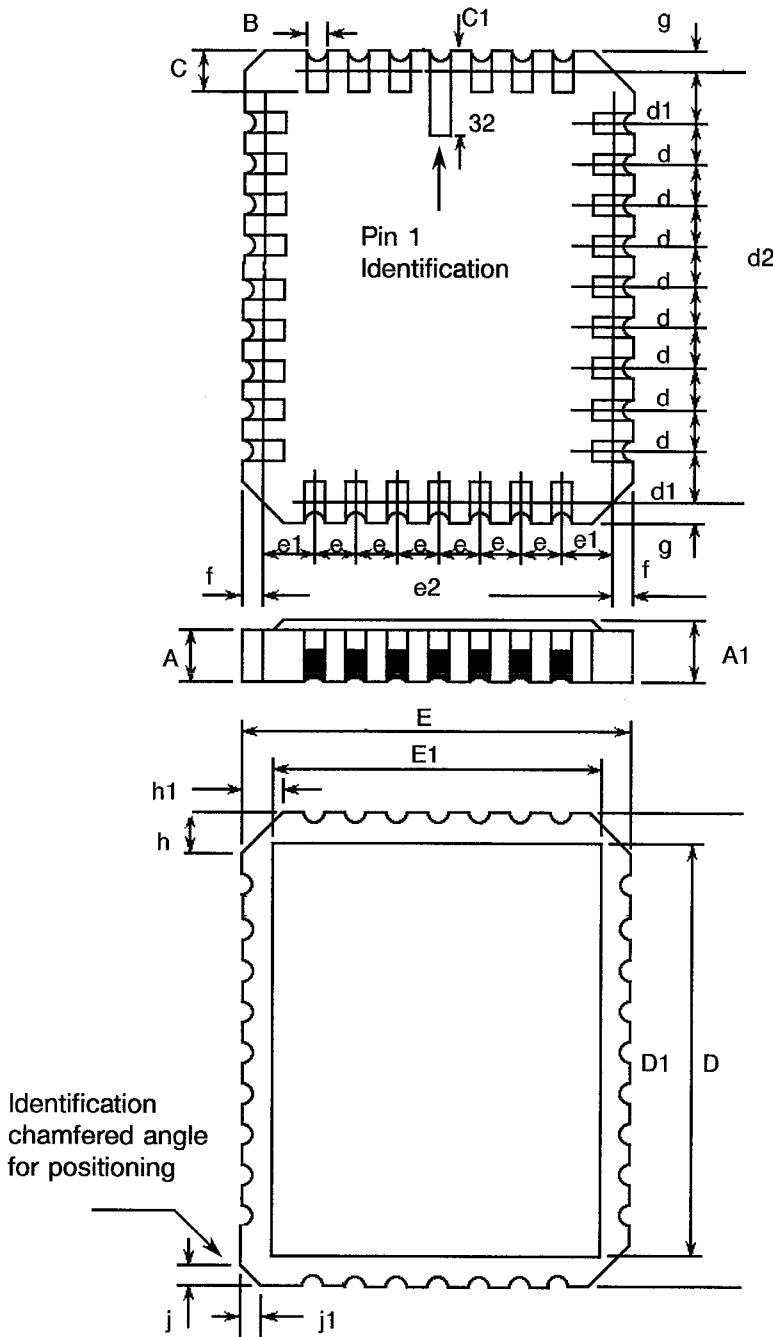

| SYMBOL | MILLIMETRES | | NOTES |
|--------|---------------|-------|-------|
| | MIN | MAX | |
| A | 1.62 | 1.88 | |
| A1 | 1.88 | 2.18 | |
| B | 0.635 TYPICAL | | 8 |
| C | 1.14 | 1.40 | 8 |
| C1 | 1.95 | 2.36 | |
| D | 13.81 | 14.22 | |
| D1 | 12.95 TYPICAL | | |
| d, d1 | 1.27 TYPICAL | | 5, 9 |
| d2 | 12.70 TYPICAL | | |
| E | 11.30 | 11.63 | |
| E1 | 10.41 TYPICAL | | |
| e, e1 | 1.27 TYPICAL | | 5, 9 |
| e2 | 10.16 TYPICAL | | |
| f, g | - | 0.76 | |
| h, h1 | 1.02 TYPICAL | | 10 |
| j, j1 | 0.51 TYPICAL | | 11 |

**SCC**

ESA/SCC Detail Specification

No. 9301/015

PAGE 9

ISSUE 1

FIGURE 2 - PHYSICAL DIMENSIONS (CONTINUED)**NOTES TO FIGURES 2(a) TO 2(b) INCLUSIVE**

1. Index area: a notch, letter or dot shall be located adjacent to Pin 1 and shall be within the shaded area shown. For chip carrier packages the index shall be as defined in Figure 2(b).
2. Not applicable.
3. The dimension shall be measured from the seating plane to the base plane.
4. The dimension allows for off-centre lids, meniscus and glass overrun.
5. The true position pin or terminal spacing is 1.27mm between centrelines. Each pin or terminal centreline shall be located within 0.13mm of its true longitudinal position relative to Pin 1 and the highest pin number.
6. The true position pin spacing is 2.54mm between centrelines. Each pin centreline shall be located within 0.25mm of its true longitudinal position relative to Pin 1 and the highest pin number.
7. Applies to all 4 corners.
8. All leads or terminals.
9. 22 spaces for dual-in-line packages.
28 spaces for chip carrier packages.
10. 3 non-index corners - 6 dimensions.
11. Index corner only - 2 dimensions.



FIGURE 3(b) - TRUTH TABLE

| \overline{CS} | \overline{OE} | \overline{W} | DATA I/O | MODE |
|-----------------|-----------------|----------------|------------------|----------------|
| H | X | X | Z | Standby |
| L | X | L | D _{IN} | Write |
| L | L | H | D _{OUT} | Read |
| L | H | H | Z | Output Disable |

NOTES 1. Logic Level Definitions, L = Low Level, H = High Level, Z = High Impedance, X = Irrelevant.

TIMING WAVEFORMS

READ CYCLE

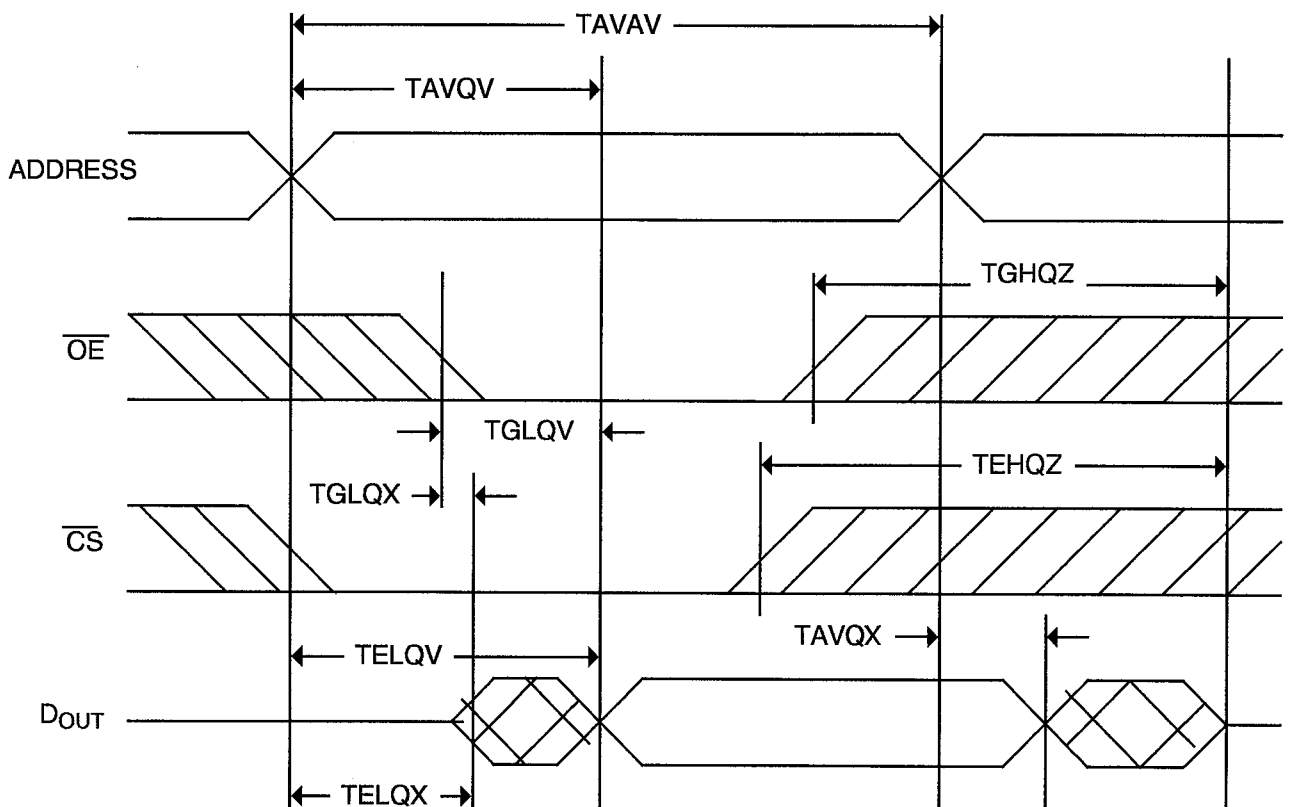

NOTES

1. \overline{W} is High throughout Read Cycle.

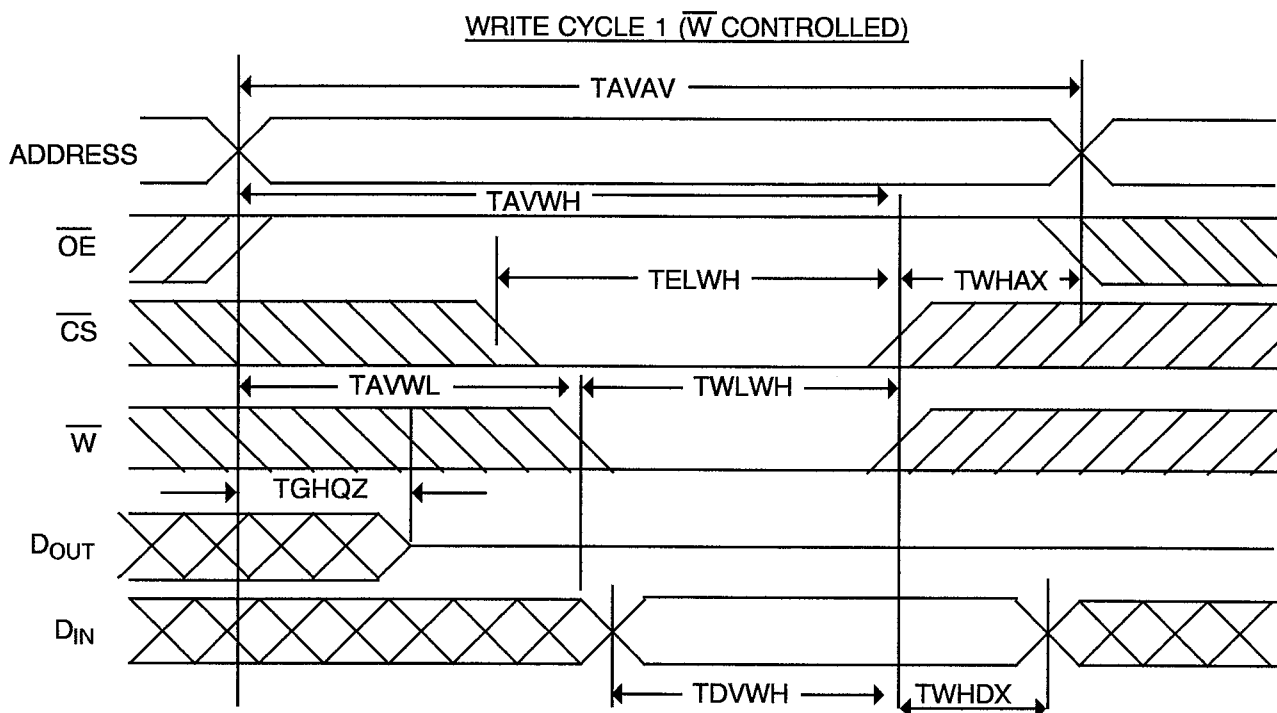

NOTES

1. The internal write time of the memory is defined by the overlap of \overline{CS} Low and \overline{W} Low. Both signals must be Low to initiate a write and either signal can terminate a write by going High. The data input setup and hold timing should be referenced to the rising edge of the signal that terminates the write.
2. \overline{OE} is Low throughout Write Cycle.

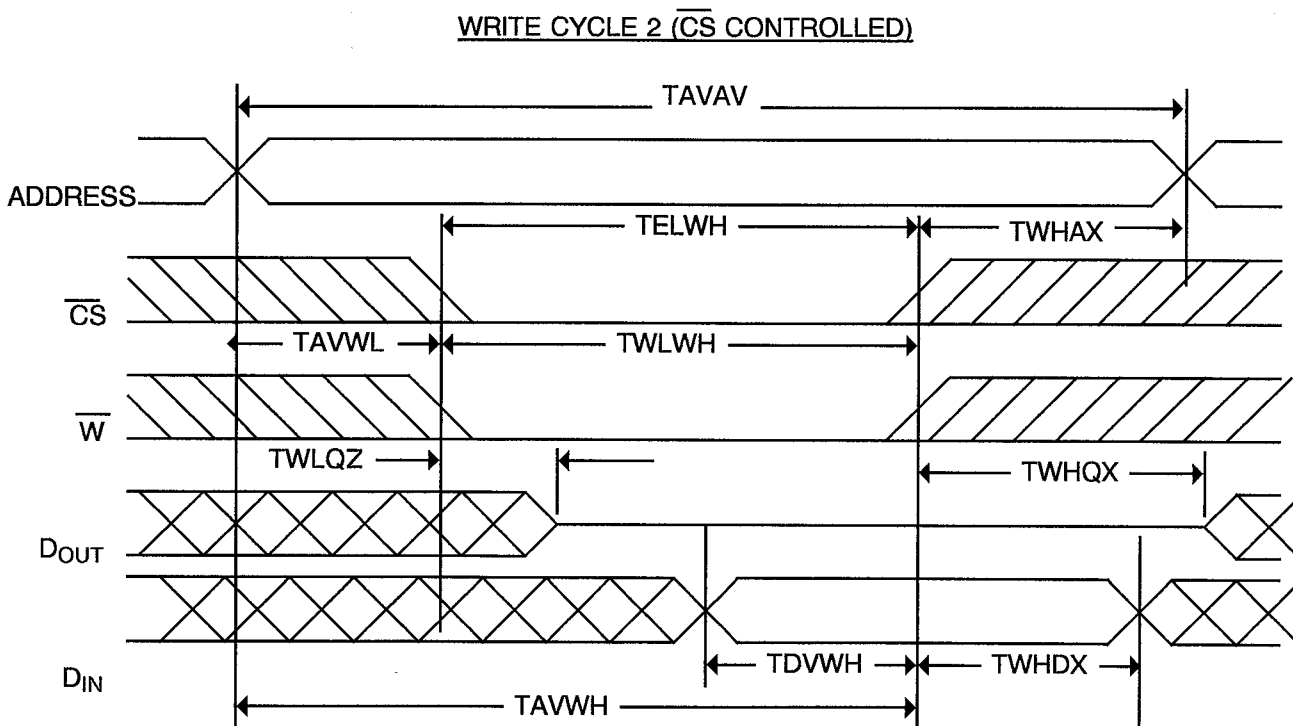

NOTES

1. The internal write time of the memory is defined by the overlap of \overline{CS} Low and \overline{W} Low. Both signals must be Low to initiate a write and either signal can terminate a write by going High. The data input setup and hold timing should be referenced to the rising edge of the signal that terminates the write.
2. \overline{OE} is Low throughout Write Cycle.



FIGURE 3(c) - CIRCUIT SCHEMATIC

Not applicable

FIGURE 3(d) - FUNCTIONAL DIAGRAM

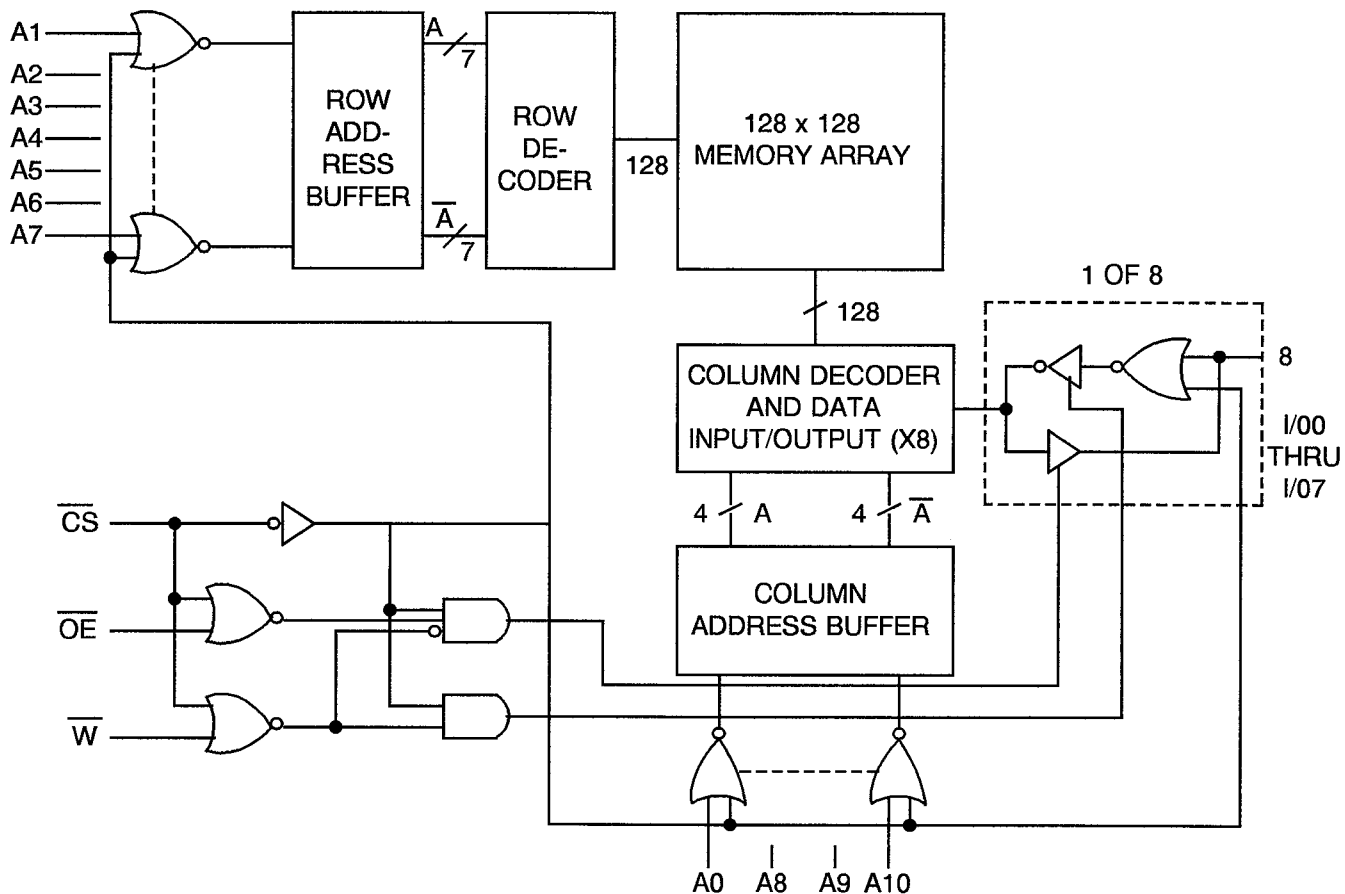
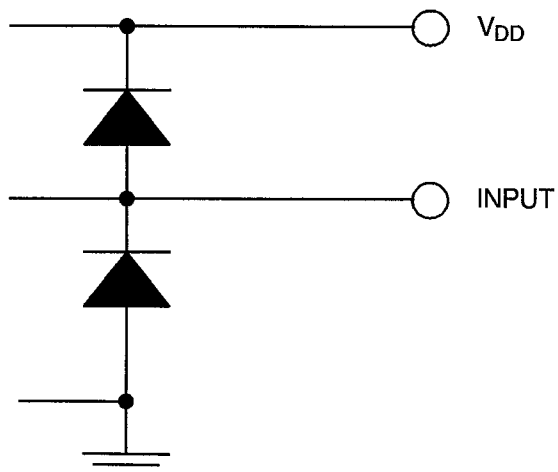

FIGURE 3(e) - INPUT PROTECTION NETWORK



**2. APPLICABLE DOCUMENTS**

The following documents form part of this specification and shall be read in conjunction with it:-

- (a) ESA/SCC Generic Specification No. 9000 for Integrated Circuits.
- (b) MIL-STD-883, Test Methods and Procedures for Micro-electronics.

3. TERMS, DEFINITIONS, ABBREVIATIONS, SYMBOLS AND UNITS

For the purpose of this specification, the terms, definitions, abbreviations, symbols and units specified in ESA/SCC Basic Specification No. 21300 shall apply. In addition, the following abbreviations are used:

- V_{IC} = Input Clamp Voltage.
- I_{OZ} = Output Leakage Current Third State
- C_{IN} = Input Capacitance.
- $C_{I/O}$ = Capacitance Input/Output.
- TAVAV = Cycle Time.
- TAVQV = Address Access Time
- TELQV = \overline{CS} Access Time.
- TELQX = \overline{CS} Low Output Enable Time.
- TGLQV = Output Enable Access Time.
- TGLQX = \overline{OE} Low Output Enable Time.
- TEHQZ = \overline{CS} High Output Disable Time.
- TGHQZ = \overline{OE} High Output Disable Time.
- TAVQX = Output Change from Address Change.
- TELWH = \overline{CS} Low to End of Write.
- TAVWL = Address Set-up Time.
- TWLWH = \overline{W} Low Pulse Width.
- TWHAX = Address Hold from Write End.
- TWLQZ = \overline{W} Low Output Disable Time.
- TDVWH = Data Set-up Time.
- TWHDX = Data Hold Time.
- TWHQX = \overline{W} High Output Enable Time
- TAVWH = Address Valid to Write End.
- t_r = Recovery Time from Data Retention.

4. REQUIREMENTS**4.1 GENERAL**

The complete requirements for procurement of the integrated circuits specified herein are stated in this specification and ESA/SCC Generic Specification No. 9000 for Integrated Circuits. Deviations from the Generic Specification, applicable to this specification only, are listed in Para. 4.2.

Deviations from the applicable Generic Specification and this Detail Specification, formally agreed with specific Manufacturers on the basis that the alternative requirements are equivalent to the ESA/SCC requirements and do not affect the components' reliability, are listed in the appendices attached to this specification.



4.2 DEVIATIONS FROM GENERIC SPECIFICATION

4.2.1 Deviations from Special In-process Controls

- (a) Para. 5.2.2, Total Dose Irradiation Testing: Shall be performed during irradiation qualification and maintenance of qualification.
- (b) Para. 5.2.2, Total Dose Irradiation Testing: Shall be performed during procurement on an irradiation lot acceptance basis at the total dose irradiation level specified in the Purchase Order.

4.2.2 Deviations from Final Production Tests (Chart II)

None.

4.2.3 Deviations from Burn-in Tests (Chart III)

- (a) Para. 7.1.1(a), "High Temperature Reverse Bias" tests and subsequent electrical measurements related to this test shall be omitted.

4.2.4 Deviations from Qualification Tests (Chart IV)

- (a) The electrical measurements specified at the end of Subgroup I and II tests shall be carried out as stated in Table 2 of this specification.

4.2.5 Deviations from Lot Acceptance Tests (Chart V)

- (a) The electrical measurements referenced 9.9.4 shall be performed as stated in Table 2 of this specification.

4.3 MECHANICAL REQUIREMENTS

4.3.1 Dimension Check

The dimensions of the integrated circuits specified herein shall be checked. They shall conform to those shown in Figure 2.

4.3.2 Weight

The maximum weight of the integrated circuits specified herein shall be 5.0 grammes for the dual-in-line package and 2.0 grammes for the chip carrier package.

4.4 MATERIALS AND FINISHES

The materials shall be as specified herein. Where a definite material is not specified, a material which will enable the integrated circuits specified herein to meet the performance requirements of this specification shall be used. Acceptance or approval of any constituent material does not guarantee acceptance of the finished product.

4.4.1 Case

The case shall be hermetically sealed and have a ceramic body and the lids shall be brazed or preform-soldered.

4.4.2 Lead Material and Finish

For dual-in-line packages, the material shall be Type 'D' with Type '2' finish in accordance with the requirements of ESA/SCC Basic Specification No. 23500. For chip carrier packages the finish shall be Type '2' in accordance with the requirements of ESA/SCC Basic Specification No. 23500. (See Table 1(a) for Type Variants).



4.5 MARKING

4.5.1 General

The marking of all components delivered to this specification shall be in accordance with the requirements of ESA/SCC Basic Specification No. 21700. Each component shall be marked in respect of:-

- (a) Lead Identification.
- (b) The SCC Component Number.
- (c) Traceability Information.

4.5.2 Lead Identification

For dual-in-line packages, an index shall be located at the top of the package in the position defined in Note 1 to Figure 2 or, alternatively, a tab may be used to identify Pin No. 1. The pin numbering must be read with the index or tab on the left-hand side. For chip carrier packages, the index shall be as defined by Figure 2(b).

4.5.3 The SCC Component Number

Each component shall bear the SCC Component Number which shall be constituted and marked as follows:

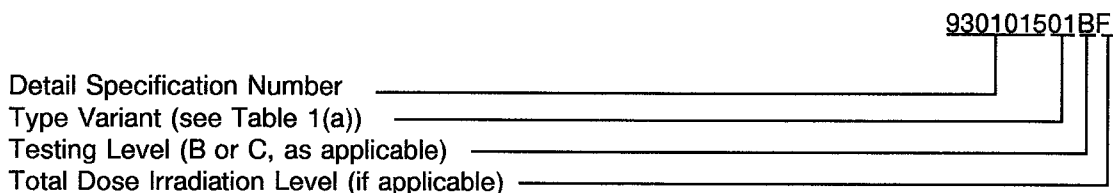

The Total Dose Irradiation Level designation shall be added for those devices for which a sample has been successfully tested to the level in question. For these devices, a code letter shall be added in accordance with the requirements of ESA/SCC Basic Specification No. 22900.

4.5.4 Traceability Information

Each component shall be marked in respect of traceability information in accordance with the requirements of ESA/SCC Basic Specification No. 21700.

4.6 ELECTRICAL MEASUREMENTS

4.6.1 Electrical Measurements at Room Temperature

The parameters to be measured in respect of electrical characteristics are scheduled in Table 2. Unless otherwise specified, the measurements shall be performed at $T_{amb} = +22 \pm 3$ °C.

4.6.2 Electrical Measurements at High and Low Temperatures

The parameters to be measured at high and low temperatures are scheduled in Table 3. The measurements shall be performed at $T_{amb} = +125(+0-5)$ °C and $-55(+5-0)$ °C respectively.

4.6.3 Circuits for Electrical Measurements

Circuits and test sequences for use in performing electrical measurements listed in Tables 2 and 3 of this specification are shown in Figure 4.



4.7 BURN-IN TESTS

4.7.1 Parameter Drift Values

The parameter drift values applicable to Power Burn-in are specified in Table 4 of this specification. Unless otherwise stated, measurements shall be performed at $T_{amb} = +22 \pm 3$ °C. The parameter drift values (Δ), applicable to the parameters scheduled, shall not be exceeded. In addition to these drift value requirements, the appropriate limit value specified for a given parameter in Table 2 shall not be exceeded.

4.7.2 Conditions for Power Burn-in

The requirements for Power Burn-in are specified in Section 7 of ESA/SCC Generic Specification No. 9000. The conditions for Power Burn-in shall be as specified in Table 5 of this specification.

4.7.3 Electrical Circuits for Power Burn-in

Circuits for use in performing the Power Burn-in tests are shown in Figure 5 of this specification.

**TABLE 2 - ELECTRICAL MEASUREMENTS AT ROOM TEMPERATURE - d.c. PARAMETERS**

| NO. | CHARACTERISTICS | SYMBOL | TEST METHOD MIL-STD 883 | TEST FIG. | TEST CONDITIONS (PINS UNDER TEST D = DIP, C = CCP) | LIMITS | | UNIT |
|----------|--|-----------|-------------------------|-----------|---|--------|------|---------|
| | | | | | | MIN | MAX | |
| 1 to 6 | Functional Test 1 (Nominal Inputs) | - | 3014 | 3(b) | Verify Truth Table. For Input Conditions and Test Patterns, see Note 1 | - | - | - |
| 7 | Functional Test 2 (Worst Case Inputs) | - | 3014 | 3(b) | Verify Truth Table. For Input Conditions and Test Patterns, see Note 1 | - | - | - |
| 8 to 16 | Functional Test 3 (Worst Case Outputs) | - | 3014 | 3(b) | Verify Truth Table. For Input Conditions and Test Patterns, see Note 1 | - | - | - |
| 17 to 30 | Input Current Low Level 1 | I_{IL1} | 3009 | 4(a) | V_{IN} (Under Test) = 0V V_{IN} (Remaining Inputs) = 5.5V $V_{DD} = 5.5V, V_{SS} = 0V$ (Pins D 1-2-3-4-5-6-7-8-18-19-20-21-22-23) (Pins C 4-5-6-7-8-9-10-11-23-24-25-26-28-29) | -1.0 | +1.0 | μA |
| 31 to 38 | Input Current Low Level 2 | I_{IL2} | 3009 | 4(a) | V_{IN} (Under Test) = 0V $V_{IN(\overline{CS})} = 0V$ V_{IN} (Remaining Inputs) = 5.5V $V_{DD} = 5.5V, V_{SS} = 0V$ Note 2 (Pins D 9-10-11-13-14-15-16-17) (Pins C 13-14-15-18-19-20-21-22) | -1.0 | +1.0 | μA |
| 39 to 52 | Input Current High Level 1 | I_{IH1} | 3010 | 4(b) | V_{IN} (Under Test) = 5.5V V_{IN} (Remaining Inputs) = 0V $V_{DD} = 5.5V, V_{SS} = 0V$ (Pins D 1-2-3-4-5-6-7-8-18-19-20-21-22-23) (Pins C 4-5-6-7-8-9-10-11-23-24-25-26-28-29) | -1.0 | +1.0 | μA |

NOTES: See Page 24.

**SEC**ESA/SCC Detail Specification
No. 9301/015

Rev. 'A'

PAGE 19

ISSUE 1

TABLE 2 - ELECTRICAL MEASUREMENTS AT ROOM TEMPERATURE - d.c. PARAMETERS (CONTINUED)

| NO. | CHARACTERISTICS | SYMBOL | TEST METHOD MIL-STD 883 | TEST FIG. | TEST CONDITIONS (PINS UNDER TEST D = DIP, C = CCP) | LIMITS | | UNIT |
|-----------|------------------------------------|-----------|-------------------------|-----------|--|--------|-------|---------|
| | | | | | | MIN | MAX | |
| 53 to 60 | Input Current High Level 2 | I_{IH2} | 3010 | 4(b) | V_{IN} (Under Test) = 5.5V $V_{IN(\overline{OE})}$ = 5.5V V_{IN} (Remaining Inputs) = 0V V_{DD} = 5.5V, V_{SS} = 0V Note 2 (Pins D 9-10-11-13-14-15-16-17) (Pins C 13-14-15-18-19-20-21-22) | - 1.0 | + 1.0 | μ A |
| 61 to 68 | Output Voltage Low Level | V_{OL} | 3007 | 4(c) | V_{IL} = 0V, V_{IH} = 3.0V I_{OL} = 4.0mA, $V_{IN(\overline{W})}$ = 4.5V $V_{IN(\overline{CS})}$ = 0V, $V_{IN(\overline{OE})}$ = 0V V_{DD} = 4.5V, V_{SS} = 0V Note 3 (Pins D 9-10-11-13-14-15-16-17) (Pins C 13-14-15-18-19-20-21-22) | - | 0.4 | V |
| 69 to 76 | Output Voltage High Level | V_{OH} | 3006 | 4(d) | V_{IL} = 0V, V_{IH} = 3.0V I_{OH} = - 1.0mA, $V_{IN(\overline{W})}$ = 4.5V $V_{IN(\overline{CS})}$ = 0V, $V_{IN(\overline{OE})}$ = 0V V_{DD} = 4.5V, V_{SS} = 0V Note 4 (Pins D 9-10-11-13-14-15-16-17) (Pins C 13-14-15-18-19-20-21-22) | 2.4 | - | V |
| 77 to 98 | Input Clamp Voltage (to V_{SS}) | V_{IC1} | - | 4(e) | I_{IN} (Under Test) = -100 μ A V_{DD} = Open, V_{SS} = 0V All Other Pins Open (Pins D 1-2-3-4-5-6-7-8-9-10-11-13-14-15-16-17-18-19-20-21-22-23) (Pins C 4-5-6-7-8-9-10-11-13-14-15-18-19-20-21-22-23-24-25-26-28-29) | - 0.2 | - 2.0 | V |
| 99 to 120 | Input Clamp Voltage (to V_{DD}) | V_{IC2} | - | 4(e) | I_{IN} (Under Test) = 100 μ A V_{DD} = 0V, V_{SS} = Open All Other Pins Open (Pins D 1-2-3-4-5-6-7-8-9-10-11-13-14-15-16-17-18-19-20-21-22-23) (Pins C 4-5-6-7-8-9-10-11-13-14-15-18-19-20-21-22-23-24-25-26-28-29) | 0.2 | 2.0 | V |

NOTES: See Page 24.



TABLE 2 - ELECTRICAL MEASUREMENTS AT ROOM TEMPERATURE - d.c. PARAMETERS (CONTINUED)

| NO. | CHARACTERISTICS | SYMBOL | TEST METHOD MIL-STD 883 | TEST FIG. | TEST CONDITIONS (PINS UNDER TEST D = DIP, C = CCP) | LIMITS | | UNIT |
|------------|----------------------------|-------------|-------------------------|-----------|--|--------|------|---------|
| | | | | | | MIN | MAX | |
| 121 | Supply Current (Operating) | I_{DDop} | 3005 | 4(f) | $V_{IN(\overline{OE})} = 0.8V$ V_{IN} (Remaining Inputs) = 0V to 3.0V $f = 2.5MHz$ Pattern: ICCACT $I_{OUT} = 0mA$ $V_{DD} = 5.5V, V_{SS} = 0V$ (Pin D 24) (Pin C 32) | - | 77.5 | mA |
| 122 | Supply Current (Enabled) | I_{DDE} | 3005 | 4(f) | $V_{IN(\overline{CS})} = 0.8V$ V_{IN} (Remaining Inputs) = 0.8V $I_{OUT} = 0mA$ $V_{DD} = 5.5V, V_{SS} = 0V$ (Pin D 24) (Pin C 32) | - | 70 | mA |
| 123 | Supply Current (Standby 1) | I_{DDSB1} | 3005 | 4(f) | $V_{IN(\overline{CS})} = 2.2V$ V_{IN} (Remaining Inputs) = 0.8V $I_{OUT} = 0mA$ $V_{DD} = 5.5V, V_{SS} = 0V$ (Pin D 24) (Pin C 32) | - | 5.0 | mA |
| 124 to 127 | Supply Current (Standby 2) | I_{DDSB2} | 3005 | 4(f) | $V_{IN(\overline{OE})} = V_{DD} - 0.3V$ V_{IN} (Remaining Inputs) = $V_{DD} - 0.3V$ to $-0.3V$ $I_{OUT} = 0mA$ $V_{DD} = 5.5V, V_{SS} = 0V$ Note 5 (Pin D 24) (Pin C 32) | - | 50 | μA |
| 128 | Data Retention Current | I_{DDDR} | 3005 | 4(g) | $V_{IL} = 0V, V_{IH} = 2.0V$ $V_{IN(\overline{CS})} = 2.0V$ $V_{DD} = 2.0V, V_{SS} = 0V$ Note 5 (Pin D 24) (Pin C 32) | - | 20 | μA |
| 129 to 130 | Data Retention | DR | - | - | $V_{IL} = 0V, V_{IH} = 3.0V$ $V_{IN(\overline{CS})} = 4.5V$ $V_{DD} = 4.5V, V_{SS} = 0V$ Note 6 (Pins D 9-10-11-12-13-14-15-16-17) (Pins C 13-14-15-18-19-20-21-22) | - | - | - |

NOTES: See Page 24.



SEC

ESA/SCC Detail Specification
No. 9301/015

PAGE 21

ISSUE 1

TABLE 2 - ELECTRICAL MEASUREMENTS AT ROOM TEMPERATURE - a.c. PARAMETERS

| NO. | CHARACTERISTICS | SYMBOL | TEST METHOD MIL-STD 883 | TEST FIG. | TEST CONDITIONS (PINS UNDER TEST D = DIP, C = CCP) | LIMITS | | UNIT |
|------------|-----------------------------|-----------|-------------------------|-----------|--|----------|----------|------|
| | | | | | | MIN | MAX | |
| 131 to 144 | Input Capacitance | C_{IN} | 3012 | 4(h) | V_{IN} (Not Under Test) = 0V $V_{DD} = V_{SS} = 0V$ Note 7 (Pins D 1-2-3-4-5-6-7-8-18-19-20-21-22-23) (Pins C 4-5-6-7-8-9-10-11-23-24-25-26-28-29) | - | 5.0 | pF |
| 145 to 152 | Input/Output Capacitance | $C_{I/O}$ | 3012 | 4(h) | V_{IN} (Not Under Test) = 0V $V_{DD} = V_{SS} = 0V$ Note 7 (Pins D 9-10-11-13-14-15-16-17) (Pins C 13-14-15-18-19-20-21-22) | - | 7.0 | pF |
| 153 to 158 | Functional Test 4 | - | 3014 | 3(b) | Verify Truth Table. For Input and Output Conditions, see Notes 8 and 9 $V_{DD} = 4.5V$ and 5.5V $V_{SS} = 0V$ | - | - | - |
| 159 to 160 | Access Time (Address) | TAVQV | - | 4(i) | $V_{DD} = 4.5V$ and 5.5V $V_{SS} = 0V$ Notes 8 and 10 Variants 01 and 02 Variants 03 and 04 | - | 85 70 | ns |
| 161 to 162 | Access Time (Chip Select) | TELQV | - | 4(i) | $V_{DD} = 4.5V$ and 5.5V $V_{SS} = 0V$ Notes 8 and 10 Variants 01 and 02 Variants 03 and 04 | - | 85 70 | ns |
| 163 to 164 | Access Time (Output Enable) | TGLQV | - | 4(i) | $V_{DD} = 4.5V$ and 5.5V $V_{SS} = 0V$ Notes 8 and 10 Variants 01 and 02 Variants 03 and 04 | - | 65 50 | ns |
| 165 to 166 | Write Pulse Width (W Low) | TWLWH | - | 4(i) | $V_{DD} = 4.5V$ and 5.5V $V_{SS} = 0V$ Notes 8 and 11 Variants 01 and 02 Variants 03 and 04 | 55 40 | - - | ns |

NOTES: See Page 24.

**TABLE 2 - ELECTRICAL MEASUREMENTS AT ROOM TEMPERATURE - a.c. PARAMETERS (CONTINUED)**

| NO. | CHARACTERISTICS | SYMBOL | TEST METHOD MIL-STD 883 | TEST FIG. | TEST CONDITIONS (PINS UNDER TEST D = DIP, C = CCP) | LIMITS | | UNIT |
|------------------|---|--------|-------------------------------|-----------|---|----------|----------|------|
| | | | | | | MIN | MAX | |
| 167 to 168 | Data Set-up Time | TDVWH | - | 4(i) | V _{DD} = 4.5V and 5.5V V _{SS} = 0V Notes 8 and 11 | 30 | - | ns |
| 169 to 170 | Data Hold Time | TWHDX | - | 4(i) | V _{DD} = 4.5V and 5.5V V _{SS} = 0V Notes 8 and 11 | 10 | - | ns |
| 171 to 172 | Read/Write Cycle Time | TAVAV | - | 4(i) | V _{DD} = 4.5V and 5.5V V _{SS} = 0V Notes 8 and 11 Variants 01 and 02 Variants 03 and 04 | 85 70 | - - | ns |
| 173 to 174 | Output Change from Address Cycle | TAVQX | - | 4(i) | V _{DD} = 4.5V and 5.5V V _{SS} = 0V Notes 8 and 11 | 5.0 | - | ns |
| 175 to 176 | $\overline{\text{CS}}$ Low to End of Write | TELWH | - | 4(i) | V _{DD} = 4.5V and 5.5V V _{SS} = 0V Notes 8 and 11 Variants 01 and 02 Variants 03 and 04 | 55 45 | - - | ns |
| 177 to 178 | Address Set-up Time | TAVWL | - | 4(i) | V _{DD} = 4.5V and 5.5V V _{SS} = 0V Notes 8 and 11 | 0 | - | ns |
| 179 to 180 | Address Valid to End of Write | TAVWH | - | 4(i) | V _{DD} = 4.5V and 5.5V V _{SS} = 0V Notes 8 and 11 Variants 01 and 02 Variants 03 and 04 | 65 50 | - - | ns |
| 181 to 182 | Address Hold from Write End | TWHAX | - | 4(i) | V _{DD} = 4.5V and 5.5V V _{SS} = 0V Notes 8 and 11 | 10 | - | ns |
| 183 to 184 | Output Enable Time ($\overline{\text{CS}}$ Low) | TELQX | - | 4(i) | V _{DD} = 4.5V and 5.5V V _{SS} = 0V Notes 7 and 8 | 5.0 | - | ns |
| 185 to 186 | Output Disable Time (CS High) | TEHQZ | - | 4(i) | V _{DD} = 4.5V and 5.5V V _{SS} = 0V Notes 7 and 8 Variants 01 and 02 Variants 03 and 04 | - - | 50 35 | ns |

NOTES: See Page 24.

**TABLE 2 - ELECTRICAL MEASUREMENTS AT ROOM TEMPERATURE - a.c. PARAMETERS (CONTINUED)**

| NO. | CHARACTERISTICS | SYMBOL | TEST METHOD MIL-STD 883 | TEST FIG. | TEST CONDITIONS (PINS UNDER TEST D = DIP, C = CCP) | LIMITS | | UNIT |
|------------------|----------------------------------|--------|-------------------------------|-----------|--|--------|----------|------|
| | | | | | | MIN | MAX | |
| 187 to 188 | Output Enable Time (OE Low) | TGLQX | - | 4(i) | V _{DD} = 4.5V and 5.5V V _{SS} = 0V Notes 7 and 8 | 5.0 | - | ns |
| 189 to 190 | Output Disable Time (OE High) | TGHQZ | - | 4(i) | V _{DD} = 4.5V and 5.5V V _{SS} = 0V Notes 7 and 8 Variants 01 and 02 Variants 03 and 04 | - - | 40 35 | ns |
| 191 to 192 | Output Disable Time (W Low) | TWLQZ | - | 4(i) | V _{DD} = 4.5V and 5.5V V _{SS} = 0V Notes 7 and 8 Variants 01 and 02 Variants 03 and 04 | - | 50 40 | ns |
| 193 to 194 | Output Enable Time (W High) | TWHQX | - | 4(i) | V _{DD} = 4.5V and 5.5V V _{SS} = 0V Notes 7 and 8 | 0 | - | ns |

NOTES: See Page 24.

**TABLE 2 - ELECTRICAL MEASUREMENTS AT ROOM TEMPERATURE (CONTINUED)****NOTES**

1. Functional test go-no-go with the following test sequences:-

FUNCTIONAL TEST 1

| Pattern | Timing | V _{DD} | V _{SS} | V _{IL} | V _{IH} | I _{OL} | I _{OH} | V _{OUT} (COMP) |
|----------------|--------|-----------------|-----------------|-----------------|-----------------|-----------------|-----------------|-------------------------|
| MARCH, COMARCH | 1.0μS | 4.5V and 5.5V | 0V | 0V | 3.0V | 0.5mA | -0.5mA | 1.5V |
| CHECKERBOARD | 1.0μS | 4.5V and 5.5V | 0V | 0V | 3.0V | 0.5mA | -0.5mA | 1.5V |

FUNCTIONAL TEST 2

| Pattern | Timing | V _{DD} | V _{SS} | V _{IL} | V _{IH} | I _{OL} | I _{OH} | V _{OUT} (COMP) |
|---------|--------|-----------------|-----------------|-----------------|-----------------|-----------------|-----------------|-------------------------|
| MARCH | 1.0μS | 5.0V | 0V | -0.3V | 5.3V | 0.5mA | -0.5mA | 1.5V |

FUNCTIONAL TEST 3

| Pattern | Timing | V _{DD} | V _{SS} | V _{IL} | V _{IH} | I _{OL} | I _{OH} | V _{OUT} (COMP) |
|------------------|--------|-----------------|-----------------|-----------------|-----------------|-----------------|-----------------|-------------------------|
| MARCH | 1.0μS | 7.5V | 0V | 0V | 7.5V | 0.5mA | -0.5mA | 1.5V |
| MARCH | 1.0μS | 4.5V | 0V | 0V | 3.0V | 0.5mA | -0.5mA | 1.5V |
| MARCH | 3.0μS | 4.5V and 5.5V | 0V | 0.8V | 2.2V | 0.5mA | -0.5mA | 1.5V |
| MARCH | 3.0μS | 4.5V and 5.5V | 0V | 0V | 3.0V | 4.0mA | -1.0mA | 1.5V |
| CHIP DESELECT | 1.0μS | 4.5V | 0V | 0V | 3.0V | 0.5mA | -0.5mA | 1.5V |
| GENBL | 1.0μS | 4.5V | 0V | 0V | 3.0V | 0.5mA | -0.5mA | 1.5V |
| LONG CHIP SELECT | 2.5μS | 4.5V | 0V | 0V | 3.0V | 0.5mA | -0.5mA | 1.5V |

2. For I/O ports, the parameters I_{IL2} and I_{IH2} include the third-state output leakage currents (I_{OZL} and I_{OZH}).
3. Select Address Inputs to produce low level output at the pin under test in accordance with Figure 3(b).
4. Select Address Inputs to produce high level output at the pin under test in accordance with Figure 3(b).
5. Measurement is performed with the memory loaded with a background of zeros and then with a background of ones, for all inputs high and then low. Only worst case is recorded.
6. Data Retention Procedure:-
 - (a) Write memory with Checkerboard pattern with Timing = 1μs at the conditions given.
 - (b) Power Down to V_{DD} = 1.6 ± 0V for 250ms. (This is a test condition only. Memory retention cannot be guaranteed if V_{DD} is reduced below 2.0V).
 - (c) Restore to original conditions given, read Memory and compare with original pattern.
 - (d) Repeat the procedure with Checkerboard pattern with Timing = 1μs at the conditions given.
 - (e) For Variants 01 and 02: t_r = 85ns, for Variants 03 and 04: t_r = 70ns.



TABLE 2 - ELECTRICAL MEASUREMENTS AT ROOM TEMPERATURE (CONTINUED)

NOTES

7. Guaranteed but not tested. Characterised at initial design and after major process changes.
8. Test Conditions
Input Pulse Level = 0 to 3.0V
Input t_r and t_f = 5.0ns (max.)
Input/Output Timing Reference Level = 1.5V
Output Load = 1 TTL Gate equivalent + $C_L \leq 100\text{pF}$.
 $f = 2.5\text{MHz}$
9. Tested go-no-go using March, Comarch and Walkcol patterns.
10. Parameters measured using March pattern during Functional Test 4.
11. Parameters tested go-no-go during Functional Test 4.



TABLE 3 - ELECTRICAL MEASUREMENTS AT HIGH AND LOW TEMPERATURES

| NO. | CHARACTERISTICS | SYMBOL | TEST METHOD MIL-STD 883 | TEST FIG. | TEST CONDITIONS (PINS UNDER TEST D = DIP, C = CCP) | LIMITS | | UNIT |
|----------|--|-----------|-------------------------|-----------|---|--------|-------|---------|
| | | | | | | MIN | MAX | |
| 1 to 6 | Functional Test 1 (Nominal Inputs) | - | 3014 | 3(b) | Verify Truth Table. For Input Conditions and Test Patterns, see Note 1 | - | - | - |
| 7 | Functional Test 2 (Worst Case Inputs) | - | 3014 | 3(b) | Verify Truth Table. For Input Conditions and Test Patterns, see Note 1 | - | - | - |
| 8 to 16 | Functional Test 3 (Worst Case Outputs) | - | 3014 | 3(b) | Verify Truth Table. For Input Conditions and Test Patterns, see Note 1 | - | - | - |
| 17 to 30 | Input Current Low Level 1 | I_{IL1} | 3009 | 4(a) | V_{IN} (Under Test) = 0V V_{IN} (Remaining Inputs) = 5.5V V_{DD} = 5.5V, V_{SS} = 0V (Pins D 1-2-3-4-5-6-7-8-18-19-20-21-22-23) (Pins C 4-5-6-7-8-9-10-11-23-24-25-26-28-29) | - 1.0 | + 1.0 | μ A |
| 31 to 38 | Input Current Low Level 2 | I_{IL2} | 3009 | 4(a) | V_{IN} (Under Test) = 0V $V_{IN(\overline{CS})}$ = 0V V_{IN} (Remaining Inputs) = 5.5V V_{DD} = 5.5V, V_{SS} = 0V Note 2 (Pins D 9-10-11-13-14-15-16-17) (Pins C 13-14-15-18-19-20-21-22) | - 1.0 | + 1.0 | μ A |
| 39 to 52 | Input Current High Level 1 | I_{IH1} | 3010 | 4(b) | V_{IN} (Under Test) = 5.5V V_{IN} (Remaining Inputs) = 0V V_{DD} = 5.5V, V_{SS} = 0V (Pins D 1-2-3-4-5-6-7-8-18-19-20-21-22-23) (Pins C 4-5-6-7-8-9-10-11-23-24-25-26-28-29) | - 1.0 | + 1.0 | μ A |

NOTES: See Page 24.



TABLE 3 - ELECTRICAL MEASUREMENTS AT HIGH AND LOW TEMPERATURES (CONTINUED)

| NO. | CHARACTERISTICS | SYMBOL | TEST METHOD MIL-STD 883 | TEST FIG. | TEST CONDITIONS (PINS UNDER TEST D = DIP, C = CCP) | LIMITS | | UNIT |
|-----------|------------------------------------|-----------|-------------------------|-----------|---|--------|------|---------|
| | | | | | | MIN | MAX | |
| 53 to 60 | Input Current High Level 2 | I_{IH2} | 3010 | 4(b) | V_{IN} (Under Test) = 5.5V $V_{IN(\overline{OE})}$ = 5.5V V_{IN} (Remaining Inputs) = 0V V_{DD} = 5.5V, V_{SS} = 0V Note 2 (Pins D 9-10-11-13-14-15-16-17) (Pins C 13-14-15-18-19-20-21-22) | -1.0 | +1.0 | μ A |
| 61 to 68 | Output Voltage Low Level | V_{OL} | 3007 | 4(c) | V_{IL} = 0V, V_{IH} = 3.0V I_{OL} = 4.0mA, $V_{IN(\overline{W})}$ = 4.5V $V_{IN(\overline{CS})}$ = 0V, $V_{IN(\overline{OE})}$ = 0V V_{DD} = 4.5V, V_{SS} = 0V Note 3 (Pins D 9-10-11-13-14-15-16-17) (Pins C 13-14-15-18-19-20-21-22) | - | 0.4 | V |
| 69 to 76 | Output Voltage High Level | V_{OH} | 3006 | 4(d) | V_{IL} = 0V, V_{IH} = 3.0V I_{OH} = -1.0mA, $V_{IN(\overline{W})}$ = 4.5V $V_{IN(\overline{CS})}$ = 0V, $V_{IN(\overline{OE})}$ = 0V V_{DD} = 4.5V, V_{SS} = 0V Note 4 (Pins D 9-10-11-13-14-15-16-17) (Pins C 13-14-15-18-19-20-21-22) | 2.4 | - | V |
| 77 to 98 | Input Clamp Voltage (to V_{SS}) | V_{IC1} | - | 4(e) | I_{IN} (Under Test) = -100 μ A V_{DD} = Open, V_{SS} = 0V All Other Pins Open (Pins D 1-2-3-4-5-6-7-8-9-10-11-13-14-15-16-17-18-19-20-21-22-23) (Pins C 4-5-6-7-8-9-10-11-13-14-15-18-19-20-21-22-23-24-25-26-28-29) | -0.2 | -2.0 | V |
| 99 to 120 | Input Clamp Voltage (to V_{DD}) | V_{IC2} | - | 4(e) | I_{IN} (Under Test) = 100 μ A V_{DD} = 0V, V_{SS} = Open All Other Pins Open (Pins D 1-2-3-4-5-6-7-8-9-10-11-13-14-15-16-17-18-19-20-21-22-23) (Pins C 4-5-6-7-8-9-10-11-13-14-15-18-19-20-21-22-23-24-25-26-28-29) | 0.2 | 2.0 | |

NOTES: See Page 24.

**TABLE 3 - ELECTRICAL MEASUREMENTS AT HIGH AND LOW TEMPERATURES (CONTINUED)**

| NO. | CHARACTERISTICS | SYMBOL | TEST METHOD MIL-STD 883 | TEST FIG. | TEST CONDITIONS (PINS UNDER TEST D = DIP, C = CCP) | LIMITS | | UNIT |
|------------------|-------------------------------|------------|-------------------------------|-----------|---|--------|------|---------|
| | | | | | | MIN | MAX | |
| 121 | Supply Current (Operating) | I_{DDop} | 3005 | 4(f) | $V_{IN(\overline{OE})} = 0.8V$ V_{IN} (Remaining Inputs) = 0V to 3.0V $f = 2.5MHz$ Pattern: ICCACT $I_{OUT} = 0mA$ $V_{DD} = 5.5V, V_{SS} = 0V$ (Pin D 24) (Pin C 32) | - | 77.5 | mA |
| 122 | Supply Current (Enabled) | I_{DDE} | 3005 | 4(f) | $V_{IN(\overline{CS})} = 0.8V$ V_{IN} (Remaining Inputs) = 0.8V $I_{OUT} = 0mA$ $V_{DD} = 5.5V, V_{SS} = 0V$ (Pin D 24) (Pin C 32) | - | 70 | mA |
| 123 | Supply Current (Standby 1) | I_{DDB1} | 3005 | 4(f) | $V_{IN(\overline{CS})} = 2.2V$ V_{IN} (Remaining Inputs) = 0.8V $I_{OUT} = 0mA$ $V_{DD} = 5.5V, V_{SS} = 0V$ (Pin D 24) (Pin C 32) | - | 5.0 | mA |
| 124 to 127 | Supply Current (Standby 2) | I_{DDB2} | 3005 | 4(f) | $V_{IN(\overline{OE})} = V_{DD} - 0.3V$ V_{IN} (Remaining Inputs) = $V_{DD} - 0.3V$ to $-0.3V$ $I_{OUT} = 0mA$ $V_{DD} = 5.5V, V_{SS} = 0V$ Note 5 (Pin D 24) (Pin C 32) | - | 50 | μA |
| 128 | Data Retention Current | I_{DDDR} | 3005 | 4(g) | $V_{IL} = 0V, V_{IH} = 2.0V$ $V_{IN(\overline{CS})} = 2.0V$ $V_{DD} = 2.0V, V_{SS} = 0V$ Note 5 (Pin D 24) (Pin C 32) | - | 20 | μA |
| 129 to 130 | Data Retention | DR | - | - | $V_{IL} = 0V, V_{IH} = 3.0V$ $V_{IN(\overline{CS})} = 4.5V$ $V_{DD} = 4.5V, V_{SS} = 0V$ Note 6 (Pins D 9-10-11-12-13-14- 15-16-17) (Pins C 13-14-15-18-19-20- 21-22) | - | - | - |

NOTES: See Page 24.



FIGURE 4 - CIRCUITS FOR ELECTRICAL MEASUREMENTS

FIGURE 4(a) - INPUT CURRENT LOW LEVEL

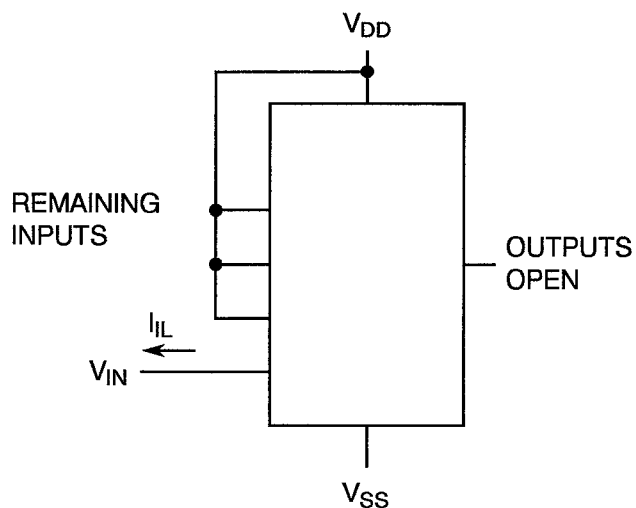

NOTES

- 1. Each input to be tested separately.

FIGURE 4(b) - INPUT CURRENT HIGH LEVEL

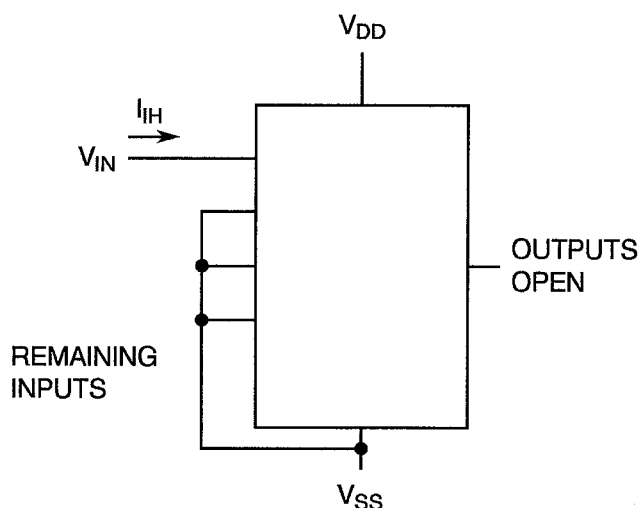

NOTES

- 1. Each input to be tested separately.

FIGURE 4(c) - OUTPUT VOLTAGE LOW LEVEL

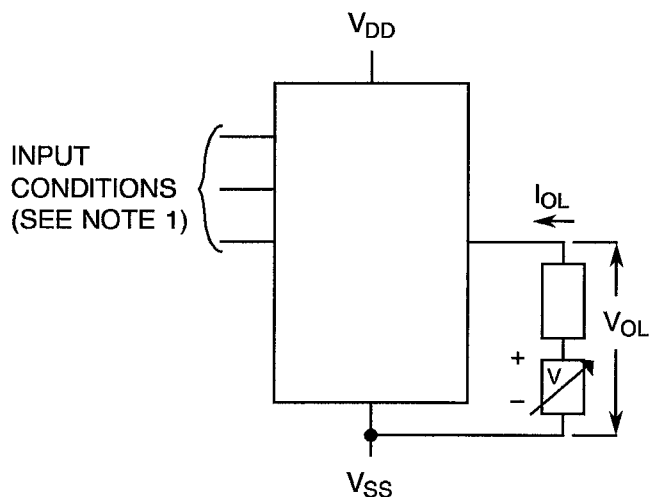

NOTES

- 1. $V_{IN} = V_{IL}$ (max.) and/or V_{IH} (min.) as per Truth Table to give V_{OL} .
- 2. Each output to be tested separately.

FIGURE 4(d) - OUTPUT VOLTAGE HIGH LEVEL

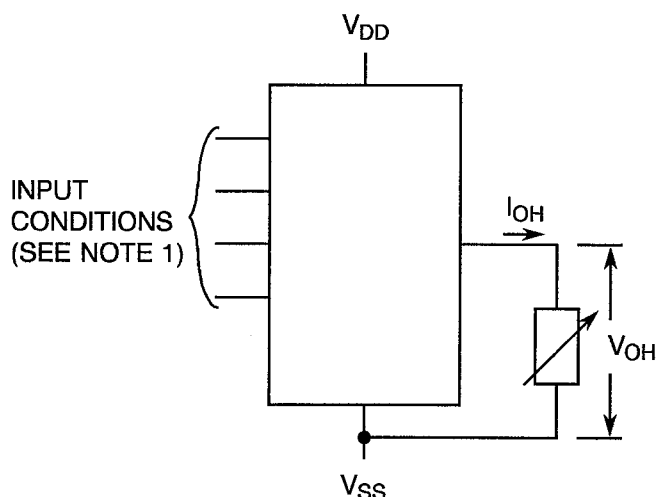

NOTES

- 1. $V_{IN} = V_{IL}$ (max.) and/or V_{IH} (min.) as per Truth Table to give V_{OH} .
- 2. Each output to be tested separately.



FIGURE 4 - CIRCUITS FOR ELECTRICAL MEASUREMENTS (CONTINUED)

FIGURE 4(e) - INPUT CLAMP VOLTAGE

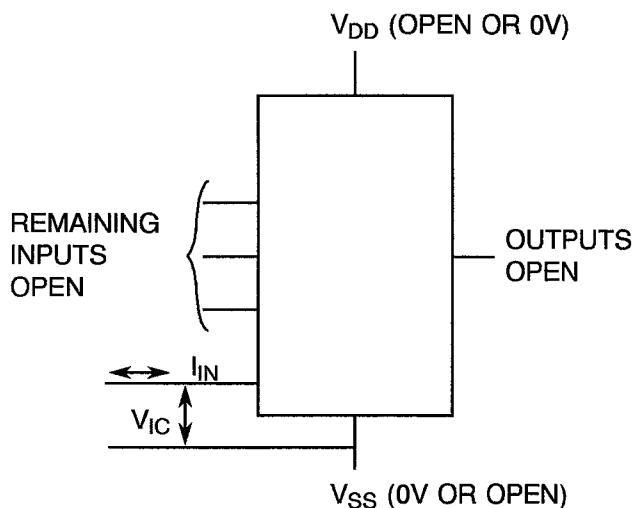

NOTES

1. Each input to be tested separately.

FIGURE 4(f) - SUPPLY CURRENT

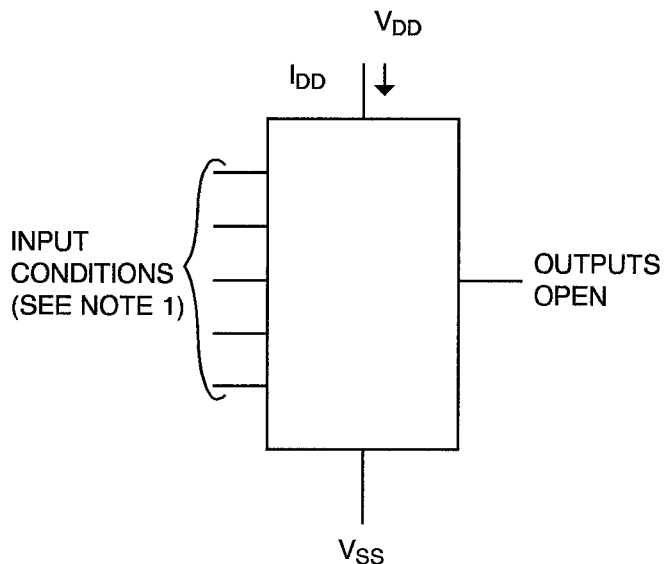

NOTES

1. As per Table 2 or 3.

FIGURE 4(g) - DATA RETENTION CURRENT

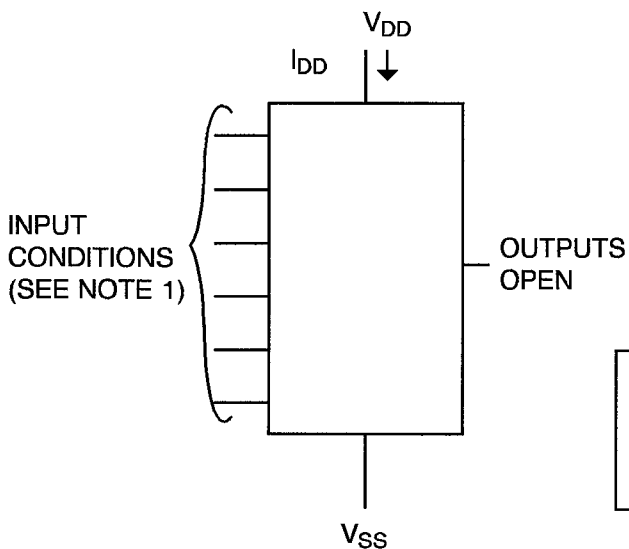

NOTES

1. Procedure as per Note 5 to Table 2.

FIGURE 4(h) - INPUT OR INPUT/OUTPUT CAPACITANCE

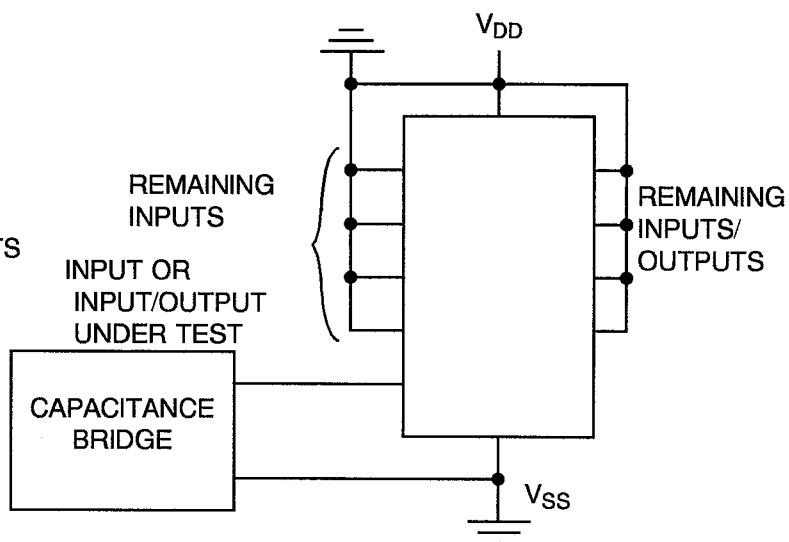

NOTES

1. Each input or input/output to be tested separately.
2. $f = 100\text{kHz to } 1\text{MHz}$.



FIGURE 4 - CIRCUITS FOR ELECTRICAL MEASUREMENTS (CONTINUED)

FIGURE 4(i) - PROPAGATION DELAY

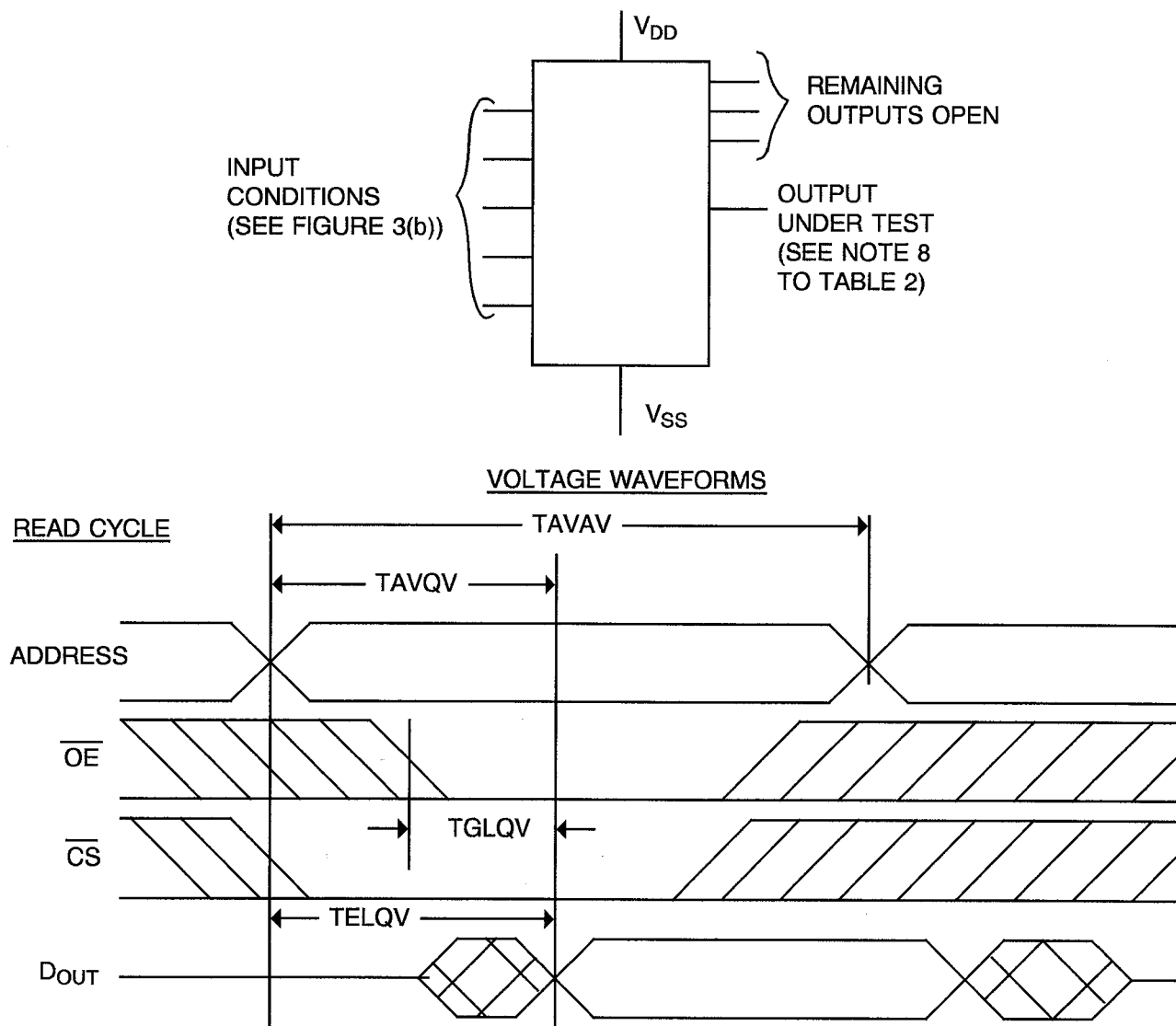

**TABLE 4 - PARAMETER DRIFT VALUES**

| NO. | CHARACTERISTICS | SYMBOL | SPEC. AND/OR TEST METHOD | TEST CONDITIONS | CHANGE LIMITS (Δ) | UNIT |
|------------|----------------------------|------------|--------------------------|-----------------|----------------------------|---------|
| 17 to 30 | Input Current Low Level 1 | I_{IL1} | As per Table 2 | As per Table 2 | ± 100 | nA |
| 31 to 38 | Input Current Low Level 2 | I_{IL2} | As per Table 2 | As per Table 2 | ± 100 | nA |
| 39 to 52 | Input Current High Level 1 | I_{IH1} | As per Table 2 | As per Table 2 | ± 100 | nA |
| 53 to 60 | Input Current High Level 2 | I_{IH2} | As per Table 2 | As per Table 2 | ± 100 | nA |
| 61 to 68 | Output Voltage Low Level | V_{OL} | As per Table 2 | As per Table 2 | ± 100 | mV |
| 69 to 76 | Output Voltage High Level | V_{OH} | As per Table 2 | As per Table 2 | ± 100 | mV |
| 123 | Supply Current (Standby 1) | I_{DDB1} | As per Table 2 | As per Table 2 | ± 0.5 | mA |
| 124 to 127 | Supply Current (Standby 2) | I_{DDB2} | As per Table 2 | As per Table 2 | ± 5.0 | μ A |
| 128 | Data Retention Current | I_{DDDR} | As per Table 2 | As per Table 2 | ± 5.0 | μ A |

**TABLE 5 - CONDITIONS FOR POWER BURN-IN AND OPERATING LIFE TEST**

| NO. | CHARACTERISTICS | SYMBOL | CONDITIONS | UNIT |
|-----|--|-----------|--|------|
| 1 | Ambient Temperature | T_{amb} | + 125(+ 0 - 5) | °C |
| 2 | Inputs - (Pins D 1-2-3-4-5-6-7-8-19-22-23) (Pins C 4-5-6-7-8-9-10-11-24-28-29) | V_{IN} | f_0 to f_{10} | Vac |
| 3 | Inputs - (Pins D 18-20-21) (Pins C 23-25-26) | V_{IN} | \overline{CS} , \overline{OE} , \overline{W} (Note 3) | Vac |
| 4 | Inputs/Outputs - (Pins D 9-10-11-13-14-15-16-17) (Pins C 13-14-15-18-19-20-21-22) | V_{IN} | f_{11} to f_{15} | Vac |
| 5 | Pulse Voltage | V_{GEN} | 0 to V_{DD} | Vac |
| 6 | Pulse Frequency | f_0 | 25k ± 20% 50 ± 15% Duty Cycle | Hz |
| 7 | Positive Supply Voltage (Pin D 24) (Pin C 32) | V_{DD} | 5.0(+ 0.5 - 0) | V |
| 8 | Negative Supply Voltage (Pin D 12) (Pin C 16) | V_{SS} | 0 | V |

NOTES

1. Input Protection Resistor $R1 = 1.0k\Omega$, $R2 = 2.2k\Omega$.
2. $f_n = \frac{1}{2}(f_n - 1)$.
3. Input Timing:

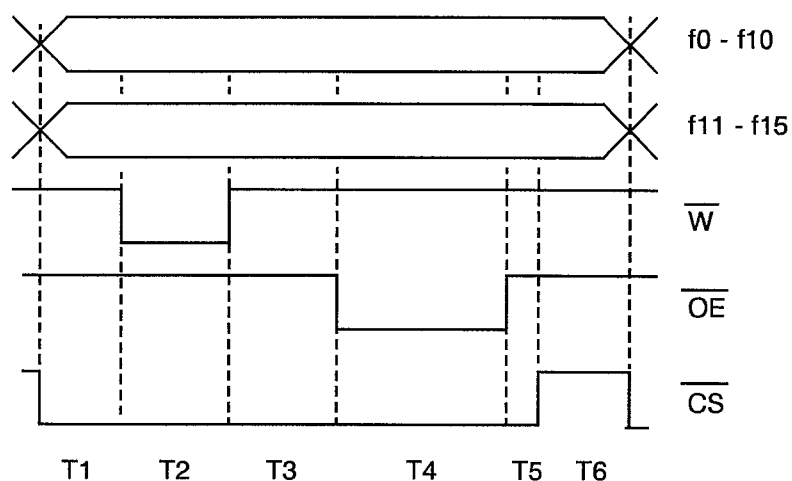

- $T_1 = 2.42 \mu s$
- $T_2 = 3.03 \mu s$
- $T_3 = 3.64 \mu s$
- $T_4 = 6.06 \mu s$
- $T_5 = 1.21 \mu s$
- $T_6 = T_2$



FIGURE 5 - ELECTRICAL CIRCUIT FOR POWER BURN-IN AND OPERATING LIFE TEST

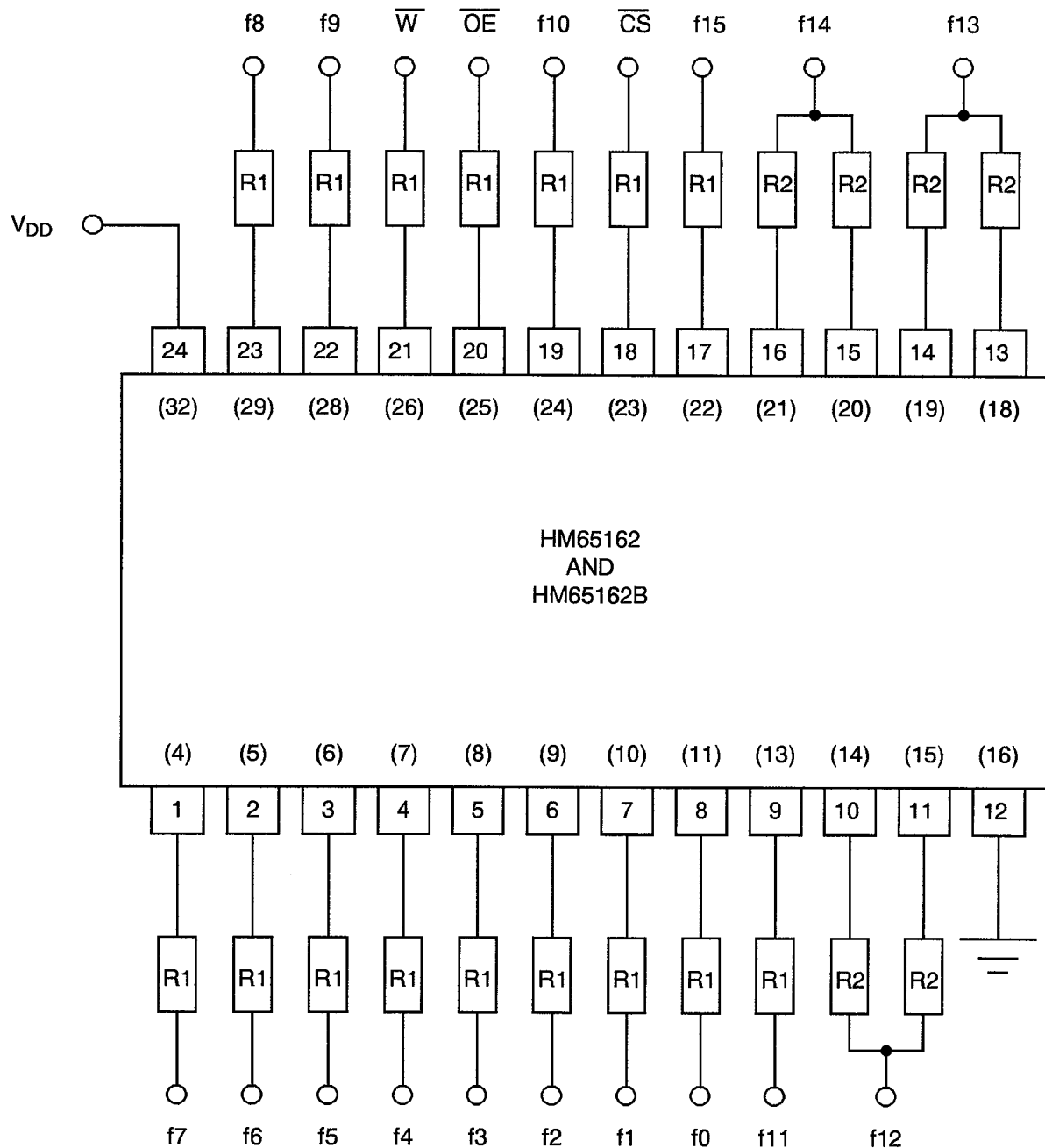

NOTES

1. Pin numbers in parenthesis are for the chip carrier package.



- 4.8 ENVIRONMENTAL AND ENDURANCE TESTS (CHARTS IV AND V OF ESA/SCC GENERIC SPECIFICATION No. 9000)
- 4.8.1 Electrical Measurements on Completion of Environmental Tests
The parameters to be measured on completion of environmental tests are scheduled in Table 2. Unless otherwise stated, the measurements shall be performed at $T_{amb} = +22 \pm 3$ °C.
- 4.8.2 Electrical Measurements at Intermediate Points during Endurance Tests
The parameters to be measured at intermediate points during endurance testing are as scheduled in Table 6 of this specification. Unless otherwise stated, the measurements shall be performed at $T_{amb} = +22 \pm 3$ °C.
- 4.8.3 Electrical Measurements on Completion of Endurance Tests
The parameters to be measured on completion of endurance testing are as scheduled in Table 6 of this specification. Unless otherwise stated, the measurements shall be performed at $T_{amb} = +22 \pm 3$ °C.
- 4.8.4 Conditions for Operating Life Tests
The requirements for operating life testing are specified in Section 9 of ESA/SCC Generic Specification No. 9000. The conditions for operating life testing shall be as specified in Table 5(c) of this specification.
- 4.8.5 Electrical Circuits for Operating Life Tests
Circuits for use in performing the operating life tests are shown in Figure 5(c) of this specification.
- 4.8.6 Conditions for High Temperature Storage Test
The requirements for the high temperature storage test are specified in ESA/SCC Generic Specification No. 9000. The temperature to be applied shall be the maximum storage temperature specified in Table 1(b) of this specification.
- 4.9 TOTAL DOSE IRRADIATION TESTING
- 4.9.1 Application
If specified in Para. 4.2.1 of this specification, total dose irradiation testing shall be performed in accordance with the requirements of ESA/SCC Basic Specification No. 22900.
- 4.9.2 Bias Conditions
Continuous bias shall be applied during irradiation testing as shown in Figure 6 of this specification.
- 4.9.3 Electrical Measurements
The parameters to be measured prior to irradiation exposure are scheduled in Table 2 of this specification. Only devices which meet the requirements of Table 2 shall be included in the test sample.

The parameters to be measured during and on completion of irradiation testing are scheduled in Table 7 of this specification.

**TABLE 6 - ELECTRICAL MEASUREMENTS AT INTERMEDIATE POINTS AND ON COMPLETION OF ENDURANCE TESTING**

| NO. | CHARACTERISTICS | SYMBOL | SPEC. AND/OR TEST METHOD | TEST CONDITIONS | LIMITS | | UNIT |
|-----------|--|------------|--------------------------|-----------------|--------|------|---------|
| | | | | | MIN | MAX | |
| 1 to 6 | Functional Test 1 (Nominal Inputs) | - | As per Table 2 | As per Table 2 | - | - | - |
| 7 | Functional Test 2 (Worst Case Inputs) | - | As per Table 2 | As per Table 2 | - | - | - |
| 8 to 16 | Functional Test 3 (Worst Case Outputs) | - | As per Table 2 | As per Table 2 | - | - | - |
| 17 to 30 | Input Current Low Level 1 | I_{IL1} | As per Table 2 | As per Table 2 | -1.0 | +1.0 | μA |
| 31 to 38 | Input Current Low Level 2 | I_{IL2} | As per Table 2 | As per Table 2 | -1.0 | +1.0 | μA |
| 39 to 52 | Input Current High Level 1 | I_{IH1} | As per Table 2 | As per Table 2 | -1.0 | +1.0 | μA |
| 53 to 60 | Input Current High Level 2 | I_{IH2} | As per Table 2 | As per Table 2 | -1.0 | +1.0 | μA |
| 61 to 68 | Output Voltage Low Level | V_{OL} | As per Table 2 | As per Table 2 | - | 0.4 | V |
| 69 to 76 | Output Voltage High Level | V_{OH} | As per Table 2 | As per Table 2 | 2.4 | - | V |
| 77 to 98 | Input Clamp Voltage (to V_{SS}) | V_{IC1} | As per Table 2 | As per Table 2 | -0.2 | -2.0 | V |
| 99 to 120 | Input Clamp Voltage (to V_{DD}) | V_{IC2} | As per Table 2 | As per Table 2 | 0.2 | 2.0 | V |
| 121 | Supply Current (Operating) | I_{DDop} | As per Table 2 | As per Table 2 | - | 77.5 | mA |
| 122 | Supply Current (Enabled) | I_{DDE} | As per Table 2 | As per Table 2 | - | 70 | mA |

**TABLE 6 - ELECTRICAL MEASUREMENTS AT INTERMEDIATE POINTS AND ON COMPLETION OF ENDURANCE TESTING (CONTINUED)**

| NO. | CHARACTERISTICS | SYMBOL | SPEC. AND/OR TEST METHOD | TEST CONDITIONS | LIMITS | | UNIT |
|------------|----------------------------|--------------------|--------------------------|-----------------|--------|-----|------|
| | | | | | MIN | MAX | |
| 123 | Supply Current (Standby 1) | I _{DDSB1} | As per Table 2 | As per Table 2 | - | 5.0 | mA |
| 124 to 127 | Supply Current (Standby 2) | I _{DDSB2} | As per Table 2 | As per Table 2 | - | 50 | μA |
| 128 | Data Retention Current | I _{DDDR} | As per Table 2 | As per Table 2 | - | 20 | μA |
| 129 to 130 | Data Retention | DR | As per Table 2 | As per Table 2 | - | - | - |



FIGURE 6 - BIAS CONDITIONS FOR IRRADIATION TESTING

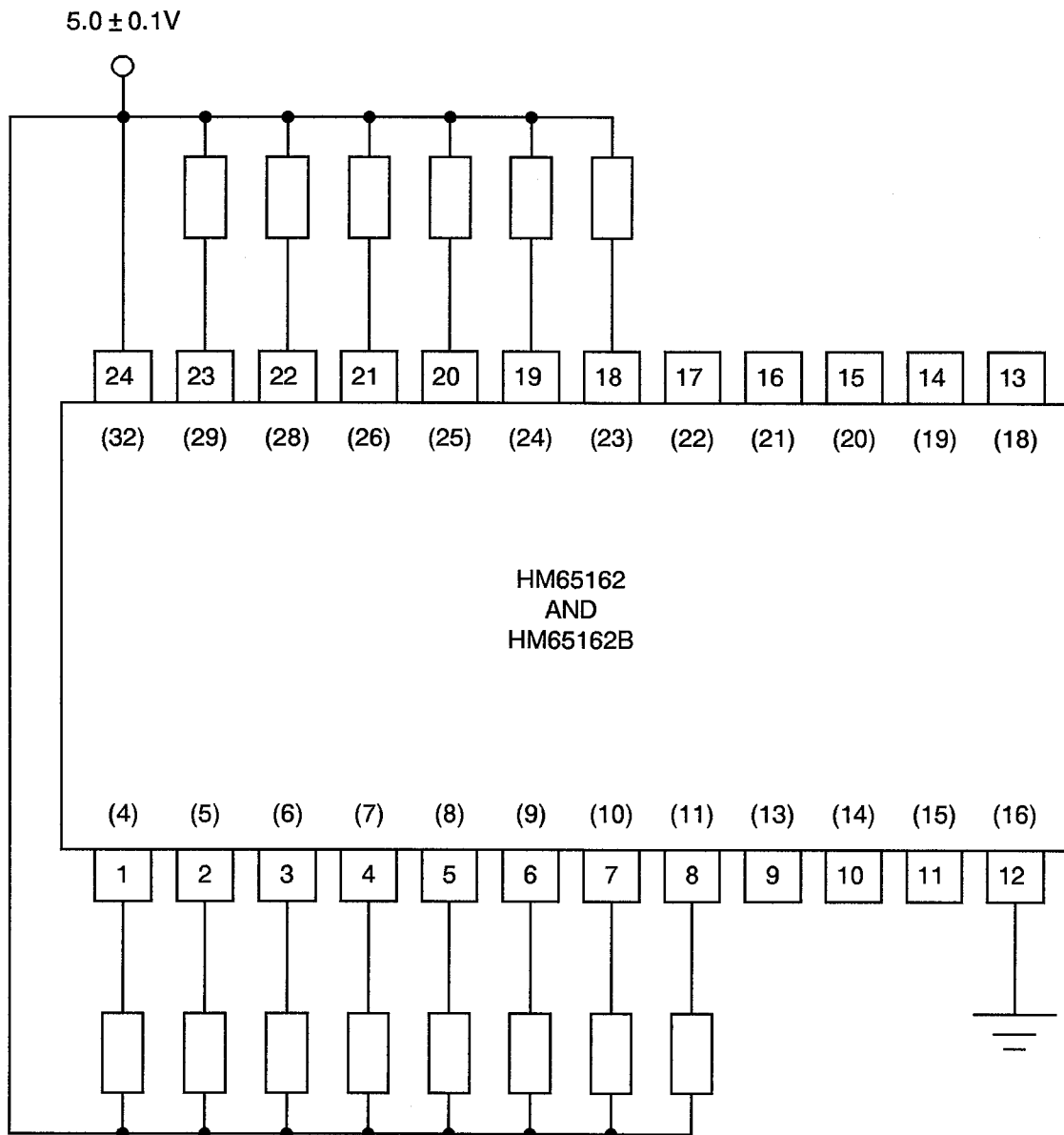

NOTES

1. Input Protection Resistor = 1.0kΩ.
2. Pin numbers in parenthesis are for the chip carrier package.

**TABLE 7 - ELECTRICAL MEASUREMENTS DURING AND ON COMPLETION OF IRRADIATION TESTING**

| No. | CHARACTERISTICS | SYMBOL | SPEC. AND/OR TEST METHOD | TEST CONDITIONS | ABSOLUTE | | UNIT |
|------------|------------------------------------|-------------|--------------------------|-----------------|----------|-------|---------|
| | | | | | MIN | MAX | |
| 1 to 6 | Functional Test 1 (Nominal Inputs) | - | As per Table 2 | As per Table 2 | - | - | - |
| 17 to 30 | Input Current Low Level 1 | I_{IL1} | As per Table 2 | As per Table 2 | - 1. | + 1.0 | μA |
| 31 to 38 | Input Current Low Level 2 | I_{IL2} | As per Table 2 | As per Table 2 | - 1.0 | + 1.0 | μA |
| 39 to 52 | Input Current High Level 1 | I_{IH1} | As per Table 2 | As per Table 2 | - 1.0 | + 1.0 | μA |
| 53 to 60 | Input Current High Level 2 | I_{IH2} | As per Table 2 | As per Table 2 | - 1.0 | + 1.0 | μA |
| 61 to 68 | Output Voltage Low Level | V_{OL} | As per Table 2 | As per Table 2 | - | 0.4 | V |
| 69 to 76 | Output Voltage High Level | V_{OH} | As per Table 2 | As per Table 2 | 2.4 | - | V |
| 124 to 127 | Supply Current (Standby 2) | I_{DDSB2} | As per Table 2 | As per Table 2 | - | 1.0 | mA |

**APPENDIX 'A'**

Page 1 of 4

AGREED DEVIATIONS FOR MATRA-HARRIS (F)

The following test patterns may be used:-

ICCACT Pattern

- (a) Write loop pattern between N min. and N max.

WALKOL Pattern

- (a) Write a column of ones on a background of zeros.
(b) Read the column and background, step the column and repeat the read.
(c) Continue until all columns have been used.
(d) Repeat with data complement.
(e) 4YN + 2Y + 2 cycles.

CHIP DESELECT Pattern

- (a) Write 0 background \overline{CS} at VIL.
(b) Write 1 background \overline{CS} at VIL.
(c) Read 1 background \overline{CS} at VIL.
(d) Write 0 background \overline{CS} at VIH.
(e) Read 1 background CS at VIL.

GENBL Pattern

- (a) Write 0 background.
(b) Write 1 background.
(c) Read 1 background \overline{OE} at VIL.
(d) Read 1 background \overline{OE} at VIH.

LONG CHIP SELECT Pattern

Checkerboard pattern with timing unspecified.



APPENDIX 'A'

COMARCH Pattern

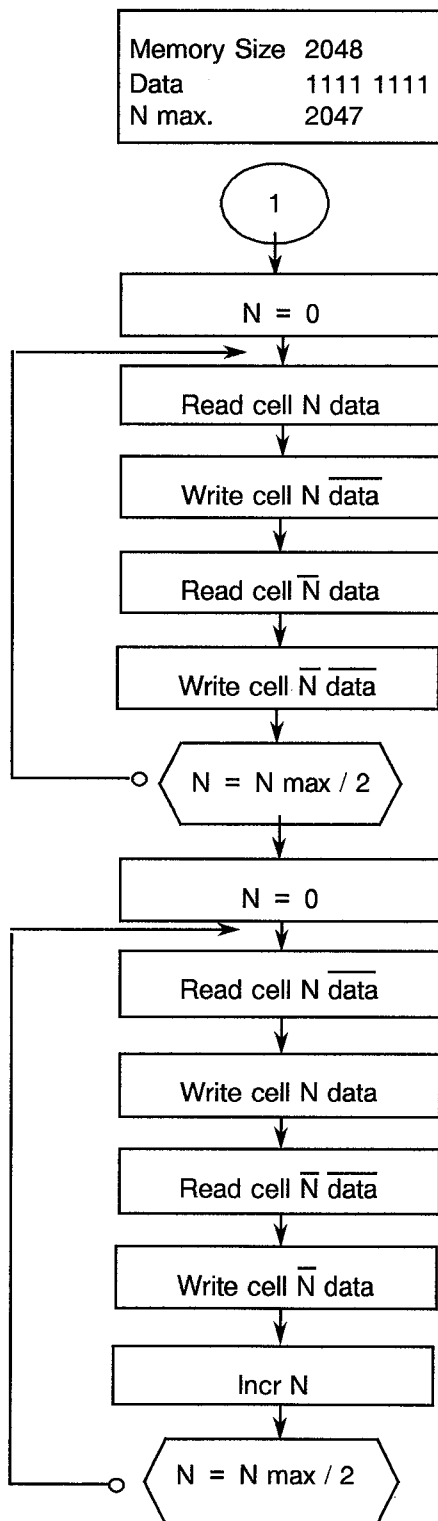
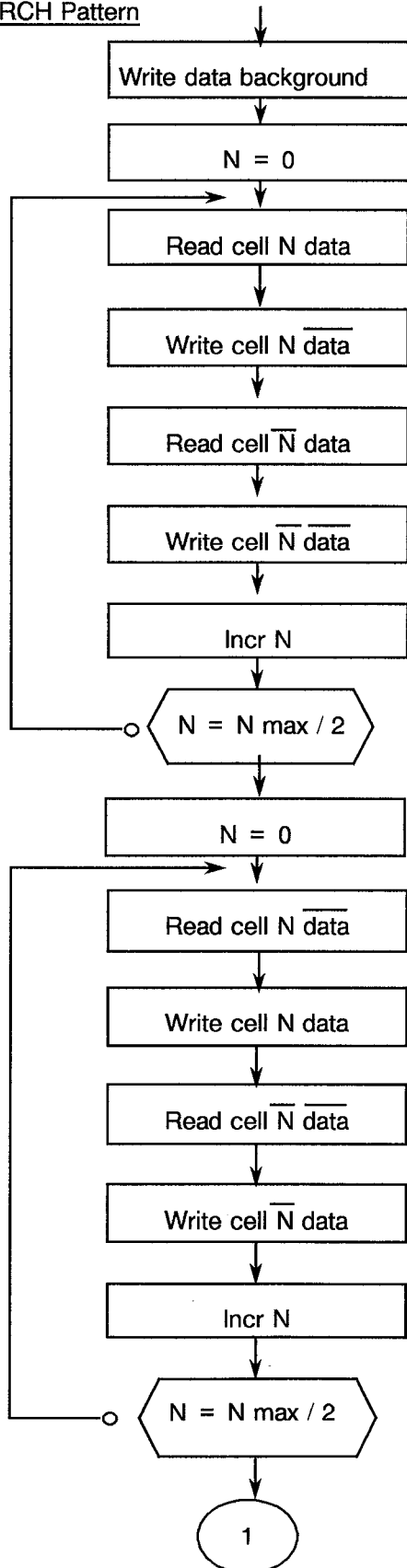



APPENDIX 'A'

MARCH Pattern

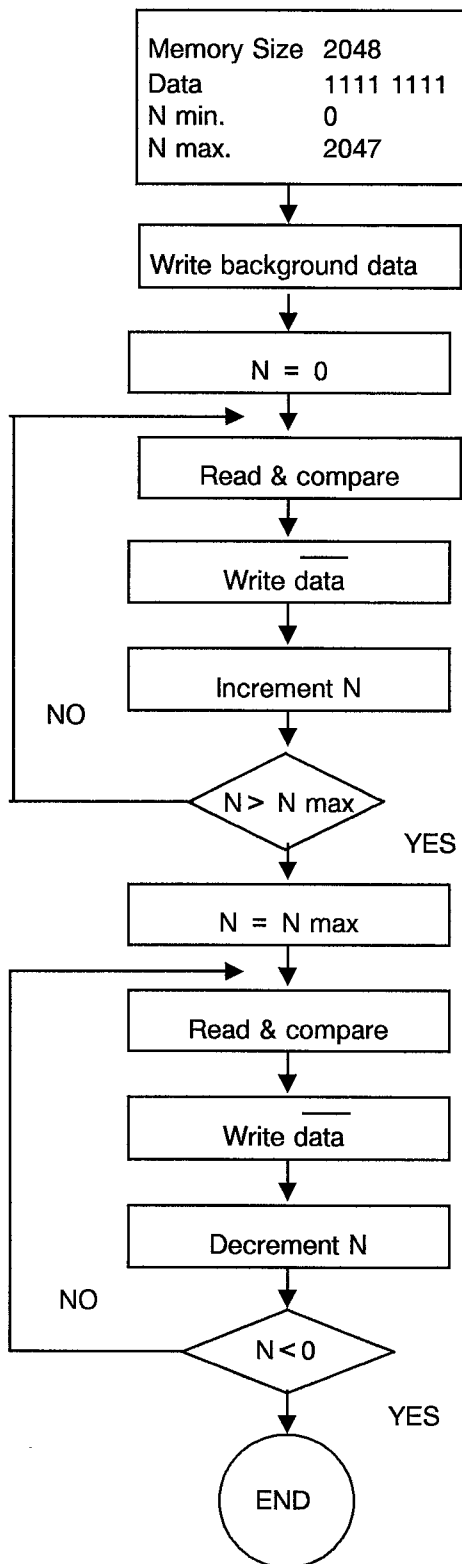



APPENDIX 'A'

CHECKERBOARD Pattern

