



europaean space agency
agence spatiale européenne

Pages 1 to 50

INTEGRATED CIRCUITS, SILICON MONOLITHIC,
CMOS SILICON GATE, STATIC, 64K (65536 x 1 BIT)

ASYNCHRONOUS RANDOM ACCESS MEMORY

WITH 3-STATE OUTPUTS,

BASED ON TYPE HM65687

ESA/SCC Detail Specification No. 9301/026



space components
coordination group

Issue/Rev.	Date	Approved by	
		SCCG Chairman	ESA Director General or his Deputy
Issue 1	October 1992	<i>Pommes</i>	<i>J. L. ...</i>
Revision 'A'	July 1993	<i>Pommes</i>	<i>J. L. ...</i>



ESA/SCC Detail Specification
No. 9301/026

Rev. 'A'

PAGE 2

ISSUE 1

DOCUMENTATION CHANGE NOTICE

Rev. Letter	Rev. Date	Reference	CHANGE Item	Approved DCR No.
'A'	July '93	P1	Cover Page	None
		P2	DCN	None
		P20	Table 2 : Nos. 17 to 35 and Nos. 36 to 54, minimum limit amended	23576
		P21	Table 2 : No. 76 and No. 77 , minimum limit amended	23576
		P28	Table 3 : Nos. 17 to 35 and Nos. 36 to 54, minimum limit amended	23576
		P29	Table 3 : No. 76 and No. 77 , minimum limit amended	23576
		P43	Table 6 : Nos. 17 to 35, Nos. 36 to 54, No. 76 and No. 77 minimum limit amended	23576
		P46	Table 7 : Nos. 17 to 35, Nos. 36 to 54, No. 76 and No. 77 minimum limit amended	23576



 	<p style="text-align: center;">ESA/SCC Detail Specification No. 9301/026</p>		<p>PAGE 3 ISSUE 1</p>
---	--	--	---------------------------

TABLE OF CONTENTS

		<u>Page</u>
1.	<u>GENERAL</u>	5
1.1	Scope	5
1.2	Component Type Variants	5
1.3	Maximum Ratings	5
1.4	Parameter Derating Information	5
1.5	Physical Dimensions	5
1.6	Pin Assignment	5
1.7	Truth Table	5
1.8	Circuit Schematic	5
1.9	Functional Diagram	5
1.10	Handling Precautions	5
1.11	Input Protection Network	5
2.	<u>APPLICABLE DOCUMENTS</u>	16
3.	<u>TERMS, DEFINITIONS, ABBREVIATIONS, SYMBOLS AND UNITS</u>	16
4.	<u>REQUIREMENTS</u>	16
4.1	General	16
4.2	Deviations from Generic Specification	17
4.2.1	Deviations from Special In-process Controls	17
4.2.2	Deviations from Final Production Tests	17
4.2.3	Deviations from Burn-in Tests	17
4.2.4	Deviations from Qualification Tests	17
4.2.5	Deviations from Lot Acceptance Tests	17
4.3	Mechanical Requirements	17
4.3.1	Dimension Check	17
4.3.2	Weight	17
4.4	Materials and Finishes	17
4.4.1	Case	17
4.4.2	Lead Material and Finish	17
4.5	Marking	18
4.5.1	General	18
4.5.2	Lead Identification	18
4.5.3	The SCC Component Number	18
4.5.4	Traceability Information	18
4.6	Electrical Measurements	18
4.6.1	Electrical Measurements at Room Temperature	18
4.6.2	Electrical Measurements at High and Low Temperatures	18
4.6.3	Circuits for Electrical Measurements	18
4.7	Burn-in Tests	19
4.7.1	Parameter Drift Values	19
4.7.2	Conditions for Power Burn-in	19
4.7.3	Electrical Circuits for Power Burn-in	19
4.8	Environmental and Endurance Tests	42
4.8.1	Electrical Measurements on Completion of Environmental Tests	42
4.8.2	Electrical Measurements at Intermediate Points during Endurance Tests	42
4.8.3	Electrical Measurements on Completion of Endurance Tests	42
4.8.4	Conditions for Operating Life Tests	42
4.8.5	Electrical Circuits for Operating Life Tests	42
4.8.6	Conditions for High Temperature Storage Test	42

	<p style="text-align: center;">ESA/SCC Detail Specification No. 9301/026</p>		<p>PAGE 4 ISSUE 1</p>
---	--	--	---------------------------

	<u>Page</u>
4.9 Total Dose Irradiation Testing	42
4.9.1 Application	42
4.9.2 Bias Conditions	42
4.9.3 Electrical Measurements	42

TABLES

1(a) Type Variants	6
1(b) Maximum Ratings	7
2 Electrical Measurements at Room Temperature - d.c. Parameters	20
Electrical Measurements at Room Temperature - a.c. Parameters	23
3 Electrical Measurements at High and Low Temperatures - d.c. Parameters	28
Electrical Measurements at High and Low Temperatures - a.c. Parameters	31
4 Parameter Drift Values	39
5 Conditions for Power Burn-in and Operating Life Test	40
6 Electrical Measurements at Intermediate Points and on Completion of Endurance Testing	43
7 Electrical Measurements During and on Completion of Irradiation Testing	46

FIGURES

1 Not applicable	N/A
2 Physical Dimensions	8
3(a) Pin Assignment	12
3(b) Truth Table	13
3(c) Circuit Schematic	15
3(d) Functional Diagram	15
3(e) Input Protection Network	15
4 Circuits for Electrical Measurements	28
5 Electrical Circuit for Power Burn-in and Operating Life Test	41
6 Bias Conditions for Irradiation Testing	45

APPENDICES (Applicable to specific Manufacturers only)

'A' AGREED DEVIATIONS FOR MATRA-MHS (F)	47
---	----

	<p style="text-align: center;">ESA/SCC Detail Specification No. 9301/026</p>	<p>PAGE 5 ISSUE 1</p>
---	--	---------------------------

1. **GENERAL**

1.1 **SCOPE**

This specification details the ratings, physical and electrical characteristics, test and inspection data for a silicon, monolithic, CMOS Silicon Gate, Static, 64K (65536 x 1 BIT) Asynchronous Random Access Memory with 3-State Outputs, based on Type HM65687. It shall be read in conjunction with ESA/SCC Generic Specification No. 9000, the requirements of which are supplemented herein.

1.2 **COMPONENT TYPE VARIANTS**

Variants of the basic type integrated circuits specified herein, which are also covered by this specification, are given in Table 1(a).

1.3 **MAXIMUM RATINGS**

The maximum ratings, which shall not be exceeded at any time during use or storage, applicable to the integrated circuits specified herein, are as scheduled in Table 1(b).

1.4 **PARAMETER DERATING INFORMATION (FIGURE 1)**

Not applicable.

1.5 **PHYSICAL DIMENSIONS**

As per Figure 2.

1.6 **PIN ASSIGNMENT**

As per Figure 3(a).

1.7 **TRUTH TABLE**

As per Figure 3(b).

1.8 **CIRCUIT SCHEMATIC**

As per Figure 3(c).

1.9 **FUNCTIONAL DIAGRAM**

As per Figure 3(d).

1.10 **HANDLING PRECAUTIONS**

These devices are susceptible to damage by electrostatic discharge. Therefore, suitable precautions shall be employed for protection during all phases of manufacture, testing, packaging, shipment and any handling.

These components are categorised as Class 1 with a Minimum Critical Path Failure Voltage of 1 000 Volts.

1.11 **INPUT PROTECTION NETWORK**

Double transistor protection shall be incorporated into each input as shown in Figure 3(e).

**TABLE 1(a) - TYPE VARIANTS**

VARIANT	BASED ON TYPE	CASE	FIGURE	LEAD MATERIAL AND/OR FINISH
01	HM65687	DIL	2(a)	D7
02	HM65687	DIL	2(b)	G3
03	HM65687	CCP	2(c)	7
04	HM65687B	DIL	2(a)	D7
05	HM65687B	DIL	2(b)	G3
06	HM65687B	CCP	2(c)	7
07	HM65687C	DIL	2(a)	D7
08	HM65687C	DIL	2(b)	G3
09	HM65687C	CCP	2(c)	7
10	HM65687S	DIL	2(a)	D7
11	HM65687S	DIL	2(b)	G3
12	HM65687S	CCP	2(c)	7

TABLE 1(b) - MAXIMUM RATINGS

NO.	CHARACTERISTICS	SYMBOL	MAXIMUM RATINGS	UNITS	REMARKS
1	Supply Voltage	V_{DD}	-0.5 to +7.0	V	Note 1
2	Input Voltage	V_{IN}	-0.3 to $V_{DD} + 0.3$	V	Note 2 Power On
3	Output Current	$\pm I_{OUT}$	$V_{OUT} = V_{DD}$: +100 $V_{OUT} = V_{SS}$: -40	mA mA	Note 3
4	Device Dissipation (Continuous)	P_D	560	mW	Per Package
5	Operating Temperature Range	T_{op}	-55 to +125	°C	T_{amb}
6	Storage Temperature Range	T_{stg}	-65 to +165	°C	
7	Soldering Temperature For DIL For CCP	T_{sol}	+265 +265	°C	Note 4 Note 5
8	Thermal Resistance Variants 1-4-7-10 Variants 2-5-8-11 Variants 3-6-9-12	$R_{TH(J-A)}$	36 39 55	°C/W	
9	Junction Temperature	T_J	165	°C	

NOTES

1. Device is functional from +4.5V to +5.5V with reference to Ground.
2. $V_{DD} + 0.3V$ should not exceed +7.0V.
3. The maximum output current of any single output.
4. Duration 10 seconds maximum at a distance of not less than 1.5mm from the device body and the same lead shall not be resoldered until 3 minutes have elapsed.
5. Duration 5 seconds maximum and the same terminal shall not be resoldered until 3 minutes have elapsed.

FIGURE 1 - PARAMETER DERATING INFORMATION

Not applicable



FIGURE 2 - PHYSICAL DIMENSIONS

FIGURE 2(a) - DUAL-IN-LINE PACKAGE, 22 PIN

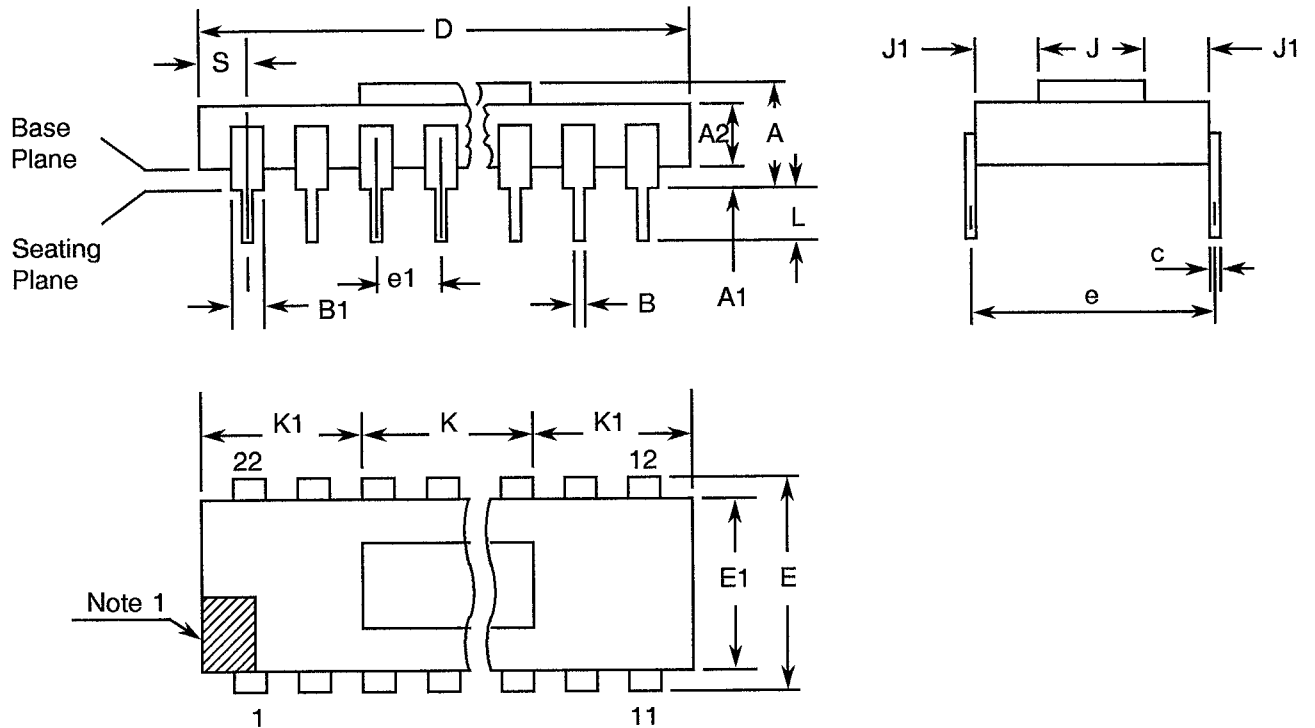

SYMBOL	MILLIMETERS		NOTES
	MIN.	MAX.	
A	2.82	3.94	
A1	0.63	1.14	3
A2	1.93	2.51	
B	0.38	0.53	8
B1	0.96	1.52	8
c	0.20	0.30	8
D	27.43	28.45	
E	7.49	8.25	4
E1	7.49 TYPICAL		
e	7.62 TYPICAL		
e1	2.54 TYPICAL		6,9
J	6.85 TYPICAL		
J1	0.31 TYPICAL		
K	14.35 TYPICAL		
K1	5.52 TYPICAL		
L	3.18	4.44	8
S	1.10	2.03	7

NOTES: See Page 11.



FIGURE 2 - PHYSICAL DIMENSIONS (CONTINUED)

FIGURE 2(b) - DUAL-IN-LINE PACKAGE, 22 PIN

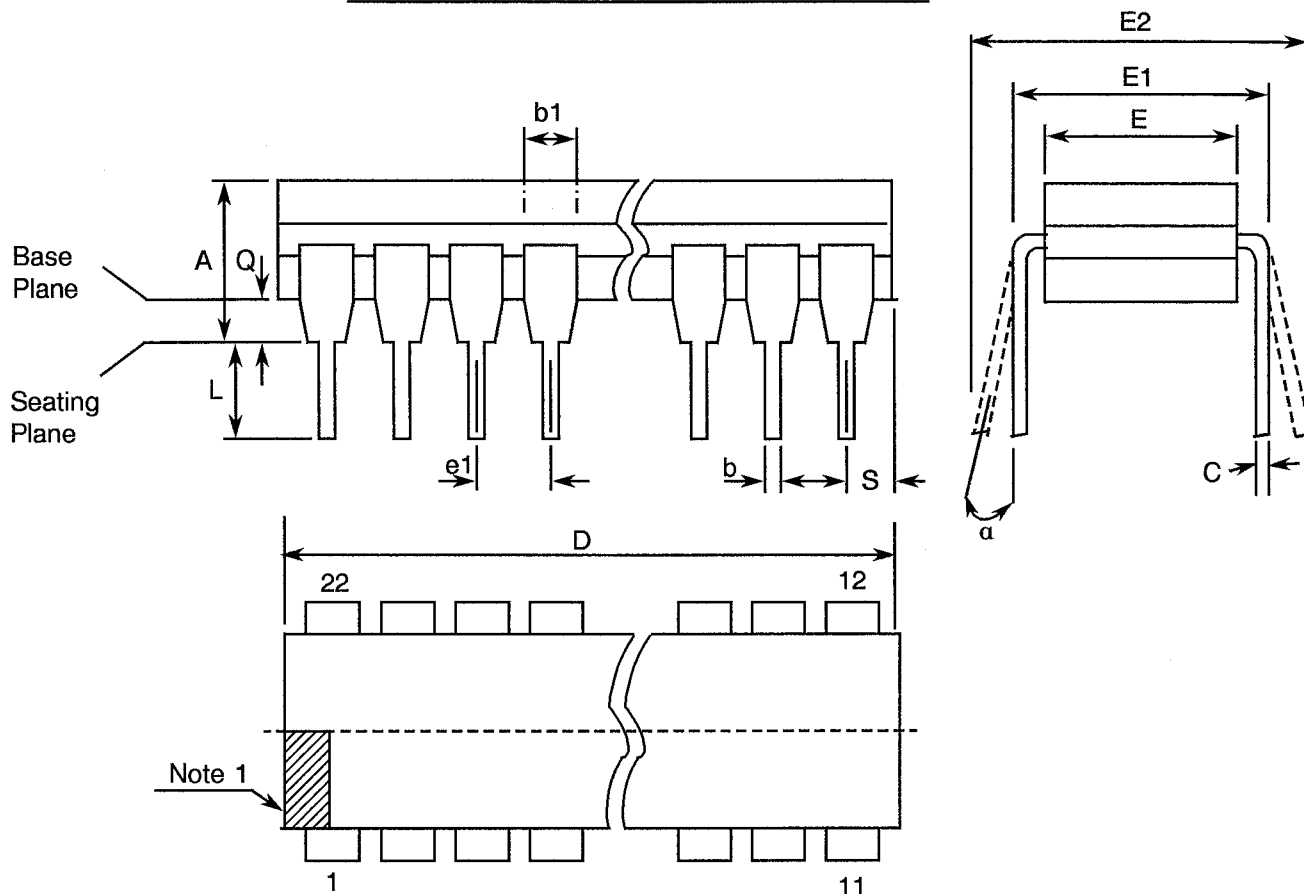

SYMBOL	MILLIMETERS		NOTES
	MIN.	MAX.	
A	-	5.84	
b	0.36	0.58	8
b1	0.89	1.78	8
C	0.20	0.38	8
D	26.92	28.19	
E	7.24	7.87	4
E1	7.82	8.00	
E2	-	10.82	
e1	2.54 TYPICAL		6,9
L	3.05	5.08	8
Q	0.51	-	3
S	0.58	2.60	7
α	0°	15°	

NOTES: See Page 11.



FIGURE 2 - PHYSICAL DIMENSIONS (CONTINUED)

FIGURE 2(c) - CHIP CARRIER, 22-TERMINAL

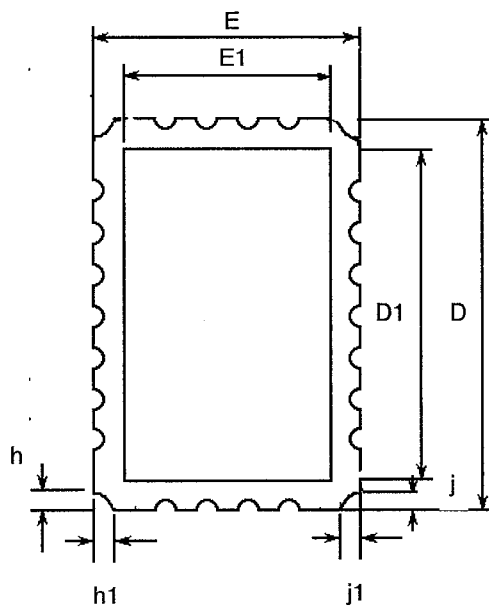
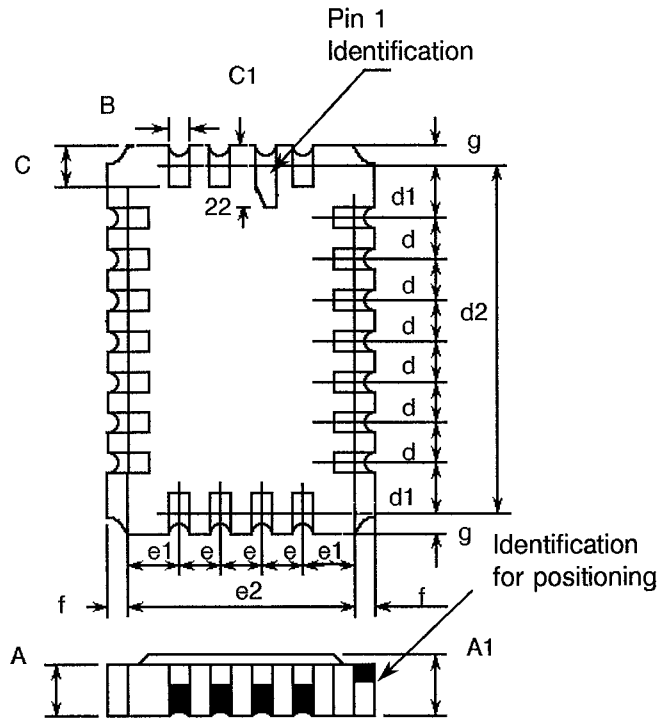

SYMBOL	MILLIMETRES		NOTES
	MIN	MAX	
A	1.37	1.68	
A1	1.62	1.93	
B	0.55	0.71	8
C	0.99	1.30	8
C1	1.98	2.34	
D	12.31	12.57	
D1	12.06 TYPICAL		
d	1.27 TYPICAL		5, 9
d1	1.71	1.97	5, 9
d2	11.3 TYPICAL		
E	7.23	7.50	
E1	6.98 TYPICAL		
e	1.27 TYPICAL		5, 9
e1	1.07	1.33	5, 9
e2	6.22 TYPICAL		
f, g	0.57 TYPICAL		
h, h1	0.30 TYPICAL		10
j, j1	0.30 TYPICAL		11

	<p style="text-align: center;">ESA/SCC Detail Specification No. 9301/026</p>		<p>PAGE 11 ISSUE 1</p>
---	--	--	----------------------------

FIGURE 2 - PHYSICAL DIMENSIONS (CONTINUED)

NOTES TO FIGURES 2(a) TO 2(c) INCLUSIVE

1. Index area: a notch, letter or dot shall be located adjacent to Pin 1 and shall be within the shaded area shown. For chip carrier packages the index shall be as defined in Figure 2(c).
2. Not applicable.
3. The dimension shall be measured from the seating plane to the base plane.
4. The dimension allows for off-centre lids, meniscus and glass overrun.
5. The true position pin or terminal spacing is 1.27mm between centrelines. Each pin or terminal centreline shall be located within 0.13mm of its true longitudinal position relative to Pin 1 and the highest pin number.
6. The true position pin spacing is 2.54mm between centrelines. Each pin centreline shall be located within 0.25mm of its true longitudinal position relative to Pin 1 and the highest pin number.
7. Applies to all 4 corners.
8. All leads or terminals.
9. 20 spaces for dual-in-line packages.
18 spaces for chip carrier packages.
10. 3 non-index corners - 6 dimensions.
11. Index corner only - 2 dimensions.



FIGURE 3(a) - PIN ASSIGNMENT

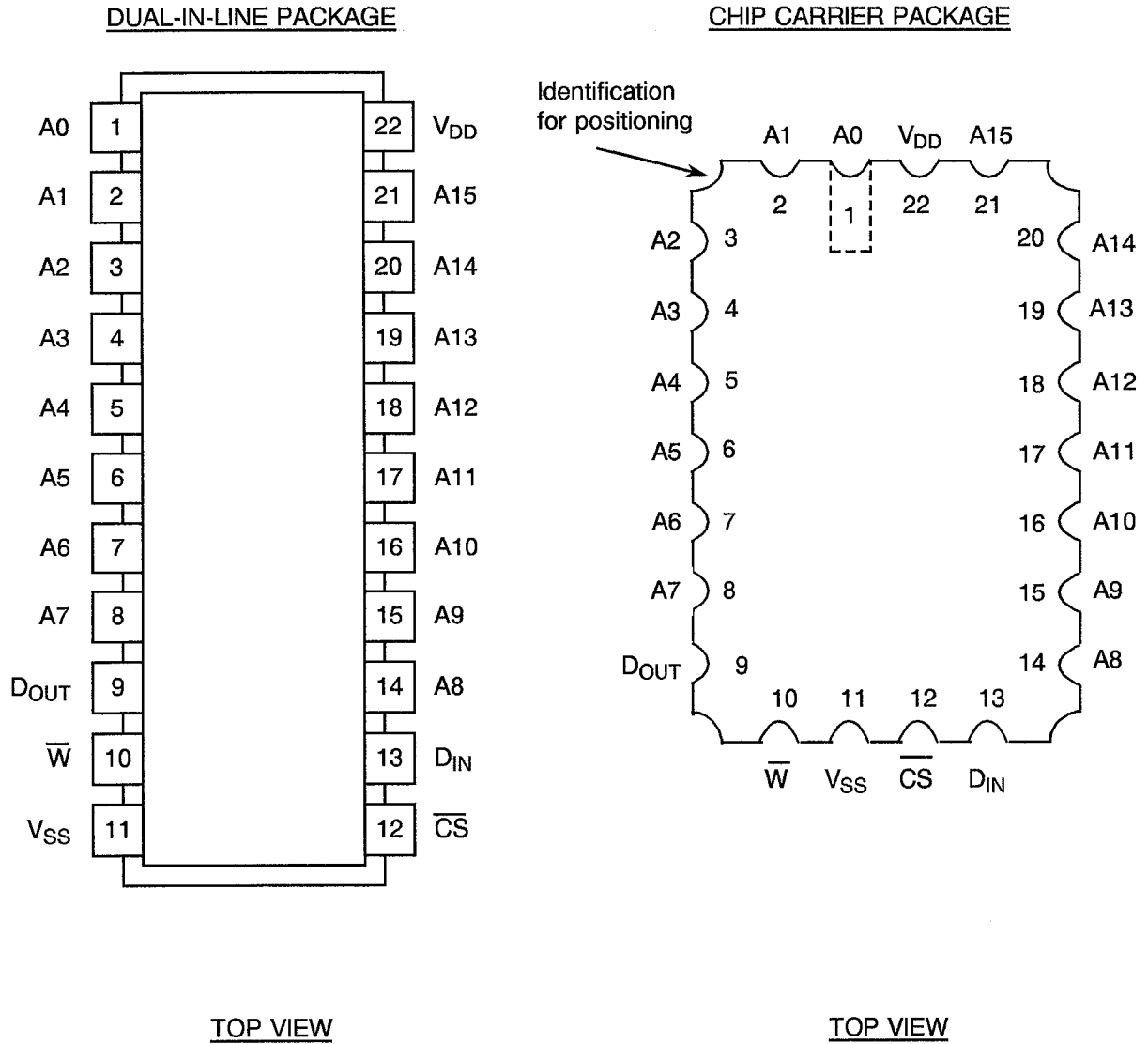

NOTES

1. A0 to A15 = Address Inputs
2. D_{IN} = Data Inputs
3. \overline{W} = Write Enable
4. \overline{CS} = Chip Select
5. D_{OUT} = Data Output

FIGURE 3(b) - TRUTH TABLE

\overline{CS}	\overline{W}	D_{IN}	D_{OUT}	MODE
H	X	Z	Z	Deselect
L	H	Z	Valid	Read
L	L	Valid	Z	Write

NOTES 1. Logic Level Definitions, L = Low Level, H = High Level, Z = High Impedance, X = Irrelevant.

TIMING WAVEFORMS

READ CYCLE 1

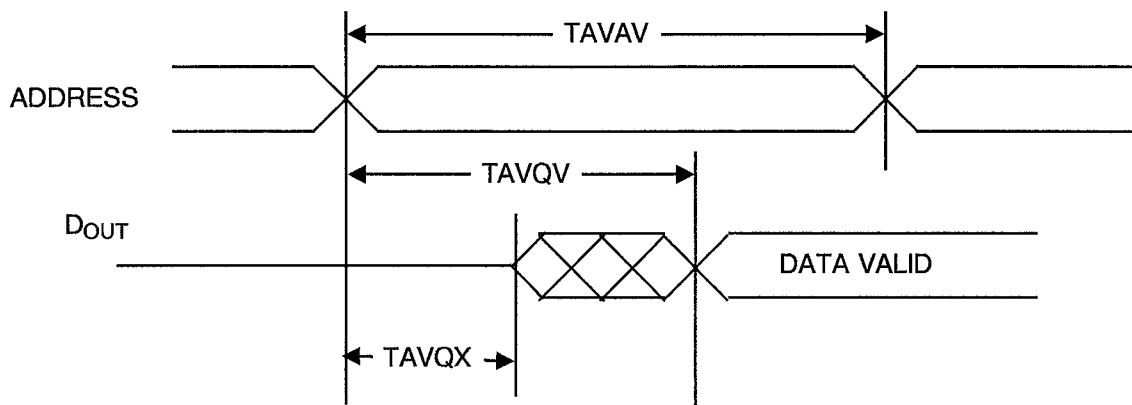

NOTES 1. \overline{W} is High throughout Read Cycle.
 2. Device is continuously selected.

READ CYCLE 2

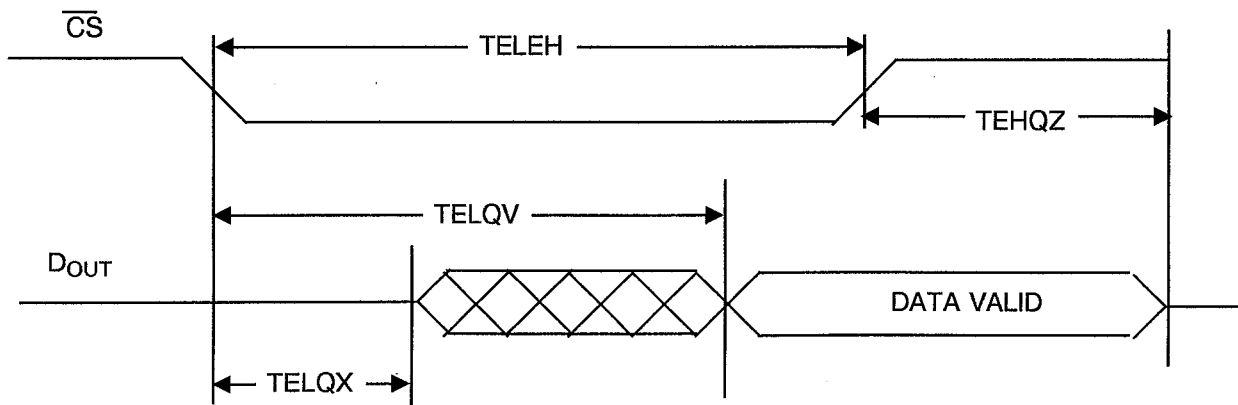

NOTES 1. \overline{W} is High throughout Read Cycle.
 2. Address valid prior to or coincident with \overline{CS} transition low.



WRITE CYCLE 1 (\overline{W} CONTROLLED)

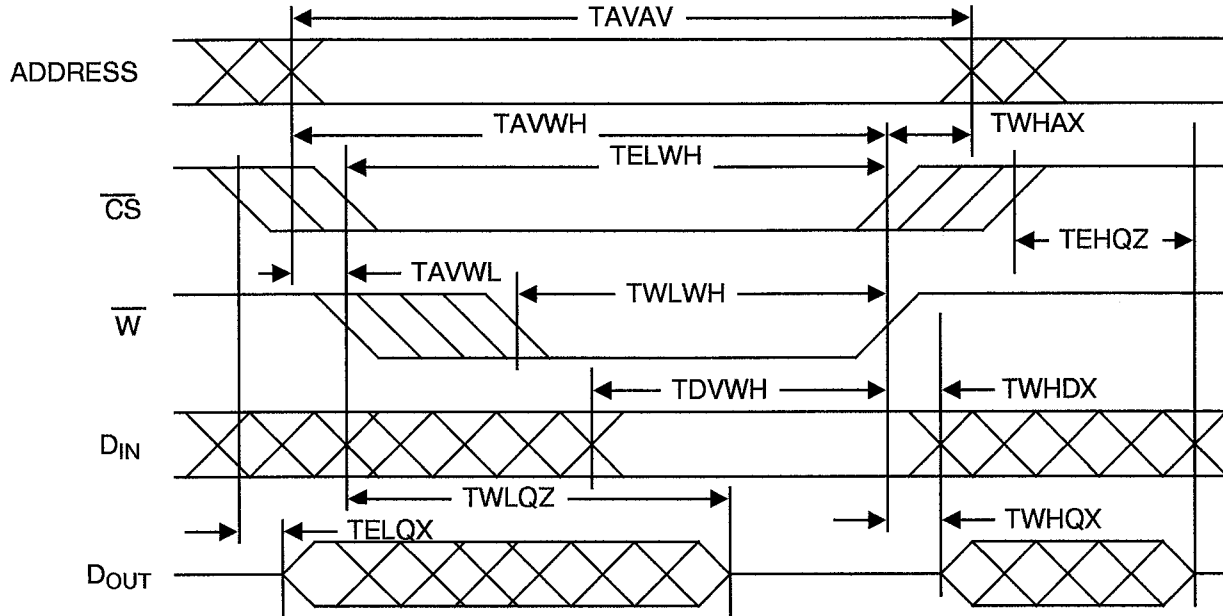

NOTES

1. The internal write time of the memory is defined by the overlap of \overline{CS} Low and \overline{W} Low. Both signals must be Low to initiate a write and either signal can terminate a write by going High. The data input setup and hold timing should be referenced to the rising edge of the signal that terminates the write.

WRITE CYCLE 2 (\overline{CS} CONTROLLED)

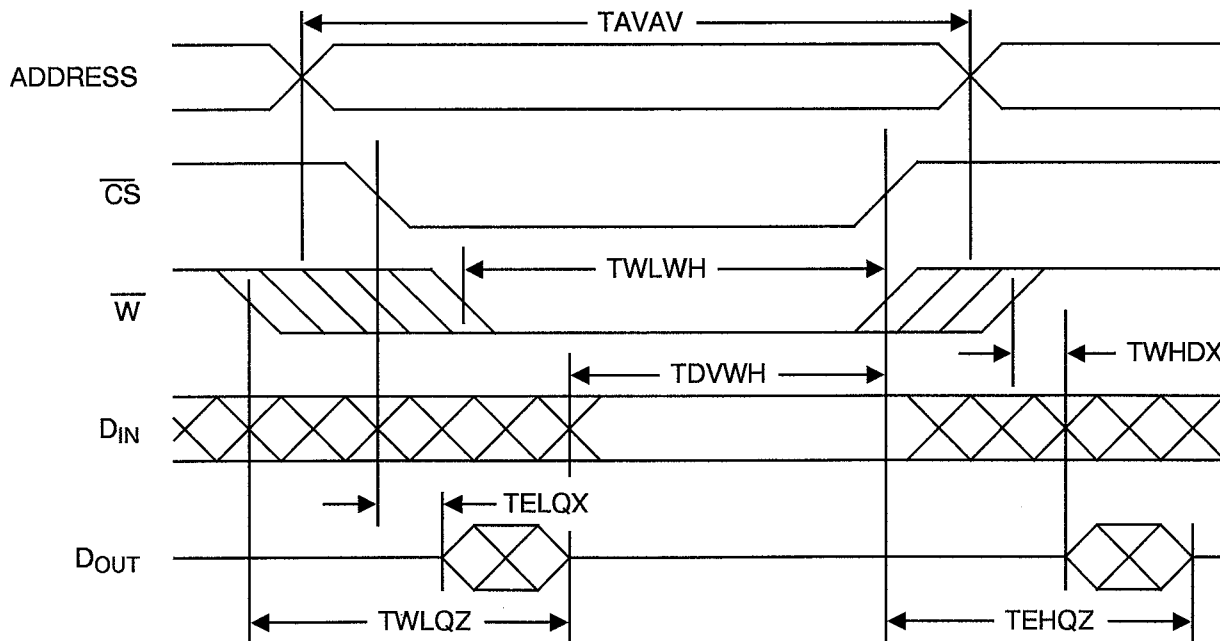

NOTES

1. The internal write time of the memory is defined by the overlap of \overline{CS} Low and \overline{W} Low. Both signals must be Low to initiate a write and either signal can terminate a write by going High. The data input setup and hold timing should be referenced to the rising edge of the signal that terminates the write.

FIGURE 3(c) - CIRCUIT SCHEMATIC

Not applicable

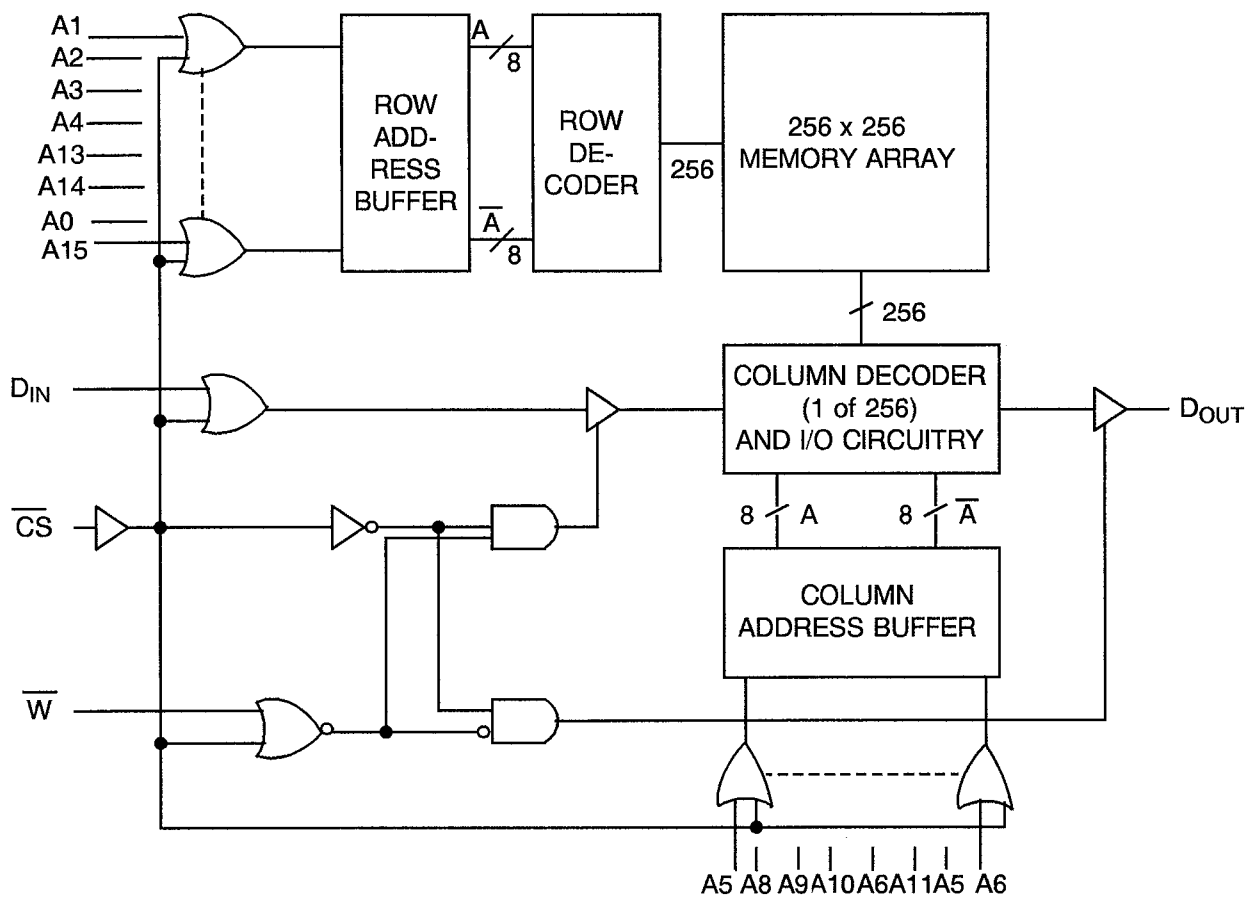
FIGURE 3(d) - FUNCTIONAL DIAGRAM

FIGURE 3(e) - INPUT PROTECTION NETWORK

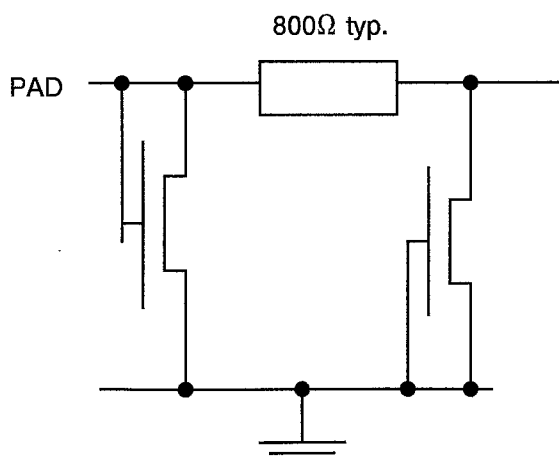
EQUIVALENT OF EACH INPUT



**2. APPLICABLE DOCUMENTS**

The following documents form part of this specification and shall be read in conjunction with it:-

- (a) ESA/SCC Generic Specification No. 9000 for Integrated Circuits.
- (b) MIL-STD-883, Test Methods and Procedures for Micro-electronics.

3. TERMS, DEFINITIONS, ABBREVIATIONS, SYMBOLS AND UNITS

For the purpose of this specification, the terms, definitions, abbreviations, symbols and units specified in ESA/SCC Basic Specification No. 21300 shall apply. In addition, the following abbreviations are used:

- V_{IC} = Input Clamp Voltage.
- I_{OZL} = Output Leakage Current Third State (Low Level Applied)
- I_{OZH} = Output Leakage Current Third State (High Level Applied)
- C_{IN} = Input Capacitance.
- C_{OUT} = Output Capacitance
- TAVAV = Cycle Time.
- TAVQV = \overline{A} Address Access Time
- TELQV = \overline{CS} CS Access Time.
- TELQX = \overline{CS} Low Output Enable Time.
- TELEH = \overline{CS} Low to \overline{CS} High Time.
- TEHQZ = \overline{CS} High Output Disable Time.
- TAVQX = Output Change from Address Change.
- TELWH = \overline{CS} Low to End of Write.
- TAVWL = \overline{A} Address Set-up Time.
- TWLWH = \overline{W} Low Pulse Width.
- TWHAX = Address Hold from Write End.
- TWLQZ = \overline{W} Low Output Disable Time.
- TDVWH = Data Set-up Time.
- TWHDX = Data Hold Time.
- TWHQX = \overline{W} High Output Enable Time
- TAVWH = Address Valid to Write End.
- t_r = Recovery Time from Data Retention.

4. REQUIREMENTS**4.1 GENERAL**

The complete requirements for procurement of the integrated circuits specified herein are stated in this specification and ESA/SCC Generic Specification No. 9000 for Integrated Circuits. Deviations from the Generic Specification, applicable to this specification only, are listed in Para. 4.2.

Deviations from the applicable Generic Specification and this Detail Specification, formally agreed with specific Manufacturers on the basis that the alternative requirements are equivalent to the ESA/SCC requirements and do not affect the components' reliability, are listed in the appendices attached to this specification.



4.2 DEVIATIONS FROM GENERIC SPECIFICATION

4.2.1 Deviations from Special In-process Controls

- (a) Para. 5.2.2, Total Dose Irradiation Testing: Shall be performed during qualification and extension of qualification.
- (b) Para. 5.2.2, Total Dose Irradiation Testing: Shall be performed during procurement on a lot acceptance basis at the total dose irradiation level specified in the Purchase Order.

4.2.2 Deviations from Final Production Tests (Chart II)

- (a) Para. 9.9.3, Electrical Measurements may be performed at high temperature.

4.2.3 Deviations from Burn-in Tests (Chart III)

- (a) Para. 7.1.1(a), "High Temperature Reverse Bias" tests and subsequent electrical measurements related to this test shall be omitted.

4.2.4 Deviations from Qualification Tests (Chart IV)

- (a) The electrical measurements referenced in Para. 9.9.4 shall be performed as stated in Table 2 of this specification.

4.2.5 Deviations from Lot Acceptance Tests (Chart V)

- (a) The electrical measurements referenced in Para. 9.9.4 shall be performed as stated in Table 2 of this specification.

4.3 MECHANICAL REQUIREMENTS

4.3.1 Dimension Check

The dimensions of the integrated circuits specified herein shall be checked. They shall conform to those shown in Figure 2.

4.3.2 Weight

The maximum weight of the integrated circuits specified herein shall be 3.0 grammes for Variants 1, 4, 7 and 10, 4.0 grammes for Variants 2, 5, 8 and 11 and 0.5 grammes for Variants 3, 6, 9 and 12.

4.4 MATERIALS AND FINISHES

The materials shall be as specified herein. Where a definite material is not specified, a material which will enable the integrated circuits specified herein to meet the performance requirements of this specification shall be used. Acceptance or approval of any constituent material does not guarantee acceptance of the finished product.

4.4.1 Case

The case shall be hermetically sealed and have a ceramic body and the lids shall be welded, brazed, preform-soldered or glass-frit-sealed.

4.4.2 Lead Material and Finish

For dual-in-line packages, the material shall be Type 'D' with Type '7' finish or Type 'G' with Type '3' finish in accordance with the requirements of ESA/SCC Basic Specification No. 23500. For chip carrier packages the finish shall be Type '7' in accordance with the requirements of ESA/SCC Basic Specification No. 23500. (See Table 1(a) for Type Variants).

4.5 MARKING

4.5.1 General

The marking of all components delivered to this specification shall be in accordance with the requirements of ESA/SCC Basic Specification No. 21700. Each component shall be marked in respect of:-

- (a) Lead Identification.
- (b) The SCC Component Number.
- (c) Traceability Information.

4.5.2 Lead Identification

For dual-in-line packages, an index shall be located at the top of the package in the position defined in Note 1 to Figure 2 or, alternatively, a tab may be used to identify Pin No. 1. The pin numbering must be read with the index or tab on the left-hand side. For chip carrier packages, the index shall be as defined by Figure 2(c).

4.5.3 The SCC Component Number

Each component shall bear the SCC Component Number which shall be constituted and marked as follows:

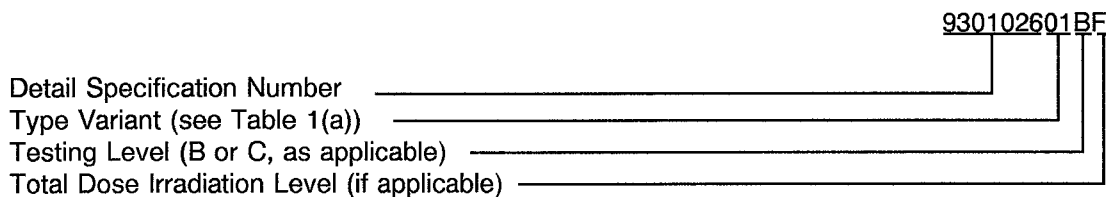

The Total Dose Irradiation Level designation shall be added for those devices for which a sample has been successfully tested to the level in question. For these devices, a code letter shall be added in accordance with the requirements of ESA/SCC Basic Specification No. 22900.

4.5.4 Traceability Information

Each component shall be marked in respect of traceability information in accordance with the requirements of ESA/SCC Basic Specification No. 21700.

4.6 ELECTRICAL MEASUREMENTS

4.6.1 Electrical Measurements at Room Temperature

The parameters to be measured in respect of electrical characteristics are scheduled in Table 2. Unless otherwise specified, the measurements shall be performed at $T_{amb} = +22 \pm 3$ °C.

4.6.2 Electrical Measurements at High and Low Temperatures

The parameters to be measured at high and low temperatures are scheduled in Table 3. The measurements shall be performed at $T_{amb} = +125(+0-5)$ °C and $-55(+5-0)$ °C respectively.

4.6.3 Circuits for Electrical Measurements

Circuits and test sequences for use in performing electrical measurements listed in Tables 2 and 3 of this specification are shown in Figure 4.

	ESA/SCC Detail Specification No. 9301/026		PAGE 19 ISSUE 1
---	--	--	--------------------

4.7 BURN-IN TESTS

4.7.1 Parameter Drift Values

The parameter drift values applicable to Power Burn-in are specified in Table 4 of this specification. Unless otherwise stated, measurements shall be performed at $T_{amb} = +22 \pm 3$ °C. The parameter drift values (Δ), applicable to the parameters scheduled, shall not be exceeded. In addition to these drift value requirements, the appropriate limit value specified for a given parameter in Table 2 shall not be exceeded.

4.7.2 Conditions for Power Burn-in

The requirements for Power Burn-in are specified in Section 7 of ESA/SCC Generic Specification No. 9000. The conditions for Power Burn-in shall be as specified in Table 5 of this specification.

4.7.3 Electrical Circuits for Power Burn-in

Circuits for use in performing the Power Burn-in tests are shown in Figure 5 of this specification.



TABLE 2 - ELECTRICAL MEASUREMENTS AT ROOM TEMPERATURE - d.c. PARAMETERS

NO.	CHARACTERISTICS	SYMBOL	TEST METHOD MIL-STD 883	TEST FIG.	TEST CONDITIONS (PINS UNDER TEST)	LIMITS		UNIT
						MIN	MAX	
1 to 6	Functional Test 1 (Nominal Inputs)	-	3014	3(b)	Verify Truth Table. For Input Conditions and Test Patterns, see Note 1	-	-	-
7 to 12	Functional Test 2 (Worst Case Inputs)	-	3014	3(b)	Verify Truth Table. For Input Conditions and Test Patterns, see Note 1	-	-	-
13 to 16	Functional Test 3 (Worst Case Outputs)	-	3014	3(b)	Verify Truth Table. For Input Conditions and Test Patterns, see Note 1	-	-	-
17 to 35	Input Current Low Level	I_{IL}	3009	4(a)	V_{IN} (Under Test) = 0V V_{IN} (Remaining Inputs) = 5.5V $V_{DD} = 5.5V, V_{SS} = 0V$ (Pins 1-2-3-4-5-6-7-8-10-12-13-14-15-16-17-18-19-20-21)	-1.0	+1.0	μA
36 to 54	Input Current High Level	I_{IH}	3010	4(b)	V_{IN} (Under Test) = 5.5V V_{IN} (Remaining Inputs) = 0V $V_{DD} = 5.5V, V_{SS} = 0V$ (Pins 1-2-3-4-5-6-7-8-10-12-13-14-15-16-17-18-19-20-21)	-1.0	+1.0	μA
55	Output Voltage Low Level	V_{OL}	3007	4(c)	$V_{IL} = 0V, V_{IH} = 3.0V$ $I_{OL} = 4.0mA, V_{IN(\overline{W})} = 4.5V$ $V_{IN(\overline{CS})} = 0V,$ $V_{DD} = 4.5V, V_{SS} = 0V$ Note 2 (Pin 9)	-	0.4	V
56	Output Voltage High Level	V_{OH}	3006	4(d)	$V_{IL} = 0V, V_{IH} = 3.0V$ $I_{OH} = -1.0mA, V_{IN(\overline{W})} = 4.5V$ $V_{IN(\overline{CS})} = 0V$ $V_{DD} = 4.5V, V_{SS} = 0V$ Note 3 (Pin 9)	2.4	-	V

NOTES: See Page 26.



TABLE 2 - ELECTRICAL MEASUREMENTS AT ROOM TEMPERATURE - d.c. PARAMETERS (CONTINUED)

NO.	CHARACTERISTICS	SYMBOL	TEST METHOD MIL-STD 883	TEST FIG.	TEST CONDITIONS (PINS UNDER TEST)	LIMITS		UNIT
						MIN	MAX	
57 to 75	Input Clamp Voltage (to V _{SS})	V _{IC}	-	4(e)	I _{IN} (Under Test) = -100μA V _{DD} = Open, V _{SS} = 0V All Other Pins Open (Pins 1-2-3-4-5-6-7-8-10-12-13-14-15-16-17-18-19-20-21)	-0.2	-2.0	V
76	Output Leakage Current Third State (Low Level Applied)	I _{OZL}	-	4(f)	V _{IN} (\overline{CS})(\overline{W}) = 0V V _{OUT} = 0V V _{DD} = 5.5V, V _{SS} = 0V (Pin 9)	-1.0	+1.0	μA
77	Output Leakage Current Third State (High Level Applied)	I _{OZH}	-	4(f)	V _{IN} (\overline{CS})(\overline{W}) = 0V V _{OUT} = 5.0V V _{DD} = 5.5V, V _{SS} = 0V (Pin 9)	-1.0	+1.0	μA
78	Supply Current (Operating)	I _{DDop}	3005	4(g)	V _{IN} (\overline{CS}) = 0.8V V _{IN} (Remaining Inputs) = 0V to 3.0V Pattern: ICCACT I _{OUT} = 0mA V _{DD} = 5.5V, V _{SS} = 0V (Pin 22) Variants 1-2-3: f = 9.0MHz Variants 4-5-6: f = 11MHz Variants 7-8-9: f = 11MHz Variants 10-11-12: f = 9.0MHz	-	75 75 100 100	mA
79	Supply Current 1 (Standby)	I _{DDSB1}	3005	4(g)	V _{IN} (\overline{CS}) = 2.2V V _{IN} (Remaining Inputs) = 0.8V I _{OUT} = 0mA V _{DD} = 5.5V, V _{SS} = 0V (Pin 22) Variants 1-2-3 Variants 4-5-6 Variants 7-8-9 Variants 10-11-12	-	15 15 20 20	mA
80	Supply Current 2 (Standby)	I _{DDSB2}	3005	4(g)	V _{IN} (\overline{CS}) = V _{DD} -0.3V V _{IN} (Remaining Inputs) = V _{DD} -0.3V to -0.3V I _{OUT} = 0mA V _{DD} = 5.5V, V _{SS} = 0V (Pin 22) Note 4 Variants 1-2-3 Variants 4-5-6 Variants 7-8-9 Variants 10-11-12	-	50 50 500 500	μA

NOTES: See Page 26.

TABLE 2 - ELECTRICAL MEASUREMENTS AT ROOM TEMPERATURE - d.c. PARAMETERS (CONTINUED)

NO.	CHARACTERISTICS	SYMBOL	TEST METHOD MIL-STD 883	TEST FIG.	TEST CONDITIONS (PINS UNDER TEST)	LIMITS		UNIT
						MIN	MAX	
81	Data Retention Current	I _{DDDR}	3005	4(h)	$V_{IL} = 0V, V_{IH} = 2.0V$ $V_{IN(\overline{CS})} = 2.0V$ $V_{DD} = 2.0V, V_{SS} = 0V$ Note 4 (Pin 22) Variants 1-2-3 Variants 4-5-6 Variants 7-8-9 Variants 10-11-12	-	20	μA
82	Data Retention	DR	-	-	$V_{IL} = 0V, V_{IH} = 3.0V$ $V_{IN(\overline{CS})} = 4.5V$ $V_{DD} = 4.5V, V_{SS} = 0V$ Note 5 (Pin 9)	-	-	-

NOTES: See Page 26.

TABLE 2 - ELECTRICAL MEASUREMENTS AT ROOM TEMPERATURE - a.c. PARAMETERS

NO.	CHARACTERISTICS	SYMBOL	TEST METHOD MIL-STD 883	TEST FIG.	TEST CONDITIONS (PINS UNDER TEST)	LIMITS		UNIT
						MIN	MAX	
83 to 101	Input Capacitance	C _{IN}	3012	4(i)	V _{IN} (Not Under Test) = 0V V _{DD} = V _{SS} = 0V Note 6 (Pins 1-2-3-4-5-6-7-8-10-12-13-14-15-16-17-18-19-20-21)	-	5.0	pF
102	Output Capacitance	C _{OUT}	3012	4(j)	V _{IN} (Not Under Test) = 0V V _{DD} = V _{SS} = 0V Note 6 (Pin 9)	-	7.0	pF
103 to 106	Functional Test 4 (Nominal Inputs)	-	3014	3(b)	Verify Truth Table. For Input and Output Conditions, see Note 7 V _{SS} = 0V	-	-	-
107 to 108	Access Time (Address)	TAVQV	-	4(k)	V _{DD} = 4.5V and 5.5V V _{SS} = 0V Notes 7 and 9 Variants 1-2-3 Variants 4-5-6 Variants 7-8-9 Variants 10-11-12	-	55 45 55 45	ns
109 to 110	Access Time (Chip Select)	TELQV	-	4(k)	V _{DD} = 4.5V and 5.5V V _{SS} = 0V Notes 7 and 9 Variants 1-2-3 Variants 4-5-6 Variants 7-8-9 Variants 10-11-12	-	55 45 55 45	ns
111 to 112	Write Pulse Width (W Low)	TWLWH	-	4(k)	V _{DD} = 4.5V and 5.5V V _{SS} = 0V Notes 7 and 10 Variants 1-2-3 Variants 4-5-6 Variants 7-8-9 Variants 10-11-12	-	50 40 50 40	ns
113 to 114	Data Set-up Time	TDVWH	-	4(k)	V _{DD} = 4.5V and 5.5V V _{SS} = 0V Notes 7 and 9	-	30	ns

NOTES: See Page 26.



TABLE 2 - ELECTRICAL MEASUREMENTS AT ROOM TEMPERATURE - a.c. PARAMETERS (CONTINUED)

NO.	CHARACTERISTICS	SYMBOL	TEST METHOD MIL-STD 883	TEST FIG.	TEST CONDITIONS (PINS UNDER TEST)	LIMITS		UNIT
						MIN	MAX	
115 to 116	Data Hold Time	TWHDX	-	4(k)	V _{DD} = 4.5V and 5.5V V _{SS} = 0V Notes 7 and 9	3.0	-	ns
117 to 118	Read/Write Cycle Time	TAVAV	-	4(k)	V _{DD} = 4.5V and 5.5V V _{SS} = 0V Notes 7 and 10 Variants 1-2-3 Variants 4-5-6 Variants 7-8-9 Variants 10-11-12	55 45 55 45	- - - -	ns
119 to 120	Output Change from Address Cycle	TAVQX	-	4(k)	V _{DD} = 4.5V and 5.5V V _{SS} = 0V Notes 7 and 10	3.0	-	ns
121 to 122	CS Low to End of Write	TELWH	-	4(k)	V _{DD} = 4.5V and 5.5V V _{SS} = 0V Notes 7 and 10 Variants 1-2-3 Variants 4-5-6 Variants 7-8-9 Variants 10-11-12	55 45 55 45	- - - -	ns
123 to 124	Address Set-up Time	TAVWL	-	4(k)	V _{DD} = 4.5V and 5.5V V _{SS} = 0V Notes 7 and 10	0	-	ns
125 to 126	Address Valid to End of Write	TAVWH	-	4(k)	V _{DD} = 4.5V and 5.5V V _{SS} = 0V Notes 7 and 10 Variants 1-2-3 Variants 4-5-6 Variants 7-8-9 Variants 10-11-12	55 45 55 45	- - - -	ns
127 to 128	Address Hold from Write End	TWHAX	-	4(k)	V _{DD} = 4.5V and 5.5V V _{SS} = 0V Notes 7 and 10	5.0	-	ns
129 to 130	Output Enable Time (CS Low)	TELQX	-	4(k)	V _{DD} = 4.5V and 5.5V V _{SS} = 0V Notes 6 and 7	5.0	-	ns

NOTES: See Page 26.

TABLE 2 - ELECTRICAL MEASUREMENTS AT ROOM TEMPERATURE - a.c. PARAMETERS (CONTINUED)

NO.	CHARACTERISTICS	SYMBOL	TEST METHOD MIL-STD 883	TEST FIG.	TEST CONDITIONS (PINS UNDER TEST)	LIMITS		UNIT
						MIN	MAX	
131 to 132	Output Disable Time (CS High)	TEHQZ	-	4(k)	V _{DD} = 4.5V and 5.5V V _{SS} = 0V Notes 6 and 7 Variants 1-2-3 Variants 4-5-6 Variants 7-8-9 Variants 10-11-12	-	55 45 55 45	ns
133 to 134	Output Disable Time (W Low)	TWLQZ	-	4(k)	V _{DD} = 4.5V and 5.5V V _{SS} = 0V Notes 6 and 7 Variants 1-2-3 Variants 4-5-6 Variants 7-8-9 Variants 10-11-12	50 40 50 40	- - - -	ns
135 to 136	Output Enable Time (W High)	TWHQX	-	4(k)	V _{DD} = 4.5V and 5.5V V _{SS} = 0V Notes 6 and 7	0	-	ns

NOTES: See Page 26.

TABLE 2 - ELECTRICAL MEASUREMENTS AT ROOM TEMPERATURE (CONTINUED)

NOTES

1. Functional test go-no-go with the following test sequences:-

FUNCTIONAL TEST 1

Pattern	Timing	V _{DD}	V _{SS}	V _{IL}	V _{IH}	I _{OL}	I _{OH}	V _{OUT} (COMP)
MARCH, COMARCH	300ns	4.5V and 5.5V	0V	0V	3.0V	0mA	0mA	1.5V
CHECKERBOARD	300ns	4.5V and 5.5V	0V	0V	3.0V	0mA	0mA	1.5V

FUNCTIONAL TEST 2

Pattern	Timing	V _{DD}	V _{SS}	V _{IL} CK's	V _{IH} CK's	V _{IL} DATA	V _{IH} DATA	V _{IL} ADD	V _{IH} ADD	I _{OL}	I _{OH}	V _{OUT} (COMP)
MARCH	300ns	6.5V	0V	0V	5.5V	0V	5.5V	0V	5.5V	0mA	0mA	1.5V
MARCH	300ns	4.5V	0V	0V	3.0V	0V	3.0V	0V	3.0V	0mA	0mA	1.5V
MARCH	2350ns	5.5V	0V	0V	2.2V	0V	2.2V	0V	5.5V	0mA	0mA	1.5V
MARCH	2350ns	5.5V	0V	0V	5.5V	0V	5.5V	0V	2.2V	0mA	0mA	1.5V
MARCH	2350ns	4.5V	0V	0.8V	3.0V	0.8V	3.0V	0V	2.2V	0mA	0mA	1.5V
MARCH	2350ns	4.5V	0V	0V	4.5V	0V	4.5V	0.8V	3.0V	0mA	0mA	1.5V

FUNCTIONAL TEST 3

Pattern	Timing	V _{DD}	V _{SS}	V _{IL}	V _{IH}	I _{OL}	I _{OH}	V _{OUT} (COMP)
MARCH	2350ns	5.5V	0V	0V	3.0V	4.0mA	-1.0mA	2.0V
MARCH	2350ns	4.5V	0V	0V	3.0V	4.0mA	-1.0mA	2.0V
CHIP DESELECT	300ns	4.5V	0V	0V	3.0V	0.5mA	-0.5mA	1.5V
LONG CHIP SELECT	3000ns	4.5V	0V	0V	3.0V	0.5mA	-0.5mA	1.5V

2. Select Address Inputs to produce low level output at the pin under test in accordance with Figure 3(b).
3. Select Address Inputs to produce high level output at the pin under test in accordance with Figure 3(b).
4. Measurement is performed with the memory loaded with a background of zeros and then with a background of ones, for all inputs high and then low. Only worst case is recorded.
5. Data Retention Procedure:-
 - (a) Write memory with Checkerboard pattern with Timing = 300ns at the conditions given.
 - (b) Power Down to V_{DD} = 1.6 ± 0V for 250ms. (This is a test condition only. Memory retention cannot be guaranteed if V_{DD} is reduced below 2.0V).
 - (c) Restore to original conditions given, read Memory and compare with original pattern.
 - (d) Repeat the procedure with Checkerboard pattern with timing = 300ns at the conditions given.
 - (e) For Variants 04, 05, 06, 10, 11 and 12: t_r = 45ns, for Variants 01, 02, 03, 07, 08 and 09: t_r = 55ns.

TABLE 2 - ELECTRICAL MEASUREMENTS AT ROOM TEMPERATURE (CONTINUED)

NOTES

6. Guaranteed but not tested. Characterised at initial design and after major process changes.

7. **FUNCTIONAL TEST 4**

Pattern	Timing Variants 4-5-6- 10-11-12	Timing Variants 1-2-3- 7-8-9	V _{DD}	V _{IL}	V _{IH}	V _{OUT (COMP)}
MARCH/ <u>COMARCH</u>	115ns	140ns	4.5V	0V	3.0V	1.5V
MARCH (<u>CS</u> LOW)	115ns	140ns	4.5V	0V	3.0V	1.5V
COMARCH (<u>CS</u> LOW)	115ns	140ns	4.5V	0V	3.0V	1.5V
MARCH/ <u>COMARCH</u>	125ns	150ns	5.5V	0V	3.0V	1.5V
MARCH (<u>CS</u> LOW)	125ns	150ns	5.5V	0V	3.0V	1.5V
COMARCH (<u>CS</u> LOW)	125ns	150ns	5.5V	0V	3.0V	1.5V

Output Load = 1 TTL Gate equivalent + C_L ≤ 100pF.

- 8. Tested go-no-go using March, Comarch and Walkcol patterns.
- 9. Parameters measured using March pattern during Functional Test 4.
- 10. Parameters tested go-no-go during Functional Test 4.

TABLE 3 - ELECTRICAL MEASUREMENTS AT HIGH AND LOW TEMPERATURES - d.c. PARAMETERS

NO.	CHARACTERISTICS	SYMBOL	TEST METHOD MIL-STD 883	TEST FIG.	TEST CONDITIONS (PINS UNDER TEST)	LIMITS		UNIT
						MIN	MAX	
1 to 6	Functional Test 1 (Nominal Inputs)	-	3014	3(b)	Verify Truth Table. For Input Conditions and Test Patterns, see Note 1	-	-	-
7 to 12	Functional Test 2 (Worst Case Inputs)	-	3014	3(b)	Verify Truth Table. For Input Conditions and Test Patterns, see Note 1	-	-	-
13 to 16	Functional Test 3 (Worst Case Outputs)	-	3014	3(b)	Verify Truth Table. For Input Conditions and Test Patterns, see Note 1	-	-	-
17 to 35	Input Current Low Level	I_{IL}	3009	4(a)	V_{IN} (Under Test) = 0V V_{IN} (Remaining Inputs) = 5.5V $V_{DD} = 5.5V, V_{SS} = 0V$ (Pins 1-2-3-4-5-6-7-8-10-12-13-14-15-16-17-18-19-20-21)	-1.0	+1.0	μA
36 to 54	Input Current High Level	I_{IH}	3010	4(b)	V_{IN} (Under Test) = 5.5V V_{IN} (Remaining Inputs) = 0V $V_{DD} = 5.5V, V_{SS} = 0V$ (Pins 1-2-3-4-5-6-7-8-10-12-13-14-15-16-17-18-19-20-21)	-1.0	+1.0	μA
55	Output Voltage Low Level	V_{OL}	3007	4(c)	$V_{IL} = 0V, V_{IH} = 3.0V$ $I_{OL} = 4.0mA, V_{IN(\overline{W})} = 4.5V$ $V_{IN(\overline{CS})} = 0V,$ $V_{DD} = 4.5V, V_{SS} = 0V$ Note 2 (Pin 9)	-	0.4	V
56	Output Voltage High Level	V_{OH}	3006	4(d)	$V_{IL} = 0V, V_{IH} = 3.0V$ $I_{OH} = -1.0mA, V_{IN(\overline{W})} = 4.5V$ $V_{IN(\overline{CS})} = 0V$ $V_{DD} = 4.5V, V_{SS} = 0V$ Note 3 (Pin 9)	2.4	-	V

NOTES: See Page 26.



**TABLE 3 - ELECTRICAL MEASUREMENTS AT HIGH AND LOW TEMPERATURES - d.c. PARAMETERS
(CONTINUED)**

NO.	CHARACTERISTICS	SYMBOL	TEST METHOD MIL-STD 883	TEST FIG.	TEST CONDITIONS (PINS UNDER TEST)	LIMITS		UNIT
						MIN	MAX	
57 to 75	Input Clamp Voltage (to V _{SS})	V _{IC}	-	4(e)	I _{IN} (Under Test) = -100μA V _{DD} = Open, V _{SS} = 0V All Other Pins Open (Pins 1-2-3-4-5-6-7-8-10-12-13-14-15-16-17-18-19-20-21)	-0.2	-2.0	V
76	Output Leakage Current Third State (Low Level Applied)	I _{OZL}	-	4(f)	V _{IN} (\overline{CS})(\overline{W}) = 0V V _{OUT} = 0V V _{DD} = 5.5V, V _{SS} = 0V (Pin 9)	-1.0	+1.0	μA
77	Output Leakage Current Third State (High Level Applied)	I _{OZH}	-	4(f)	V _{IN} (\overline{CS})(\overline{W}) = 0V V _{OUT} = 5.0V V _{DD} = 5.5V, V _{SS} = 0V (Pin 9)	-1.0	+1.0	μA
78	Supply Current (Operating)	I _{DDop}	3005	4(g)	V _{IN} (\overline{CS}) = 0.8V V _{IN} (Remaining Inputs) = 0V to 3.0V Pattern: ICCACT I _{OUT} = 0mA V _{DD} = 5.5V, V _{SS} = 0V (Pin 22) Variants 1-2-3: f = 9.0MHz Variants 4-5-6: f = 11MHz Variants 7-8-9: f = 11MHz Variants 10-11-12: f = 9.0MHz	-	75 75 100 100	mA
79	Supply Current 1 (Standby)	I _{DDSB1}	3005	4(g)	V _{IN} (\overline{CS}) = 2.2V V _{IN} (Remaining Inputs) = 0.8V I _{OUT} = 0mA V _{DD} = 5.5V, V _{SS} = 0V (Pin 22) Variants 1-2-3 Variants 4-5-6 Variants 7-8-9 Variants 10-11-12	-	15 15 20 20	mA
80	Supply Current 2 (Standby)	I _{DDSB2}	3005	4(g)	V _{IN} (\overline{CS}) = V _{DD} -0.3V V _{IN} (Remaining Inputs) = V _{DD} -0.3V to -0.3V I _{OUT} = 0mA V _{DD} = 5.5V, V _{SS} = 0V (Pin 22) Note 4 Variants 1-2-3 Variants 4-5-6 Variants 7-8-9 Variants 10-11-12	-	50 50 500 500	μA

NOTES: See Page 26.

**TABLE 3 - ELECTRICAL MEASUREMENTS AT HIGH AND LOW TEMPERATURES - d.c. PARAMETERS
(CONTINUED)**

NO.	CHARACTERISTICS	SYMBOL	TEST METHOD MIL-STD 883	TEST FIG.	TEST CONDITIONS (PINS UNDER TEST)	LIMITS		UNIT
						MIN	MAX	
81	Data Retention Current	I _{DDDR}	3005	4(h)	V _{IL} = 0V, V _{IH} = 2.0V V _{IN(CS)} = 2.0V V _{DD} = 2.0V, V _{SS} = 0V Note 4 (Pin 22) Variants 1-2-3 Variants 4-5-6 Variants 7-8-9 Variants 10-11-12	-	20	μA
					-	20		
					-	200		
					-	200		
82	Data Retention	DR	-	-	V _{IL} = 0V, V _{IH} = 3.0V V _{IN(CS)} = 4.5V V _{DD} = 4.5V, V _{SS} = 0V Note 5 (Pin 9)	-	-	-

NOTES: See Page 26.

TABLE 3 - ELECTRICAL MEASUREMENTS AT HIGH AND LOW TEMPERATURES - a.c. PARAMETERS

NO.	CHARACTERISTICS	SYMBOL	TEST METHOD MIL-STD 883	TEST FIG.	TEST CONDITIONS (PINS UNDER TEST)	LIMITS		UNIT
						MIN	MAX	
83 to 101	Input Capacitance	C _{IN}	3012	4(i)	V _{IN} (Not Under Test) = 0V V _{DD} = V _{SS} = 0V Note 6 (Pins 1-2-3-4-5-6-7-8-10-12-13-14-15-16-17-18-19-20-21)	-	5.0	pF
102	Output Capacitance	C _{OUT}	3012	4(j)	V _{IN} (Not Under Test) = 0V V _{DD} = V _{SS} = 0V Note 6 (Pin 9)	-	7.0	pF
103 to 106	Functional Test 4 (Nominal Inputs)	-	3014	3(b)	Verify Truth Table. For Input and Output Conditions, see Note 7 V _{SS} = 0V	-	-	-
107 to 108	Access Time (Address)	TAVQV	-	4(k)	V _{DD} = 4.5V and 5.5V V _{SS} = 0V Notes 7 and 9 Variants 1-2-3 Variants 4-5-6 Variants 7-8-9 Variants 10-11-12	-	55 45 55 45	ns
109 to 110	Access Time (Chip Select)	TELQV	-	4(k)	V _{DD} = 4.5V and 5.5V V _{SS} = 0V Notes 7 and 9 Variants 1-2-3 Variants 4-5-6 Variants 7-8-9 Variants 10-11-12	-	55 45 55 45	ns
111 to 112	Write Pulse Width (W Low)	TWLWH	-	4(k)	V _{DD} = 4.5V and 5.5V V _{SS} = 0V Notes 7 and 10 Variants 1-2-3 Variants 4-5-6 Variants 7-8-9 Variants 10-11-12	-	50 40 50 40	ns
113 to 114	Data Set-up Time	TDVWH	-	4(k)	V _{DD} = 4.5V and 5.5V V _{SS} = 0V Notes 7 and 9	-	30	ns

NOTES: See Page 26.

**TABLE 3 - ELECTRICAL MEASUREMENTS AT HIGH AND LOW TEMPERATURES - a.c. PARAMETERS
(CONTINUED)**

NO.	CHARACTERISTICS	SYMBOL	TEST METHOD MIL-STD 883	TEST FIG.	TEST CONDITIONS (PINS UNDER TEST)	LIMITS		UNIT
						MIN	MAX	
115 to 116	Data Hold Time	TWHDX	-	4(k)	V _{DD} = 4.5V and 5.5V V _{SS} = 0V Notes 7 and 9	3.0	-	ns
117 to 118	Read/Write Cycle Time	TAVAV	-	4(k)	V _{DD} = 4.5V and 5.5V V _{SS} = 0V Notes 7 and 10 Variants 1-2-3 Variants 4-5-6 Variants 7-8-9 Variants 10-11-12	55 45 55 45	- - - -	ns
119 to 120	Output Change from Address Cycle	TAVQX	-	4(k)	V _{DD} = 4.5V and 5.5V V _{SS} = 0V Notes 7 and 10	3.0	-	ns
121 to 122	CS Low to End of Write	TELWH	-	4(k)	V _{DD} = 4.5V and 5.5V V _{SS} = 0V Notes 7 and 10 Variants 1-2-3 Variants 4-5-6 Variants 7-8-9 Variants 10-11-12	55 45 55 45	- - - -	ns
123 to 124	Address Set-up Time	TAVWL	-	4(k)	V _{DD} = 4.5V and 5.5V V _{SS} = 0V Notes 7 and 10	0	-	ns
125 to 126	Address Valid to End of Write	TAVWH	-	4(k)	V _{DD} = 4.5V and 5.5V V _{SS} = 0V Notes 7 and 10 Variants 1-2-3 Variants 4-5-6 Variants 7-8-9 Variants 10-11-12	55 45 55 45	- - - -	ns
127 to 128	Address Hold from Write End	TWHAX	-	4(k)	V _{DD} = 4.5V and 5.5V V _{SS} = 0V Notes 7 and 10	5.0	-	ns
129 to 130	Output Enable Time (CS Low)	TELQX	-	4(k)	V _{DD} = 4.5V and 5.5V V _{SS} = 0V Notes 6 and 7	5.0	-	ns

NOTES: See Page 26.



**TABLE 3 - ELECTRICAL MEASUREMENTS AT HIGH AND LOW TEMPERATURES - a.c. PARAMETERS
(CONTINUED)**

NO.	CHARACTERISTICS	SYMBOL	TEST METHOD MIL-STD 883	TEST FIG.	TEST CONDITIONS (PINS UNDER TEST)	LIMITS		UNIT
						MIN	MAX	
131 to 132	Output Disable Time (CS High)	TEHQZ	-	4(k)	V _{DD} = 4.5V and 5.5V V _{SS} = 0V Notes 6 and 7 Variants 1-2-3 Variants 4-5-6 Variants 7-8-9 Variants 10-11-12	-	55 45 55 45	ns
133 to 134	Output Disable Time (W Low)	TWLQZ	-	4(k)	V _{DD} = 4.5V and 5.5V V _{SS} = 0V Notes 6 and 7 Variants 1-2-3 Variants 4-5-6 Variants 7-8-9 Variants 10-11-12	50 40 50 40	- - - -	ns
135 to 136	Output Enable Time (W High)	TWHQX	-	4(k)	V _{DD} = 4.5V and 5.5V V _{SS} = 0V Notes 6 and 7	0	-	ns

NOTES: See Page 26.

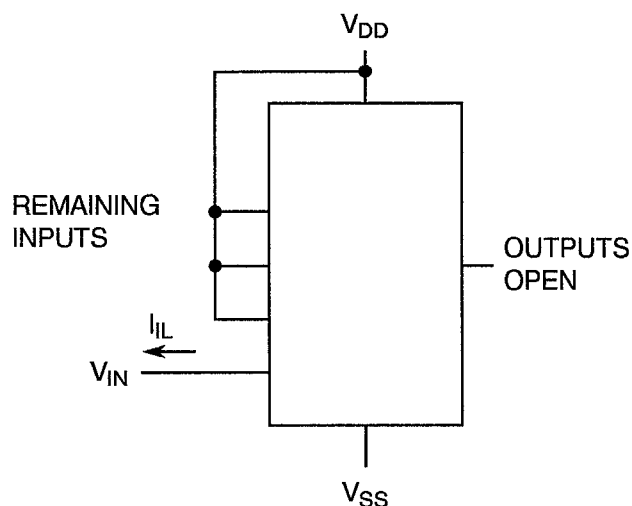
FIGURE 4 - CIRCUITS FOR ELECTRICAL MEASUREMENTS
FIGURE 4(a) - INPUT CURRENT LOW LEVEL

NOTES

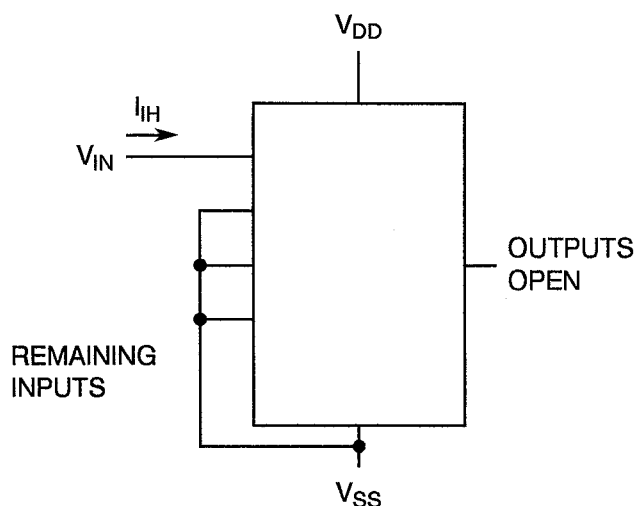
1. Each input to be tested separately.

FIGURE 4(b) - INPUT CURRENT HIGH LEVEL

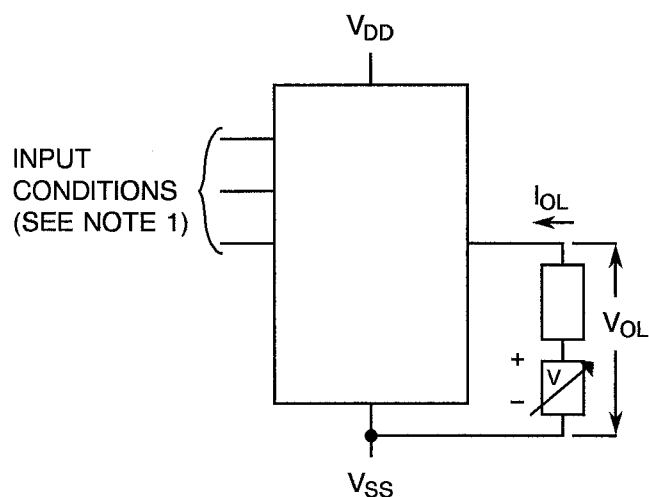
NOTES

1. Each input to be tested separately.

FIGURE 4(c) - OUTPUT VOLTAGE LOW LEVEL

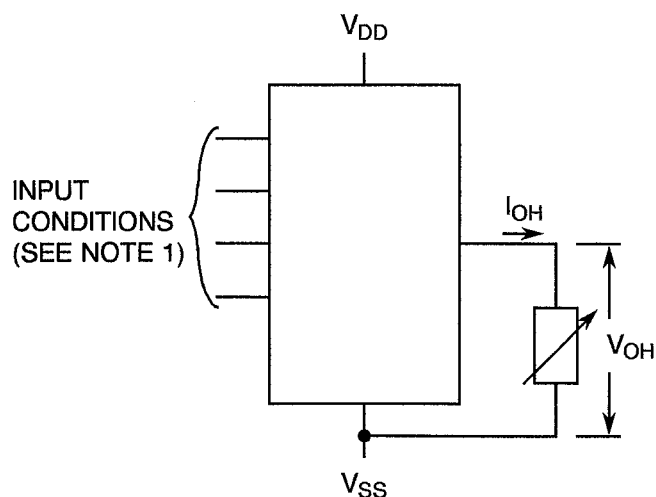
NOTES

1. $V_{IN} = V_{IL}$ (max.) and/or V_{IH} (min.) as per Truth Table to give V_{OL} .
2. Each output to be tested separately.

FIGURE 4(d) - OUTPUT VOLTAGE HIGH LEVEL

NOTES

1. $V_{IN} = V_{IL}$ (max.) and/or V_{IH} (min.) as per Truth Table to give V_{OH} .
2. Each output to be tested separately.

FIGURE 4 - CIRCUITS FOR ELECTRICAL MEASUREMENTS (CONTINUED)

FIGURE 4(e) - INPUT CLAMP VOLTAGE

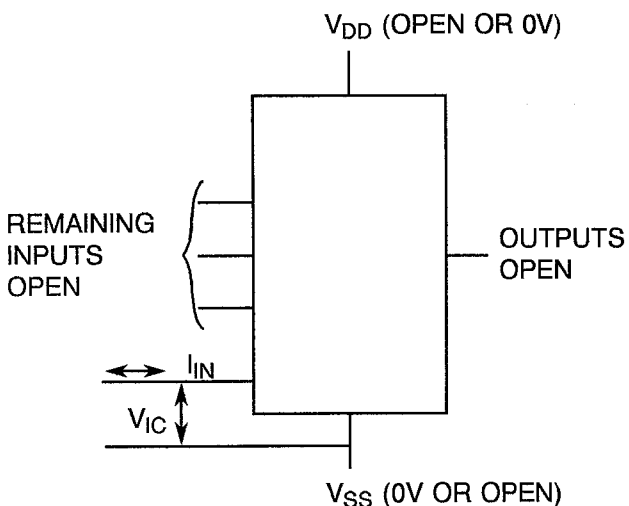
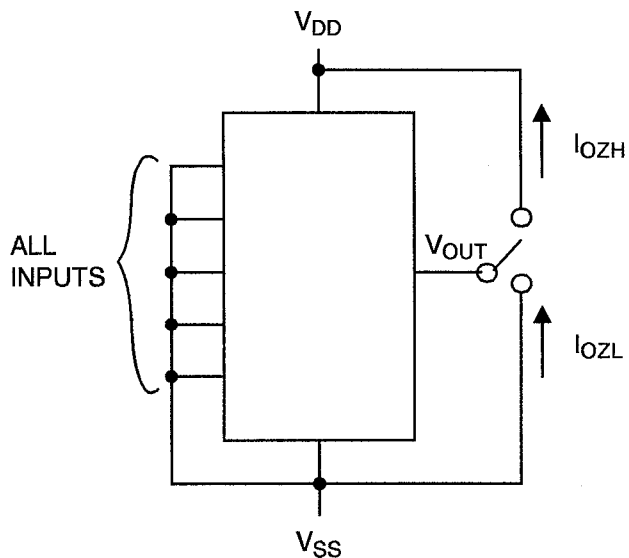

FIGURE 4(f) - OUTPUT LEAKAGE CURRENT THIRD STATE



NOTES

1. Each input to be tested separately.

FIGURE 4(g) - SUPPLY CURRENT

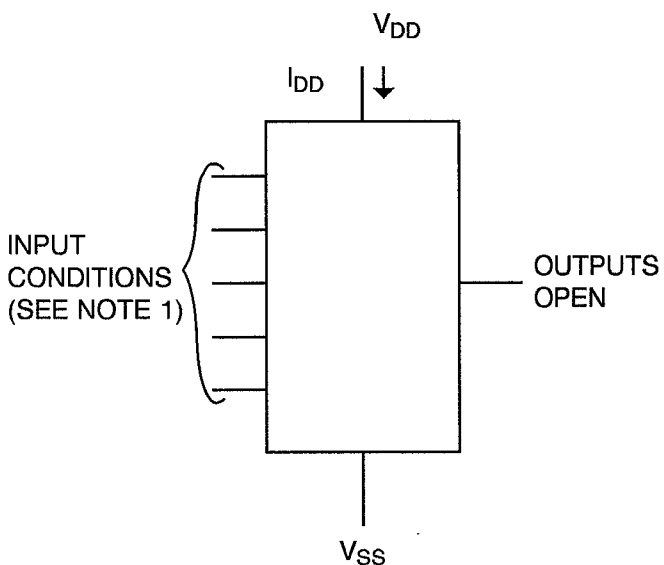
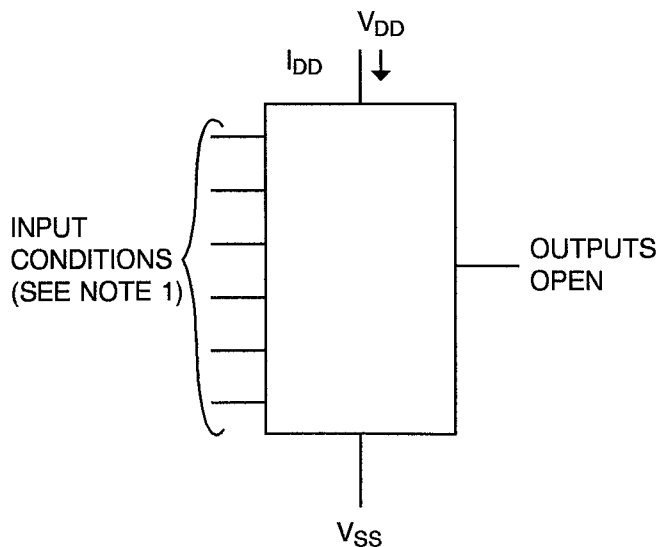

FIGURE 4(h) - DATA RETENTION CURRENT



NOTES

1. As per Table 2 or 3.

NOTES

1. Procedure as per Note 4 to Table 2.

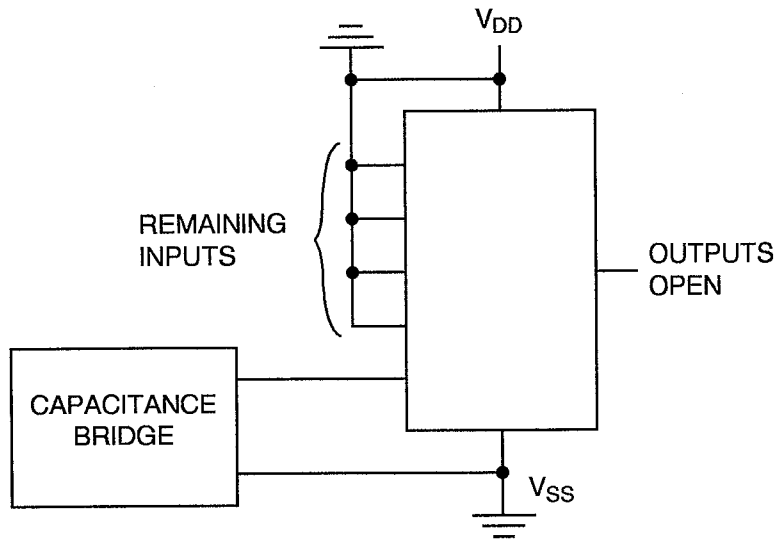
FIGURE 4 - CIRCUITS FOR ELECTRICAL MEASUREMENTS (CONTINUED)
FIGURE 4(i) - INPUT CAPACITANCE

NOTES

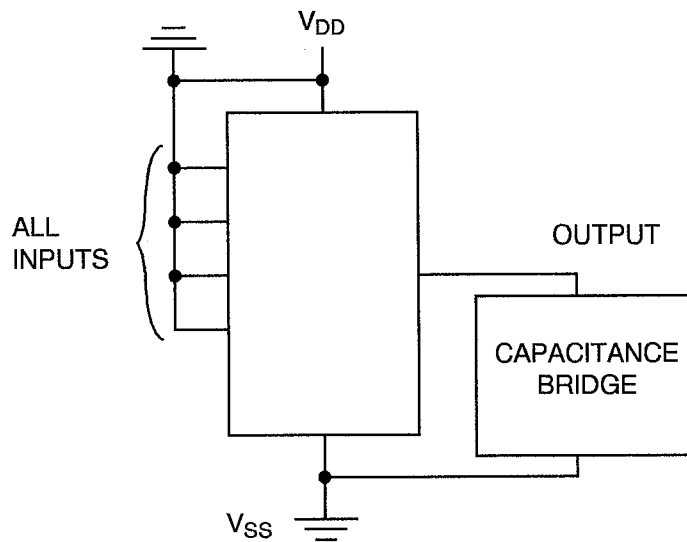
1. Each input to be tested separately.
2. $f = 100\text{kHz}$ to 1MHz .

FIGURE 4(j) - OUTPUT CAPACITANCE

NOTES

1. $f = 100\text{kHz}$ to 1MHz .

FIGURE 4 - CIRCUITS FOR ELECTRICAL MEASUREMENTS (CONTINUED)

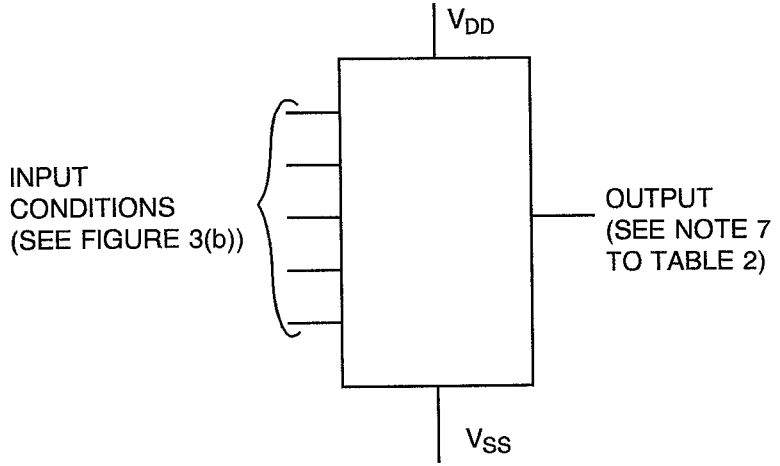
FIGURE 4(k) - PROPAGATION DELAY



TIMING WAVEFORMS

READ CYCLE 1

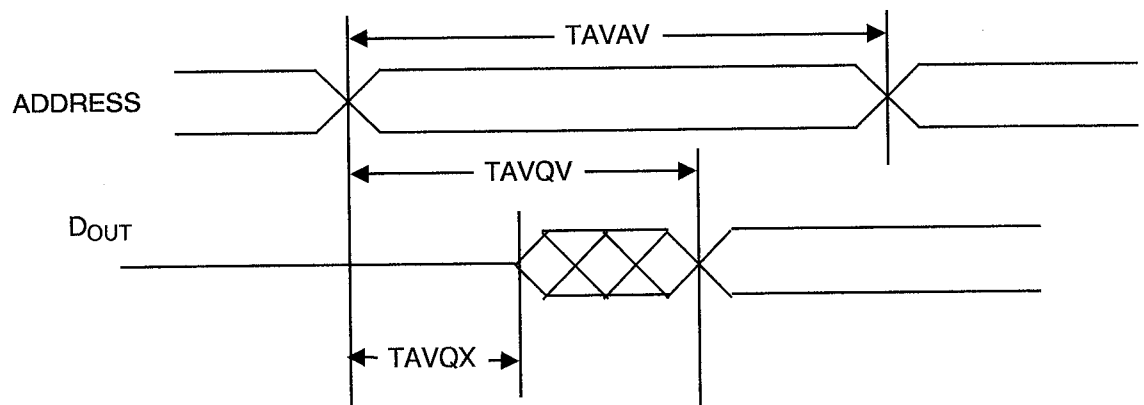

READ CYCLE 2

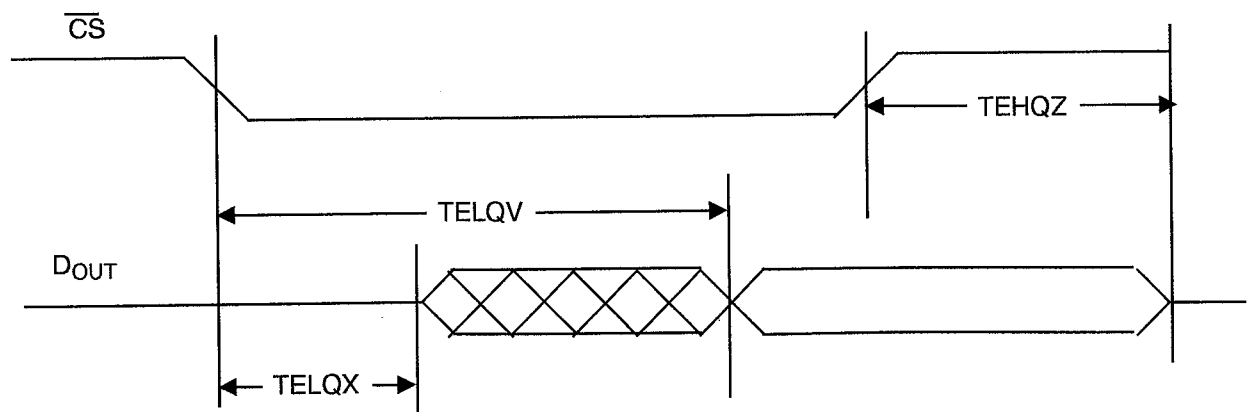



FIGURE 4 - CIRCUITS FOR ELECTRICAL MEASUREMENTS (CONTINUED)

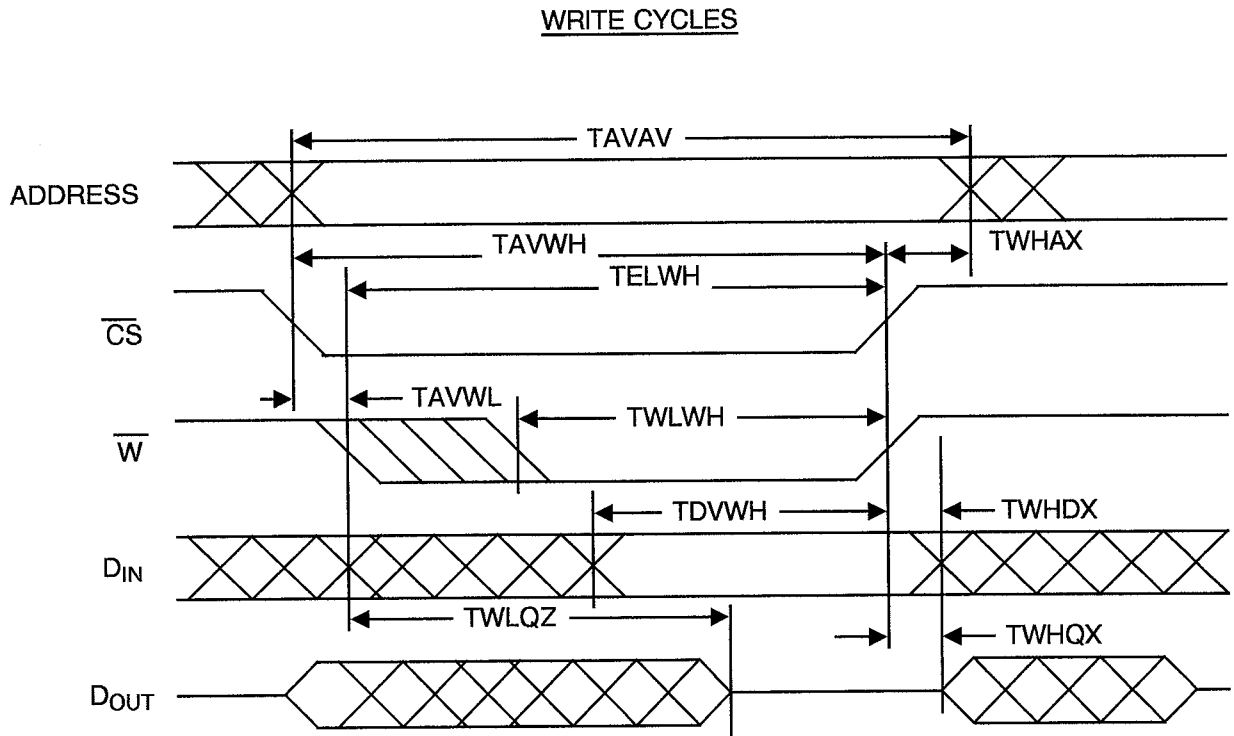



TABLE 4 - PARAMETER DRIFT VALUES

NO.	CHARACTERISTICS	SYMBOL	SPEC. AND/OR TEST METHOD	TEST CONDITIONS	CHANGE LIMITS (Δ)	UNIT
17 to 35	Input Current Low Level	I_{IL}	As per Table 2	As per Table 2	± 100	nA
36 to 54	Input Current High Level	I_{IH}	As per Table 2	As per Table 2	± 100	nA
55	Output Voltage Low Level	V_{OL}	As per Table 2	As per Table 2	± 100	mV
56	Output Voltage High Level	V_{OH}	As per Table 2	As per Table 2	± 100	mV
77	Output Leakage Current Third State Low Level Applied	I_{OZL}	As per Table 2	As per Table 2	± 100	nA
78	Output Leakage Current Third State High Level Applied	I_{OZH}	As per Table 2	As per Table 2	± 100	nA
79	Supply Current 1 (Standby)	I_{DDBS1}	As per Table 2	As per Table 2 Variants 1-2-3 Variants 4-5-6 Variants 7-8-9 Variants 10-11-12	± 1.5 ± 1.5 ± 2.0 ± 2.0	mA
80	Supply Current 2 (Standby)	I_{DDBS2}	As per Table 2	As per Table 2 Variants 1-2-3 Variants 4-5-6 Variants 7-8-9 Variants 10-11-12	± 5.0 ± 5.0 ± 50 ± 50	μ A
81	Data Retention Current	I_{DDDR}	As per Table 2	As per Table 2 Variants 1-2-3 Variants 4-5-6 Variants 7-8-9 Variants 10-11-12	± 2.0 ± 2.0 ± 20 ± 20	μ A

**TABLE 5 - CONDITIONS FOR POWER BURN-IN AND OPERATING LIFE TEST**

NO.	CHARACTERISTICS	SYMBOL	CONDITIONS	UNIT
1	Ambient Temperature	T_{amb}	+125(+0-5)	°C
2	Inputs - (Pins 1-2-3-4-5-6-7-8-13-14-15-16-17-18-19-20-21)	V_{IN}	f_0 to f_{14}	Vac
3	Inputs - (Pins 10-12)	V_{IN}	$\overline{CS}, \overline{W}$ (Note 1)	Vac
4	Output - (Pin 9)	V_{OUT}	V_{SS} or V_{DD}	V
5	Pulse Voltage	V_{GEN}	0 to V_{DD}	Vac
6	Pulse Frequency	f_0	50k ± 20% 50 ± 15% Duty Cycle	Hz
7	Positive Supply Voltage (Pin 22)	V_{DD}	5.0(+0.5-0)	V
8	Negative Supply Voltage (Pin 11)	V_{SS}	0	V

NOTES

- $f_n = \frac{1}{2}(f_n - 1)$.
- Input Timing:

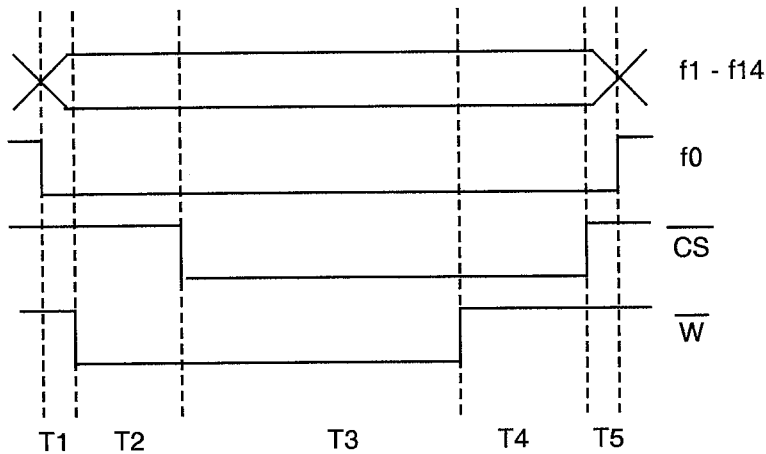

- T1 = 0.6 μ s
- T2 = 0.3 μ s
- T3 = 3.6 μ s
- T4 = 4.6 μ s
- T5 = 0.9 μ s



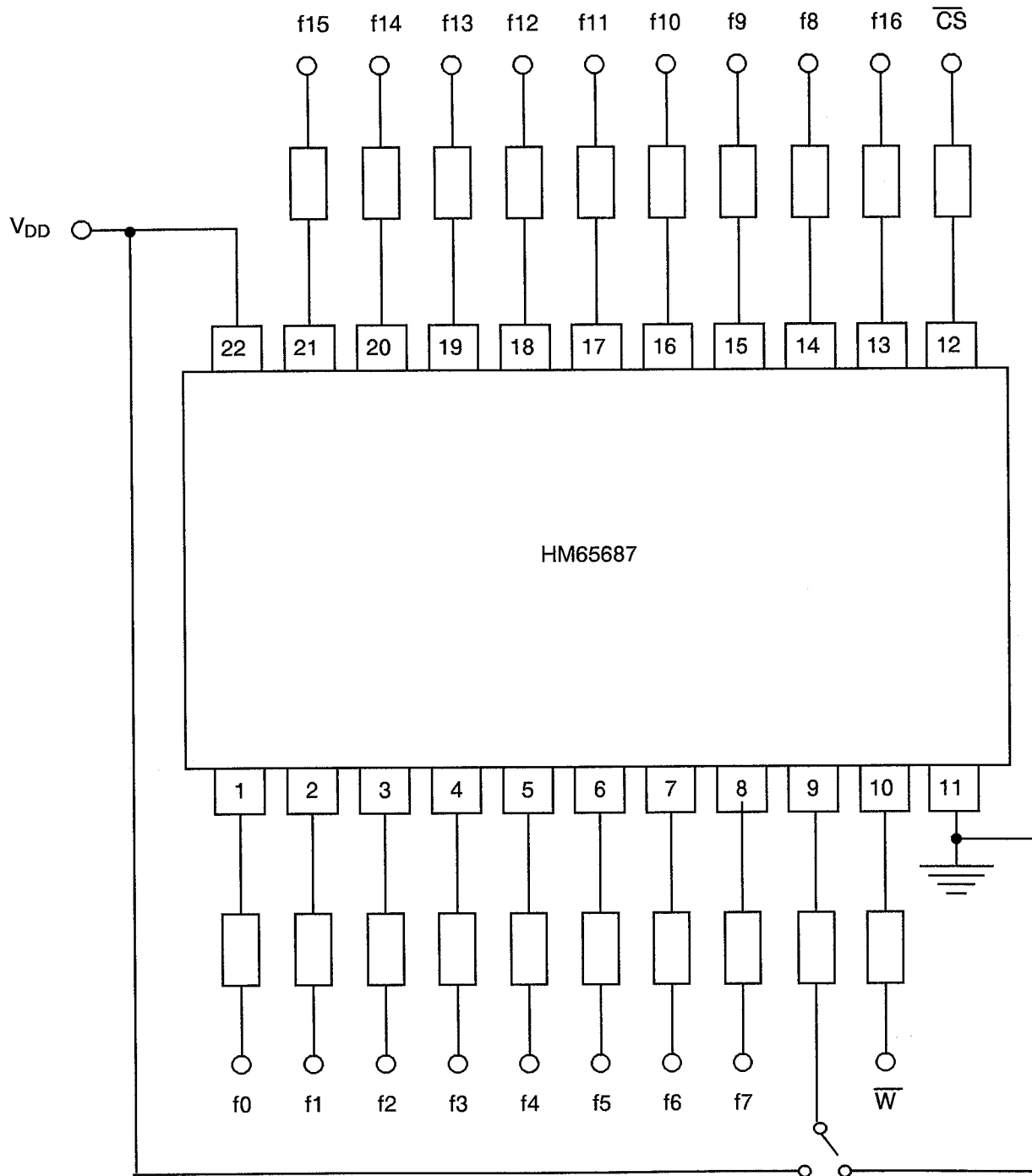

FIGURE 5 - ELECTRICAL CIRCUIT FOR POWER BURN-IN AND OPERATING LIFE TEST



NOTES

1. Input Protection Resistor = Output Load Resistor = 1.0kΩ.

 	ESA/SCC Detail Specification No. 9301/026	PAGE 42 ISSUE 1
---	--	--------------------

4.8 ENVIRONMENTAL AND ENDURANCE TESTS (CHARTS IV AND V OF ESA/SCC GENERIC SPECIFICATION No. 9000)

4.8.1 Electrical Measurements on Completion of Environmental Tests

The parameters to be measured on completion of environmental tests are scheduled in Table 2. Unless otherwise stated, the measurements shall be performed at $T_{amb} = +22 \pm 3$ °C.

4.8.2 Electrical Measurements at Intermediate Points during Endurance Tests

The parameters to be measured at intermediate points during endurance testing are as scheduled in Table 6 of this specification. Unless otherwise stated, the measurements shall be performed at $T_{amb} = +22 \pm 3$ °C.

4.8.3 Electrical Measurements on Completion of Endurance Tests

The parameters to be measured on completion of endurance testing are as scheduled in Table 6 of this specification. Unless otherwise stated, the measurements shall be performed at $T_{amb} = +22 \pm 3$ °C.

4.8.4 Conditions for Operating Life Tests

The requirements for operating life testing are specified in Section 9 of ESA/SCC Generic Specification No. 9000. The conditions for operating life testing shall be as specified in Table 5 of this specification.

4.8.5 Electrical Circuits for Operating Life Tests

Circuits for use in performing the operating life tests are shown in Figure 5 of this specification.

4.8.6 Conditions for High Temperature Storage Test

The requirements for the high temperature storage test are specified in ESA/SCC Generic Specification No. 9000. The temperature to be applied shall be the maximum storage temperature specified in Table 1(b) of this specification.

4.9 TOTAL DOSE IRRADIATION TESTING

4.9.1 Application

If specified in Para. 4.2.1 of this specification, total dose irradiation testing shall be performed in accordance with the requirements of ESA/SCC Basic Specification No. 22900.

4.9.2 Bias Conditions

Continuous bias shall be applied during irradiation testing as shown in Figure 6 of this specification.

4.9.3 Electrical Measurements

The parameters to be measured prior to irradiation exposure are scheduled in Table 2 of this specification. Only devices which meet the requirements of Table 2 shall be included in the test sample.

The parameters to be measured during and on completion of irradiation testing are scheduled in Table 7 of this specification.

TABLE 6 - ELECTRICAL MEASUREMENTS AT INTERMEDIATE POINTS AND ON COMPLETION OF ENDURANCE TESTING

NO.	CHARACTERISTICS	SYMBOL	SPEC. AND/OR TEST METHOD	TEST CONDITIONS	LIMITS		UNIT
					MIN	MAX	
1 to 6	Functional Test 1 (Nominal Inputs)	-	As per Table 2	As per Table 2	-	-	-
7 to 12	Functional Test 2 (Worst Case Inputs)	-	As per Table 2	As per Table 2	-	-	-
13 to 16	Functional Test 3 (Worst Case Outputs)	-	As per Table 2	As per Table 2	-	-	-
17 to 35	Input Current Low Level	I_{IL}	As per Table 2	As per Table 2	-1.0	+1.0	μA
36 to 54	Input Current High Level	I_{IH}	As per Table 2	As per Table 2	-1.0	+1.0	μA
55	Output Voltage Low Level	V_{OL}	As per Table 2	As per Table 2	-	0.4	V
56	Output Voltage High Level	V_{OH}	As per Table 2	As per Table 2	2.4	-	V
57 to 75	Input Clamp Voltage (to V_{SS})	V_{IC}	As per Table 2	As per Table 2	-0.2	-2.0	V
76	Output Leakage Current Third State (Low Level Applied)	I_{OZL}	As per Table 2	As per Table 2	-1.0	+1.0	μA
77	Output Leakage Current Third State (High Level Applied)	I_{OZH}	As per Table 2	As per Table 2	-1.0	+1.0	μA
78	Supply Current (Operating)	I_{DDop}	As per Table 2	As per Table 2 Variants 1-2-3 Variants 4-5-6 Variants 7-8-9 Variants 10-11-12	- - - -	75 75 100 100	mA
79	Supply Current 1 (Standby)	I_{DDSB1}	As per Table 2	As per Table 2 Variants 1-2-3 Variants 4-5-6 Variants 7-8-9 Variants 10-11-12	- - - -	15 15 20 20	mA

TABLE 6 - ELECTRICAL MEASUREMENTS AT INTERMEDIATE POINTS AND ON COMPLETION OF ENDURANCE TESTING (CONTINUED)

NO.	CHARACTERISTICS	SYMBOL	SPEC. AND/OR TEST METHOD	TEST CONDITIONS	LIMITS		UNIT
					MIN	MAX	
80	Supply Current 2 (Standby)	I _{DDSB2}	As per Table 2	As per Table 2 Variants 1-2-3 Variants 4-5-6 Variants 7-8-9 Variants 10-11-12	- - - -	50 50 500 500	μA
81	Data Retention Current	I _{DDDR}	As per Table 2	As per Table 2 Variants 1-2-3 Variants 4-5-6 Variants 7-8-9 Variants 10-11-12	- - - -	20 20 200 200	μA
82	Data Retention	DR	As per Table 2	As per Table 2	-	-	-

FIGURE 6 - BIAS CONDITIONS FOR IRRADIATION TESTING

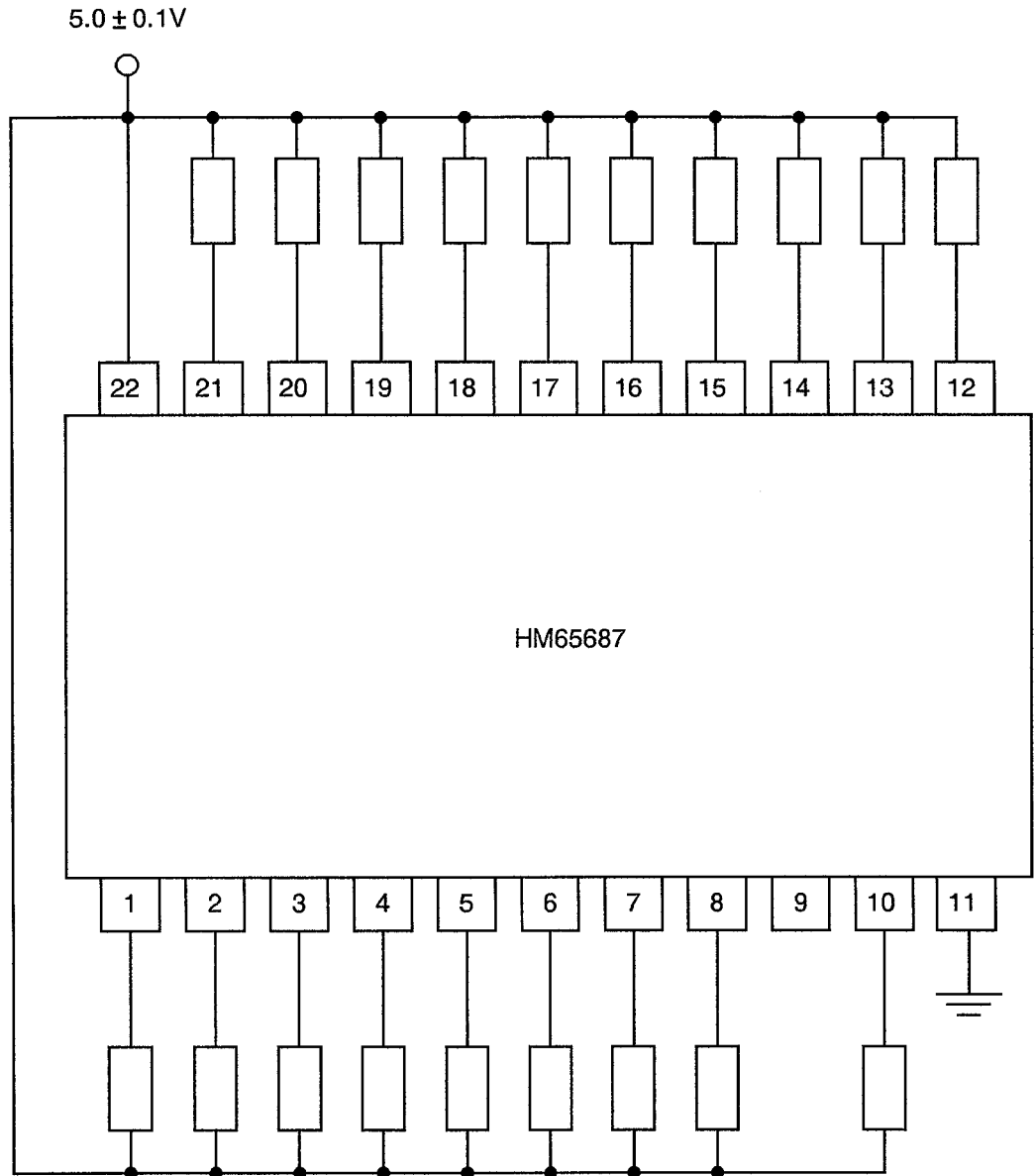

NOTES

1. Input Protection Resistor = 1.0kΩ.

TABLE 7 - ELECTRICAL MEASUREMENTS DURING AND ON COMPLETION OF IRRADIATION TESTING

No.	CHARACTERISTICS	SYMBOL	SPEC. AND/OR TEST METHOD	TEST CONDITIONS	LIMITS		UNIT
					MIN	MAX	
1 to 6	Functional Test 1 (Nominal Inputs)	-	As per Table 2	As per Table 2	-	-	-
17 to 35	Input Current Low Level	I_{IL}	As per Table 2	As per Table 2	-5.0	+5.0	μ A
36 to 54	Input Current High Level	I_{IH}	As per Table 2	As per Table 2	-5.0	+5.0	μ A
55	Output Voltage Low Level	V_{OL}	As per Table 2	As per Table 2	-	0.4	V
56	Output Voltage High Level	V_{OH}	As per Table 2	As per Table 2	2.4	-	V
76	Output Leakage Current Third State (Low Level Applied)	I_{OZL}	As per Table 2	As per Table 2	-5.0	+5.0	μ A
77	Output Leakage Current Third State (High Level Applied)	I_{OZH}	As per Table 2	As per Table 2	-5.0	+5.0	μ A
80	Supply Current (Standby)	I_{DDSB}	As per Table 2	As per Table 2 Variants 1-2-3 Variants 4-5-6 Variants 7-8-9 Variants 10-11-12	- - - -	1.0 1.0 5.0 5.0	mA

	<p>ESA/SCC Detail Specification No. 9301/026</p>	<p>PAGE 47 ISSUE 1</p>
---	--	----------------------------

APPENDIX 'A'

Page 1 of 4

AGREED DEVIATIONS FOR MATRA-MHS (F)

The following test patterns may be used:-

ICCACT Pattern

- (a) Write loop pattern between N min. and N max.

WALKCOL Pattern

- (a) Write a column of ones on a background of zeros.
- (b) Read the column and background, step the column and repeat the read.
- (c) Continue until all columns have been used.
- (d) Repeat with data complement.
- (e) 4YN + 2Y + 2 cycles.

CHIP DESELECT Pattern

- (a) Write 0 background \overline{CS} at VIL.
- (b) Write 1 background \overline{CS} at VIL.
- (c) Read 1 background \overline{CS} at VIL.
- (d) Write 0 background \overline{CS} at VIH.
- (e) Read 1 background CS at VIL.

LONG CHIP SELECT Pattern

Checkerboard pattern with timing unspecified.



APPENDIX 'A'

COMARCH Pattern

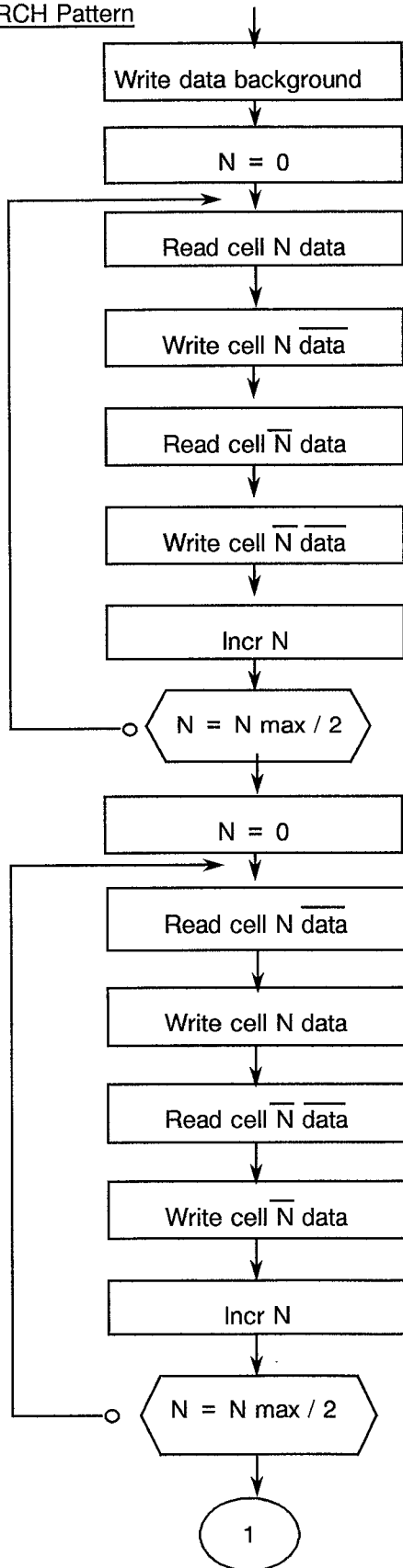

Memory Size	65536
Data	1
N max.	65535

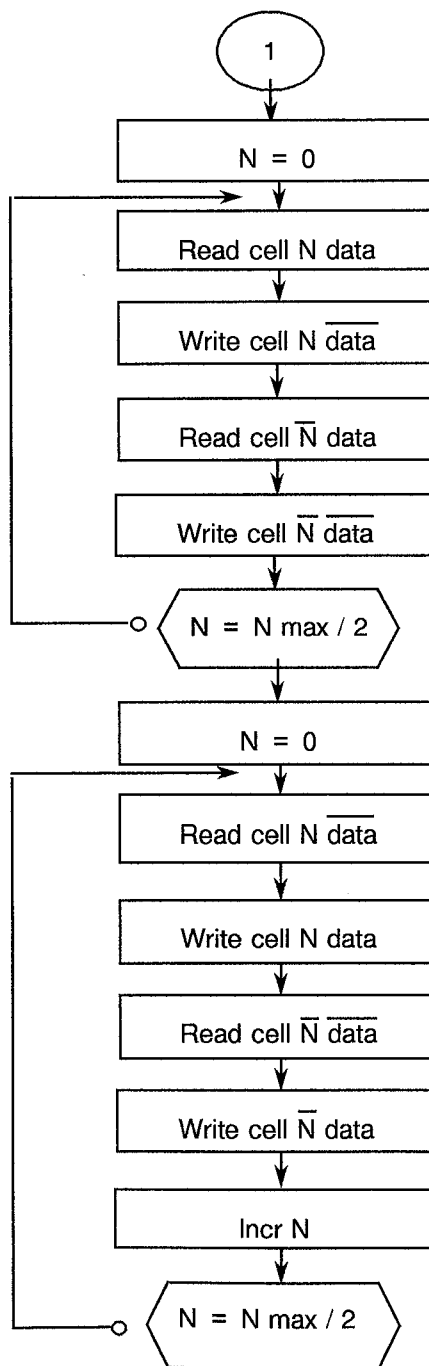



APPENDIX 'A'

MARCH Pattern

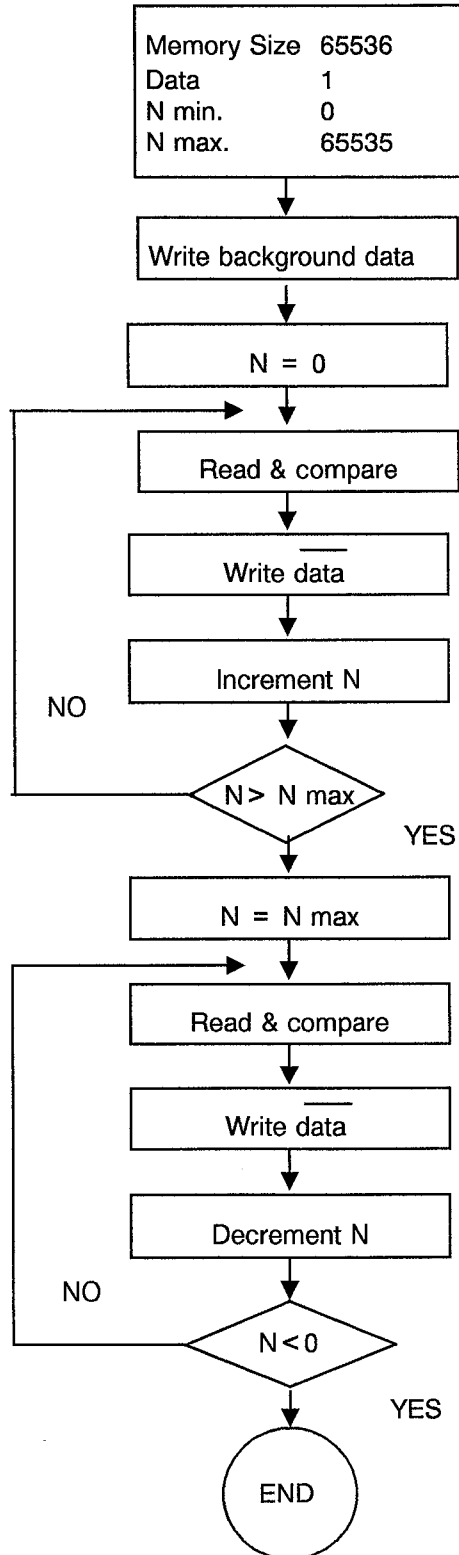



APPENDIX 'A'

CHECKERBOARD Pattern

