



europaean space agency  
agence spatiale europeenne

Pages 1 to 32

**INTEGRATED CIRCUITS, SILICON MONOLITHIC,  
BIPOLAR, ADVANCED LOW POWER SCHOTTKY,  
8-BIT, UNIVERSAL SHIFT/STORAGE REGISTERS  
WITH DIRECT OVERRIDING CLEAR AND  
3-STATE OUTPUTS,  
BASED ON TYPE 54ALS299**

**ESA/SCC Detail Specification No. 9306/039**



**space components  
coordination group**

Issue/Rev.	Date	Approved by	
		SCCG Chairman	ESA Director General or his Deputy
Issue 2	February 1992	<i>Pommerehne</i>	<i>J. L. ...</i>
Revision 'A'	June 1994	<i>Pommerehne</i>	<i>... ..</i>



**DOCUMENTATION CHANGE NOTICE**

Rev. Letter	Rev. Date	Reference	CHANGE Item	Approved DCR No.
		This Issue supersedes Issue 1 and incorporates all modifications defined in Revision 'A' to Issue 1 and the following DCR's:-		
		Cover Page		None
		DCN		None
		Table 1(a)	: Lead Material and/or Finish amended	22881
			: Variant 02 added and Figure references amended	22920
		Figures 2	: Imperial dimensions and references deleted	22881
		Figure 2(a)	: New Figure 2(a) added and previous Figures 2(a) and 2(b) renumbered "2(b)" and "2(c)".	22920
		Figure 2(c)	: In drawing, Note 6 corrected to "10".	23456
		Notes to Figures	: Title amended	22881
			: Note 1, amended to read "...Figure 2(b)"	22881
			: Note 2, text added	22920
			: Note 9, text amended	22920
		Figure 3(a)	: DIL subtitle amended	22920
		Figure 3(b)	: Notes 2 and 3 added	23456
		Para. 4.2.2	: Deviation deleted, "None." added	21048
		Para. 4.2.4	: Deviation deleted, "None." added	22919
		Para. 4.2.5	: Deviation deleted, "None." added	22919
		Para. 4.3.2	: Flat package weight added	22920
		Para. 4.4.2	: Paragraph amended	22881/ 22920
		Para. 4.5.2	: Paragraph amended	22881/ 22920
		Para. 4.5.3	: "Type Variant, as applicable" amended to refer to Table 1(a)	23455
		Para. 4.6.3	: Reference to functional test sequence deleted	23455
		Para. 4.7.1	: Expanded to identify the stated temperature as $T_{amb}$	23455
		Figure 4(c)	: Control Input connection deleted	23456
		Figure 4(f)	: In Note 1, "shorted" amended to read "tested"	23455
		Para. 4.8	: Title expanded	23455
'A'	June '94	P1. Cover Page P2. DCN P14. Para. 4.3.2	: Weights amended	None None 221047

**TABLE OF CONTENTS**

	<u>Page</u>
<b>1. <u>GENERAL</u></b>	<b>5</b>
1.1 Scope	5
1.2 Component Type Variants	5
1.3 Maximum Ratings	5
1.4 Parameter Derating Information	5
1.5 Physical Dimensions	5
1.6 Pin Assignment	5
1.7 Truth Table	5
1.8 Circuit Schematic	5
1.9 Functional Diagram	5
<b>2. <u>APPLICABLE DOCUMENTS</u></b>	<b>13</b>
<b>3. <u>TERMS, DEFINITIONS, ABBREVIATIONS, SYMBOLS AND UNITS</u></b>	<b>13</b>
<b>4. <u>REQUIREMENTS</u></b>	<b>13</b>
4.1 General	13
4.2 Deviations from Generic Specification	13
4.2.1 Deviations from Special In-process Controls	13
4.2.2 Deviations from Final Production Tests	13
4.2.3 Deviations from Burn-in Tests	13
4.2.4 Deviations from Qualification Tests	13
4.2.5 Deviations from Lot Acceptance Tests	14
4.3 Mechanical Requirements	14
4.3.1 Dimension Check	14
4.3.2 Weight	14
4.4 Materials and Finishes	14
4.4.1 Case	14
4.4.2 Lead Material and Finish	14
4.5 Marking	14
4.5.1 General	14
4.5.2 Lead Identification	14
4.5.3 The SCC Component Number	15
4.5.4 Traceability Information	15
4.6 Electrical Measurements	15
4.6.1 Electrical Measurements at Room Temperature	15
4.6.2 Electrical Measurements at High and Low Temperatures	15
4.6.3 Circuits for Electrical Measurements	15
4.7 Burn-in Tests	15
4.7.1 Parameter Drift Values	15
4.7.2 Conditions for Power Burn-in	15
4.7.3 Electrical Circuits for Power Burn-in	15
4.8 Environmental and Endurance Tests	30
4.8.1 Electrical Measurements on Completion of Environmental Tests	30
4.8.2 Electrical Measurements at Intermediate Points during Endurance Tests	30
4.8.3 Electrical Measurements on Completion of Endurance Tests	30
4.8.4 Conditions for Operating Life Tests	30
4.8.5 Electrical Circuits for Operating Life Tests	30
4.8.6 Conditions for High Temperature Storage Test	30



Page

**TABLES**

1(a)	Type Variants	6
1(b)	Maximum Ratings	6
2	Electrical Measurements at Room Temperature, d.c. Parameters	16
	Electrical Measurements at Room Temperature, a.c. Parameters	18
3	Electrical Measurements at High and Low Temperatures	22
4	Parameter Drift Values	28
5	Conditions for Power Burn-in and Operating Life Test	28
6	Electrical Measurements on Completion of Environmental Tests and at Intermediate Points and on Completion of Endurance Tests	31

**FIGURES**

1	Not applicable	
2	Physical Dimensions	7
3(a)	Pin Assignment	11
3(b)	Truth Table	11
3(c)	Circuit Schematic	12
3(d)	Functional Diagram	12
4	Circuits for Electrical Measurements	24
5	Electrical Circuit for Power Burn-in and Operating Life Test	29

**APPENDICES (Applicable to specific Manufacturers only)**

'A'	Agreed Deviations for Texas Instruments (F)	32
-----	---	----

**1. GENERAL****1.1 SCOPE**

This specification details the ratings, physical and electrical characteristics, test and inspection data for a silicon monolithic, bipolar, advanced low power Schottky, 8-Bit, Universal Shift/Storage Register with Direct Overriding Clear and 3-State Outputs, based on Type 54ALS299. It shall be read in conjunction with ESA/SCC Generic Specification No. 9000, the requirements of which are supplemented herein.

**1.2 COMPONENT TYPE VARIANTS**

Variants of the basic type integrated circuits specified herein, which are also covered by this specification, are given in Table 1(a).

**1.3 MAXIMUM RATINGS**

The maximum ratings, which shall not be exceeded at any time during use or storage, applicable to the integrated circuits specified herein, are as scheduled in Table 1(b).

**1.4 PARAMETER DERATING INFORMATION (FIGURE 1)**

Not applicable.

**1.5 PHYSICAL DIMENSIONS**

The physical dimensions of the integrated circuits specified herein are shown in Figure 2.

**1.6 PIN ASSIGNMENT**

As per Figure 3(a).

**1.7 TRUTH TABLE**

As per Figure 3(b).

**1.8 CIRCUIT SCHEMATIC**

As per Figure 3(c).

**1.9 FUNCTIONAL DIAGRAM**

As per Figure 3(d).

**TABLE 1(a) - TYPE VARIANTS**

VARIANT	CASE	FIGURE	LEAD MATERIAL AND/OR FINISH
02	FLAT	2(a)	G4
03	CCP	2(b)	7
04	CCP	2(b)	4
05	DIL	2(c)	D7
06	DIL	2(c)	G4

**TABLE 1(b) - MAXIMUM RATINGS**

NO.	CHARACTERISTICS	SYMBOL	MAXIMUM RATINGS	UNIT	REMARKS
1	Supply Voltage	$V_{CC}$	-0.5 to 7.0	V	-
2	Input Voltage	$V_{IN}$	-0.5 to 7.0	V	Note 1
3	Input Voltage I/O Ports	$V_{IN}$	5.5	V	-
4	Device Dissipation	$P_D$	220	mWdc	Note 2
5	Operating Temperature Range	$T_{op}$	-55 to +125	°C	-
6	Storage Temperature Range	$T_{stg}$	-65 to +150	°C	-
7	Soldering Temperature For DIP For CCP	$T_{sol}$	+265 +245	°C	Note 3 Note 4

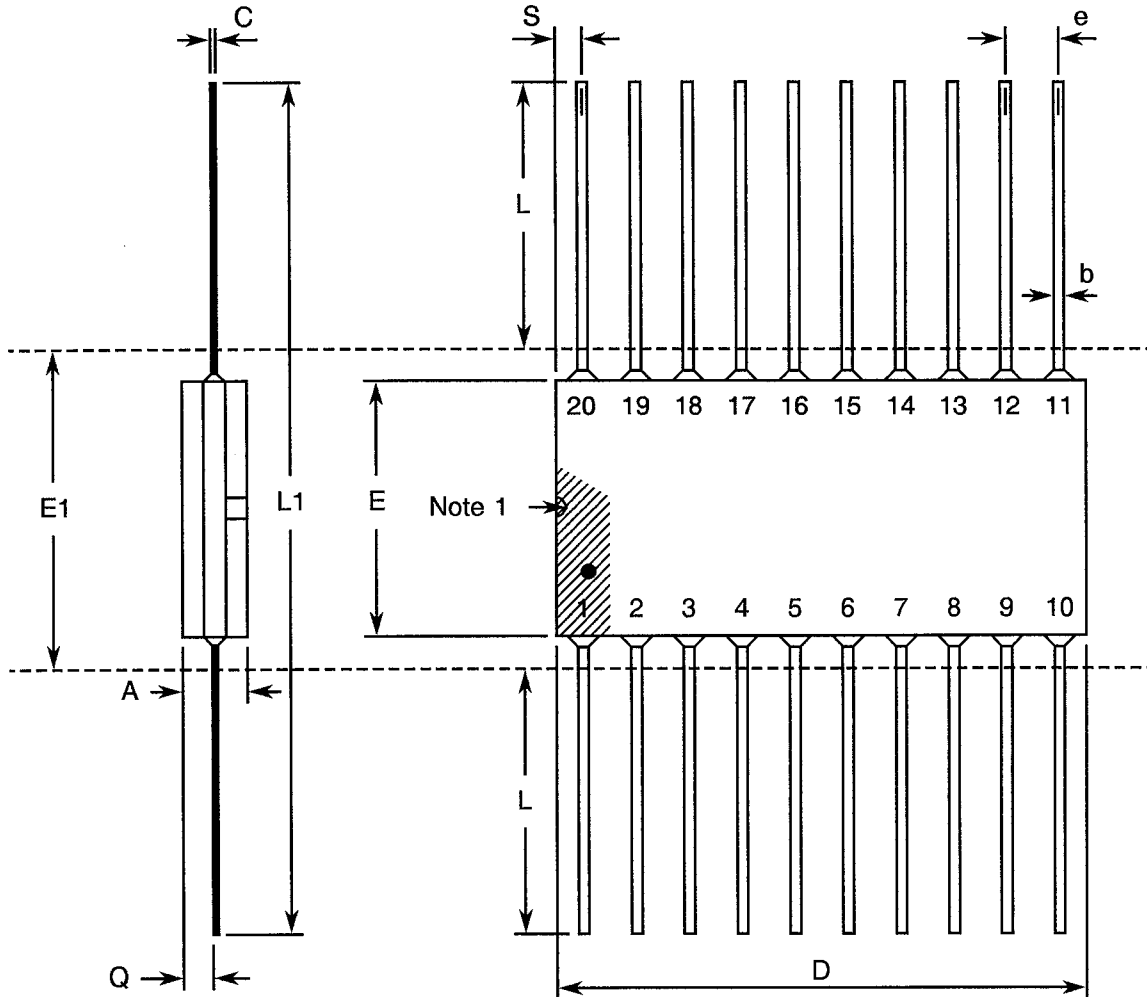
**NOTES**

1. Input Current limited to -18mA.
2. Must withstand added  $P_D$  due to short circuit conditions (i.e.  $I_{OS}$ ) at 1 output for 5 seconds.
3. Duration 10 seconds maximum at a distance of not less than 1.5mm from the package and the same lead shall not be resoldered until 3 minutes have elapsed.
4. Duration 5 seconds maximum and the same terminal shall not be resoldered until 3 minutes have elapsed.



**FIGURE 2 - PHYSICAL DIMENSIONS**

FIGURE 2(a) - FLAT PACKAGE



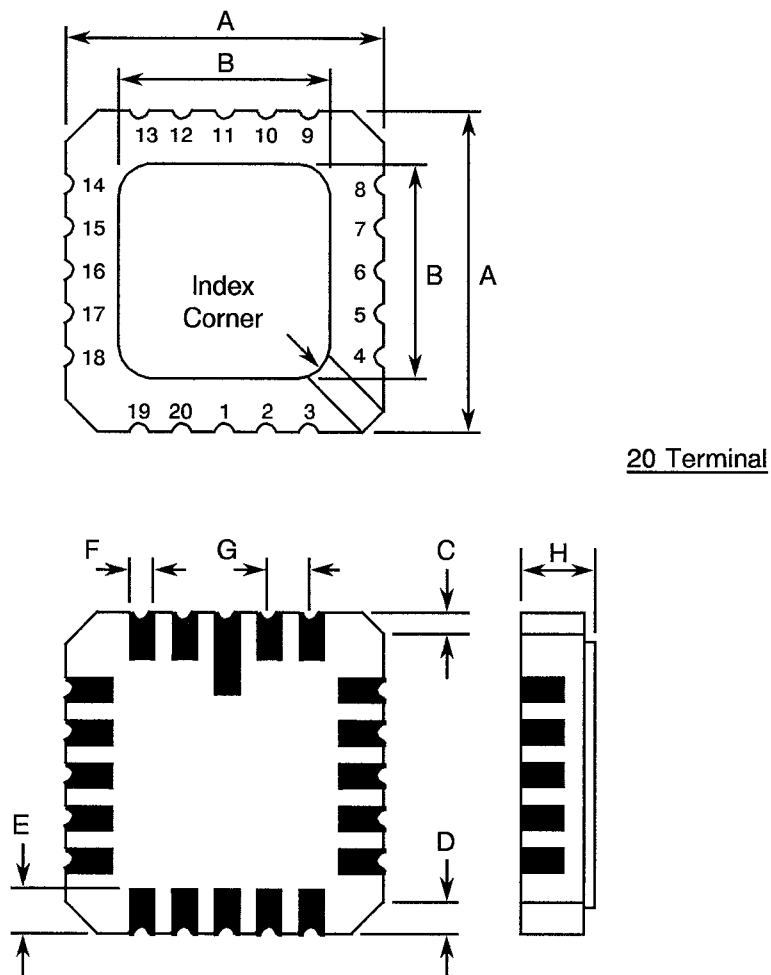
SYMBOL	MILLIMETRES		NOTES
	MIN	MAX	
A	1.14	2.34	
b	0.38	0.56	8
C	0.08	0.23	8
D	-	12.95	4
E	6.60	7.65	
E1	8.15 TYPICAL		4
e	1.27 TYPICAL		5, 9
L	6.35	9.40	8
L1	18.90	25.90	
Q	0.25	1.02	2
S	0.13	1.14	7

**NOTES:** See Page 10.



**FIGURE 2 - PHYSICAL DIMENSIONS**

**FIGURE 2(b) - SQUARE CHIP CARRIER PACKAGE (3 LAYER BASE)**



20 Terminal

SYMBOL	MILLIMETRES		NOTES
	MIN	MAX	
A	8.687	9.093	
B	7.798	9.093	
C	0.250	0.510	11
D	0.889	1.143	12
E	1.140	1.400	8
F	0.559	0.712	8
G	1.27 TYPICAL		5, 9
H	1.630	2.540	

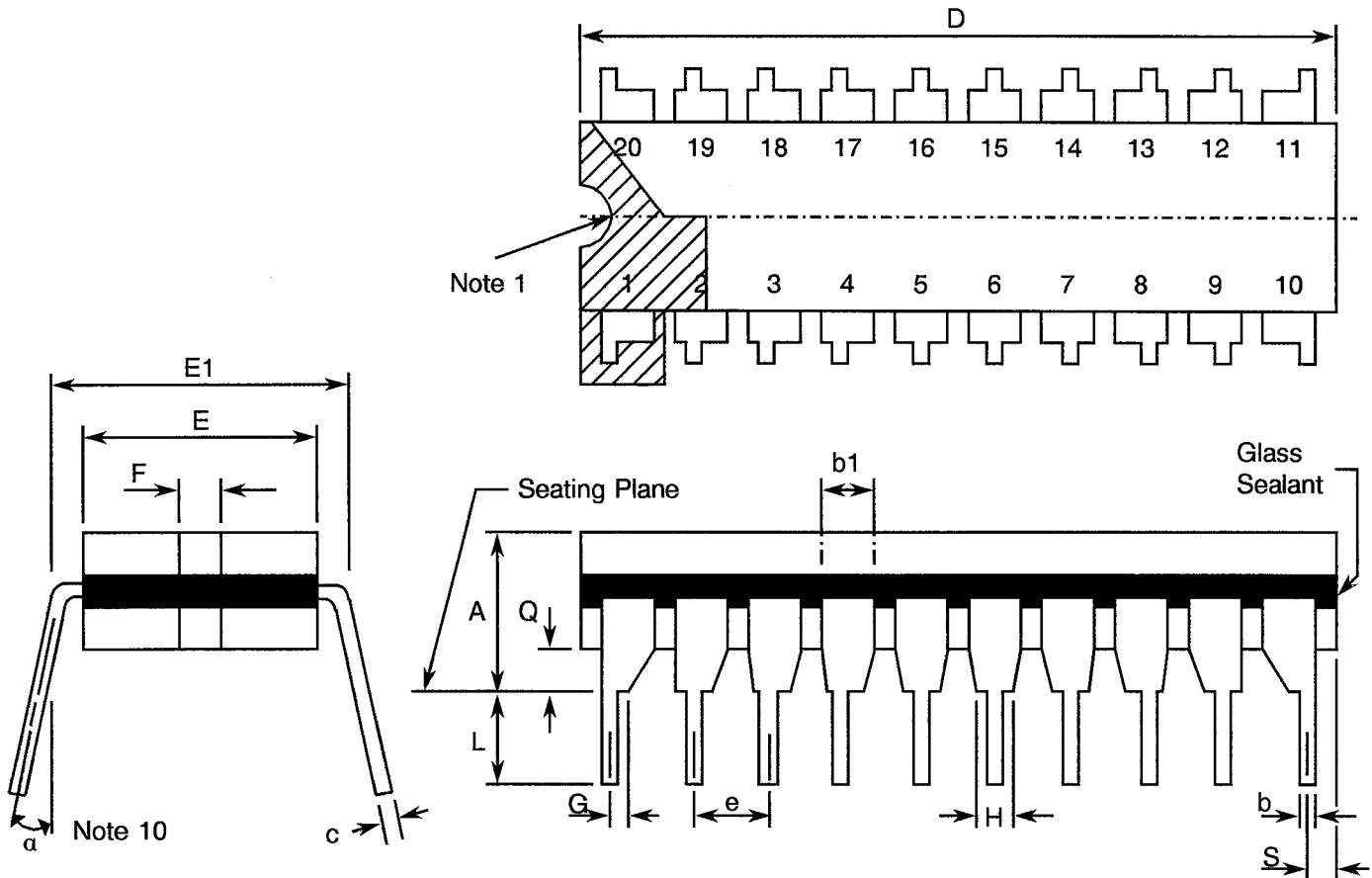
**NOTES:** See Page 10.







**FIGURE 2 - PHYSICAL DIMENSIONS (CONTINUED)**

**FIGURE 2(c) - DUAL-IN-LINE PACKAGE**



SYMBOL	MILLIMETRES		NOTES
	MIN	MAX	
A	-	5.08	
b	0.38	0.58	8
b1	0.76	1.78	8
c	0.203	0.356	8
D	23.62	24.76	
E	6.22	7.62	
E1	7.37	7.87	4
e	2.54 TYPICAL		6, 9
F	1.27 TYPICAL		
G	0.305	-	13
H	0.76	-	14
L	3.30	5.08	
Q	0.51	2.03	3
S	0.38	1.27	7
alpha	0°	15°	10

**NOTES:** See Page 10.

		<p style="text-align: center;">ESA/SCC Detail Specification No. 9306/039</p>		<p>PAGE 10 ISSUE 2</p>
---	---	--	--	----------------------------

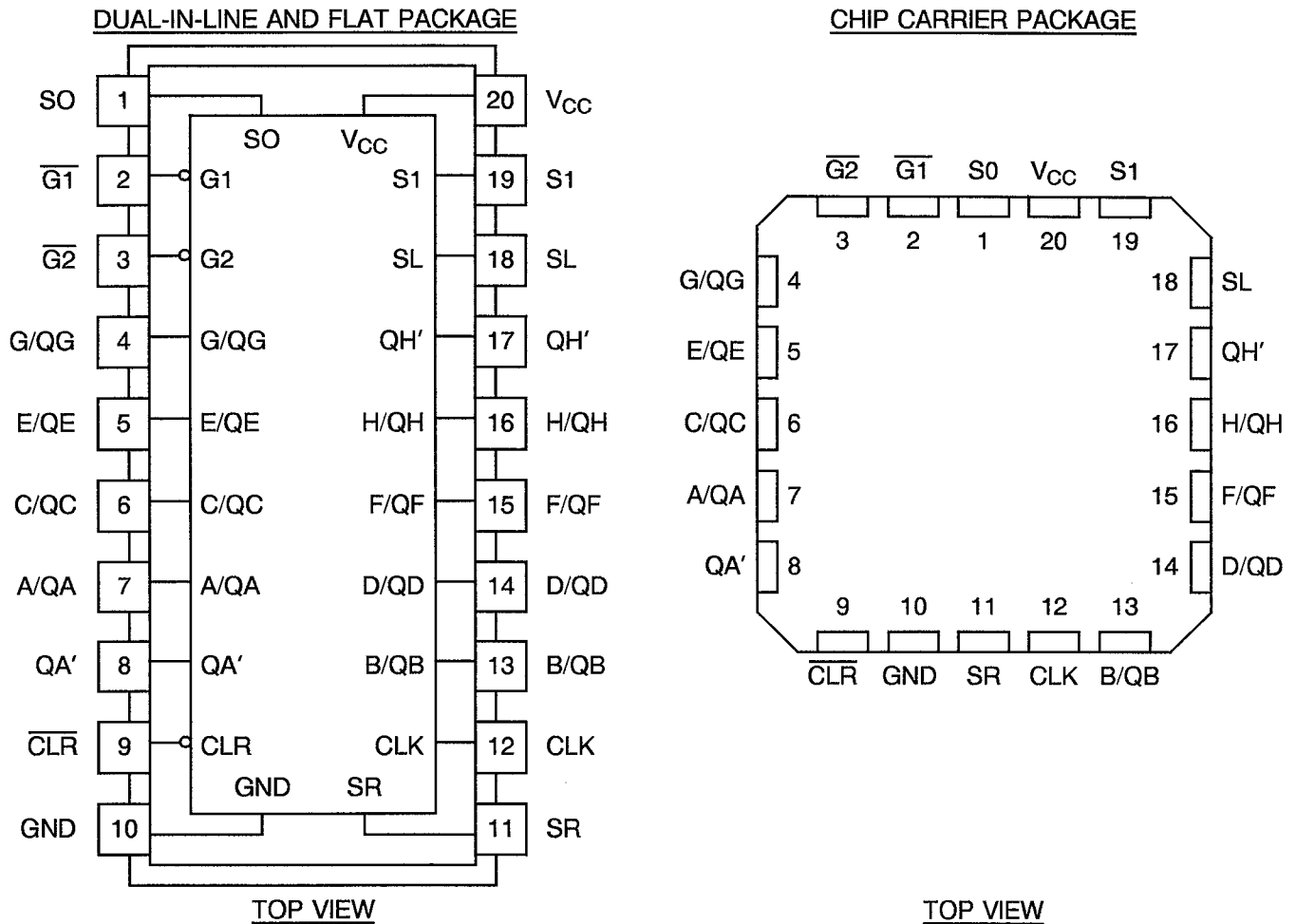
**FIGURE 2 - PHYSICAL DIMENSIONS (CONTINUED)**

**NOTES TO FIGURES 2(a) TO 2(c) INCLUSIVE**

1. Index area; a notch or dot shall be located adjacent to Pin 1 and shall be within the shaded area shown. For chip carrier packages the index shall be as defined in Figure 2(b).
2. Dimension Q shall be measured at the point of exit of the lead from the body.
3. Dimension Q shall be measured from the seating plane to the base plane.
4. This dimension allows for off-centre lids, meniscus and glass overrun.
5. The true position pin or terminal spacing is 1.27mm between centrelines. Each pin or terminal centreline shall be located within  $\pm 0.13\text{mm}$  of its true longitudinal position relative to Pins 1 and the highest pin number.
6. The true position pin spacing is 2.54mm between centrelines. Each pin centreline shall be located within  $\pm 0.25\text{mm}$  of its true longitudinal position relative to Pins 1 and the highest pin number.
7. Applies to all 4 corners.
8. All leads or terminals.
9. 18 spaces for flat and dual-in-line packages.  
16 spaces for chip carrier packages.
10. Lead centre when  $\alpha$  is  $0^\circ$ .
11. Index corner only - 2 dimensions.
12. 3 non-index corners - 6 dimensions.
13. 4 Places.
14. 16 Places.



**FIGURE 3(a) - PIN ASSIGNMENT**



**FIGURE 3(b) - TRUTH TABLE**

MODE	INPUTS								I/O PORTS								OUTPUTS	
	CLR	S1	S0	OUTPUT CONTROL		CLK	SL	SR	A/QA	B/QB	C/QC	D/QD	E/QE	F/QF	G/QG	H/QH	QA'	QH'
				G1	G2													
Clear	L	X	L	L	L	X	X	X	L	L	L	L	L	L	L	L	L	L
	L	L	X	L	L	X	X	X	L	L	L	L	L	L	L	L	L	L
	L	H	H	X	X	X	X	X	X	X	X	X	X	X	X	X	L	L
Hold	H	L	L	L	L	X	X	X	QA0	QB0	QC0	QD0	QE0	QF0	QG0	QH0	QA0	QH0
	H	X	X	L	L	L	X	X	QA0	QB0	QC0	QD0	QE0	QF0	QG0	QH0	QA0	QH0
Shift Right	H	L	H	L	L	↑	X	H	H	QA <sub>n</sub>	QB <sub>n</sub>	QC <sub>n</sub>	QD <sub>n</sub>	QE <sub>n</sub>	QF <sub>n</sub>	QG <sub>n</sub>	H	QH <sub>n</sub>
	H	L	H	L	L	↑	X	L	L	QA <sub>n</sub>	QB <sub>n</sub>	QC <sub>n</sub>	QD <sub>n</sub>	QE <sub>n</sub>	QF <sub>n</sub>	QG <sub>n</sub>	L	QH <sub>n</sub>
Shift Left	H	H	L	L	L	↑	H	X	QB <sub>n</sub>	QC <sub>n</sub>	QD <sub>n</sub>	QE <sub>n</sub>	QF <sub>n</sub>	QG <sub>n</sub>	QH <sub>n</sub>	H	QB <sub>n</sub>	H
	H	H	L	L	L	↑	L	X	QB <sub>n</sub>	QC <sub>n</sub>	QD <sub>n</sub>	QE <sub>n</sub>	QF <sub>n</sub>	QG <sub>n</sub>	QH <sub>n</sub>	L	QB <sub>n</sub>	L
Load	H	H	H	X	X	↑	X	X	a	b	c	d	e	f	g	h	a	h

**NOTES**

- When one or both output controls are high, the eight input/output terminals are disabled to the high impedance state; however, sequential operation or clearing of the register is not affected.
- Logic Level Definitions: L = Low Level, H = High Level, X = Irrelevant.
- ↑ = Transition from Low to High Level



FIGURE 3(c) - CIRCUIT SCHEMATIC

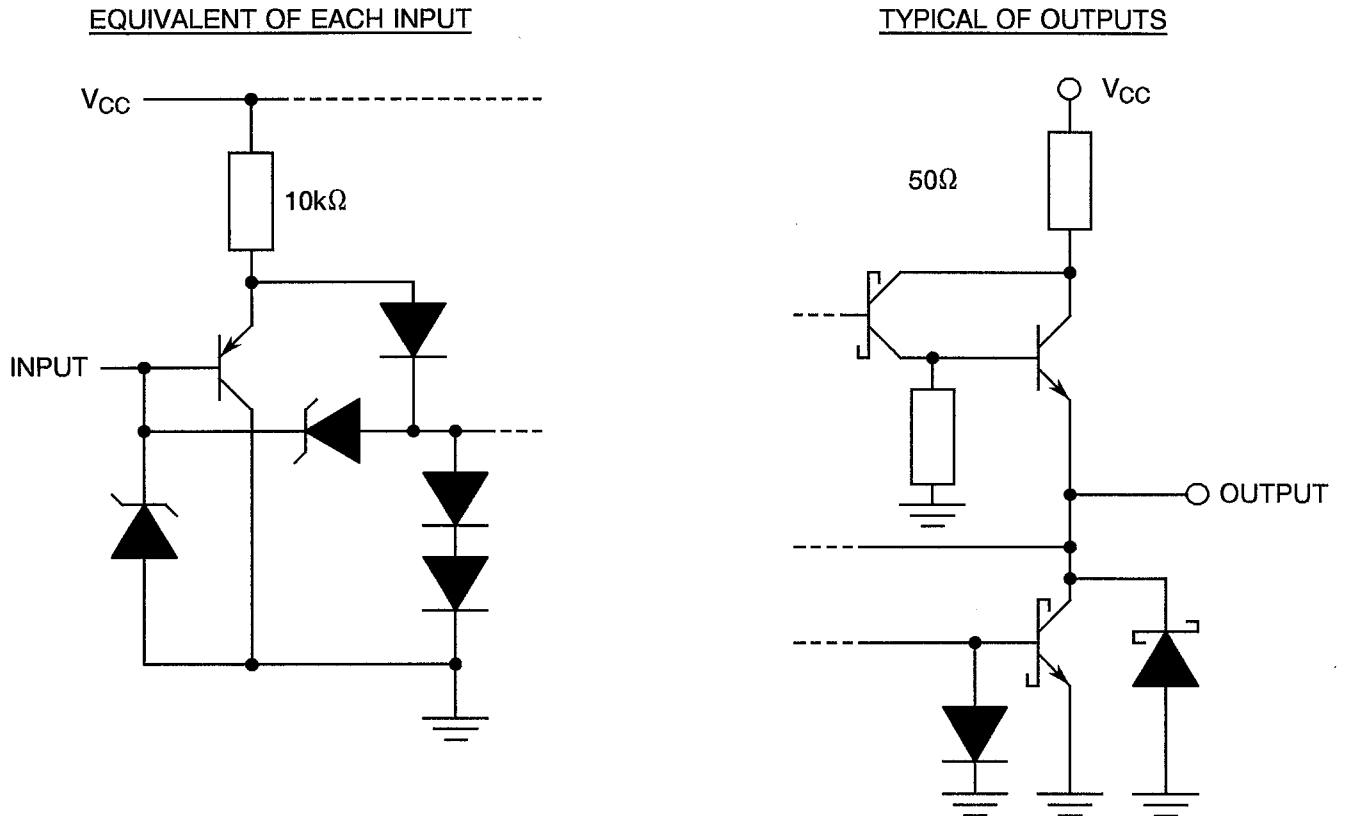
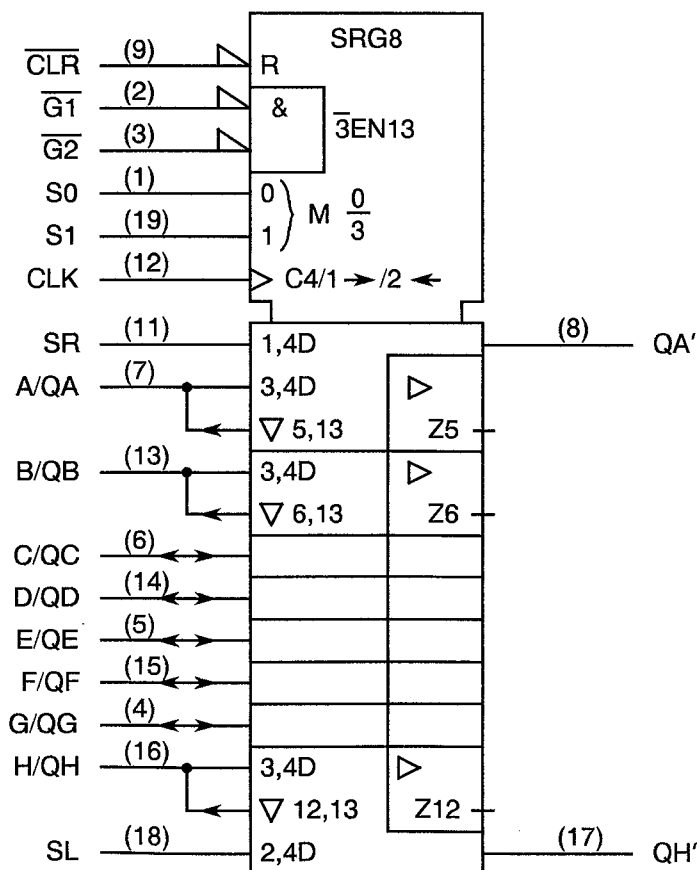


FIGURE 3(d) - FUNCTIONAL DIAGRAM



**2. APPLICABLE DOCUMENTS**

The following documents form part of this specification and shall be read in conjunction with it:-

- (a) ESA/SCC Generic Specification No. 9000 for Integrated Circuits.
- (b) MIL-STD-883, Test Methods and Procedures for Micro-electronics.

**3. TERMS, DEFINITIONS, ABBREVIATIONS, SYMBOLS AND UNITS**

For the purpose of this specification, the terms, definitions, abbreviations, symbols and units specified in ESA/SCC Basic Specification No. 21300 shall apply. In addition, the following abbreviations are used:-

- IOS/2 - One half of the true output short circuit current.
- IOZH - Off state, output current high.
- IOZL - Off state, output current low.
- ICCZ - Supply current, outputs disabled.

**4. REQUIREMENTS****4.1 GENERAL**

The complete requirements for procurement of the integrated circuits specified herein shall be as stated in this specification and ESA/SCC Generic Specification No. 9000 for Integrated Circuits. Deviations from the Generic Specification, applicable to this specification only, are listed in Para. 4.2.

Deviations from the applicable Generic Specification and this Detail Specification, formally agreed with specific Manufacturers on the basis that the alternative requirements are equivalent to the ESA/SCC requirements and do not affect the components' reliability, are listed in the appendices attached to this specification.

**4.2 DEVIATIONS FROM GENERIC SPECIFICATION****4.2.1 Deviations from Special In-process Controls**

None.

**4.2.2 Deviations from Final Production Tests (Chart II)**

None.

**4.2.3 Deviations from Burn-in Tests (Chart III)**

- (a) Para. 7.1.1(a), "High Temperature Reverse Bias" tests and subsequent electrical measurements related to this test shall be omitted.
- (b) Para. 9.9.2, "Electrical Measurements at High and Low Temperatures": Only a test result summary, based on go-no-go tests and presented in histogram form is required.

**4.2.4 Deviations from Qualification Tests (Chart IV)**

None.



#### 4.2.5 Deviations from Lot Acceptance Tests (Chart V)

None.

### 4.3 MECHANICAL REQUIREMENTS

#### 4.3.1 Dimension Check

The dimensions of the integrated circuits specified herein shall be checked. They shall conform to those shown in Figure 2.

#### 4.3.2 Weight

The maximum weight of the integrated circuits specified herein shall be 0.9 grammes for the flat package, 0.6 grammes for the chip carrier package and 3.2 grammes for the dual-in-line package.

### 4.4 MATERIALS AND FINISHES

The materials and finishes shall be as specified herein. Where a definite material is not specified, a material which will enable the integrated circuits specified herein to meet the performance requirements of this specification shall be used. Acceptance or approval of any constituent material does not guarantee acceptance of the finished product.

#### 4.4.1 Case

The case shall be hermetically sealed and have a metal body with hard glass seals or a ceramic body and the lids shall be welded, brazed, preform-soldered or glass frit-sealed.

#### 4.4.2 Lead Material and Finish

For dual-in-line and flat packages, the material shall be either Type 'D' or Type 'G' with either Type '4' or Type '7' finish in accordance with the requirements of ESA/SCC Basic Specification No. 23500. For chip carrier packages, the finish shall be either Type '4' or Type '7' in accordance with the requirements of ESA/SCC Basic Specification No. 23500. (See Table 1(a) for Type Variants).

### 4.5 MARKING

#### 4.5.1 General

The marking of all components delivered to this specification shall be in accordance with the requirements of ESA/SCC Basic Specification No. 21700. Each component shall be marked in respect of:-

- (a) Lead Identification.
- (b) The SCC Component Number.
- (c) Traceability Information.

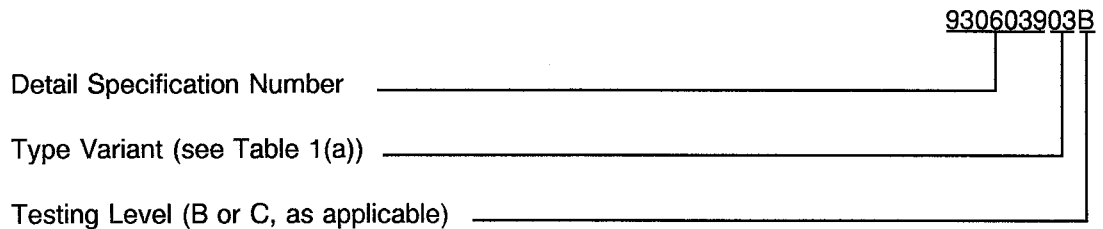
#### 4.5.2 Lead Identification

For dual-in-line and flat packages, an index shall be located at the top of the package in the position defined in Note 1 to Figure 2 or, alternatively, a tab may be used to identify Pin No. 1. The pin numbering must be read with the index or tab on the left-hand side. For chip carrier packages, the index shall be as defined by Figure 2(b).



4.5.3 The SCC Component Number

Each component shall bear the SCC Component Number which shall be constituted and marked as follows:



4.5.4 Traceability Information

Each component shall be marked in respect of traceability information in accordance with the requirements of ESA/SCC Basic Specification No. 21700.

4.6 ELECTRICAL MEASUREMENTS

4.6.1 Electrical Measurements at Room Temperature

The parameters to be measured in respect of electrical characteristics are scheduled in Table 2. Unless otherwise specified, the measurements shall be performed at  $T_{amb} = +22 \pm 3$  °C.

4.6.2 Electrical Measurements at High and Low Temperatures

The parameters to be measured at high and low temperatures are scheduled in Table 3. The measurements shall be performed at  $T_{amb} = +125(+0-5)$  °C and  $-55(+5-0)$  °C respectively.

4.6.3 Circuits for Electrical Measurements

Circuits for use in performing electrical measurements listed in Tables 2 and 3 of this specification are shown in Figure 4.

4.7 BURN-IN TESTS

4.7.1 Parameter Drift Values

The parameter drift values applicable to burn-in are specified in Table 4 of this specification. Unless otherwise stated, measurements shall be performed at  $T_{amb} = +22 \pm 3$  °C. The parameter drift values ( $\Delta$ ) applicable to the parameters scheduled, shall not be exceeded. In addition to these drift value requirements, the appropriate limit value specified for a given parameter in Table 2 shall not be exceeded.

4.7.2 Conditions for Power Burn-in

The requirements for power burn-in are specified in Section 7 of ESA/SCC Generic Specification No. 9000. The conditions for power burn-in shall be as specified in Table 5 of this specification.

4.7.3 Electrical Circuits for Power Burn-in

Circuits for use in performing the power burn-in tests are shown in Figure 5 of this specification.



**TABLE 2 - ELECTRICAL MEASUREMENTS AT ROOM TEMPERATURE - d.c. PARAMETERS**

NO.	CHARACTERISTICS	SYMBOL	TEST METHOD MIL-STD 883	TEST FIG.	TEST CONDITIONS (PINS UNDER TEST)	LIMITS		UNIT
						MIN	MAX	
1	Functional Test	-	-	3(b)	Verify Truth Table with Load. Note 1	-	-	-
2 to 17	Input Current High Level 1	$I_{IH1}$	3010	4(a)	$V_{CC} = 5.5V, V_{IN} = 2.7V$ (Pins 1-2-3-4-5-6-7-9-11-12-13-14-15-16-18-19)	-	20	$\mu A$
18 to 25	Input Current High Level 2 A through H (Max. Input Voltage)	$I_{IH2}$	3010	4(a)	$V_{CC} = 5.5V, V_{IN} = 5.5V$ (Pins 4-5-6-7-13-14-15-16)	-	100	$\mu A$
26 to 33	Input Current High Level 3 $\overline{S1}, \overline{S0}, \overline{G1}, \overline{G2},$ $\overline{CLR}, \overline{SR}, \overline{CLK}, \overline{SL}$ (Max. Input Voltage)	$I_{IH3}$	3010	4(a)	$V_{CC} = 5.5V, V_{IN} = 7.0V$ (Pins 1-2-3-9-11-12-18-19)	-	100	$\mu A$
34 to 49	Input Clamp Voltage	$V_{IC}$	3008	4(b)	$V_{CC} = 4.5V, I_{IN} = -18mA$ Note 2 (Pins 1-2-3-4-5-6-7-9-11-12-13-14-15-16-18-19)	-	-1.5	V
50 to 65	Input Current Low Level	$I_{IL}$	3009	4(c)	$V_{CC} = 5.5V, V_{IL} = 0.4V$ Note 3 (Pins 1-2-3-4-5-6-7-9-11-12-13-14-15-16-18-19)	-	-200	$\mu A$
66 to 73	Output Voltage Low Level 1 QA through QH	$V_{OL1}$	3007	4(d)	$V_{CC} = 4.5V, V_{IH} = 2.0V$ $V_{IL} = 0.7V, I_{OL} = 12mA$ (Pins 4-5-6-7-13-14-15-16)	-	0.4	V
74 to 75	Output Voltage Low Level 2 QA' and QH'	$V_{OL2}$	3007	4(d)	$V_{CC} = 4.5V, V_{IH} = 2.0V$ $V_{IL} = 0.7V, I_{OL} = 4.0mA$ (Pins 8-17)	-	0.4	V
76 to 83	Output Voltage High Level 1 QA through QH	$V_{OH1}$	3006	4(e)	$V_{CC} = 4.5V, V_{IH} = 2.0V$ $V_{IL} = 0.7V, I_{OH} = -1.0mA$ (Pins 4-5-6-7-13-14-15-16)	2.4	-	V
84 to 93	Output Voltage High Level 2	$V_{OH2}$	3006	4(e)	$V_{CC} = 4.5V, V_{IH} = 2.0V$ $V_{IL} = 0.7V, I_{OH} = -400\mu A$ (Pins 4-5-6-7-8-13-14-15-16-17)	2.5	-	V

**NOTES:** See Page 21.





**TABLE 2 - ELECTRICAL MEASUREMENTS AT ROOM TEMPERATURE - d.c. PARAMETERS (CONT'D)**

NO.	CHARACTERISTICS	SYMBOL	TEST METHOD MIL-STD 883	TEST FIG.	TEST CONDITIONS (PINS UNDER TEST)	LIMITS		UNIT
						MIN	MAX	
94 to 101	Output Voltage High Level 3	$V_{OH3}$	3006	4(e)	$V_{CC} = 4.5V$ , $V_{IH} = 2.0V$ $V_{IL} = 0.7V$ , $I_{OH} = -400\mu A$ (Pins 4-5-6-7-8-13-14-15-16-17)	3.5	-	V
102 to 109	One Half of the True Output Short Circuit Current QA through QH	$I_{OS1/2}$	3011	4(f)	$V_{CC} = 5.5V$ , $V_{OUT} = 2.25V$ Note 4 (Pins 4-5-6-7-13-14-15-16)	-30	-112	mA
110 to 111	One Half of the True Output Short Circuit Current QA' and QH'	$I_{OS2/2}$	3011	4(f)	$V_{CC} = 5.5V$ , $V_{OUT} = 2.25V$ Note 4 (Pins 8-17)	-15	-70	mA
112	Supply Current Outputs High	$I_{CCH}$	3005	4(g)	$V_{CC} = 5.5V$ Note 5 (Pin 20)	-	28	mA
113	Supply Current Outputs Low	$I_{CCL}$	3005	4(g)	$V_{CC} = 5.5V$ Note 5 (Pin 20)	-	38	mA
114	Supply Current Outputs Disabled	$I_{CCZ}$	3005	4(g)	$V_{CC} = 5.5V$ Note 5 (Pin 20)	-	40	mA

**NOTES:** See Page 21.



**TABLE 2 - ELECTRICAL MEASUREMENTS AT ROOM TEMPERATURE - a.c. PARAMETERS**

NO.	CHARACTERISTICS	SYMBOL	TEST METHOD MIL-STD 883	TEST FIG.	TEST CONDITIONS (PINS UNDER TEST) (NOTE 6)	LIMITS		UNIT
						MIN	MAX	
115 to 130	Propagation Delay Low to High, from Clock to I/O Ports	$t_{PLH1}$	3003	4(h)	$V_{CC} = 4.5$ and $5.5V$ $C_L = 50pF$ $R_1 = R_2 = 500\Omega$ <u>Pins</u> 12 to 4    12 to 13 12 to 5    12 to 14 12 to 6    12 to 15 12 to 7    12 to 16	4.0	15	ns
131 to 134	Propagation Delay Low to High, from Clock to QA' or QH'	$t_{PLH2}$	3003	4(h)	$V_{CC} = 4.5$ and $5.5V$ $C_L = 50pF$ $R_1 = R_2 = 500\Omega$ <u>Pins</u> 12 to 8    12 to 17	5.0	20	ns
135 to 150	Propagation Delay High to Low, from Clock to I/O Ports	$t_{PHL1}$	3003	4(h)	$V_{CC} = 4.5$ and $5.5V$ $C_L = 50pF$ $R_1 = R_2 = 500\Omega$ <u>Pins</u> 12 to 4    12 to 13 12 to 5    12 to 14 12 to 6    12 to 15 12 to 7    12 to 16	7.0	25	ns
151 to 154	Propagation Delay High to Low, from Clock to QA' or QH'	$t_{PHL2}$	3003	4(h)	$V_{CC} = 4.5$ and $5.5V$ $C_L = 50pF$ $R_1 = R_2 = 500\Omega$ <u>Pins</u> 12 to 8    12 to 17	8.0	21	ns
155 to 174	Propagation Delay High to Low, from CLR to I/O Ports	$t_{PHL3}$	3003	4(h)	$V_{CC} = 4.5$ and $5.5V$ $C_L = 50pF$ $R_1 = R_2 = 500\Omega$ <u>Pins</u> 9 to 4    9 to 13 9 to 5    9 to 14 9 to 6    9 to 15 9 to 7    9 to 16 9 to 8    9 to 17	6.0	29	ns

**NOTES:** See Page 21.



**TABLE 2 - ELECTRICAL MEASUREMENTS AT ROOM TEMPERATURE - a.c. PARAMETERS (CONT'D)**

NO.	CHARACTERISTICS	SYMBOL	TEST METHOD MIL-STD 883	TEST FIG.	TEST CONDITIONS (PINS UNDER TEST) (NOTE 6)	LIMITS		UNIT
						MIN	MAX	
175 to 206	Output Enable Time to <u>High Level</u> from <u>G1</u> or <u>G2</u> to I/O Ports	t <sub>PZH1</sub>	3003	4(h)	V <sub>CC</sub> = 4.5 and 5.5V C <sub>L</sub> = 50pF R <sub>1</sub> = R <sub>2</sub> = 500Ω <u>Pins</u> 2 to 4      3 to 4 2 to 5      3 to 5 2 to 6      3 to 6 2 to 7      3 to 7 2 to 13     3 to 13 2 to 14     3 to 14 2 to 15     3 to 15 2 to 16     3 to 16	6.0	21	ns
207 to 238	Output Enable Time to <u>Low Level</u> from <u>G1</u> or <u>G2</u> to I/O Ports	t <sub>PZL1</sub>	3003	4(h)	V <sub>CC</sub> = 4.5 and 5.5V C <sub>L</sub> = 50pF R <sub>1</sub> = R <sub>2</sub> = 500Ω <u>Pins</u> 2 to 4      3 to 4 2 to 5      3 to 5 2 to 6      3 to 6 2 to 7      3 to 7 2 to 13     3 to 13 2 to 14     3 to 14 2 to 15     3 to 15 2 to 16     3 to 16	8.0	26	ns
239 to 270	Output Enable Time to <u>High Level</u> from <u>S0</u> or <u>S1</u> to I/O Ports	t <sub>PZH2</sub>	3003	4(h)	V <sub>CC</sub> = 4.5 and 5.5V C <sub>L</sub> = 50pF R <sub>1</sub> = R <sub>2</sub> = 500Ω <u>Pins</u> 1 to 4      19 to 4 1 to 5      19 to 5 1 to 6      19 to 6 1 to 7      19 to 7 1 to 13     19 to 13 1 to 14     19 to 14 1 to 15     19 to 15 1 to 16     19 to 16	7.0	21	ns

**NOTES:** See Page 21.

**TABLE 2 - ELECTRICAL MEASUREMENTS AT ROOM TEMPERATURE - a.c. PARAMETERS (CONT'D)**

NO.	CHARACTERISTICS	SYMBOL	TEST METHOD MIL-STD 883	TEST FIG.	TEST CONDITIONS (PINS UNDER TEST) (NOTE 6)	LIMITS		UNIT
						MIN	MAX	
271 to 302	Output Enable Time to Low Level from S0 or S1 to I/O Ports	t <sub>PZL2</sub>	3003	4(h)	V <sub>CC</sub> = 4.5 and 5.5V C <sub>L</sub> = 50pF R <sub>1</sub> = R <sub>2</sub> = 500Ω <u>Pins</u> 1 to 4      19 to 4 1 to 5      19 to 5 1 to 6      19 to 6 1 to 7      19 to 7 1 to 13     19 to 13 1 to 14     19 to 14 1 to 15     19 to 15 1 to 16     19 to 16	8.0	26	ns
303 to 334	Output Disable Time to High Level from G1 or G2 to I/O Ports	t <sub>PHZ1</sub>	3003	4(h)	V <sub>CC</sub> = 4.5 and 5.5V C <sub>L</sub> = 50pF R <sub>1</sub> = R <sub>2</sub> = 500Ω <u>Pins</u> 2 to 4      3 to 4 2 to 5      3 to 5 2 to 6      3 to 6 2 to 7      3 to 7 2 to 13     3 to 13 2 to 14     3 to 14 2 to 15     3 to 15 2 to 16     3 to 16	1.0	10	ns
335 to 366	Output Disable Time to Low Level from G1 or G2 to I/O Ports	t <sub>PLZ1</sub>	3003	4(h)	V <sub>CC</sub> = 4.5 and 5.5V C <sub>L</sub> = 50pF R <sub>1</sub> = R <sub>2</sub> = 500Ω <u>Pins</u> 2 to 4      3 to 4 2 to 5      3 to 5 2 to 6      3 to 6 2 to 7      3 to 7 2 to 13     3 to 13 2 to 14     3 to 14 2 to 15     3 to 15 2 to 16     3 to 16	5.0	23	ns

**NOTES:** See Page 21.

**TABLE 2 - ELECTRICAL MEASUREMENTS AT ROOM TEMPERATURE - a.c. PARAMETERS (CONT'D)**

NO.	CHARACTERISTICS	SYMBOL	TEST METHOD MIL-STD 883	TEST FIG.	TEST CONDITIONS (PINS UNDER TEST) (NOTE 6)	LIMITS		UNIT
						MIN	MAX	
367 to 398	Output Disable Time to High Level from S0 or S1 to I/O Ports	$t_{PHZ2}$	3003	4(h)	$V_{CC} = 4.5$ and $5.5V$ $C_L = 50pF$ $R_1 = R_2 = 500\Omega$ Pins 1 to 4      19 to 4 1 to 5      19 to 5 1 to 6      19 to 6 1 to 7      19 to 7 1 to 13     19 to 13 1 to 14     19 to 14 1 to 15     19 to 15 1 to 16     19 to 16	3.0	18	ns
399 to 430	Output Disable Time to Low Level from S0 or S1 to I/O Ports	$t_{PLZ2}$	3003	4(h)	$V_{CC} = 4.5$ and $5.5V$ $C_L = 50pF$ $R_1 = R_2 = 500\Omega$ Pins 1 to 4      19 to 4 1 to 5      19 to 5 1 to 6      19 to 6 1 to 7      19 to 7 1 to 13     19 to 13 1 to 14     19 to 14 1 to 15     19 to 15 1 to 16     19 to 16	8.0	30	ns
431 to 432	Maximum Clock Frequency	$f_{max}$	-	4(h)	$V_{CC} = 4.5$ and $5.5V$ $C_L = 50pF$ $R_1 = R_2 = 500\Omega$ Note 7 (Pin 12)	25	-	MHz

**NOTES**

- Go-no-go test with  $V_{IL} = 0.3V$ ,  $V_{IH} = 3.0V$ , trip point 1.5V.
- All inputs and outputs not under test shall be open.
- For I/O Ports, the parameters include the Off-State Output Currents ( $I_{OZH}$ ,  $I_{OZL}$ ).
- No more than 1 output should be tested at a time.
- For  $I_{CCH}$  :  $\overline{S1}$ ,  $\overline{G1}$ ,  $\overline{G2}$  Grounded,  $\overline{CLR}$ , S0, SR at 4.5V, all Data Outputs High and Clock transition Low to High.  
 For  $I_{CCL}$  :  $\overline{G1}$ ,  $\overline{G2}$ ,  $\overline{CLR}$ , S0 and all Data Inputs Grounded.  
 For  $I_{CCZ}$  :  $\overline{G1}$  at 4.5V.
- Propagation delay measurements shall be performed as a go-no-go test on a 100% basis. Read-and-record measurements shall be performed on an LTPD7 sample basis following the Chart III Burn-in Test.
- This parameter shall be tested as go-no-go on a 100% basis.

**TABLE 3 - ELECTRICAL MEASUREMENTS AT HIGH AND LOW TEMPERATURES,  
+125(+0-5) °C AND -55(+5-0) °C**

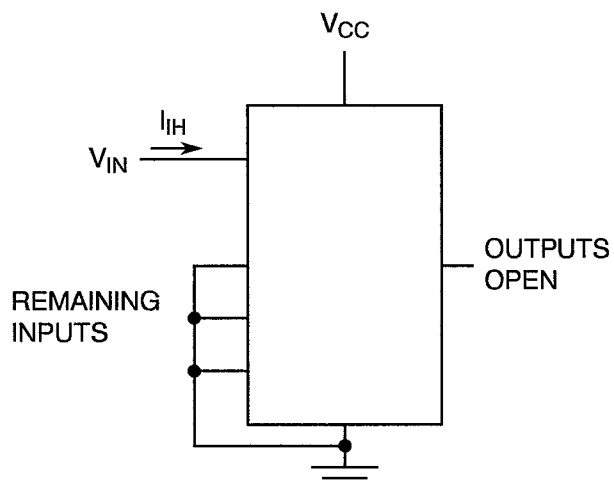
NO.	CHARACTERISTICS	SYMBOL	TEST METHOD MIL-STD 883	TEST FIG.	TEST CONDITIONS (PINS UNDER TEST)	LIMITS		UNIT
						MIN	MAX	
1	Functional Test	-	-	3(b)	Verify Truth Table with Load. Note 1	-	-	-
2 to 17	Input Current High Level 1	$I_{IH1}$	3010	4(a)	$V_{CC} = 5.5V, V_{IN} = 2.7V$ (Pins 1-2-3-4-5-6-7-9-11-12-13-14-15-16-18-19)	-	20	$\mu A$
18 to 25	Input Current High Level 2 A through H (Max. Input Voltage)	$I_{IH2}$	3010	4(a)	$V_{CC} = 5.5V, V_{IN} = 5.5V$ (Pins 4-5-6-7-13-14-15-16)	-	100	$\mu A$
26 to 33	Input Current High Level 3 $\overline{S1}, \overline{S0}, \overline{G1}, \overline{G2},$ $\overline{CLR}, \overline{SR}, \overline{CLK}, \overline{SL}$ (Max. Input Voltage)	$I_{IH3}$	3010	4(a)	$V_{CC} = 5.5V, V_{IN} = 7.0V$ (Pins 1-2-3-9-11-12-18-19)	-	100	$\mu A$
34 to 49	Input Clamp Voltage	$V_{IC}$	3008	4(b)	$V_{CC} = 4.5V, I_{IN} = -18mA$ Note 2 (Pins 1-2-3-4-5-6-7-9-11-12-13-14-15-16-18-19)	-	-1.5	V
50 to 65	Input Current Low Level	$I_{IL}$	3009	4(c)	$V_{CC} = 5.5V, V_{IL} = 0.4V$ Note 3 (Pins 1-2-3-4-5-6-7-9-11-12-13-14-15-16-18-19)	-	-200	$\mu A$
66 to 73	Output Voltage Low Level 1 QA through QH	$V_{OL1}$	3007	4(d)	$V_{CC} = 4.5V, V_{IH} = 2.0V$ $V_{IL} = 0.7V, I_{OL} = 12mA$ (Pins 4-5-6-7-13-14-15-16)	-	0.4	V
74 to 75	Output Voltage Low Level 2 QA' and QH'	$V_{OL2}$	3007	4(d)	$V_{CC} = 4.5V, V_{IH} = 2.0V$ $V_{IL} = 0.7V, I_{OL} = 4.0mA$ (Pins 8-17)	-	0.4	V
76 to 83	Output Voltage High Level 1 QA through QH	$V_{OH1}$	3006	4(e)	$V_{CC} = 4.5V, V_{IH} = 2.0V$ $V_{IL} = 0.7V, I_{OH} = -1.0mA$ (Pins 4-5-6-7-13-14-15-16)	2.4	-	V
84 to 93	Output Voltage High Level 2	$V_{OH2}$	3006	4(e)	$V_{CC} = 4.5V, V_{IH} = 2.0V$ $V_{IL} = 0.7V, I_{OH} = -400\mu A$ (Pins 4-5-6-7-8-13-14-15-16-17)	2.5	-	V

**NOTES:** See Page 21.

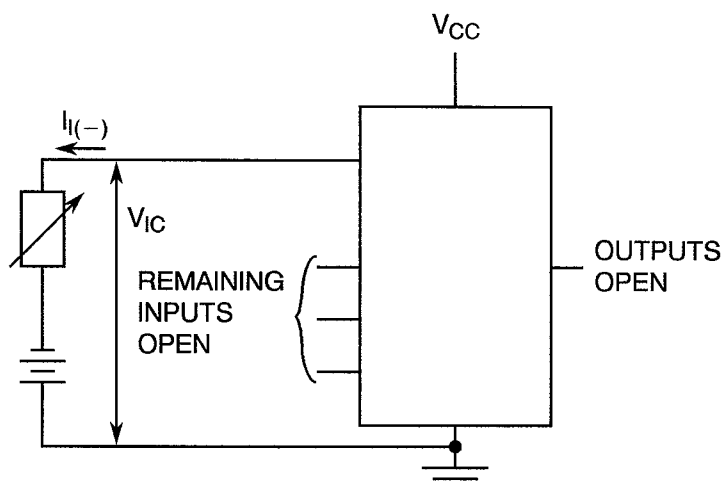
**TABLE 3 - ELECTRICAL MEASUREMENTS AT HIGH AND LOW TEMPERATURES,  
+ 125(+ 0 - 5) °C AND - 55(+ 5 - 0) °C (CONT'D)**

NO.	CHARACTERISTICS	SYMBOL	TEST METHOD MIL-STD 883	TEST FIG.	TEST CONDITIONS (PINS UNDER TEST)	LIMITS		UNIT
						MIN	MAX	
94 to 101	Output Voltage High Level 3	$V_{OH3}$	3006	4(e)	$V_{CC} = 4.5V$ , $V_{IH} = 2.0V$ $V_{IL} = 0.7V$ , $I_{OH} = -400\mu A$ (Pins 4-5-6-7-8-13-14-15-16-17)	3.5	-	V
102 to 109	One Half of the True Output Short Circuit Current QA through QH	$I_{OS1/2}$	3011	4(f)	$V_{CC} = 5.5V$ , $V_{OUT} = 2.25V$ Note 4 (Pins 4-5-6-7-13-14-15-16)	-30	-112	mA
110 to 111	One Half of the True to Output Short Circuit Current QA' and QH'	$I_{OS2/2}$	3011	4(f)	$V_{CC} = 5.5V$ , $V_{OUT} = 2.25V$ Note 4 (Pins 8-17)	-15	-70	mA
112	Supply Current Outputs High	$I_{CCH}$	3005	4(g)	$V_{CC} = 5.5V$ Note 5 (Pin 20)	-	28	mA
113	Supply Current Outputs Low	$I_{CCL}$	3005	4(g)	$V_{CC} = 5.5V$ Note 5 (Pin 20)	-	38	mA
114	Supply Current Outputs Disabled	$I_{CCZ}$	3005	4(g)	$V_{CC} = 5.5V$ Note 5 (Pin 20)	-	40	mA

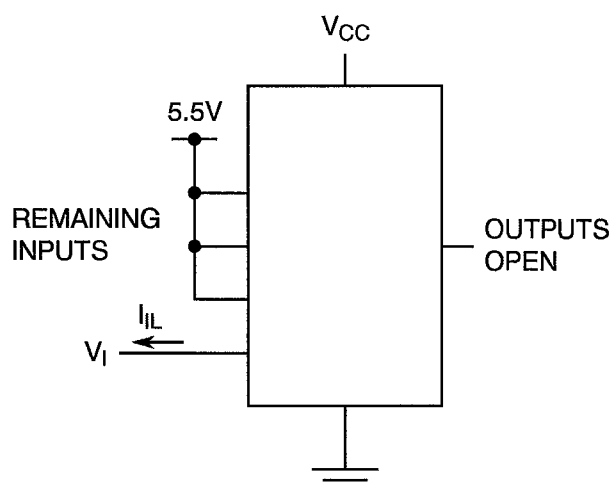
**NOTES:** See Page 21.

**FIGURE 4 - CIRCUITS FOR ELECTRICAL MEASUREMENTS**
**FIGURE 4(a) - INPUT CURRENT HIGH LEVEL**

**NOTES**

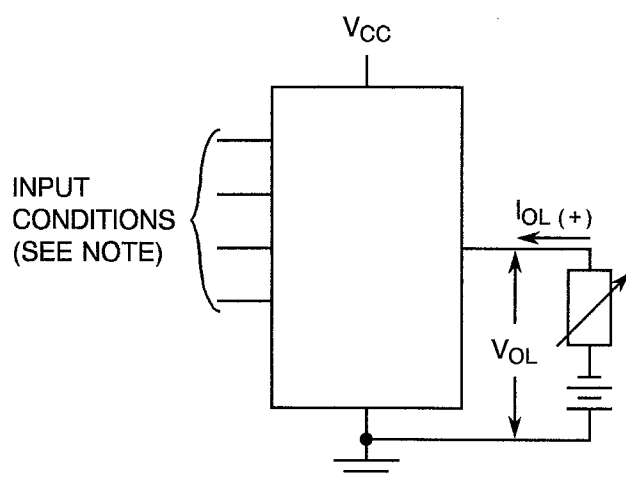
1. Each input to be tested separately.

**FIGURE 4(b) - INPUT CLAMP VOLTAGE**

**NOTES**

1. Each input to be tested separately.

**FIGURE 4(c) - LOW LEVEL INPUT CURRENT**

**NOTES**

1. Each input to be tested separately.

**FIGURE 4(d) - LOW LEVEL OUTPUT VOLTAGE**

**NOTES**

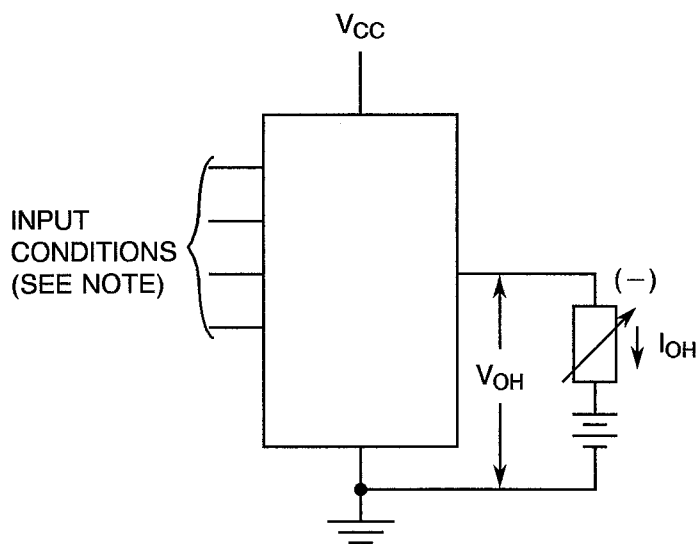
1. Test per Truth Table.





**FIGURE 4 - CIRCUITS FOR ELECTRICAL MEASUREMENTS (CONTINUED)**

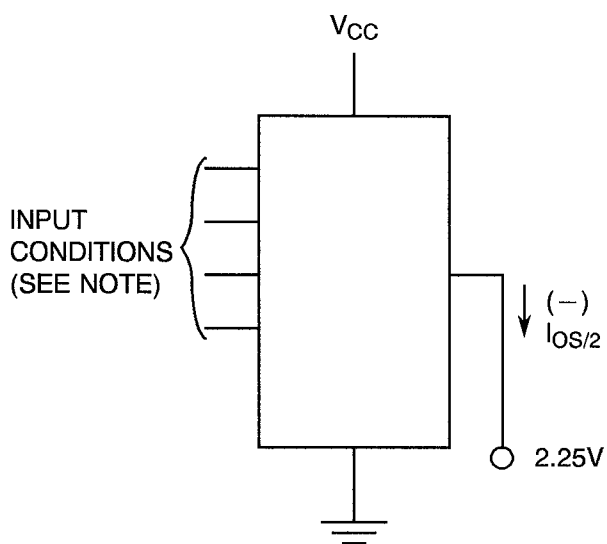
FIGURE 4(e) - HIGH LEVEL OUTPUT VOLTAGE



**NOTES**

1. Test per Truth Table.

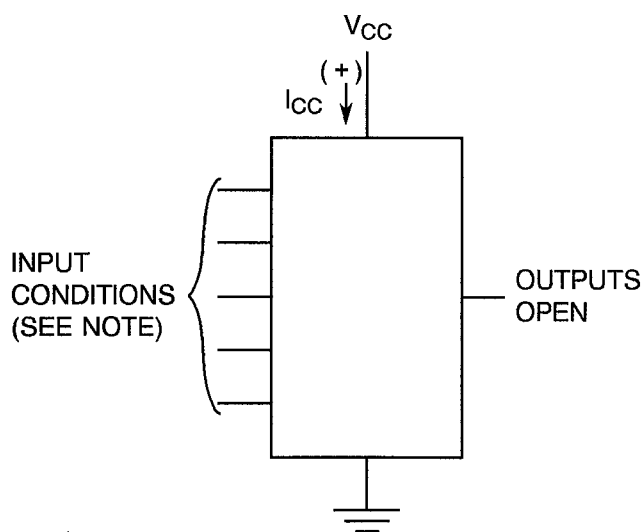
FIGURE 4(f) - ONE HALF SHORT CIRCUIT OUTPUT CURRENT



**NOTES**

1. No more than 1 output should be tested at a time.
2. Test per Truth Table.

FIGURE 4(g) - SUPPLY CURRENT



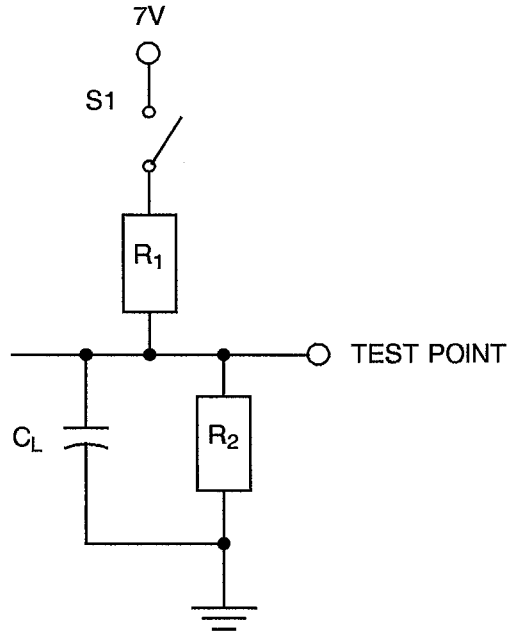
**NOTES**

1. See Note 5 on Page 21.

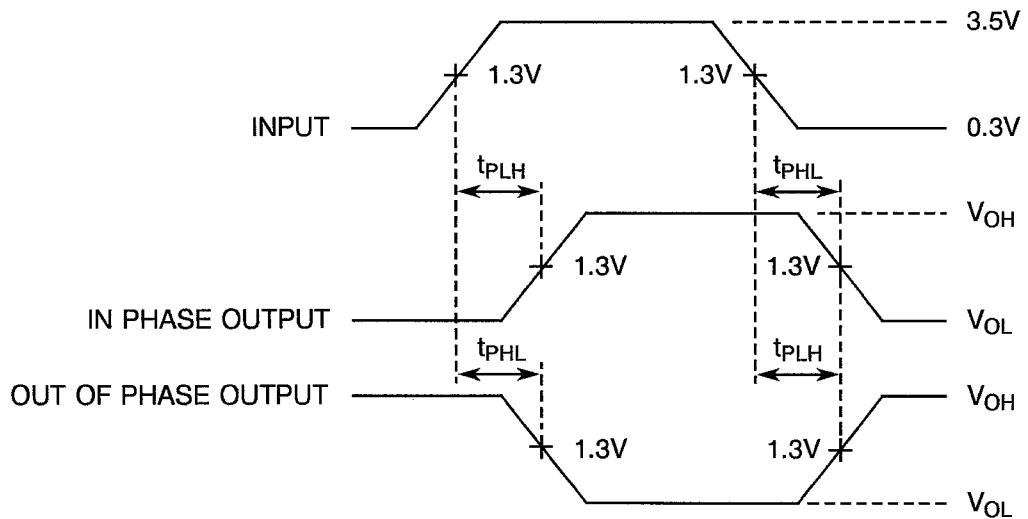


**FIGURE 4 - CIRCUITS FOR ELECTRICAL MEASUREMENTS (CONTINUED)**

FIGURE 4(h) - DYNAMIC TEST AND SWITCHING WAVEFORMS



VOLTAGE WAVEFORMS - PROPAGATION DELAY TIMES



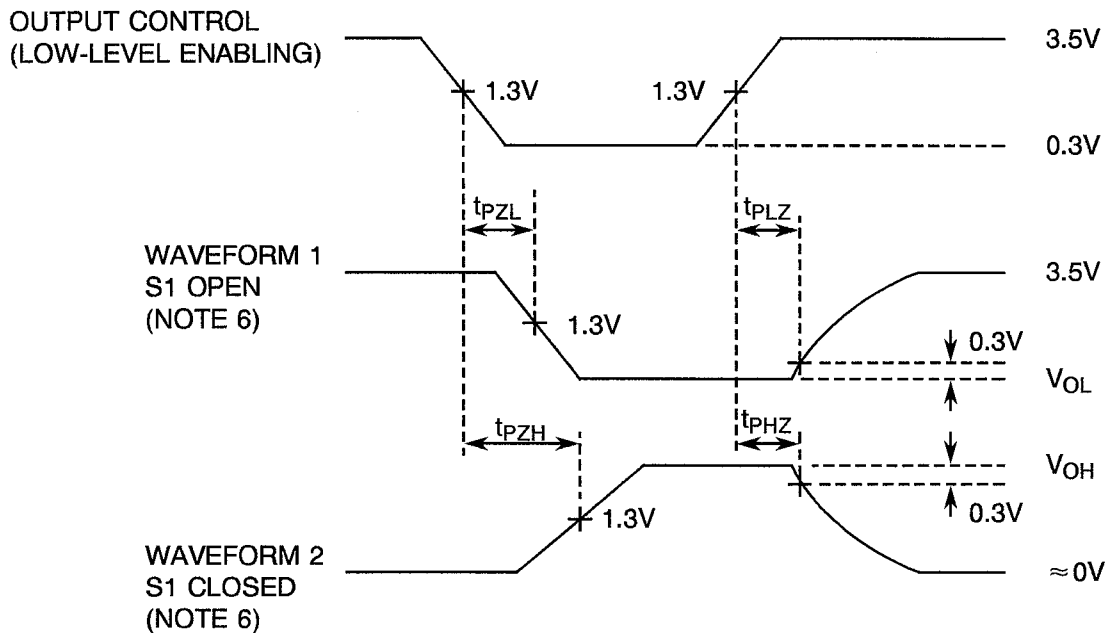
**NOTES:** See Note 5 on Page 27.



**FIGURE 4 - CIRCUITS FOR ELECTRICAL MEASUREMENTS (CONTINUED)**

**FIGURE 4(h) - DYNAMIC TEST AND SWITCHING WAVEFORMS (CONTINUED)**

**VOLTAGE WAVEFORMS - ENABLE AND DISABLE TIMES**



**NOTES**

1. The generator has the following characteristics:  $t_r = t_f = 2ns$ ,  $PRR = 1MHz$ ,  $Z_{out} = 50\Omega$ , Duty Cycle = 50%.
2.  $C_L = 50pF \pm 5\%$  including scope probe, wiring and stray capacitance without package in test fixture.
3. Each register tested separately.
4.  $R_1 = R_2 = 500\Omega \pm 5\%$ .
5. For measurement of Propagation Times, Switch S1 is open.
6. Waveform 1 is for an output with internal conditions such that the output is low except when disabled by the Output Control.

Waveform 2 is for an output with internal conditions such that the output is high except when disabled by the Output Control.

**TABLE 4 - PARAMETER DRIFT VALUES**

NO.	CHARACTERISTICS	SYMBOL	SPEC. AND/OR TEST METHOD	TEST CONDITIONS	CHANGE LIMITS ( $\Delta$ )	UNIT
2 to 17	Input Current High Level 1	$I_{IH1}$	As per Table 2	As per Table 2	$\pm 20$ or (1) $\pm 0.5$	% $\mu A$
50 to 65	Input Current Low Level	$I_{IL}$	As per Table 2	As per Table 2	$\pm 10$	$\mu A$
66 to 73	Output Voltage Low Level 1 QA through QH	$V_{OL1}$	As per Table 2	As per Table 2	$\pm 60$	mV
74 to 75	Output Voltage Low Level 2 QA' and QH'	$V_{OL2}$	As per Table 2	As per Table 2	$\pm 60$	mV
76 to 83	Output Voltage High Level 1 QA through QH	$V_{OH1}$	As per Table 2	As per Table 2	$\pm 200$	mV
84 to 93	Output Voltage High Level 2	$V_{OH2}$	As per Table 2	As per Table 2	$\pm 200$	mV
94 to 101	Output Voltage High Level 3	$V_{OH3}$	As per Table 2	As per Table 2	$\pm 200$	mV

**NOTES**

1. Whichever is greater referred to the initial value.

**TABLE 5 - CONDITIONS FOR POWER BURN-IN AND OPERATING LIFE TEST**

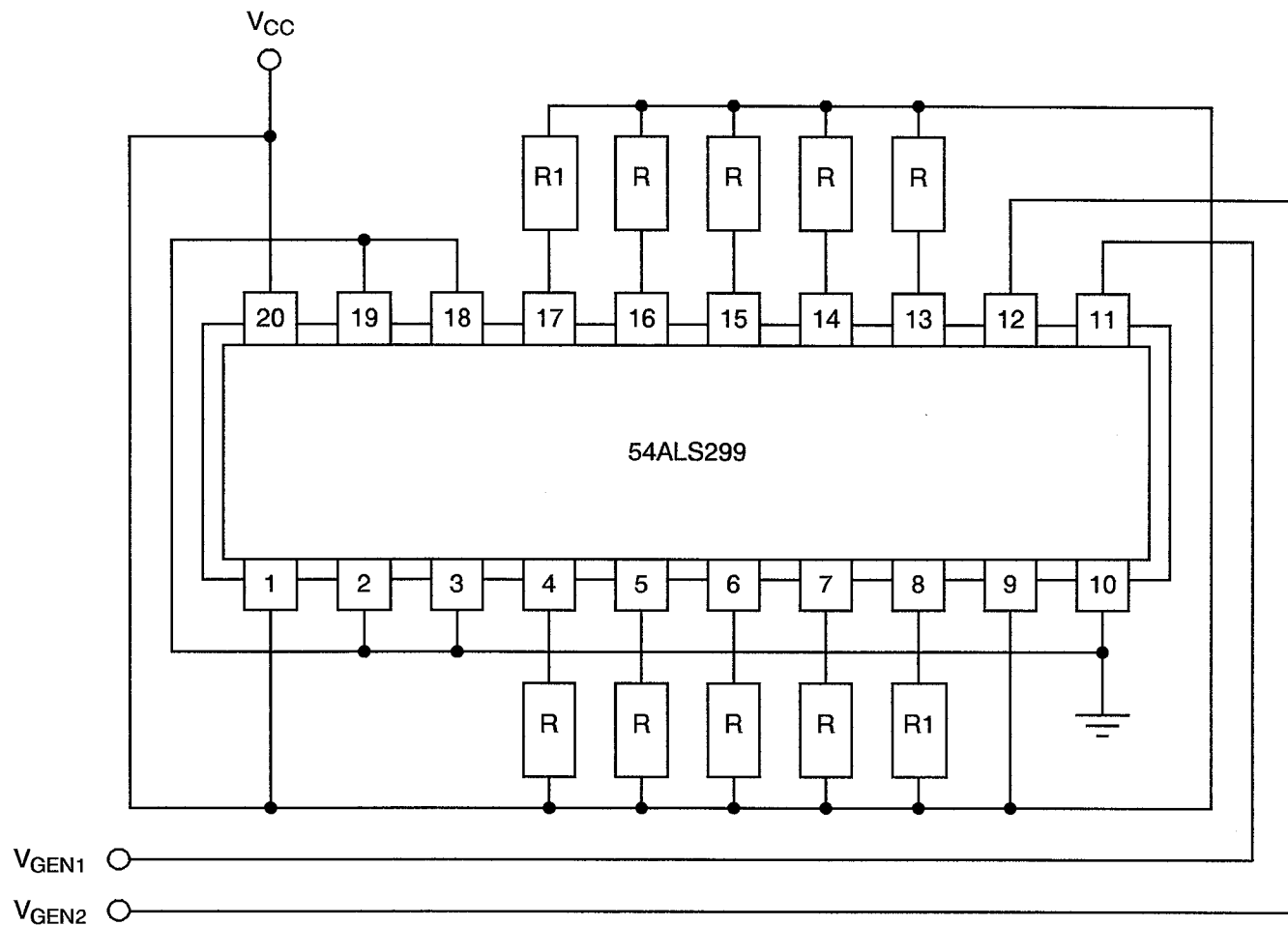
NO.	CHARACTERISTICS	SYMBOL	CONDITION	UNIT
1	Ambient Temperature	$T_{amb}$	+ 125(+ 0 - 5)	$^{\circ}C$
2	Power Supply Voltage	$V_{CC}$	+ 5(+ 0.5 - 0)	V
3	Pulse Voltage	$V_{GEN}$	0.5 max. to 3.0 min.	Vac
4	Frequency	f GEN1 GEN2	100 50 (See Note 1)	Hz
5	Fan-out	-	10	-
6	Rise Time	$t_r$	50 max.	$\mu s$
7	Fall Time	$t_f$	50 max.	$\mu s$
8	Duty Cycle	-	20 min.	%

**NOTES**

1. Tolerance  $\pm 10\%$ .



**FIGURE 5 - ELECTRICAL CIRCUIT FOR POWER BURN-IN AND OPERATING LIFE TEST**



**NOTES**

1.  $V_{GEN2} = V_{GEN1} \div 2$ .
2.  $R = 400\Omega$ .
3.  $R1 = 1.2k\Omega$ .



#### 4.8 ENVIRONMENTAL AND ENDURANCE TESTS (CHARTS IV AND V OF ESA/SCC GENERIC SPECIFICATION NO. 9000)

##### 4.8.1 Electrical Measurements on Completion of Environmental Tests

The parameters to be measured on completion of environmental tests are scheduled in Table 6. Unless otherwise stated, the measurements shall be performed at  $T_{amb} = +22 \pm 3$  °C.

##### 4.8.2 Electrical Measurements at Intermediate Points during Endurance Tests

The parameters to be measured at intermediate points during endurance tests are as scheduled in Table 6 of this specification. Unless otherwise stated, the measurements shall be performed at  $T_{amb} = +22 \pm 3$  °C.

##### 4.8.3 Electrical Measurements on Completion of Endurance Tests

The parameters to be measured on completion of endurance testing are as scheduled in Table 6 of this specification. Unless otherwise stated, the measurements shall be performed at  $T_{amb} = +22 \pm 3$  °C.

##### 4.8.4 Conditions for Operating Life Tests

The requirements for operating life testing are specified in Section 9 of ESA/SCC Generic Specification No. 9000. The conditions for operating life testing shall be as specified in Table 5 of this specification.

##### 4.8.5 Electrical Circuits for Operating Life Tests

Circuits for use in performing the operating life tests are shown in Figure 5.

##### 4.8.6 Conditions for High Temperature Storage Test

The requirements for the high temperature storage test are specified in ESA/SCC Generic Specification No. 9000. The conditions for high temperature storage shall be  $T_{amb} = +150(+0-5)$  °C.



**TABLE 6 - ELECTRICAL MEASUREMENTS ON COMPLETION OF ENVIRONMENTAL TESTS AND AT INTERMEDIATE POINTS AND ON COMPLETION OF ENDURANCE TESTS**

NO.	CHARACTERISTICS	SYMBOL	SPEC. AND/OR TEST METHOD	TEST CONDITIONS	CHANGE LIMITS		UNIT
					( $\Delta$ )	ABSOLUTE	
2 to 17	Input Current High Level 1	$I_{IH1}$	As per Table 2	As per Table 2	$\pm 1$	-	$\mu A$
18 to 25	Input Current High Level 2 A through H (Max. Input Voltage)	$I_{IH2}$	As per Table 2	As per Table 2	-	100	$\mu A$
26 to 33	Input Current High Level 3 S1, S0, $\overline{G1}$ , $\overline{G2}$ , $\overline{CLR}$ , SR, CLK, SL (Max. Input Voltage)	$I_{IH3}$	As per Table 2	As per Table 2	-	100	$\mu A$
50 to 65	Input Current Low Level	$I_{IL}$	As per Table 2	As per Table 2	$\pm 10$	-	$\mu A$
66 to 73	Output Voltage Low Level 1 QA through QH	$V_{OL1}$	As per Table 2	As per Table 2	$\pm 60$	-	mV
74 to 75	Output Voltage Low Level 2 QA' and QH'	$V_{OL2}$	As per Table 2	As per Table 2	$\pm 60$	-	mV
76 to 83	Output Voltage High Level 1 QA through QH	$V_{OH1}$	As per Table 2	As per Table 2	$\pm 200$	-	mV
84 to 93	Output Voltage High Level 2	$V_{OH2}$	As per Table 2	As per Table 2	$\pm 200$	-	mV
94 to 101	Output Voltage High Level 3	$V_{OH3}$	As per Table 2	As per Table 2	$\pm 200$	-	mV
112	Supply Current Outputs High	$I_{CCH}$	As per Table 2	As per Table 2	$\pm 20$	-	%
113	Supply Current Outputs Low	$I_{CCL}$	As per Table 2	As per Table 2	$\pm 20$	-	%
114	Supply Current Outputs Disabled	$I_{CCZ}$	As per Table 2	As per Table 2	$\pm 20$	-	%

**APPENDIX 'A'**

**AGREED DEVIATIONS FOR TEXAS INSTRUMENTS (F)**

ITEMS AFFECTED	DESCRIPTION OF DEVIATIONS
Para. 4.2.1	Scanning Electron Microscope (SEM) Inspection may be performed using TIF document TIF 3.61.610.001.
Para. 4.2.2	Prior to Die Shear Test TIF may perform a Radiographic Inspection on the randomly chosen samples to be subjected to this test, using TIF document TI 50.42-3002.
Para. 4.2.3	Radiographic Inspection may be performed using TIF document TI 50.42-3002.