



europaean space agency
agence spatiale européenne

Pages 1 to 44

INTEGRATED CIRCUITS, SILICON MONOLITHIC,
HCMOS OCTAL BUS BUFFERS
WITH INVERTED 3-STATE OUTPUTS,
BASED ON TYPE 54HC240

ESA/SCC Detail Specification No. 9401/034



space components
coordination group

Issue/Rev.	Date	Approved by	
		SCCG Chairman	ESA Director General or his Deputy
Issue 1	November 1991		
Revision 'A'	March 1994		
Revision 'B'	March 2002		

**ESC**

ESA/SCC Detail Specification

No. 9401/034

PAGE 3

ISSUE 1

TABLE OF CONTENTS

	<u>Page</u>
1. <u>GENERAL</u>	5
1.1 Scope	5
1.2 Component Type Variants	5
1.3 Maximum Ratings	5
1.4 Parameter Derating Information	5
1.5 Physical Dimensions	5
1.6 Pin Assignment	5
1.7 Truth Table	5
1.8 Circuit Schematic	5
1.9 Functional Diagram	5
1.10 Handling Precautions	5
1.11 Input and Output Protection Networks	5
2. <u>APPLICABLE DOCUMENTS</u>	17
3. <u>TERMS, DEFINITIONS, ABBREVIATIONS, SYMBOLS AND UNITS</u>	17
4. <u>REQUIREMENTS</u>	17
4.1 General	17
4.2 Deviations from Generic Specification	17
4.2.1 Deviations from Special In-process Controls	17
4.2.2 Deviations from Final Production Tests	17
4.2.3 Deviations from Burn-in Tests	17
4.2.4 Deviations from Qualification Tests	17
4.2.5 Deviations from Lot Acceptance Tests	18
4.3 Mechanical Requirements	18
4.3.1 Dimension Check	18
4.3.2 Weight	18
4.4 Materials and Finishes	18
4.4.1 Case	18
4.4.2 Lead Material and Finish	18
4.5 Marking	18
4.5.1 General	18
4.5.2 Lead Identification	18
4.5.3 The SCC Component Number	19
4.5.4 Traceability Information	19
4.6 Electrical Measurements	19
4.6.1 Electrical Measurements at Room Temperature	19
4.6.2 Electrical Measurements at High and Low Temperatures	19
4.6.3 Circuits for Electrical Measurements	19
4.7 Burn-in Tests	19
4.7.1 Parameter Drift Values	19
4.7.2 Conditions for H.T.R.B. and Power Burn-in	19
4.7.3 Electrical Circuits for H.T.R.B. and Power Burn-in	19
4.8 Environmental and Endurance Tests	39
4.8.1 Electrical Measurements on Completion of Environmental-Tests	39
4.8.2 Electrical Measurements at Intermediate Points during Endurance Tests	39
4.8.3 Electrical Measurements on Completion of Endurance Tests	39
4.8.4 Conditions for Operating Life Tests	39
4.8.5 Electrical Circuits for Operating Life Tests	39
4.8.6 Conditions for High Temperature Storage Test	39



	<u>Page</u>
4.9 Total Dose Irradiation Testing	39
4.9.1 Application	39
4.9.2 Bias Conditions	39
4.9.3 Electrical Measurements	39

TABLES

1(a) Type Variants	6
1(b) Maximum Ratings	6
2 Electrical Measurements at Room Temperature - d.c. Parameters	20
Electrical Measurements at Room Temperature - a.c. Parameters	24
3 Electrical Measurements at High and Low Temperatures	26
4 Parameter Drift Values	34
5(a) Conditions for Burn-in High Temperature Reverse Bias, N-Channels	35
5(b) Conditions for Burn-in High Temperature Reverse Bias, P-Channels	35
5(c) Conditions for Power Burn-in and Operating Life Test	36
6 Electrical Measurements on Completion of Environmental Tests and at Intermediate Points and on Completion of Endurance Testing	40
7 Electrical Measurements During and on Completion of Irradiation Testing	42

FIGURES

1 Not applicable	
2 Physical Dimensions	7
3(a) Pin Assignment	14
3(b) Truth Table	14
3(c) Circuit Schematic	15
3(d) Functional Diagram	15
3(e) Input and Output Protection Networks	16
4 Circuits for Electrical Measurements	30
5(a) Electrical Circuit for Burn-in High Temperature Reverse Bias, N-Channels	37
5(b) Electrical Circuit for Burn-in High Temperature Reverse Bias, P-Channels	37
5(c) Electrical Circuit for Power Burn-in and Operating Life Test	38
6 Bias Conditions for Irradiation Testing	41

APPENDICES (Applicable to specific Manufacturers only)

'A' AGREED DEVIATIONS FOR TEXAS INSTRUMENTS (F)	43
'B' AGREED DEVIATIONS FOR STMICROELECTRONICS (F)	44

**1. GENERAL****1.1 SCOPE**

This specification details the ratings, physical and electrical characteristics, test and inspection data for a silicon, monolithic, high speed CMOS Octal Bus Buffer, with inverted 3-State Outputs, based on Type 54HC240. It shall be read in conjunction with ESA/SCC Generic Specification No. 9000, the requirements of which are supplemented herein.

1.2 COMPONENT TYPE VARIANTS

Variants of the basic type integrated circuits specified herein, which are also covered by this specification, are given in Table 1(a).

1.3 MAXIMUM RATINGS

The maximum ratings, which shall not be exceeded at any time during use or storage, applicable to the integrated circuits specified herein, are as scheduled in Table 1(b).

Maximum ratings shall only be exceeded during testing to the extent specified in this specification and when stipulated in Test Methods and Procedures of the applicable ESA/SCC Generic Specification.

1.4 PARAMETER DERATING INFORMATION (FIGURE 1)

Not applicable.

1.5 PHYSICAL DIMENSIONS

As per Figure 2.

1.6 PIN ASSIGNMENT

As per Figure 3(a).

1.7 TRUTH TABLE

As per Figure 3(b).

1.8 CIRCUIT SCHEMATIC

As per Figure 3(c).

1.9 FUNCTIONAL DIAGRAM

As per Figure 3(d).

1.10 HANDLING PRECAUTIONS

These devices are susceptible to damage by electrostatic discharge. Therefore, suitable precautions shall be employed for protection during all phases of manufacture, testing, packaging, shipment and any handling.

These components are Categorized as Class 2 with a Minimum Critical Path Failure Voltage of 2500 Volts.

1.11 INPUT AND OUTPUT PROTECTION NETWORKS

Protection networks shall be incorporated into each input and output as shown in Figure 3(e).

**TABLE 1(a) - TYPE VARIANTS**

VARIANT	CASE	FIGURE	LEAD MATERIAL AND/OR FINISH
01	FLAT	2(a)	G2 or G8
02	FLAT	2(a)	G4
03	D.I.L.	2(b)	G2 or G8
04	D.I.L.	2(b)	G4
05	CHIP CARRIER	2(c)	2
06	FLAT	2(d)	G4
07	D.I.L.	2(e)	G4
08	CHIP CARRIER	2(f)	7
09	CHIP CARRIER	2(f)	4
10	SO CERAMIC	2(g)	G2
11	SO CERAMIC	2(g)	G4

TABLE 1(b) - MAXIMUM RATINGS

NO.	CHARACTERISTICS	SYMBOL	MAXIMUM RATINGS	UNITS	REMARKS
1	Supply Voltage	V_{DD}	-0.5 to +7.0	V	Note 1
2	Input Voltage	V_{IN}	-0.5 to $V_{DD} + 0.5$	V	Notes 1, 2
3	Output Voltage	V_{OUT}	-0.5 to $V_{DD} + 0.5$	V	Notes 1, 3
4	Device Dissipation (Continuous)	P_D	420	mW	Note 4
5	Supply Current	I_{DDop}	70	mA	
6	Operating Temperature Range	T_{op}	-55 to +125	°C	T_{amb}
7	Storage Temperature Range	T_{stg}	-65 to +150	°C	
8	Soldering Temperature For FP and DIP For CCP	T_{sol}	+265 +245	°C	Note 5 Note 6

NOTES

- Device is functional for $2.0V \leq V_{DD} \leq 6.0V$.
- Input current limited to $I_{IC} = \pm 20mA$.
- Output current limited to $I_{OUT} = \pm 35mA$.
- The maximum device dissipation is determined by $I_{DDop} \text{ max. } (70mA) \times 6.0V$.
- Duration 10 seconds maximum at a distance of not less than 1.5mm from the device body and the same lead shall not be resoldered until 3 minutes have elapsed.
- Duration 5 seconds maximum and the same terminal shall not be resoldered until 3 minutes have elapsed.

FIGURE 1 - PARAMETER DERATING INFORMATION

Not applicable.



FIGURE 2 - PHYSICAL DIMENSIONS

FIGURE 2(a) - FLAT PACKAGE, 20-PIN

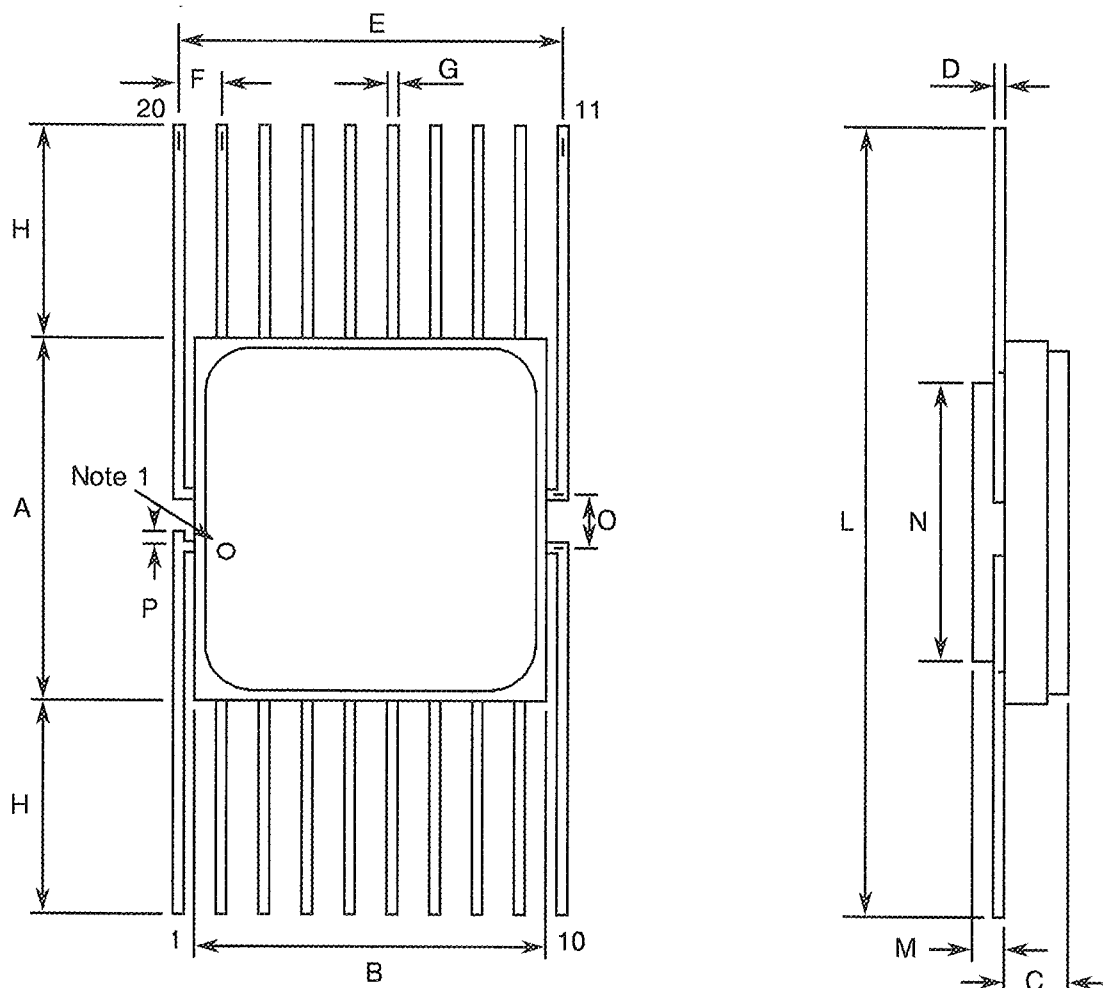

SYMBOL	MILLIMETRES		NOTES
	MIN	MAX	
A	9.98	10.34	
B	9.98	10.34	
C	1.45	1.78	
D	0.10	0.18	8
E	11.30	11.56	
F	1.27 TYPICAL		5, 9
G	0.38	0.48	8
H	7.24	8.16	8
L	24.46	26.67	
M	0.45	0.55	
N	7.87 TYPICAL		
O	1.27 TYPICAL		
P	0.10	0.25	

NOTES: See Page 13.



FIGURE 2 - PHYSICAL DIMENSIONS (CONTINUED)

FIGURE 2(b) - DUAL-IN-LINE PACKAGE, 20-PIN

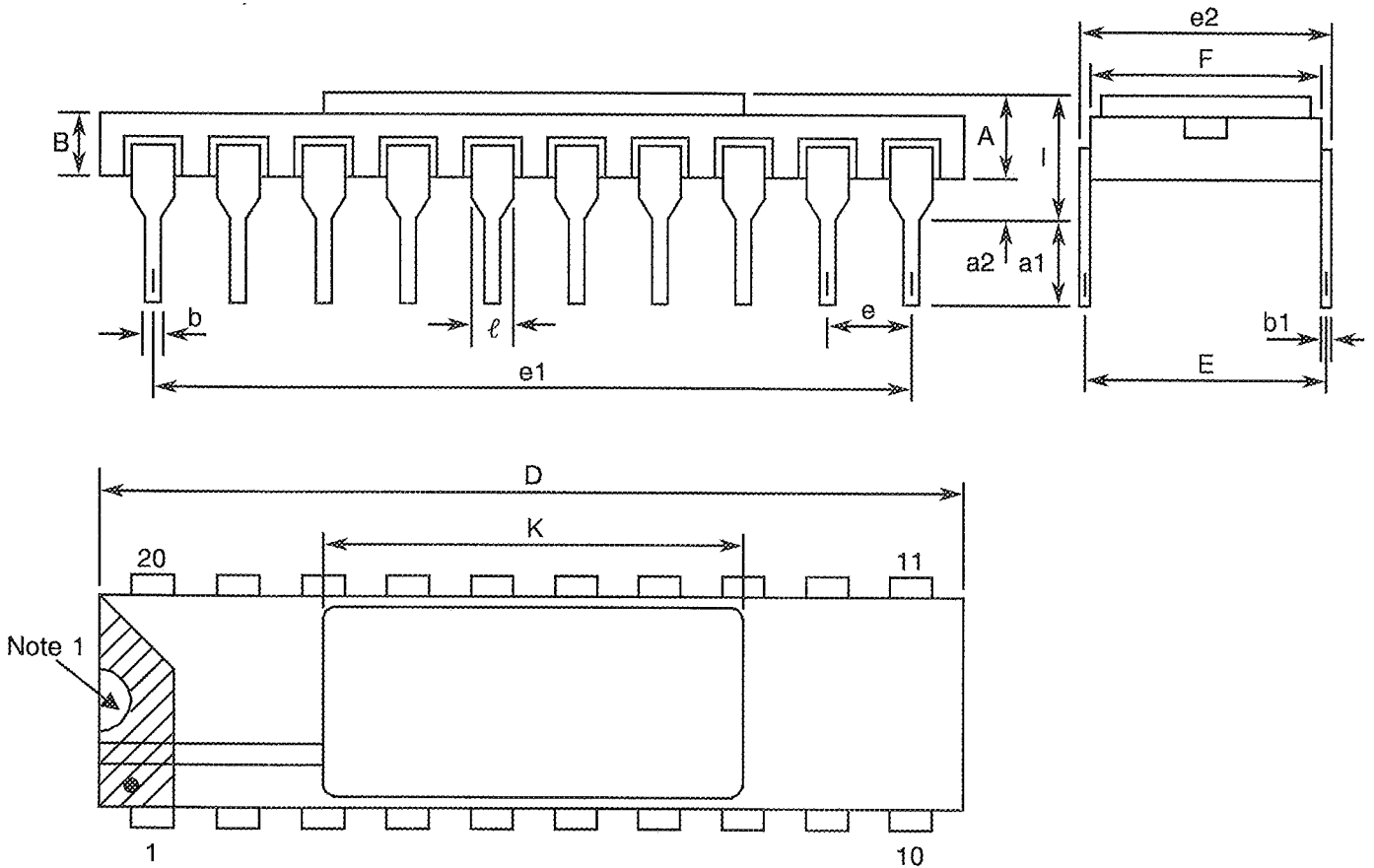

SYMBOL	MILLIMETRES		NOTES
	MIN	MAX	
A	2.10	2.72	
a1	3.0	3.70	
a2	0.63	1.14	3
B	1.93	2.39	
b	0.40	0.50	8
b1	0.20	0.30	8
D	25.14	25.65	
E	7.36	7.87	
e	2.54 TYPICAL		6, 9
e1	22.73	22.99	
e2	7.62	8.12	
F	7.11	7.62	
I	-	3.86	
K	11.30	11.56	
l	1.27 TYPICAL		8

NOTES: See Page 13.



FIGURE 2 - PHYSICAL DIMENSIONS (CONTINUED)

FIGURE 2(c) - CHIP CARRIER - 20-TERMINAL

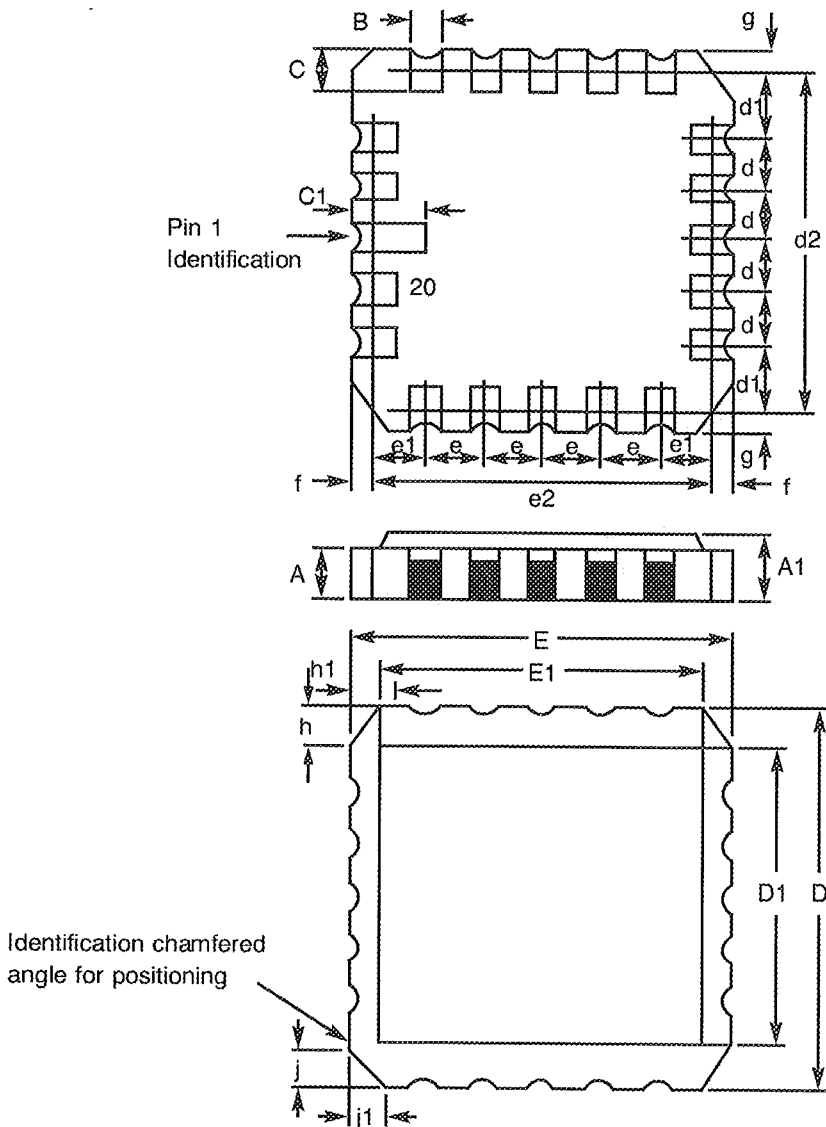

DIMENSIONS	MILLIMETRES		NOTES
	MIN	MAX	
A	1.14	1.95	
A1	1.63	2.36	
B	0.55	0.72	3
C	1.06	1.47	3
C1	1.91	2.41	
D	8.67	9.09	
D1	7.21	7.52	
d, d1	1.27	TYPICAL	4
d2	7.62	TYPICAL	
E	8.67	9.09	
E1	7.21	7.52	
e, e1	1.27	TYPICAL	4
e2	7.62	TYPICAL	
f, g	-	0.76	
h, h1	1.01	TYPICAL	6
j, j1	0.51	TYPICAL	5

NOTES: See Page 13.



FIGURE 2 - PHYSICAL DIMENSIONS (CONTINUED)

FIGURE 2(d) - FLAT PACKAGE, 20-PIN

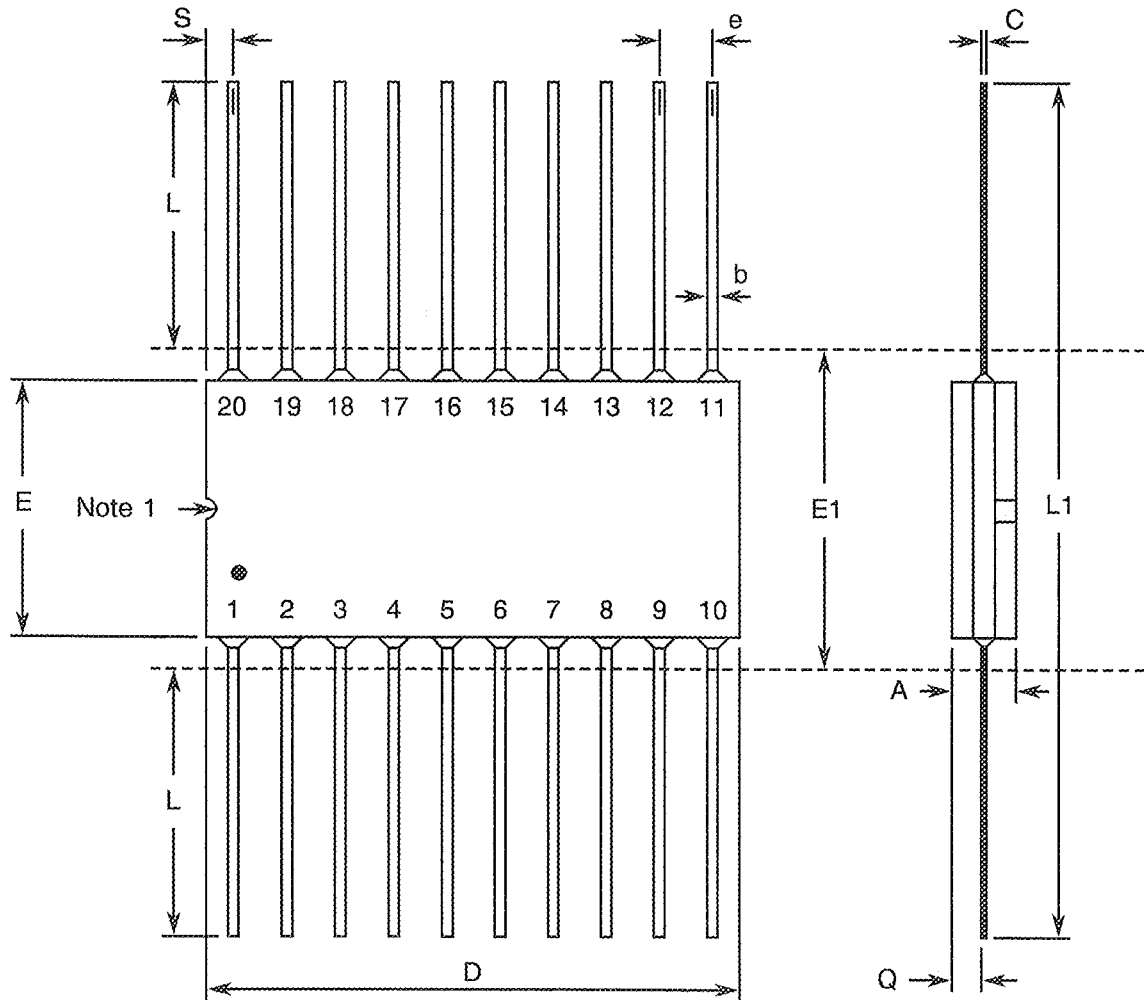

SYMBOL	MILLIMETRES		NOTES
	MIN	MAX	
A	1.14	2.34	
b	0.38	0.56	8
C	0.08	0.23	8
D	-	12.95	4
E	6.60	7.65	
E1	8.15 TYPICAL		4
e	1.27 TYPICAL		5, 9
L	6.35	9.40	8
L1	18.90	25.90	
Q	0.25	1.02	2
S	0.13	1.14	7

NOTES: See Page 13.



FIGURE 2 - PHYSICAL DIMENSIONS (CONTINUED)

FIGURE 2(e) - DUAL-IN-LINE PACKAGE, 20-PIN

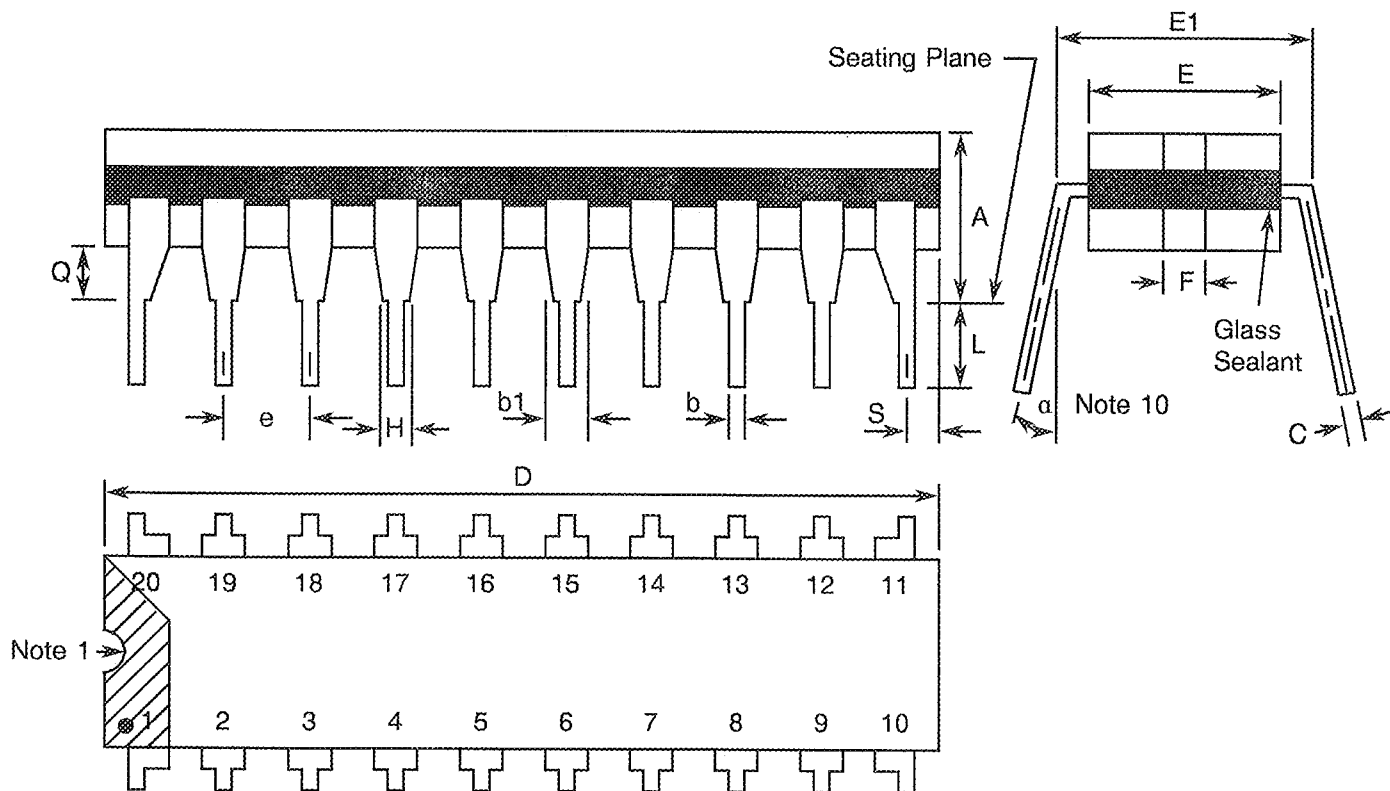

SYMBOL	MILLIMETRES		NOTES
	MIN	MAX	
A	-	5.08	
b	0.38	0.66	8
b1	-	1.78	8
C	0.20	0.44	8
D	23.62	24.76	4
E	6.22	7.62	4
E1	7.37	8.13	
e	2.54 TYPICAL		6, 9
F	1.27 TYPICAL		
H	0.76	-	
L	3.30	5.08	8
Q	0.51	-	3
S	0.38	1.27	7
a	0°	15°	10

NOTES: See Page 13.



FIGURE 2 - PHYSICAL DIMENSIONS (CONTINUED)

FIGURE 2(f) - SQUARE CHIP CARRIER PACKAGE (3 LAYER BASE), 20 TERMINAL

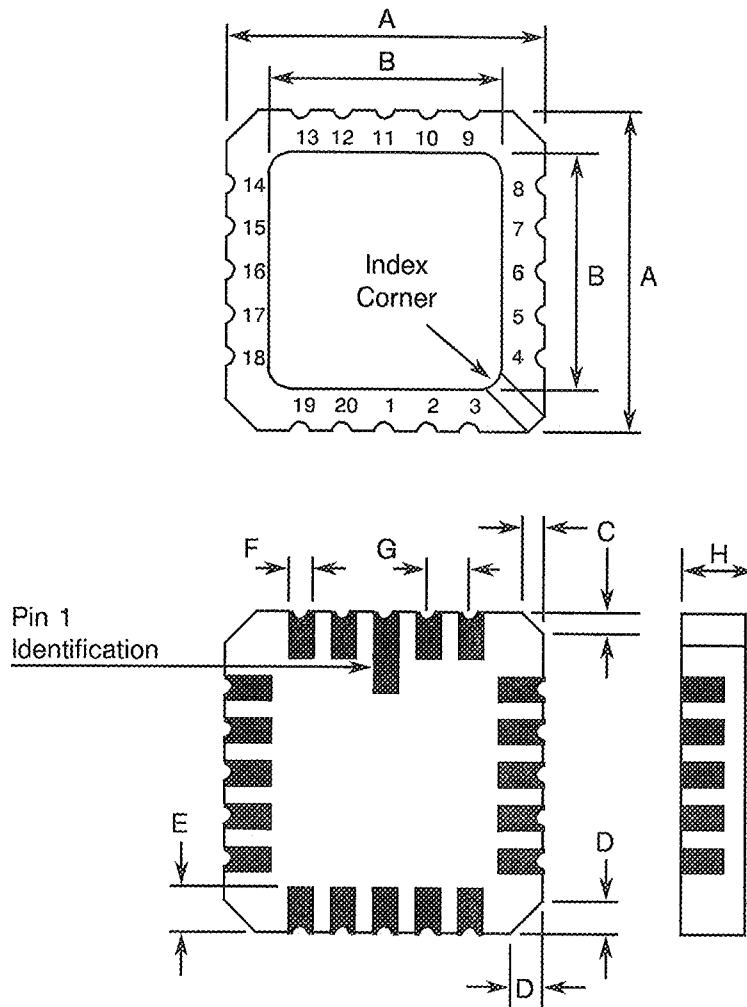

SYMBOL	MILLIMETRES		NOTES
	MIN	MAX	
A	8.69	9.09	
B	7.80	9.09	
C	0.25	0.51	11
D	0.89	1.14	12
E	1.14	1.40	8
F	0.56	0.71	8
G	1.27 TYPICAL		5, 9
H	1.63	2.54	

NOTES: See Page 13.

**SCC**ESA/SCC Detail Specification
No. 9401/034

Rev. 'B'

PAGE 13

ISSUE 1

FIGURE 2 - PHYSICAL DIMENSIONS (CONTINUED)**NOTES TO FIGURES 2(a) TO 2(g) INCLUSIVE**

1. Index area: a notch, letter or dot shall be located adjacent to Pin 1 and shall be within the shaded area shown. For chip carrier packages the index shall be as defined in Figures 2(c) and 2(f).
2. Dimension Q shall be measured at the point of exit of the lead from the body.
3. The dimension shall be measured from the seating plane to the base plane.
4. The dimension allows for off-centre lids, meniscus and glass overrun.
5. The true position pin or terminal spacing is 1.27mm between centrelines. Each pin or terminal centreline shall be located within $\pm 0.13\text{mm}$ of its true longitudinal position relative to Pin 1 and the highest pin number.
6. The true position pin spacing is 2.54mm between centrelines. Each pin centreline shall be located within $\pm 0.25\text{mm}$ of its true longitudinal position relative to Pin 1 and the highest pin number.
7. Applies to all 4 corners.
8. All leads or terminals.
9. 18 spaces for flat, SO and dual-in-line packages.
16 spaces for chip carrier packages.
10. Lead centreline when α is 0° .
11. Index corner only - 2 dimensions.
12. 3 non-index corners - 6 dimensions.



FIGURE 2 - PHYSICAL DIMENSIONS (CONTINUED)

FIGURE 2(g) - SMALL OUTLINE CERAMIC PACKAGE, 20-PIN

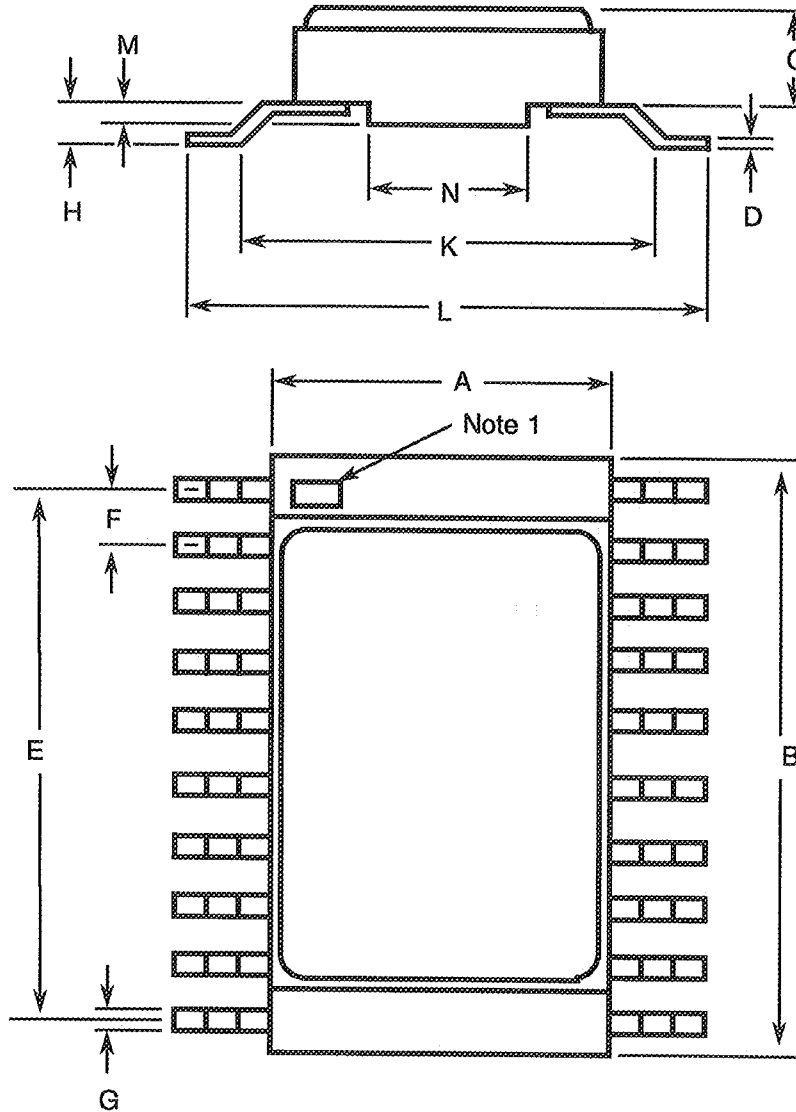

SYMBOL	MILLIMETRES		NOTES
	MIN.	MAX.	
A	6.99	7.24	
B	12.83	13.08	
C	1.47	1.85	
D	0.076	0.152	8
E	11.3	11.56	
F	1.27 TYPICAL		5, 9
G	0.38	0.48	8
H	0.60	0.90	8
K	9.00 TYPICAL		
L	10	10.65	
M	0.33	0.43	
N	4.31 TYPICAL		

NOTES: See Page 13.



FIGURE 3(a) - PIN ASSIGNMENT

DUAL-IN-LINE, SO AND FLAT PACKAGE

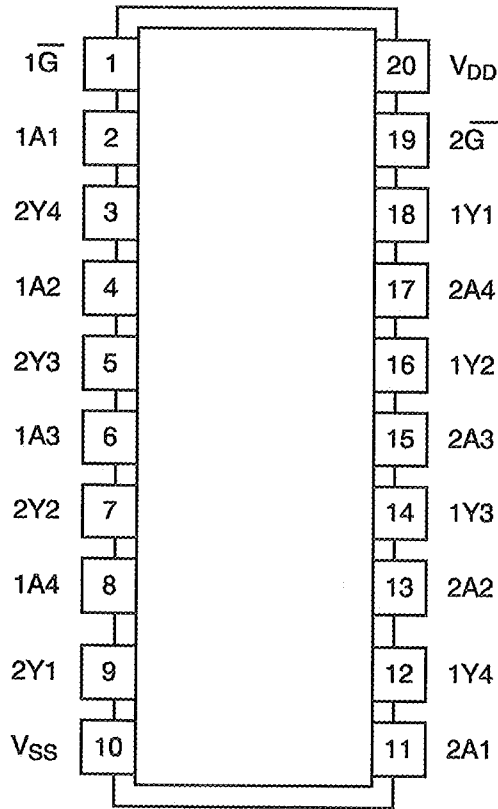

TOP VIEW

CHIP CARRIER PACKAGE

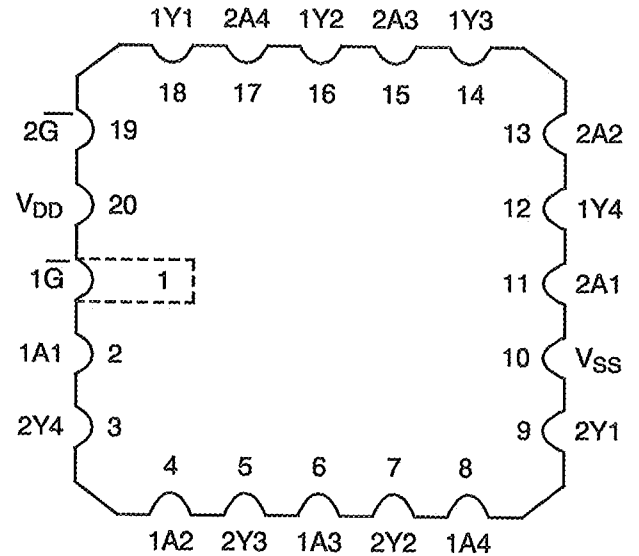

TOP VIEW

FIGURE 3(b) - TRUTH TABLE (EACH BUFFER)

INPUTS		OUTPUT
\overline{G}	A	1Y
L	H	L
L	L	H
H	X	Z

NOTES 1. Logic Level Definitions: L = Low Level, H = High Level, Z = High Impedance, X = Irrelevant.

FIGURE 3(c) - CIRCUIT SCHEMATIC

Not applicable.

FIGURE 3(d) - FUNCTIONAL DIAGRAM

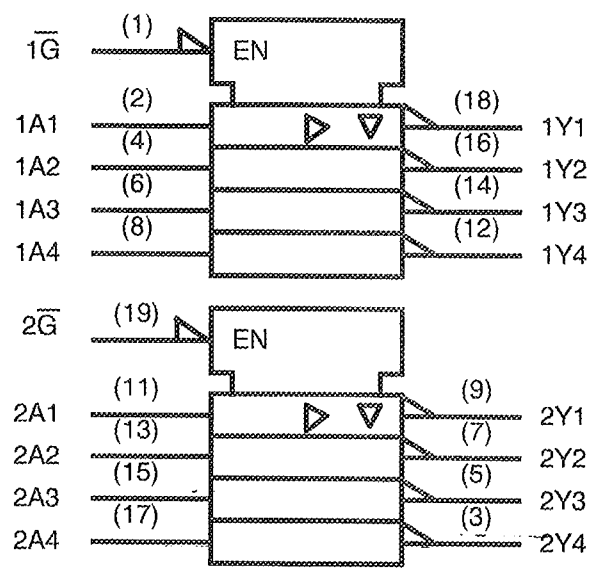
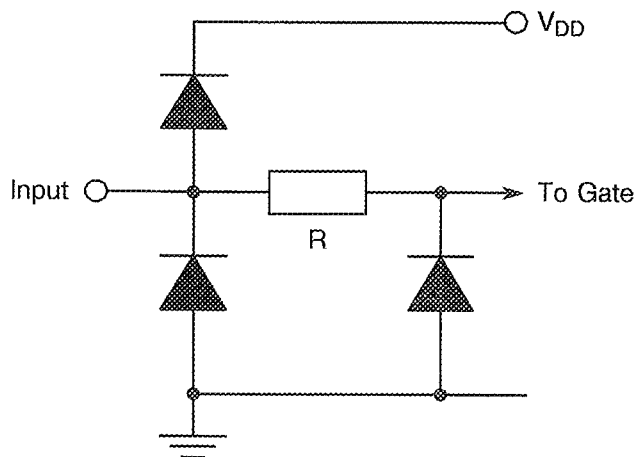

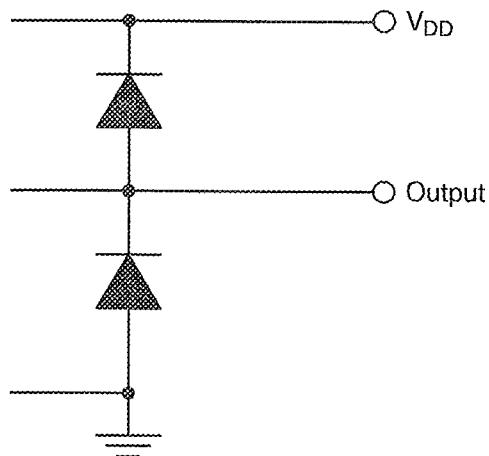

FIGURE 3(e) - INPUT AND OUTPUT PROTECTION NETWORKS

INPUT PROTECTION



OUTPUT PROTECTION



VARIANTS 01 TO 05

INPUT PROTECTION

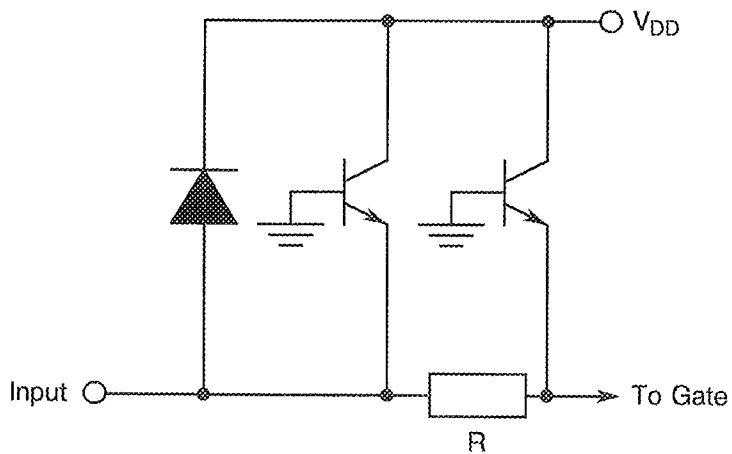

OUTPUT PROTECTION

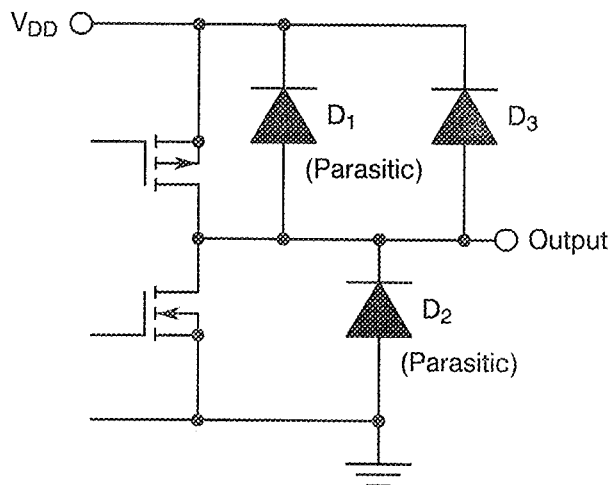

VARIANTS 06 TO 09

**2. APPLICABLE DOCUMENTS**

The following documents form part of this specification and shall be read in conjunction with it:-

- (a) ESA/SCC Generic Specification No. 9000 for Integrated Circuits.
- (b) MIL-STD-883, Test Methods and Procedures for Micro-electronics.

3. TERMS, DEFINITIONS, ABBREVIATIONS, SYMBOLS AND UNITS

For the purpose of this specification, the terms, definitions, abbreviations, symbols and units specified in ESA/SCC Basic Specification No. 21300 shall apply. In addition, the following symbols are used:

V_{IC} = Input Clamp Voltage.

I_{IC} = Input Clamp Diode Current.

4. REQUIREMENTS**4.1 GENERAL**

The complete requirements for procurement of the integrated circuits specified herein are stated in this specification and ESA/SCC Generic Specification No. 9000 for Integrated Circuits. Deviations from the Generic Specification, applicable to this specification only, are listed in Para. 4.2.

Deviations from the applicable Generic Specification and this Detail Specification, formally agreed with specific Manufacturers on the basis that the alternative requirements are equivalent to the ESA/SCC requirements and do not affect the components' reliability, are listed in the appendices attached to this specification.

4.2 DEVIATIONS FROM GENERIC SPECIFICATION**4.2.1 Deviations from Special In-process Controls**

- (a) Para. 5.2.2, Total Dose Irradiation Testing: Shall be performed during irradiation qualification and maintenance of qualification.
- (b) Para. 5.2.2, Total Dose Irradiation Testing: Shall be performed during procurement on an irradiation lot acceptance basis at the total dose irradiation level specified in the Purchase Order.

4.2.2 Deviations from Final Production Tests (Chart II)

None.

4.2.3 Deviations from Burn-in Tests (Chart III)

None.

4.2.4 Deviations from Qualification Tests (Chart IV)

None.

**SCC**

ESA/SCC Detail Specification

No. 9401/034

Rev. 'B'

PAGE 18

ISSUE 1

4.2.5 Deviations from Lot Acceptance Tests (Chart V)
None.

4.3 MECHANICAL REQUIREMENTS

4.3.1 Dimension Check

The dimensions of the integrated circuits specified herein shall be checked. They shall conform to those shown in Figure 2.

4.3.2 Weight

The maximum weight of the integrated circuits specified herein shall be 3.2 grammes for the dual-in-line package, 0.9 grammes for the flat and SO packages and 0.6 grammes for the chip carrier package.

4.4 MATERIALS AND FINISHES

The materials shall be as specified herein. Where a definite material is not specified, a material which will enable the integrated circuits specified herein to meet the performance requirements of this specification shall be used. Acceptance or approval of any constituent material does not guarantee acceptance of the finished product.

4.4.1 Case

The case shall be hermetically sealed and have a metal body with hard glass seals or a ceramic body and the lids shall be welded, brazed, preform-soldered or glass frit sealed.

4.4.2 Lead Material and Finish

For dual-in-line and flat packages, the material shall be Type 'G' with either Type '4' or Type '2 or 8' finish in accordance with the requirements of ESA/SCC Basic Specification No. 23500. For chip carrier packages the finish shall be Type '2', Type '4' or Type '7' in accordance with the requirements of ESA/SCC Basic Specification No. 23500. For SO ceramic packages, the material shall be Type 'G' with either Type '2' or Type '4' finish in accordance with the requirements of ESA/SCC Basic Specification No. 23500. (See Table 1(a) for Type Variants).

4.5 MARKING

4.5.1 General

The marking of all components delivered to this specification shall be in accordance with the requirements of ESA/SCC Basic Specification No. 21700. Each component shall be marked in respect of:-

- (a) Lead Identification.
- (b) The SCC Component Number.
- (c) Traceability Information.

4.5.2 Lead Identification

For dual-in-line, flat and SO packages, an index shall be located at the top of the package in the position defined in Note 1 to Figure 2 or, alternatively, a tab may be used to identify Pin No. The pin numbering must be read with the index or tab on the left-hand side. For chip carrier packages, the index shall be as defined by Figures 2(c) and 2(f).

4.5.3 The SCC Component Number

Each component shall bear the SCC Component Number which shall be constituted and marked as follows:

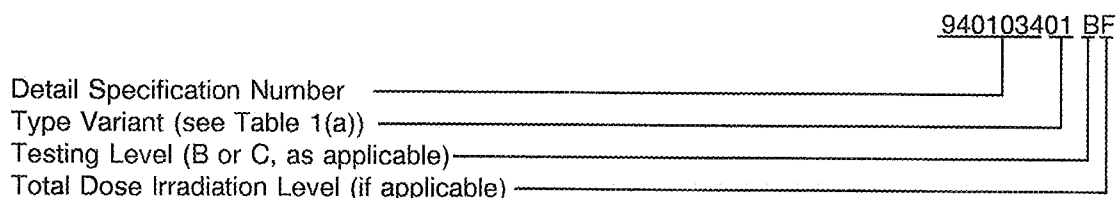

The Total Dose Irradiation Level designation shall be added for those devices for which a sample has been successfully tested to the level in question. For these devices, a code letter shall be added in accordance with the requirements of ESA/SCC Basic Specification No. 22900.

4.5.4 Traceability Information

Each component shall be marked in respect of traceability information in accordance with the requirements of ESA/SCC Basic Specification No. 21700.

4.6 ELECTRICAL MEASUREMENTS

4.6.1 Electrical Measurements at Room Temperature

The parameters to be measured in respect of electrical characteristics are scheduled in Table 2. Unless otherwise specified, the measurements shall be performed at $T_{amb} = +22 \pm 3$ °C.

4.6.2 Electrical Measurements at High and Low Temperatures

The parameters to be measured at high and low temperatures are scheduled in Table 3. The measurements shall be performed at $T_{amb} = +125 (+0 -5)$ °C and $-55 (+5 -0)$ °C respectively.

4.6.3 Circuits for Electrical Measurements

Circuits and test sequences for use in performing electrical measurements listed in Tables 2 and 3 of this specification are shown in Figure 4.

4.7 BURN-IN TESTS

4.7.1 Parameter Drift Values

The parameter drift values applicable to H.T.R.B. and Power Burn-in are specified in Table 4 of this specification. Unless otherwise stated, measurements shall be performed at $T_{amb} = +22 \pm 3$ °C. The parameter drift values (Δ) applicable to the parameters scheduled, shall not be exceeded. In addition to these drift value requirements, the appropriate limit value specified for a given parameter in Table 2 shall not be exceeded.

For H.T.R.B. Burn-in, the parameter drift values (Δ) shall be applied before the N-Channel (0 hours) and after the P-Channel (144 hours) burn-in.

4.7.2 Conditions for H.T.R.B. and Power Burn-in

The requirements for H.T.R.B. and Power Burn-in are specified in Section 7 of ESA/SCC Generic Specification No. 9000. The conditions for H.T.R.B. and Power Burn-in shall be as specified in Tables 5(a), 5(b) and 5(c) of this specification.

4.7.3 Electrical Circuits for H.T.R.B. and Power Burn-in

Circuits for use in performing the H.T.R.B. and Power Burn-in tests are shown in Figures 5(a), 5(b) and 5(c) of this specification.

**TABLE 2 - ELECTRICAL MEASUREMENTS AT ROOM TEMPERATURE - d.c. PARAMETERS**

NO.	CHARACTERISTICS	SYMBOL	TEST METHOD MIL-STD 883	TEST FIG.	TEST CONDITIONS (PINS UNDER TEST D/F = DIP AND FP C = CCP)	LIMITS		UNIT
						MIN	MAX	
1	Functional Test 1	-	-	3(b)	Verify Truth Table without Load. $V_{IL} = 0.3V$, $V_{IH} = 1.5V$ $V_{DD} = 2.0V$, $V_{SS} = 0V$ $t_r < 1.0\mu s$, $f = 10kHz$ (min) Note 1	-	-	-
2	Functional Test 2	-	-	3(b)	Verify Truth Table without Load. $V_{IL} = 0.9V$, $V_{IH} = 3.15V$ $V_{DD} = 4.5V$, $V_{SS} = 0V$ $t_r = t_f < 500ns$ $f = 10kHz$ (min) Note 1	-	-	-
3	Functional Test 3	-	-	3(b)	Verify Truth Table without Load. $V_{IL} = 1.2V$, $V_{IH} = 4.2V$ $V_{DD} = 6.0V$, $V_{SS} = 0V$ $t_r = t_f < 400ns$ $f = 10kHz$ (min) Note 1	-	-	-
4 to 7	Quiescent Current	I_{DD}	3005	4(a)	$V_{IL} = 0V$, $V_{IH} = 6.0V$ $V_{DD} = 6.0V$, $V_{SS} = 0V$ All Outputs Open Note 2 (Pin 20)	-	0.4	μA
8 to 17	Input Current Low Level	I_{IL}	3009	4(b)	V_{IN} (Under Test) = 0V V_{IN} (Remaining Inputs) = 6.0V $V_{DD} = 6.0V$, $V_{SS} = 0V$ (Pins 1-2-4-6-8-11-13-15-17-19)	-	-50	nA
18 to 27	Input Current High Level	I_{IH}	3010	4(c)	V_{IN} (Under Test) = 6.0V V_{IN} (Remaining Inputs) = 0V $V_{DD} = 6.0V$, $V_{SS} = 0V$ (Pins 1-2-4-6-8-11-13-15-17-19)	-	50	nA

NOTES: See Page 23.

**TABLE 2 - ELECTRICAL MEASUREMENTS AT ROOM TEMPERATURE - d.c. PARAMETERS (CONT'D)**

NO.	CHARACTERISTICS	SYMBOL	TEST METHOD MIL-STD 883	TEST FIG.	TEST CONDITIONS (PINS UNDER TEST D/F = DIP AND FP C = CCP)	LIMITS		UNIT
						MIN	MAX	
28 to 35	Output Voltage Low Level 1	V_{OL1}	3007	4(d)	Buffer Under Test: $V_{IN} = 1.5V$ $V_{IN(\overline{G})} = 0.3V$ $I_{OL} = 20\mu A$ All Other Inputs: $V_{IN} = 0V$ $V_{DD} = 2.0V, V_{SS} = 0V$ (Pins 3-5-7-9-12-14-16-18)	-	0.1	V
36 to 43	Output Voltage Low Level 2	V_{OL2}	3007	4(d)	Buffer Under Test: $V_{IN} = 3.15V$ $V_{IN(\overline{G})} = 0.9V$ $I_{OL} = 20\mu A$ All other Inputs: $V_{IN} = 0V$ $V_{DD} = 4.5V, V_{SS} = 0V$ (Pins 3-5-7-9-12-14-16-18)	-	0.1	V
44 to 51	Output Voltage Low Level 3	V_{OL3}	3007	4(d)	Buffer Under Test: $V_{IN} = 4.2V$ $V_{IN(\overline{G})} = 1.2V$ $I_{OL} = 20\mu A$ All other Inputs: $V_{IN} = 0V$ $V_{DD} = 6.0V, V_{SS} = 0V$ (Pins 3-5-7-9-12-14-16-18)	-	0.1	V
52 to 59	Output Voltage Low Level 4	V_{OL4}	3007	4(d)	Buffer Under Test: $V_{IN} = 3.15V$ $V_{IN(\overline{G})} = 0.9V$ $I_{OL} = 6.0mA$ All other Inputs: $V_{IN} = 0V$ $V_{DD} = 4.5V, V_{SS} = 0V$ (Pins 3-5-7-9-12-14-16-18)	-	0.26	V
60 to 67	Output Voltage Low Level 5	V_{OL5}	3007	4(d)	Buffer Under Test: $V_{IN} = 4.2V$ $V_{IN(\overline{G})} = 1.2V$ $I_{OL} = 7.8mA$ All other Inputs: $V_{IN} = 0V$ $V_{DD} = 6.0V, V_{SS} = 0V$ (Pins 3-5-7-9-12-14-16-18)	-	0.26	V

NOTES: See Page 23.

**TABLE 2 - ELECTRICAL MEASUREMENTS AT ROOM TEMPERATURE - d.c. PARAMETERS (CONT'D)**

NO.	CHARACTERISTICS	SYMBOL	TEST METHOD MIL-STD 883	TEST FIG.	TEST CONDITIONS (PINS UNDER TEST D/F = DIP AND FP C = CCP)	LIMITS		UNIT
						MIN	MAX	
68 to 75	Output Voltage High Level 1	V_{OH1}	3006	4(e)	Buffer Under Test: $V_{IN} = 0.3V$ $V_{IN(\overline{G})} = 0.3V$ $I_{OH} = -20\mu A$ All other Inputs: $V_{IN} = 0V$ $V_{DD} = 2.0V, V_{SS} = 0V$ (Pins 3-5-7-9-12-14-16-18)	1.9	-	V
76 to 83	Output Voltage High Level 2	V_{OH2}	3006	4(e)	Buffer Under Test: $V_{IN} = 0.9V$ $V_{IN(\overline{G})} = 0.9V$ $I_{OH} = -20\mu A$ All Other Inputs: $V_{IN} = 0V$ $V_{DD} = 4.5V, V_{SS} = 0V$ (Pins 3-5-7-9-12-14-16-18)	4.4	-	V
84 to 91	Output Voltage High Level 3	V_{OH3}	3006	4(e)	Buffer Under Test: $V_{IN} = 1.2V$ $V_{IN(\overline{G})} = 1.2V$ $I_{OH} = -20\mu A$ All Other Inputs: $V_{IN} = 0V$ $V_{DD} = 6.0V, V_{SS} = 0V$ (Pins 3-5-7-9-12-14-16-18)	5.9	-	V
92 to 99	Output Voltage High Level 4	V_{OH4}	3006	4(e)	Buffer Under Test: $V_{IN} = 0.9V$ $V_{IN(\overline{G})} = 0.9V$ $I_{OH} = -6.0mA$ All Other Inputs: $V_{IN} = 0V$ $V_{DD} = 4.5V, V_{SS} = 0V$ (Pins 3-5-7-9-12-14-16-18)	3.98	-	V
100 to 107	Output Voltage High Level 5	V_{OH5}	3006	4(e)	Buffer Under Test: $V_{IN} = 1.2V$ $V_{IN(\overline{G})} = 1.2V$ $I_{OH} = -7.8mA$ All Other Inputs: $V_{IN} = 0V$ $V_{DD} = 6.0V, V_{SS} = 0V$ (Pins 3-5-7-9-12-14-16-18)	5.48	-	V

NOTES: See Page 23.

**TABLE 2 - ELECTRICAL MEASUREMENTS AT ROOM TEMPERATURE - d.c. PARAMETERS (CONT'D)**

NO.	CHARACTERISTICS	SYMBOL	TEST METHOD MIL-STD 883	TEST FIG.	TEST CONDITIONS (PINS UNDER TEST D/F = DIP AND FP C = CCP)	LIMITS		UNIT
						MIN	MAX	
108	Threshold Voltage N-Channel	V_{THN}	-	4(f)	$\bar{1}\bar{G}$ Input at Ground All Other Inputs: $V_{IN} = 5.0V$ $V_{DD} = 5.0V, I_{SS} = -10\mu A$ (Pin 10)	-0.45	-1.45	V
109	Threshold Voltage P-Channel	V_{THP}	-	4(g)	$\bar{1}\bar{G}$ Input at Ground All Other Inputs: $V_{IN} = -5.0Vdc$ $V_{SS} = -5.0V, I_{DD} = 10\mu A$ (Pin 20)	0.45	1.35	V
110 to 119	Input Clamp Voltage (to V_{SS})	V_{IC1}	-	4(h)	I_{IN} (Under Test) = $-0.1mA$ $V_{DD} = \text{Open}, V_{SS} = 0V$ All Other Pins Open (Pins 1-2-4-6-8-11-13-15-17-19)	-0.4	-0.9	V
120 to 129	Input Clamp Voltage (to V_{DD})	V_{IC2}	-	4(h)	I_{IN} (Under Test) = $0.1mA$ $V_{DD} = 0V, V_{SS} = \text{Open}$, All Other Pins Open (Pins 1-2-4-6-8-11-13-15-17-19)	0.4	0.9	V
130 to 137	Output Leakage Current Third State (Low Level Applied)	I_{OLZ}	3006	4(i)	$V_{IN(\bar{G})} = 6.0V$ $V_{IN}(\text{Remaining Inputs}) = 0V$ $V_{OUT} = 0V$ $V_{DD} = 6.0V, V_{SS} = 0V$ (Pins 3-5-7-9-12-14-16-18)	-	-0.5	μA
138 to 145	Output Leakage Current Third State (High Level Applied)	I_{OLZ}	3006	4(i)	$V_{IN(\bar{G})} = 6.0V$ $V_{IN}(\text{Remaining Inputs}) = 0V$ $V_{OUT} = 6.0V$ $V_{DD} = 6.0V, V_{SS} = 0V$ (Pins 3-5-7-9-12-14-16-18)	-	0.5	μA

NOTES

1. Maximum time to output comparator strobe $30\mu s$.
2. Test each pattern of Figure 4(a).
3. Guaranteed but not tested.
4. Measurements shall be performed on a 100% basis go-no-go, with read and record on a sample basis, LTPD7 (32 pieces) after Chart III (Burn-in) Tests.



TABLE 2 - ELECTRICAL MEASUREMENTS AT ROOM TEMPERATURE - a.c. PARAMETERS

NO.	CHARACTERISTICS	SYMBOL	TEST METHOD MIL-STD 883	TEST FIG.	TEST CONDITIONS (PINS UNDER TEST D/F = DIP AND FP C = CCP)	LIMITS		UNIT
						MIN	MAX	
146 to 155	Input Capacitance	C_{IN}	3012	4(j)	V_{IN} (Not Under Test) = 0Vdc $V_{DD} = V_{SS} = 0V$ Note 3 (Pins 1-2-4-6-8-11-13-15-17-19)	-	10	pF
156	Propagation Delay Low to High (1A1 to 1Y1)	t_{PLH}	3003	4(k)	Buffer Under Test: $V_{IN} =$ Pulse Generator $V_{IN(1G)} = 0.9V$ V_{IN} (Remaining Inputs) = 0V $V_{DD} = 4.5V, V_{SS} = 0V$ Note 4 <u>Pins</u> 2 to 18	-	30	ns
157	Propagation Delay High to Low (1A1 to 1Y1)	t_{PHL}	3003	4(k)	Buffer Under Test: $V_{IN} =$ Pulse Generator $V_{IN(1G)} = 0.9V$ V_{IN} (Remaining Inputs) = 0V $V_{DD} = 4.5V, V_{SS} = 0V$ Note 4 <u>Pins</u> 2 to 18	-	30	ns
158	Transition Time Low to High	t_{TLH}	3004	4(k)	Buffer Under Test: $V_{IN} =$ Pulse Generator $V_{IN(1G)} = 0.9V$ V_{IN} (Remaining Inputs) = 0V $V_{DD} = 4.5V, V_{SS} = 0V$ Note 4 (Pin 18)	-	12	ns
159	Transition Time High to Low	t_{THL}	3004	4(k)	Buffer Under Test: $V_{IN} =$ Pulse Generator $V_{IN(1G)} = 0.9V$ V_{IN} (Remaining Inputs) = 0V $V_{DD} = 4.5V, V_{SS} = 0V$ Note 4 (Pin 18)	-	12	ns

NOTES: See Page 23.

**TABLE 2 - ELECTRICAL MEASUREMENTS AT ROOM TEMPERATURE - a.c. PARAMETERS (CONT'D)**

NO.	CHARACTERISTICS	SYMBOL	TEST METHOD MIL-STD 883	TEST FIG.	TEST CONDITIONS (PINS UNDER TEST D/F = DIP AND FP C = CCP)	LIMITS		UNIT
						MIN	MAX	
160	Output Enable Time High Impedance to Low Output (2G to 2Y1)	tPZL	3003	4(k)	V _{IN(2G)} = Pulse Generator V _{IN(2A1)} = 3.15V V _{IN} (Remaining Inputs) = 0V V _{DD} = 4.5V, V _{SS} = 0V Note 4 <u>Pins</u> 19 to 9	-	40	ns
161	Output Enable Time High Impedance to High Output (2G to 2Y1)	tPZH	3003	4(k)	V _{IN(2G)} = Pulse Generator V _{IN(2A1)} = 0.9V V _{IN} (Remaining Inputs) = 0V V _{DD} = 4.5V, V _{SS} = 0V Note 4 <u>Pins</u> 19 to 9	-	40	ns
162	Output Disable Time Low Output to High Impedance (2G to 2Y1)	tPLZ	3003	4(k)	V _{IN(2G)} = Pulse Generator V _{IN(2A1)} = 3.15V V _{IN} (Remaining Inputs) = 0V V _{DD} = 4.5V, V _{SS} = 0V Note 4 <u>Pins</u> 19 to 9	-	40	ns
163	Output Disable Time High Output to High Impedance (2G to 2Y1)	tPHZ	3003	4(k)	V _{IN(2G)} = Pulse Generator V _{IN(2A1)} = 0.9V V _{IN} (Remaining Inputs) = 0V V _{DD} = 4.5V, V _{SS} = 0V Note 4 <u>Pins</u> 19 to 9	-	40	ns

NOTES: See Page 23.

**TABLE 3 - ELECTRICAL MEASUREMENTS AT HIGH AND LOW TEMPERATURES**

NO.	CHARACTERISTICS	SYMBOL	TEST METHOD MIL-STD 883	TEST FIG.	TEST CONDITIONS (PINS UNDER TEST D/F = DIP AND FP C = CCP)	LIMITS		UNIT
						MIN	MAX	
1	Functional Test 1	-	-	3(b)	Verify Truth Table without Load. $V_{IL} = 0.3V$, $V_{IH} = 1.5V$ $V_{DD} = 2.0V$, $V_{SS} = 0V$ $t_r < 1.0\mu s$, $f = 10kHz$ (min) Note 1	-	-	-
2	Functional Test 2	-	-	3(b)	Verify Truth Table without Load. $V_{IL} = 0.9V$, $V_{IH} = 3.15V$ $V_{DD} = 4.5V$, $V_{SS} = 0V$ $t_r = t_f < 500ns$ $f = 10kHz$ (min) Note 1	-	-	-
3	Functional Test 3	-	-	3(b)	Verify Truth Table without Load. $V_{IL} = 1.2V$, $V_{IH} = 4.2V$ $V_{DD} = 6.0V$, $V_{SS} = 0V$ $t_r = t_f < 400ns$ $f = 10kHz$ (min) Note 1	-	-	-
4 to 7	Quiescent Current	I_{DD}	3005	4(a)	$V_{IL} = 0V$, $V_{IH} = 6.0V$ $V_{DD} = 6.0V$, $V_{SS} = 0V$ All Outputs Open Note 2 (Pin 20)	-	8.0	μA
8 to 17	Input Current Low Level	I_{IL}	3009	4(b)	V_{IN} (Under Test) = $0V$ V_{IN} (Remaining Inputs) = $6.0V$ $V_{DD} = 6.0V$, $V_{SS} = 0V$ (Pins 1-2-4-6-8-11-13-15- 17-19)	-	-1.0	μA
18 to 27	Input Current High Level	I_{IH}	3010	4(c)	V_{IN} (Under Test) = $6.0V$ V_{IN} (Remaining Inputs) = $0V$ $V_{DD} = 6.0V$, $V_{SS} = 0V$ (Pins 1-2-4-6-8-11-13-15- 17-19)	-	1.0	μA

NOTES: See Page 23.

**TABLE 3 - ELECTRICAL MEASUREMENTS AT HIGH AND LOW TEMPERATURES (CONT'D)**

NO.	CHARACTERISTICS	SYMBOL	TEST METHOD MIL-STD 883	TEST FIG.	TEST CONDITIONS (PINS UNDER TEST D/F = DIP AND FP C = CCP)	LIMITS		UNIT
						MIN	MAX	
28 to 35	Output Voltage Low Level 1	V_{OL1}	3007	4(d)	Buffer Under Test: $V_{IN} = 1.5V$ $V_{IN(\overline{G})} = 0.3V$ $I_{OL} = 20\mu A$ All Other Inputs: $V_{IN} = 0V$ $V_{DD} = 2.0V, V_{SS} = 0V$ (Pins 3-5-7-9-12-14-16-18)	-	0.1	V
36 to 43	Output Voltage Low Level 2	V_{OL2}	3007	4(d)	Buffer Under Test: $V_{IN} = 3.15V$ $V_{IN(\overline{G})} = 0.9V$ $I_{OL} = 20\mu A$ All other Inputs: $V_{IN} = 0V$ $V_{DD} = 4.5V, V_{SS} = 0V$ (Pins 3-5-7-9-12-14-16-18)	-	0.1	V
44 to 51	Output Voltage Low Level 3	V_{OL3}	3007	4(d)	Buffer Under Test: $V_{IN} = 4.2V$ $V_{IN(\overline{G})} = 1.2V$ $I_{OL} = 20\mu A$ All other Inputs: $V_{IN} = 0V$ $V_{DD} = 6.0V, V_{SS} = 0V$ (Pins 3-5-7-9-12-14-16-18)	-	0.1	V
52 to 59	Output Voltage Low Level 4	V_{OL4}	3007	4(d)	Buffer Under Test: $V_{IN} = 3.15V$ $V_{IN(\overline{G})} = 0.9V$ $I_{OL} = 6.0mA$ All other Inputs: $V_{IN} = 0V$ $V_{DD} = 4.5V, V_{SS} = 0V$ (Pins 3-5-7-9-12-14-16-18)	-	0.4	V
60 to 67	Output Voltage Low Level 5	V_{OL5}	3007	4(d)	Buffer Under Test: $V_{IN} = 4.2V$ $V_{IN(\overline{G})} = 1.2V$ $I_{OL} = 7.8mA$ All other Inputs: $V_{IN} = 0V$ $V_{DD} = 6.0V, V_{SS} = 0V$ (Pins 3-5-7-9-12-14-16-18)	-	0.4	V

NOTES: See Page 23.

**TABLE 3 - ELECTRICAL MEASUREMENTS AT HIGH AND LOW TEMPERATURES (CONT'D)**

NO.	CHARACTERISTICS	SYMBOL	TEST METHOD MIL-STD 883	TEST FIG.	TEST CONDITIONS (PINS UNDER TEST D/F = DIP AND FP C = CCP)	LIMITS		UNIT
						MIN	MAX	
68 to 75	Output Voltage High Level 1	V_{OH1}	3006	4(e)	Buffer Under Test: $V_{IN} = 0.3V$ $V_{IN(\overline{G})} = 0.3V$ $I_{OH} = -20\mu A$ All other Inputs: $V_{IN} = 0V$ $V_{DD} = 2.0V, V_{SS} = 0V$ (Pins 3-5-7-9-12-14-16-18)	1.9	-	V
76 to 83	Output Voltage High Level 2	V_{OH2}	3006	4(e)	Buffer Under Test: $V_{IN} = 0.9V$ $V_{IN(\overline{G})} = 0.9V$ $I_{OH} = -20\mu A$ All Other Inputs: $V_{IN} = 0V$ $V_{DD} = 4.5V, V_{SS} = 0V$ (Pins 3-5-7-9-12-14-16-18)	4.4	-	V
84 to 91	Output Voltage High Level 3	V_{OH3}	3006	4(e)	Buffer Under Test: $V_{IN} = 1.2V$ $V_{IN(\overline{G})} = 1.2V$ $I_{OH} = -20\mu A$ All Other Inputs: $V_{IN} = 0V$ $V_{DD} = 6.0V, V_{SS} = 0V$ (Pins 3-5-7-9-12-14-16-18)	5.9	-	V
92 to 99	Output Voltage High Level 4	V_{OH4}	3006	4(e)	Buffer Under Test: $V_{IN} = 0.9V$ $V_{IN(\overline{G})} = 0.9V$ $I_{OH} = -6.0mA$ All Other Inputs: $V_{IN} = 0V$ $V_{DD} = 4.5V, V_{SS} = 0V$ (Pins 3-5-7-9-12-14-16-18)	3.7	-	V
100 to 107	Output Voltage High Level 5	V_{OH5}	3006	4(e)	Buffer Under Test: $V_{IN} = 1.2V$ $V_{IN(\overline{G})} = 1.2V$ $I_{OH} = -7.8mA$ All Other Inputs: $V_{IN} = 0V$ $V_{DD} = 6.0V, V_{SS} = 0V$ (Pins 3-5-7-9-12-14-16-18)	5.2	-	V

NOTES: See Page 23.

**TABLE 3 - ELECTRICAL MEASUREMENTS AT HIGH AND LOW TEMPERATURES (CONT'D)**

NO.	CHARACTERISTICS	SYMBOL	TEST METHOD MIL-STD 883	TEST FIG.	TEST CONDITIONS (PINS UNDER TEST D/F = DIP AND FP C = CCP)	LIMITS		UNIT
						MIN	MAX	
110 to 119	Input Clamp Voltage (to V _{SS})	V _{IC1}	-	4 (h)	I _{IN} (Under Test) = -0.1mA V _{DD} = Open, V _{SS} = 0V All Other Pins Open (Pins 1-2-4-6-8-11-13-15-17-19)	-0.1	-1.2	V
120 to 129	Input Clamp Voltage (to V _{DD})	V _{IC2}	-	4 (h)	I _{IN} (Under Test) = 0.1mA V _{DD} = 0V, V _{SS} = Open, All Other Pins Open (Pins 1-2-4-6-8-11-13-15-17-19)	0.1	1.2	V
130 to 137	Output Leakage Current Third State (Low Level Applied)	I _{OZL}	3006	4(i)	V _{IN(G)} = 6.0V V _{IN} (Remaining Inputs) = 0V V _{OUT} = 0V V _{DD} = 6.0V, V _{SS} = 0V (Pins 3-5-7-9-12-14-16-18)	-	- 10	μA
138 to 145	Output Leakage Current Third State (High Level Applied)	I _{OZH}	3006	4(i)	V _{IN(G)} = 6.0V V _{IN} (Remaining Inputs) = 0V V _{OUT} = 6.0V V _{DD} = 6.0V, V _{SS} = 0V (Pins 3-5-7-9-12-14-16-18)	-	10	μA

NOTES: See Page 23.



FIGURE 4 - CIRCUITS FOR ELECTRICAL MEASUREMENTS

FIGURE 4(a) - QUIESCENT CURRENT TEST TABLE

PATTERN NO.	INPUTS										OUTPUTS								D.C. SUPPLY	
	1	2	4	6	8	11	13	15	17	19	3	5	7	9	12	14	16	18	10	20
1	0	0	0	0	0	0	0	0	0	0	OPEN								V_{SS}	V_{DD}
2	0	1	1	1	1	1	1	1	1	0	OPEN								\downarrow	\downarrow
3	1	1	1	1	1	0	0	0	0	0	OPEN								\downarrow	\downarrow
4	0	0	0	0	0	1	1	1	1	1	OPEN								\downarrow	\downarrow

NOTES

- Figure 4 (a) illustrates one series of test patterns. Any other pattern series must be agreed with the Qualifying Space Agency and shall be included as an Appendix.
- Logic Level Definitions: 1 = V_{IH} = V_{DD} , 0 = V_{IL} = V_{SS} .

FIGURE 4(b) - INPUT CURRENT LOW LEVEL

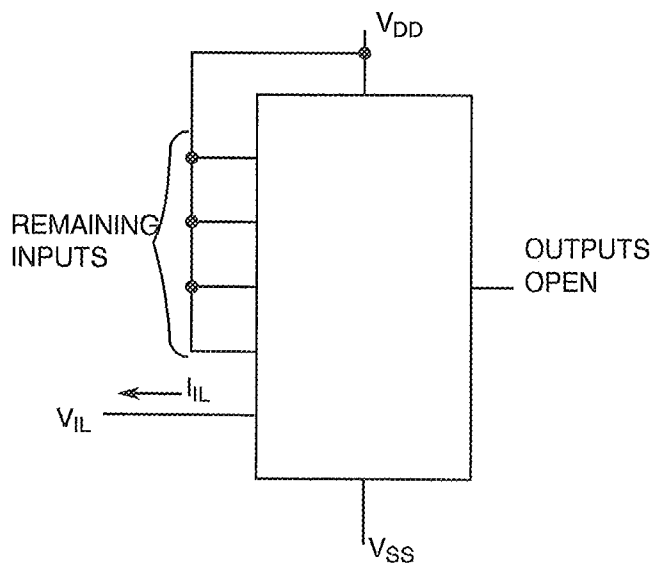

NOTES

- Each input to be tested separately.

FIGURE 4(c) - INPUT CURRENT HIGH LEVEL

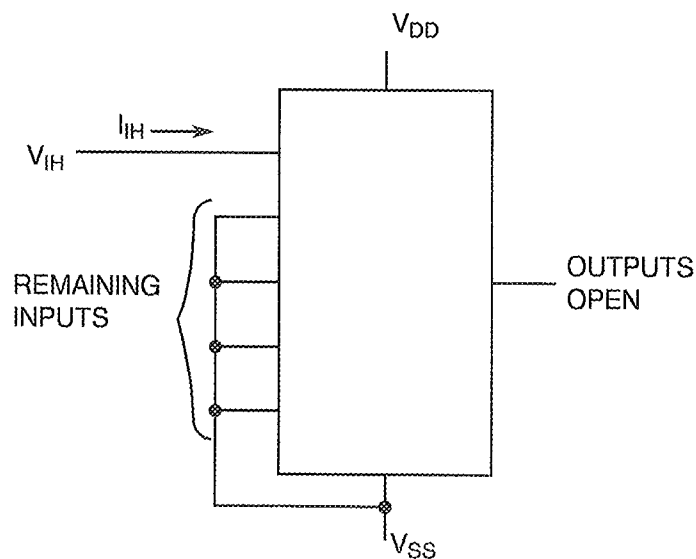

NOTES

- Each input to be tested separately.



FIGURE 4 - CIRCUITS FOR ELECTRICAL MEASUREMENTS (CONTINUED)

FIGURE 4(d) - OUTPUT VOLTAGE LOW LEVEL

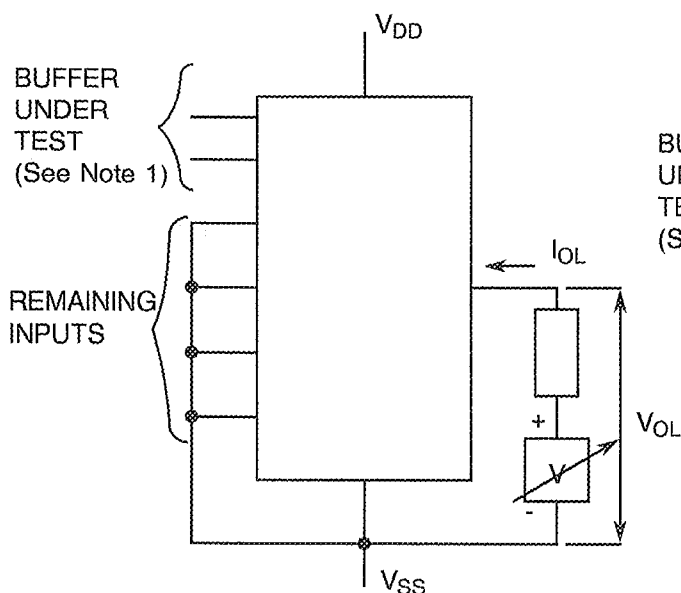

NOTES

1. $V_{IN} = V_{IH}(\min)$ with \bar{G} at $V_{IL}(\max)$.
2. Each output to be tested separately.

FIGURE 4(e) - OUTPUT VOLTAGE HIGH LEVEL

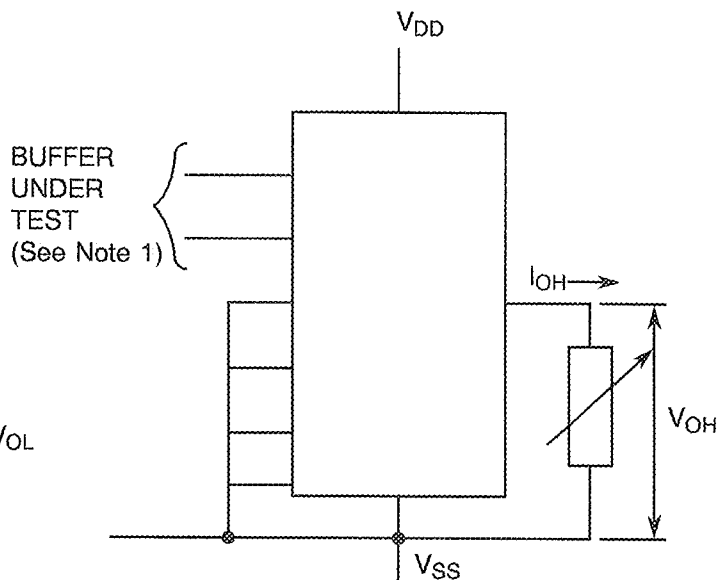

NOTES

1. $V_{IN} = V_{IL}(\max)$ with \bar{G} at $V_{IL}(\max)$.
2. Each output to be tested separately.

FIGURE 4(f) - THRESHOLD VOLTAGE N-CHANNEL

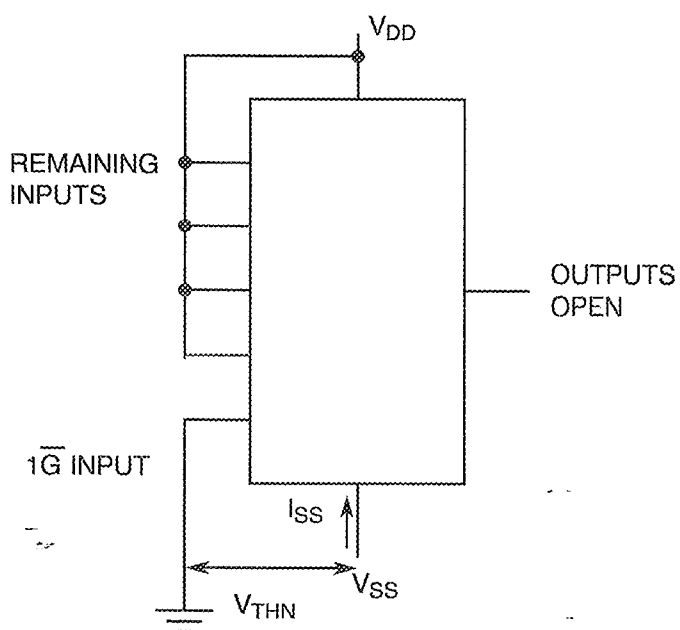

FIGURE 4(g) - THRESHOLD VOLTAGE P-CHANNEL

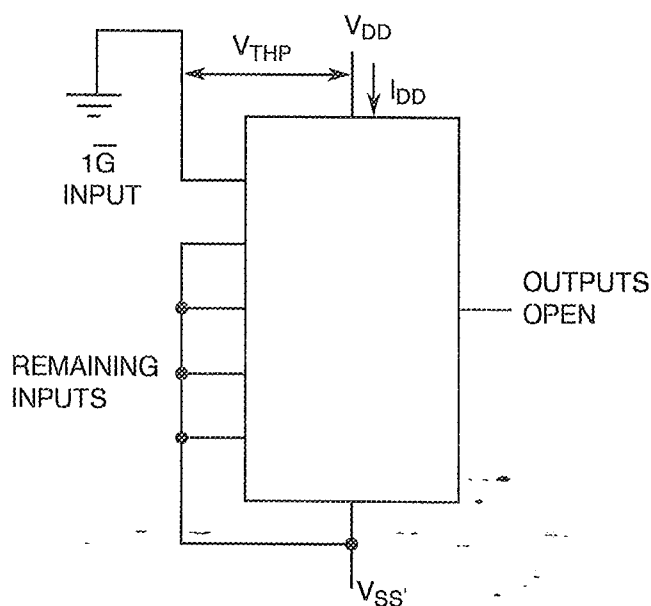
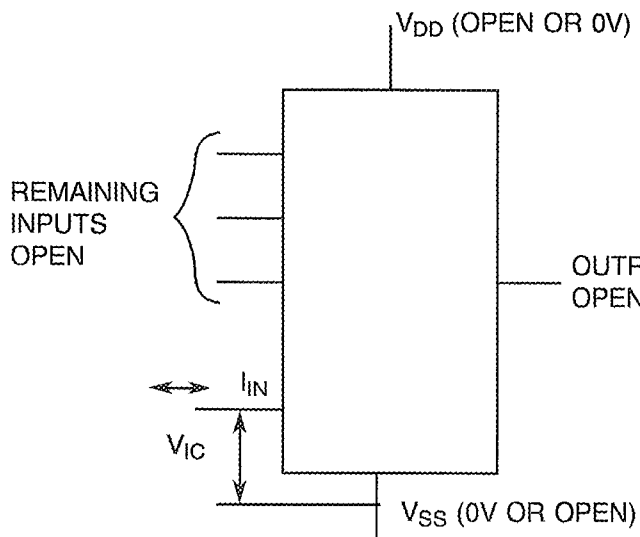



FIGURE 4 - CIRCUITS FOR ELECTRICAL MEASUREMENTS (CONTINUED)

FIGURE 4(h) - INPUT CLAMP VOLTAGE



NOTES

1. Each input to be tested separately.

FIGURE 4(i) - OUTPUT LEAKAGE CURRENT THIRD STATE

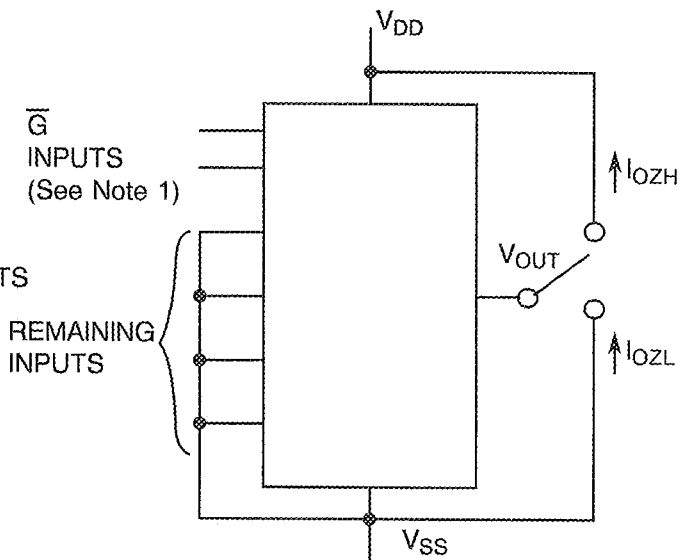

NOTES

1. G inputs at 6.0V.
2. Each output to be tested separately.

FIGURE 4(j) - INPUT CAPACITANCE

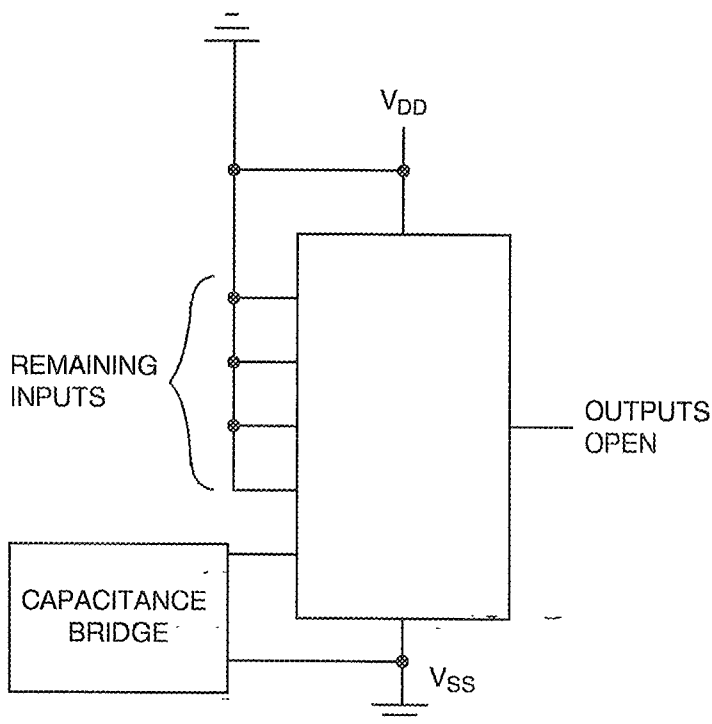

NOTES

1. Each input to be tested separately.
2. $f = 100\text{kHz}$ to 1MHz .



FIGURE 4 - CIRCUITS FOR ELECTRICAL MEASUREMENTS (CONTINUED)

FIGURE 4(k) - PROPAGATION DELAY AND TRANSITION TIME

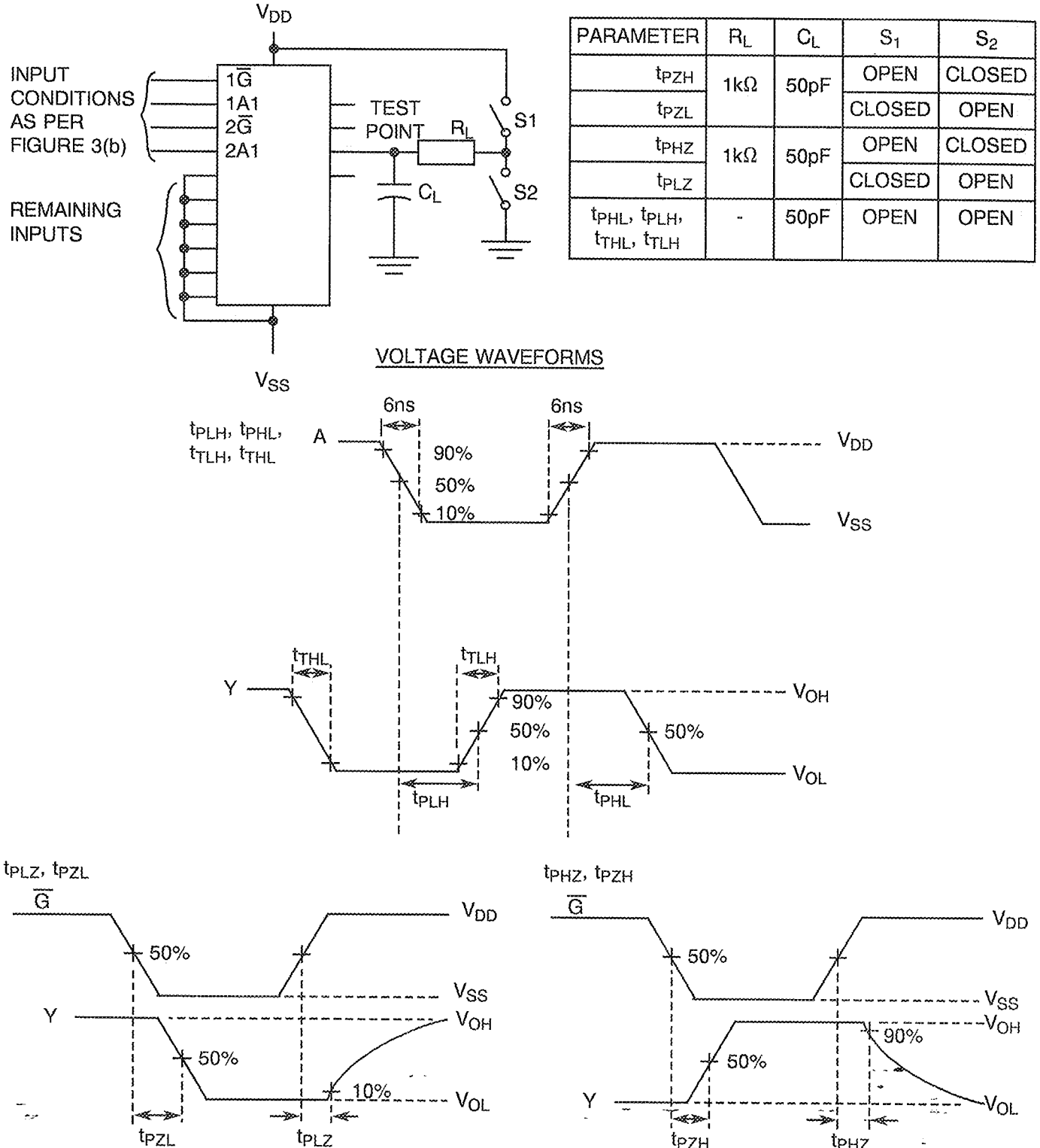

NOTES

1. Pulse Generator: $V_p = 0$ to V_{DD} , t_r and $t_f \leq 6ns$, $f = 1.0MHz$ minimum, 50% Duty Cycle, $Z_{OUT} = 50\Omega$.
2. $C_L = 50pF \pm 5\%$ including scope, wiring and stray capacitance without package in test fixture.

**TABLE 4 - PARAMETER DRIFT VALUES**

NO.	CHARACTERISTICS	SYMBOL	SPEC. AND/OR TEST METHOD	TEST CONDITIONS	CHANGE LIMITS (Δ)	UNIT
4 to 7	Quiescent Current	I_{DD}	As per Table 2	As per Table 2	± 120	nA
8 to 17	Input Current Low Level	I_{IL}	As per Table 2	As per Table 2	± 20	nA
18 to 27	Input Current High Level	I_{IH}	As per Table 2	As per Table 2	± 20	nA
52 to 59	Output Voltage Low Level 4	V_{OL4}	As per Table 2	As per Table 2	± 0.026	V
92 to 99	Output Voltage High Level 4	V_{OH4}	As per Table 2	As per Table 2	± 0.2	V
108	Threshold Voltage N-Channel	V_{THN}	As per Table 2	As per Table 2	± 0.3	V
109	Threshold Voltage P-Channel	V_{THP}	As per Table 2	As per Table 2	± 0.3	V

**TABLE 5(a) - CONDITIONS FOR BURN-IN HIGH TEMPERATURE REVERSE BIAS, N-CHANNELS**

NO.	CHARACTERISTICS	SYMBOL	CONDITION	UNIT
1	Ambient Temperature	T_{amb}	+125(+0-5)	°C
2	Outputs - (Pins 3-5-7-9-12-14-16-18)	V_{OUT}	Open or V_{SS}	-
3	Inputs - (Pins 1-2-4-6-8-11-13-15-17-19)	V_{IN}	V_{SS}	V
4	Positive Supply Voltage (Pin 20)	V_{DD}	6.0(+0-0.5)	V
5	Negative Supply Voltage (Pin 10)	V_{SS}	0	V
6	Duration	t	72	Hours

NOTES

1. Input Protection Resistor = 680 Ω min. to 47k Ω max.
2. Output Load = 1k Ω min. to 10k Ω max.

TABLE 5(b) - CONDITIONS FOR BURN-IN HIGH TEMPERATURE REVERSE BIAS, P-CHANNELS

NO.	CHARACTERISTICS	SYMBOL	CONDITION	UNIT
1	Ambient Temperature	T_{amb}	+125(+0-5)	°C
2	Outputs - (Pins 3-5-7-9-12-14-16-18)	V_{OUT}	Open or V_{DD}	-
3	Inputs - (Pins 1-2-4-6-8-11-13-15-17-19)	V_{IN}	V_{DD}	V
4	Positive Supply Voltage (Pin 20)	V_{DD}	6.0(+0-0.5)	V
5	Negative Supply Voltage (Pin 10)	V_{SS}	0	V
6	Duration	t	72	Hours

NOTES

1. Input Protection Resistor = 680 Ω min. to 47k Ω max.
2. Output Load = 1k Ω min. to 10k Ω max.

**TABLE 5(c) - CONDITIONS FOR POWER BURN-IN AND OPERATING LIFE TEST**

NO.	CHARACTERISTICS	SYMBOL	CONDITIONS	UNIT
1	Ambient Temperature	T_{amb}	+125(+0-5)	°C
2	Outputs - (Pins 3-5-7-9-12-14-16-18)	V_{OUT}	V_{DD}	V
3	Inputs - (Pins 2-4-6-8-11-13-15-17)	V_{IN}	V_{GEN}	V _{ac}
4	Inputs - (Pins 1-19)	V_{IN}	V_{SS}	V
5	Pulse Voltage	V_{GEN}	0V to V_{DD}	V _{ac}
6	Pulse Frequency Square Wave	f	100k ± 10% 50 ± 15% Duty Cycle $t_r = t_f \leq 400ns$	Hz
7	Positive Supply Voltage (Pin 20)	V_{DD}	6.0(+0-0.5)	V
8	Negative Supply Voltage (Pin 10)	V_{SS}	0	V

NOTES

1. Input Protection Resistor = 680Ω min. to 47kΩ max.
2. Output Load = 1kΩ min. to 10kΩ max.



FIGURE 5(a) - ELECTRICAL CIRCUIT FOR BURN-IN HIGH TEMPERATURE REVERSE BIAS, N-CHANNELS

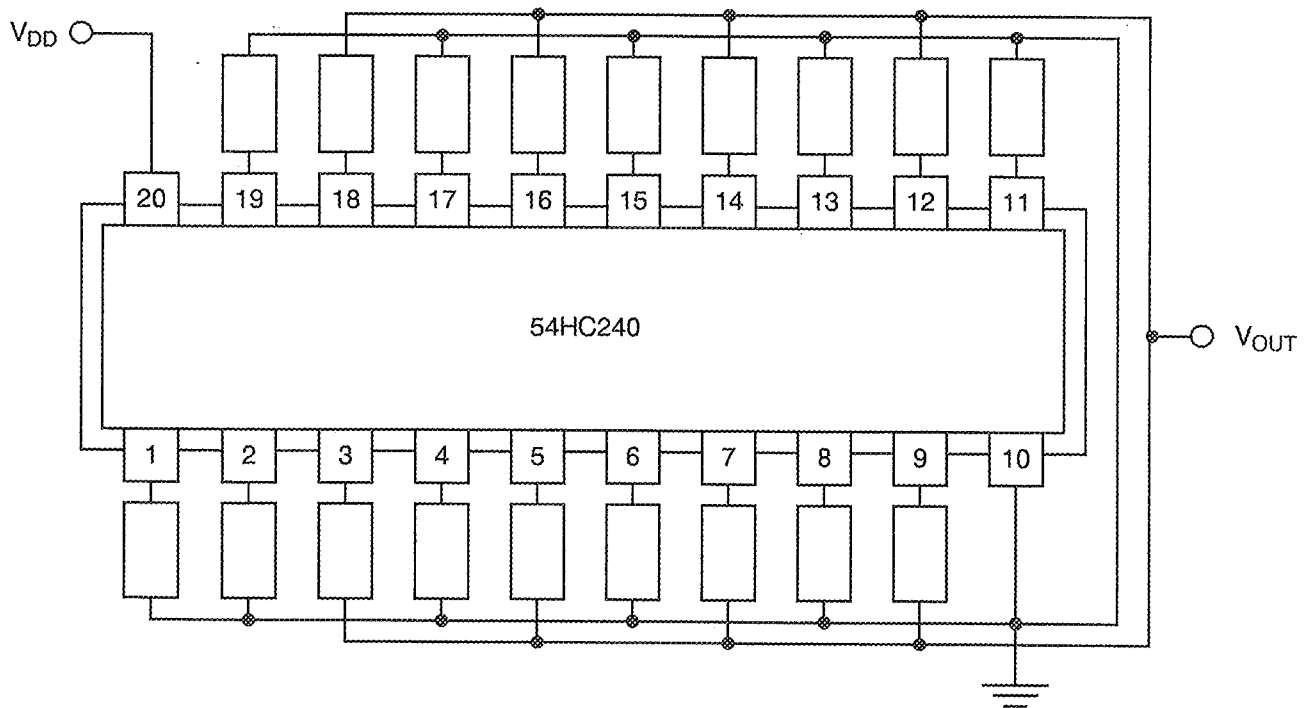

FIGURE 5(b) - ELECTRICAL CIRCUIT FOR BURN-IN HIGH TEMPERATURE REVERSE BIAS, P-CHANNELS

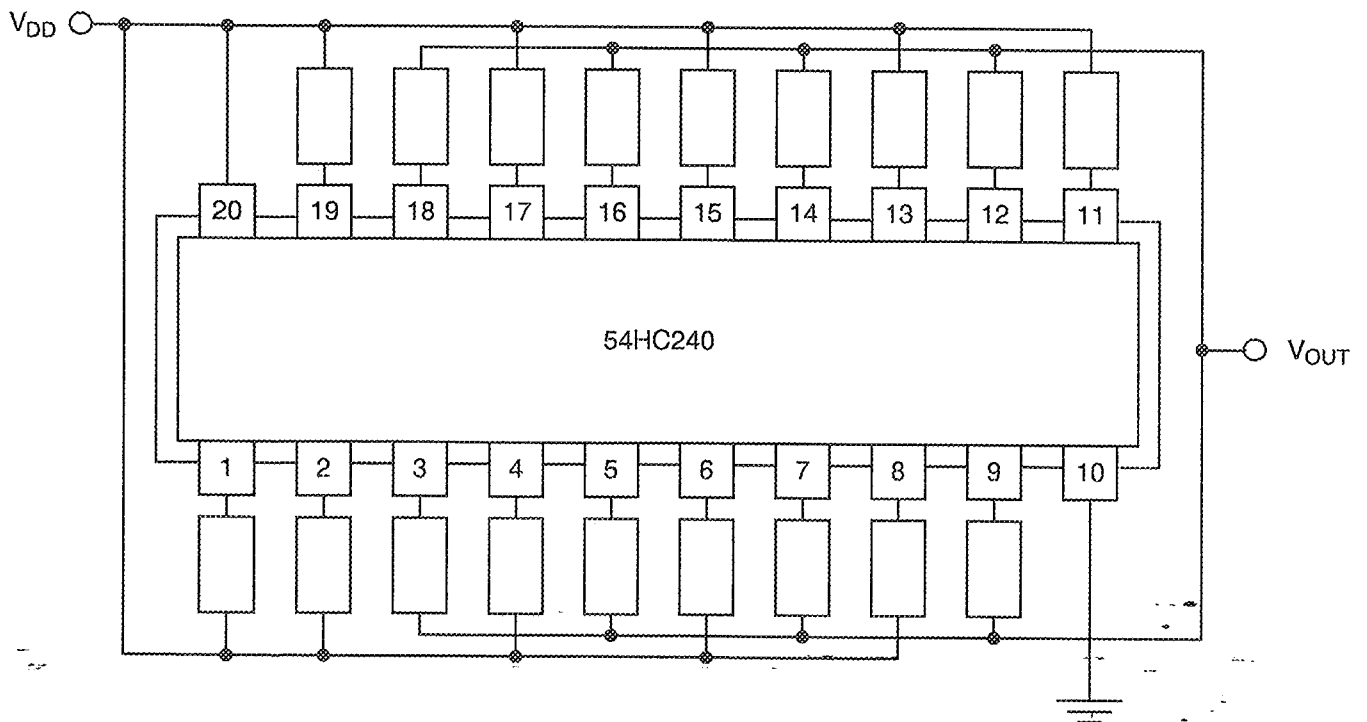
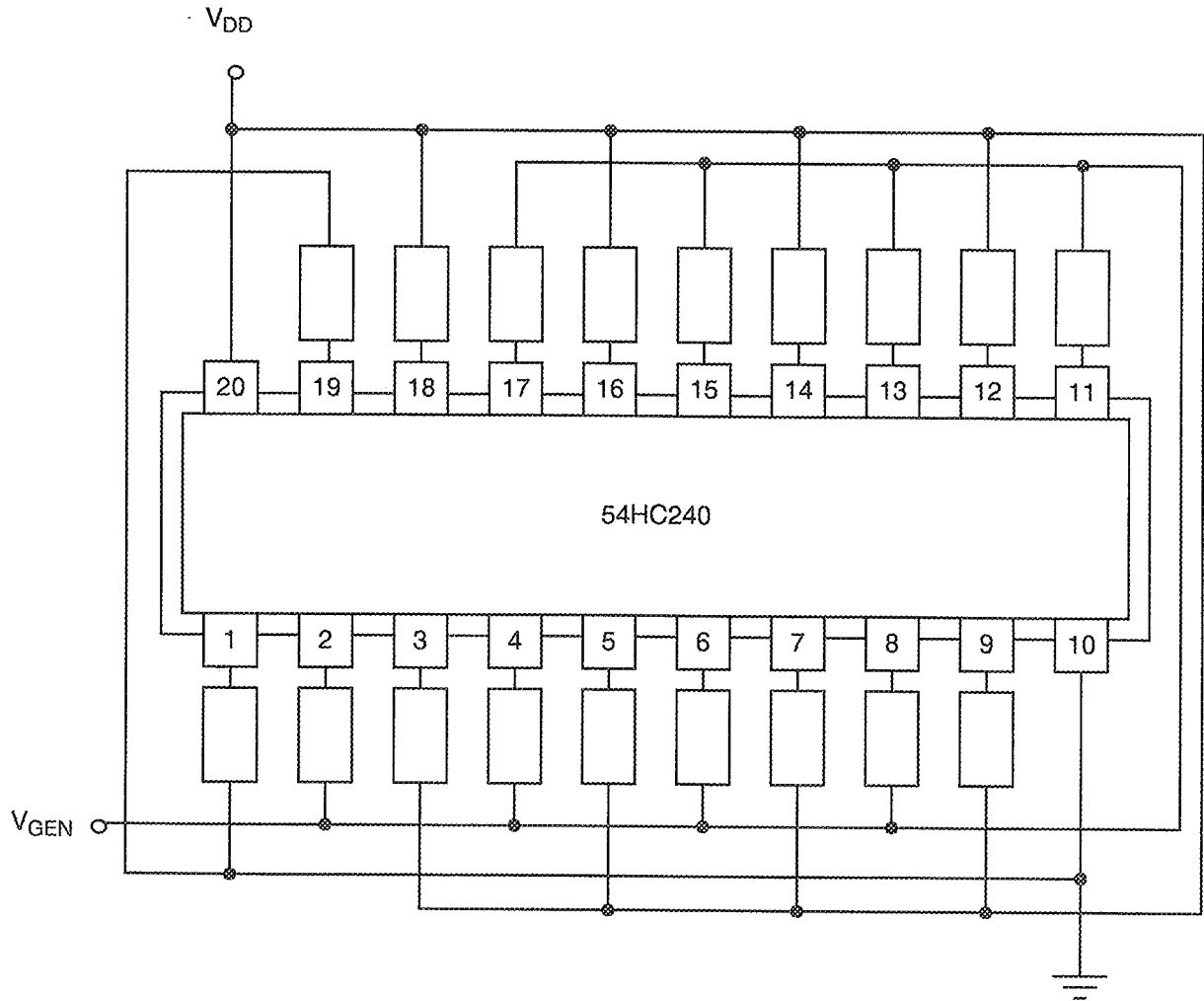



FIGURE 5(c) - ELECTRICAL CIRCUIT FOR POWER BURN-IN AND OPERATING LIFE TEST





4.8 ENVIRONMENTAL AND ENDURANCE TESTS (CHARTS IV AND V OF ESA/SCC GENERIC SPECIFICATION NO. 9000)

4.8.1 Electrical Measurements on Completion of Environmental Tests

The parameters to be measured on completion of environmental tests are scheduled in Table 6. Unless otherwise stated, the measurements shall be performed at $T_{amb} = +22 \pm 3 \text{ }^\circ\text{C}$.

4.8.2 Electrical Measurements at Intermediate Points during Endurance Tests

The parameters to be measured at intermediate points during endurance tests are as scheduled in Table 6 of this specification. Unless otherwise stated, the measurements shall be performed at $T_{amb} = +22 \pm 3 \text{ }^\circ\text{C}$.

4.8.3 Electrical Measurements on Completion of Endurance Tests

The parameters to be measured on completion of endurance testing are as scheduled in Table 6 of this specification. Unless otherwise stated, the measurements shall be performed at $T_{amb} = +22 \pm 3 \text{ }^\circ\text{C}$.

4.8.4 Conditions for Operating Life Tests

The requirements for operating life testing are specified in Section 9 of ESA/SCC Generic Specification No. 9000. The conditions for operating life testing shall be as specified in Table 5(c) of this specification.

4.8.5 Electrical Circuits for Operating Life Tests

Circuits for use in performing the operating life tests are shown in Figure 5(c) of this specification.

4.8.6 Conditions for High Temperature Storage Test

The requirements for the high temperature storage test are specified in ESA/SCC Generic Specification No. 9000. The temperature to be applied shall be the maximum storage temperature specified in Table 1(b) of this specification.

4.9 TOTAL DOSE IRRADIATION TESTING

4.9.1 Application

If specified in Para. 4.2.1 of this specification, total dose irradiation testing shall be performed in accordance with the requirements of ESA/SCC Basic Specification No. 22900.

4.9.2 Bias Conditions

Continuous bias shall be applied during irradiation testing as shown in Figure 6 of this specification.

4.9.3 Electrical Measurements

The parameters to be measured prior to irradiation exposure are scheduled in Table 2 of this specification. Only devices which meet the requirements of Table 2 shall be included in the test sample.

The parameters to be measured during and on completion of irradiation testing are scheduled in Table 7 of this specification.

**TABLE 6 - ELECTRICAL MEASUREMENTS ON COMPLETION OF ENVIRONMENTAL TESTS AND AT INTERMEDIATE POINTS AND ON COMPLETION OF ENDURANCE TESTING**

NO.	CHARACTERISTICS	SYMBOL	SPEC. AND/OR TEST METHOD	TEST CONDITIONS	CHANGE LIMITS (Δ) (NOTE 1)	ABSOLUTE		UNIT
						MIN	MAX	
1	Functional Test 1	-	As per Table 2	As per Table 2	-	-	-	-
2	Functional Test 2	-	As per Table 2	As per Table 2	-	-	-	-
3	Functional Test 3	-	As per Table 2	As per Table 2	-	-	-	-
4 to 7	Quiescent Current	I_{DD}	As per Table 2	As per Table 2	± 0.12	-	0.4	μA
8 to 17	Input Current Low Level	I_{IL}	As per Table 2	As per Table 2	± 20	-	- 50	nA
18 to 27	Input Current High Level	I_{IH}	As per Table 2	As per Table 2	± 20	-	50	nA
52 to 59	Output Voltage Low Level 4	V_{OL4}	As per Table 2	As per Table 2	± 0.026	-	0.26	V
60 to 67	Output Voltage Low Level 5	V_{OL5}	As per Table 2	As per Table 2	± 0.026	-	0.26	V
92 to 99	Output Voltage High Level 4	V_{OH4}	As per Table 2	As per Table 2	± 0.2	3.98	-	V
100 to 107	Output Voltage High Level 5	V_{OH5}	As per Table 2	As per Table 2	± 0.2	5.48	-	V
108	Threshold Voltage N-Channel	V_{THN}	As per Table 2	As per Table 2	± 0.3	-0.45	- 1.45	V
109	Threshold Voltage P-Channel	V_{THP}	As per Table 2	As per Table 2	± 0.3	0.45	1.35	V
130 to 137	Output Leakage Current Third State (Low Level Applied)	I_{OZL}	As per Table 2	As per Table 2	± 0.2	-	- 0.5	μA
138 to 145	Output Leakage Current Third State (High Level Applied)	I_{OZH}	As per Table 2	As per Table 2	± 0.2	-	0.5	μA

NOTES

1. The change limits (Δ) are applicable to the Operating Life test only. The change in parameters between initial and end point measurements shall not exceed the limits given. In addition, the absolute limits shall not be exceeded.



FIGURE 6 - BIAS CONDITIONS FOR IRRADIATION TESTING

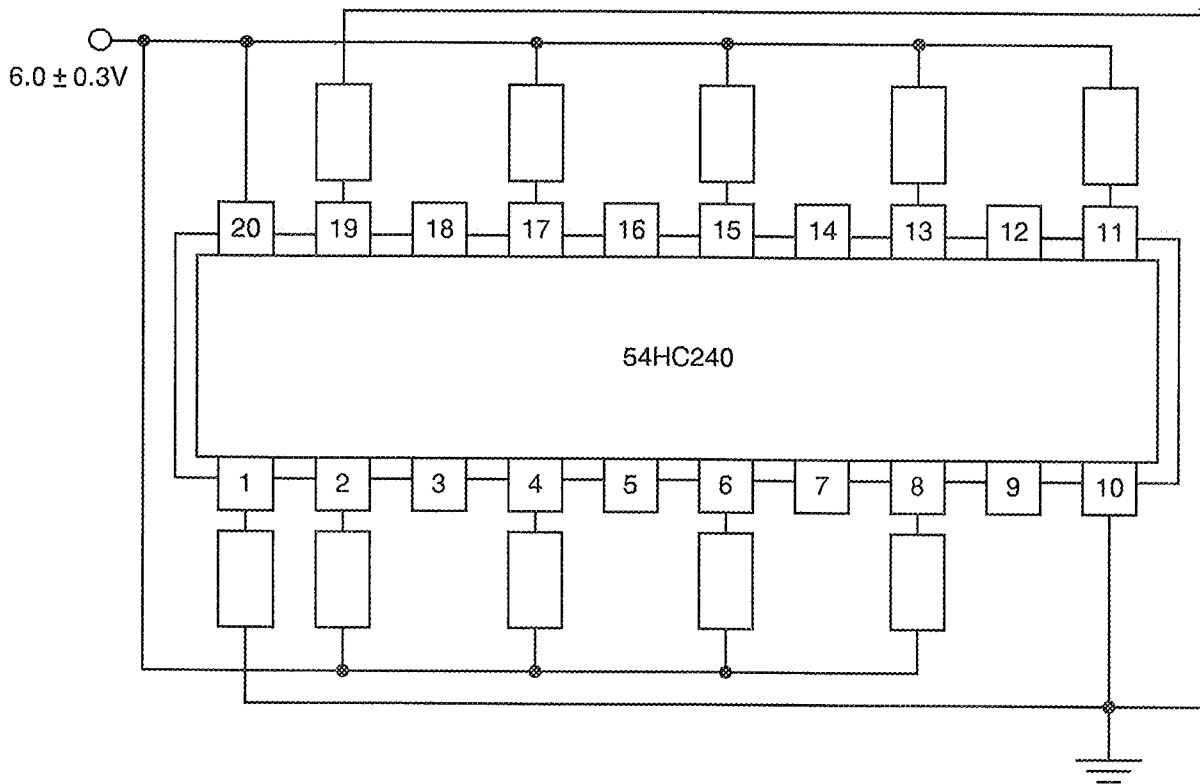

NOTES

1. Input Protection Resistor = 680Ω min. to 47kΩ max.



TABLE 7 - ELECTRICAL MEASUREMENTS DURING AND ON COMPLETION OF IRRADIATION TESTING

NO.	CHARACTERISTICS	SYMBOL	SPEC. AND/OR TEST METHOD	TEST CONDITIONS	CHANGE LIMITS (Δ)	ABSOLUTE		UNIT
						MIN	MAX	
4 to 7	Quiescent Current	I_{DD}	As per Table 2	As per Table 2	-	-	40	μA
108	Threshold Voltage N-Channel	V_{THN}	As per Table 2	As per Table 2	± 0.6	-0.4	-1.5	V
109	Threshold Voltage P-Channel	V_{THP}	As per Table 2	As per Table 2	± 0.6	0.4	1.4	V

APPENDIX 'A'

AGREED DEVIATIONS FOR TEXAS INSTRUMENTS (F)

ITEMS AFFECTED	DESCRIPTION OF DEVIATIONS
Para. 4.2.3	Para. 9.9.2, "Electrical Measurements at High and Low Temperatures": Only a test result summary, based on go-no-go- tests and presented in histogram form is required.



ESASCC

ESA/SCC Detail Specification
No. 9401/034

Rev. 'B'

PAGE 44

ISSUE 1

APPENDIX 'B'

Page 1 of 1

AGREED DEVIATIONS FOR STMICROELECTRONICS (F)

ITEMS AFFECTED	DESCRIPTION OF DEVIATIONS
Para. 4.2.3	Para. 7.1.1(b): Power Burn-in test is performed using STMicroelectronics Specification Ref.: 0019255. Para. 9.23, High Temperature Reverse Bias Burn-in: The temperature limits of MIL-STD-883, Para. 4.5.8(c) may be used. Para. 9.24, Power Burn-in: The temperature limits of MIL-STD-883, Para. 4.5.8(c) may be used.
Para. 4.2.4	Para. 9.21.1, Operating Life During Qualification Testing: The temperature limits of MIL-STD-883, Para. 4.5.8(c) may be used.
Para. 4.2.5	Para. 9.21.2, Operating Life During Lot Acceptance Testing: The temperature limits of MIL-STD-883, Para. 4.5.8(c) may be used.