



# TOTAL DOSE RADIATION TEST REPORT

**Part Type : BUZ341**

**Package : TO-218AA**

**N-Channel Power MOSFET**

**SIEMENS**

**Report Reference : ESA\_QCA990908T\_C**

**Issue : 01**

**Date : July 1<sup>st</sup> 1999**

ESA Contract No 13413/98/NL/MV dated 25/01/99

European Space Agency Contract Report

The work described in this report was done under ESA contract.  
Responsibility for the contents resides in the author or organization that prepared it

ESTEC Technical Officer: R. Harboe Sorensen

<b>Hirex reference :</b>	HRX/99.4567	Issue : 01	Date :	July 1 <sup>st</sup> 1999
<b>Written by :</b>	J.F. PASCAL		Date :	
<b>Approved by :</b>	F.X GUERRE		Date :	

**TOTAL DOSE RADIATION TEST REPORT**  
**on**  
**Siemens BUZ341 N-Channel Power Mosfet.**

**TABLE OF CONTENTS**

<b>1</b>	<b>ABSTRACT.....</b>	<b>3</b>
<b>2</b>	<b>INTRODUCTION .....</b>	<b>4</b>
<b>3</b>	<b>APPLICABLE AND REFERENCE DOCUMENTS .....</b>	<b>4</b>
3.1	APPLICABLE DOCUMENTS.....	4
3.2	REFERENCE DOCUMENTS .....	4
<b>4</b>	<b>TEST SAMPLES.....</b>	<b>4</b>
<b>5</b>	<b>EXPERIMENTAL CONDITIONS .....</b>	<b>5</b>
5.1	RADIATION SOURCE DOSE RATE AND ANNEALING .....	5
5.2	BIAS DURING DOSE EXPOSURES AND MEASUREMENTS CONDITIONS.....	5
5.2.1	Bias conditions.....	5
5.2.2	Electrical Measurements .....	6
<b>6</b>	<b>TEST SUMMARY .....</b>	<b>8</b>
<b>7</b>	<b>TEST RESULTS .....</b>	<b>9</b>
<b>8</b>	<b>CONCLUSION .....</b>	<b>21</b>
	<b>ANNEX 1 : BUZ341 DATA SHEET .....</b>	<b>22</b>

<b>HIREX Engineering</b>	<b>Total Dose Test Report</b>		Réf. : HRX/99.4567 Issue : 01
Part Type :	BUZ341	Manufacturer :	Siemens

## 1 Abstract

Under ESA/ESTEC contract n° 13413/98/NL/MV covering "Radiation Evaluation of Power MOSFET Devices from Different European Manufacturers", a large number of commercial Power MOSFET device types were radiation assessed. Results from these assessments, primarily focused on the radiation sensitivity of the MOSFETs to Total Ionizing Dose (TID) and Single Event Effects (SEE), are reported in individual TID and SEE reports. Below summary table list manufacturer and evaluated types, and give references to the various reports issued.

<b>Manufacturer</b>	<b>Type</b>	<b>TID Report</b>	<b>SEE Report</b>
Philips	PHP50N06T	ESA_QCA990901T_C	ESA_QCA990901S_C
Philips	BUK456-200A	ESA_QCA990902T_C	ESA_QCA990902S_C
Motorola	MTP50N06VL	ESA_QCA990903T_C	
Motorola	MTW32N20E	ESA_QCA990904T_C	
Motorola	MTP50N06V	ESA_QCA990905T_C	
Siemens	BUZ100S	ESA_QCA990906T_C	ESA_QCA990906S_C
Siemens	BUZ100SL	ESA_QCA990907T_C	ESA_QCA990907S_C
Siemens	BUZ341	ESA_QCA990908T_C	ESA_QCA990908S_C
SGS-Thomson	SP60	ESA_QCA990909T_C	ESA_QCA990909S_C
SGS-Thomson	SP100V	ESA_QCA9909010T_C	ESA_QCA9909010S_C
SGS-Thomson	SP200V	ESA_QCA9909011T_C	ESA_QCA9909011S_C
Siemens	SPP1N60S5	ESA_QCA9909012T_C	ESA_QCA9909012S_C
Philips	BUK7508-55	ESA_QCA9909013T_C	ESA_QCA9909013S_C
Harris	HUF75639P3	ESA_QCA9909014T_C	ESA_QCA9909014S_C

<b>HIREX Engineering</b>	<b>Total Dose Test Report</b>		Réf. : HRX/99.4567 Issue : 01
Part Type :	BUZ341	Manufacturer :	Siemens

## 2 Introduction

A total dose radiation evaluation test of the SIEMENS BUZ341 N-Channel Power Mosfet has been performed with an accumulated dose of about 37 Krad(Si) at a dose rate of 75 rad(Si)/hour, in response to European Space Agency contract reference : 13413/98/NL/MV.

The purpose of this test was to evaluate total dose withstanding of this component, to investigate its suitability for being used in space applications. This test was conducted on commercial samples provided by ESTEC.

Test has been performed in accordance with Hirex proposal HRX/98.3475 issue 01.

A complete set of electrical measurements together with graphical representation of measured parameters with respect to total dose received, are provided for all samples.

SEE results for this device type can be found in SEE radiation test report: ESA\_QCA990908S\_C

## 3 Applicable and Reference Documents

### 3.1 Applicable Documents

- ESA/SCC Basic specification N° 22900 issue 4
- Siemens datasheet (see Annex)
- Hirex Engineering proposal: HRX/98.3475 issue 01.

### 3.2 Reference Documents

- MIL-STD-883: test methods and procedures for microcircuits

## 4 Test Samples

11 samples of the BUZ341 device were tested (2 groups of 5 + 1 control sample). The samples were serialized before the radiation test as indicated in the following table.

Serial Number	Allocation
1	Control
2	Bias 1
3	Bias 1
4	Bias 1
5	Bias 1
6	Bias 1
7	Bias 2
8	Bias 2
9	Bias 2
10	Bias 2
11	Bias 2

Identification of the BUZ341 is given below:

<b>Part Number:</b>	BUZ341	<b>Mask Set:</b>	NA
<b>Top Marking:</b>	BUZ341 Z703	<b>Chip Marking:</b>	NA
<b>Diffusion Lot:</b>	NA	<b>Wafer #:</b>	NA
<b>Date Code:</b>	Z703	<b>Project:</b>	Not defined

<b>HIREX Engineering</b>	<b>Total Dose Test Report</b>		Réf. : HRX/99.4567 Issue : 01
Part Type :	BUZ341	Manufacturer :	Siemens

## 5 Experimental Conditions

### 5.1 Radiation Source Dose Rate and Annealing

The dose exposures were performed at CERT-ONERA. In this irradiation facility, a Cobalt 60 source is used with the possibility to vary the dose rate by simply adjusting the distance to the source. The irradiation conditions used for this test are provided in the following table:

Irradiation Steps krads	Dose rate krads/h	Annealing steps hours	Temperature °C
0			
3.85	0,075		25
7.35	0,075		25
13.95	0,075		25
19.65	0,075		25
24.65	0,075		25
29.85	0,075		25
36.85	0,075	0	25
		24	25
		192	100

### 5.2 Bias during Dose Exposures and Measurements conditions

#### 5.2.1 Bias conditions

During exposures dedicated test boards were used mounted on a special board-holder made for irradiation. The test board allowed to bias the devices in accordance with the electrical circuit provided in Figure 1. Two bias conditions were used so called Bias 1 and Bias 2.

Bias 1 corresponds to a gate stress of  $V_{GS}$  equals 12 Volts. Bias 2 corresponds to drain to source stress equals 80% of BVDSS.

During annealing steps the same stress conditions were applied at room and 100°C temperatures respectively.

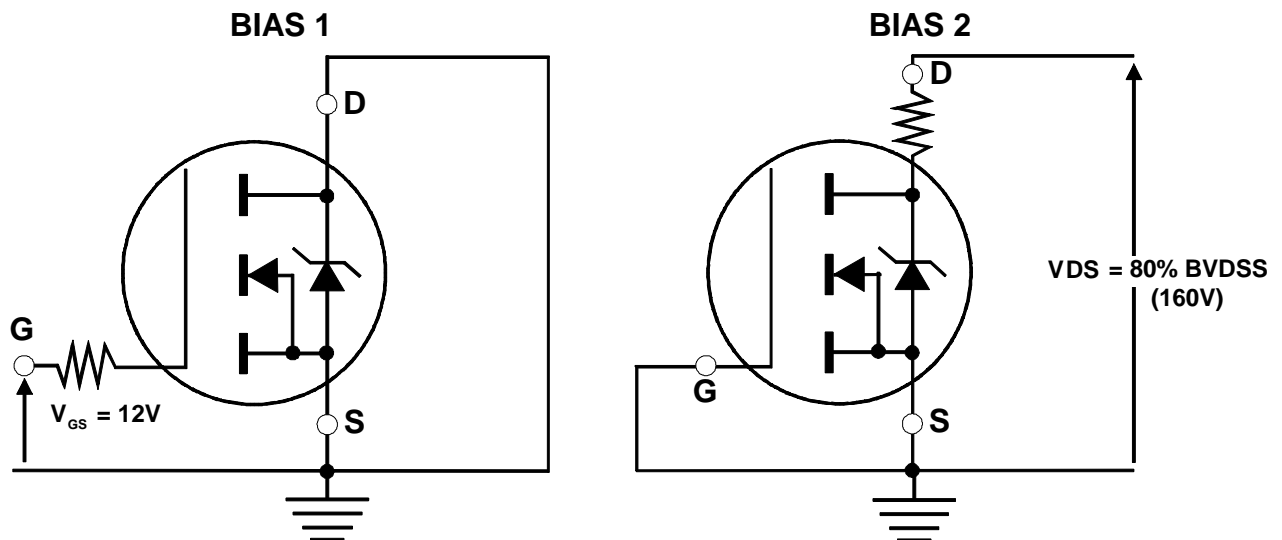

Figure 1 : Bias Conditions during Irradiation Exposures and Annealing

<b>HIREX Engineering</b>	<b>Total Dose Test Report</b>		Réf. : HRX/99.4567 Issue : 01
Part Type :	BUZ341	Manufacturer :	Siemens

### 5.2.2 Electrical Measurements

Mosfet transistor test program principle is provided in Figure 2. Due to the great number of samples to be measured ( test campaign was conducted on 14 part types at the same time) and the time interval constraints required for performing measurements after each exposure and annealing step, It was decided to automate low power and high power measurements.

Two instruments were used to cover low power and high power measurements respectively. HP4142B was used for breakdown voltage, gate and drain leakage currents, and threshold voltage measurements.

Tektronix TEK371 high power curve tracer was used for  $R_{DS(ON)}$  measurements.

A dedicated test fixture was designed to ensure proper switching of instruments. In addition a faraday cup was used to ensure optimum conditions for low level measurements.

Test program has been written in Visual Basic on a PC computer. GPIB commands were sent to each instrument via IEEE bus, in order to measure a given parameter with specified conditions. Results were automatically loaded in an Excel worksheet and compared in real time to specification limits. This allowed for real time data analysis in particular when failures were recorded.

**Figure 2 : Mosfet transistor test program principle**

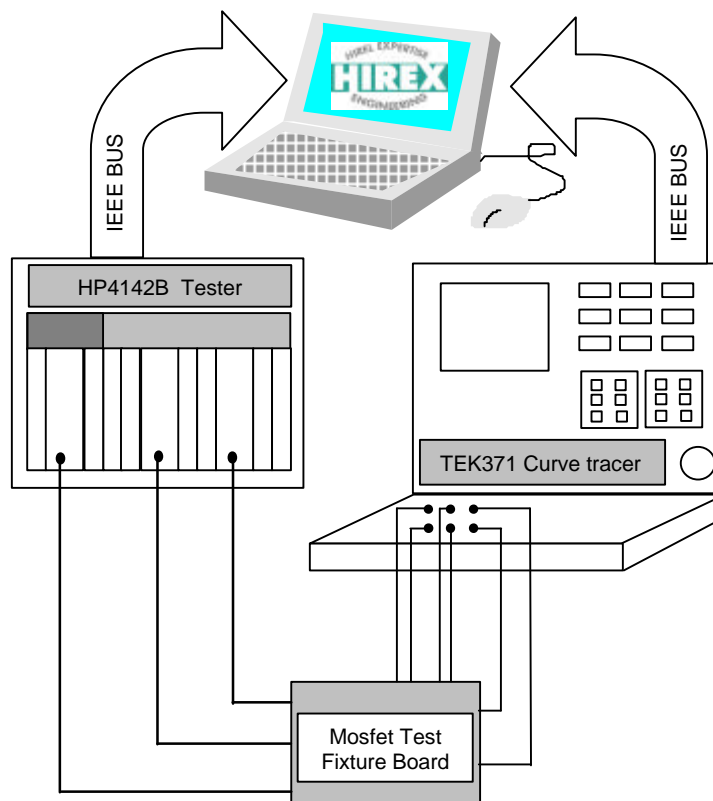

<b>HIREX Engineering</b>	<b>Total Dose Test Report</b>		Réf. : HRX/99.4567 Issue : 01
Part Type :	BUZ341	Manufacturer :	Siemens

Electrical parameters test conditions and limits used for performing this test are given in the following table.

<b>Symbol</b>	<b>Test Parameter</b>	<b>Test Conditions</b>	<b>Min limit</b>	<b>Max limit</b>	<b>Unit</b>
BVDSS	Drain to Source breakdown voltage	VGS=0V, ID=0.25mA	200		V
VGSTH	Gate to Source threshold voltage	VDS>=VGS, ID=1mA	2.1	4	V
+IGSS	Positive Gate Source leakage current	VGS=+20V, VDS=0V		100	nA
-IGSS	Negative Gate Source leakage current	VGS=-20V, VDS=0V		100	nA
IDSS	Drain current	VGS=0V, VDS=200V		1	μA
RDSON	Static drain to source on-state resistance	VGS=10V, ID=21A		0.07	Ohm

**Table 1 : Measured electrical parameters**

<b>HIREX Engineering</b>	<b>Total Dose Test Report</b>		Réf. : HRX/99.4567 Issue : 01
Part Type :	BUZ341	Manufacturer :	Siemens

## 6 Test Summary

A Total Ionizing Dose assessment was carried out by Hirex Engineering under ESA contract on the SIEMENS BUZ341 N-Channel Power Mosfet.

2 groups of 5 samples each plus one control sample were used during testing. The first group was exposed to radiation using Bias 1 conditions corresponding to a gate stress of the devices. The second group of 5 samples was exposed to radiation using Bias 2 conditions corresponding to drain to source stress of the devices, equals 80% of BVDSS (160 Volts).

Based on the analysis of the results, the tolerances of this component and main conclusion are provided below.

**Parametric Tolerance Level ( $\geq$ Krad) - Bias 1:** 19.65

**Parametric Tolerance Level ( $\geq$ Krad) - Bias 2:** 3.85

Parametric tolerance level represents the last cumulative exposure at which no samples failed any test

### Main conclusion:

BVDSS under Bias 2 conditions is marginally out of specification at 3.85 Krad(Si), continues to degrade subsequently, and does not completely recover during final steps.  
 BVDSS under Bias 1 conditions is out of specification at 24.65 Krad(Si) for one sample. Other samples are beyond specification limit at 29,85 Krad(Si), and a recovery is observed after 168 hours annealing.  
 IDSS, under Bias 2 conditions, increases significantly at low dose (3.85 Krad(Si)), continues to degrade up to the compliance value. No recovery is noted during annealing.  
 A rebound effect has been observed on  $R_{ds,on}$  under Bias 2 conditions, during the last annealing step. This parameter reaching the limit of its specification.



<b>HIREX Engineering</b>	<b>Total Dose Test Report</b>			Réf. : HRX/99.4567 Issue : 01
Part Type :	BUZ341	Manufacturer :	Siemens	

## 7 Test Results

Test results including tables and graphics are provided in this section for each measured parameter. To allow easy reading of data, each parameter is plotted twice, one for the first bias condition: Bias 1 and one for the second condition: Bias 2.

**Parameter: Drain to source breakdown voltage: BVDSS-Bias1 VGS=0V, ID=0.25mA**

Unit= V

Spec limit min: 200

Spec limits are represented in bold lines on the graphic.

Test Step	Initial	3,85 krad	7,35 krad	13,95 krad	19,65 krad	24,65 krad	29,85 krad
Serial #							
1 Ref.	2,112E +02	2,109E +02	2,129E +02	2,114E +02	2,133E +02	2,110E +02	2,108E +02
2	2,144E +02	2,144E +02	2,168E +02	2,144E +02	2,147E +02	2,053E +02	1,993E +02
3	2,181E +02	2,180E +02	2,205E +02	2,180E +02	2,175E +02	2,102E +02	2,001E +02
4	2,171E +02	2,170E +02	2,193E +02	2,169E +02	2,172E +02	2,069E +02	2,009E +02
5	2,067E +02	2,066E +02	2,089E +02	2,066E +02	2,070E +02	1,985E +02	1,948E +02
6	2,116E +02	2,114E +02	2,138E +02	2,114E +02	2,117E +02	2,038E +02	1,990E +02
Statistics							
Min	2,067E +02	2,066E +02	2,089E +02	2,066E +02	2,069E +02	1,985E +02	1,948E +02
Max	2,181E +02	2,180E +02	2,205E +02	2,179E +02	2,175E +02	2,102E +02	2,009E +02
Mean	2,136E +02	2,135E +02	2,159E +02	2,134E +02	2,136E +02	2,049E +02	1,988E +02
Sigma	4,618E +00	4,634E +00	4,655E +00	4,595E +00	4,390E +00	4,301E +00	2,391E +00

Test Step	36,85 krad	24 hours	192 hours
Serial #			
1 Ref.	2,132E +02	2,113E +02	2,108E +02
2	1,984E +02	2,028E +02	2,140E +02
3	2,020E +02	2,087E +02	2,176E +02
4	2,020E +02	2,077E +02	2,167E +02
5	1,976E +02	2,039E +02	2,063E +02
6	1,988E +02	2,073E +02	2,110E +02
Statistics			
Min	1,976E +02	2,028E +02	2,063E +02
Max	2,020E +02	2,086E +02	2,176E +02
Mean	1,998E +02	2,061E +02	2,131E +02
Sigma	2,075E +00	2,544E +00	4,595E +00

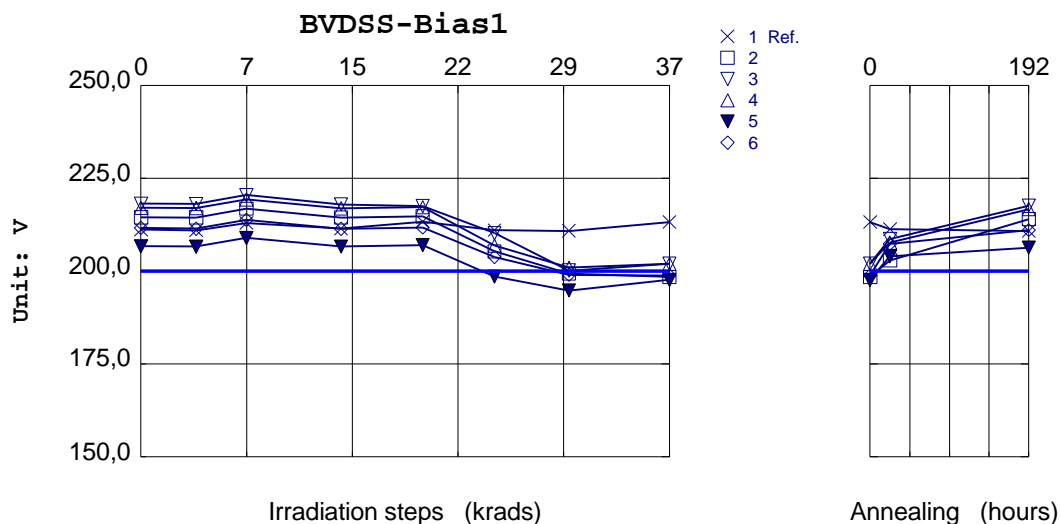

<b>HIREX Engineering</b>	<b>Total Dose Test Report</b>			Réf. : HRX/99.4567 Issue : 01
Part Type :	BUZ341	Manufacturer :	Siemens	

**Parameter: Drain to source breakdown voltage: BVDSS-Bias2 VGS=0V, ID=0.25mA**

Unit= V

Spec limit min: 200

Spec limits are represented in bold lines on the graphic.

Test Step	Initial	3,85 krad	7,35 krad	13,95 krad	19,65 krad	24,65 krad	29,85 krad
Serial #							
1 Ref.	2,112E +02	2,109E +02	2,129E +02	2,114E +02	2,133E +02	2,110E +02	2,108E +02
7	2,153E +02	2,032E +02	1,468E +02	1,012E +02	9,883E +01	1,015E +02	1,028E +02
8	2,200E +02	2,081E +02	1,496E +02	1,011E +02	1,012E +02	1,028E +02	1,049E +02
9	2,070E +02	1,973E +02	1,431E +02	9,831E +01	9,715E +01	1,002E +02	1,015E +02
10	2,201E +02	1,968E +02	1,332E +02	9,574E +01	9,691E +01	1,003E +02	1,032E +02
11	2,137E +02	1,949E +02	1,345E +02	9,589E +01	9,692E +01	1,003E +02	1,029E +02
Statistics							
Min	2,069E +02	1,949E +02	1,332E +02	9,574E +01	9,691E +01	1,002E +02	1,015E +02
Max	2,201E +02	2,081E +02	1,496E +02	1,012E +02	1,012E +02	1,028E +02	1,049E +02
Mean	2,152E +02	2,000E +02	1,414E +02	9,845E +01	9,821E +01	1,010E +02	1,030E +02
Sigma	5,407E +00	5,449E +00	7,332E +00	2,669E +00	1,866E +00	1,131E +00	1,200E +00

Test Step	36,85 krad	24 hours	192 hours
Serial #			
1 Ref.	2,132E +02	2,113E +02	2,108E +02
7	1,038E +02	1,150E +02	1,741E +02
8	1,051E +02	1,168E +02	1,685E +02
9	1,023E +02	1,142E +02	1,572E +02
10	1,051E +02	1,164E +02	1,625E +02
11	1,044E +02	1,161E +02	1,617E +02
Statistics			
Min	1,023E +02	1,142E +02	1,572E +02
Max	1,051E +02	1,168E +02	1,741E +02
Mean	1,041E +02	1,157E +02	1,648E +02
Sigma	1,150E +00	1,050E +00	6,562E +00

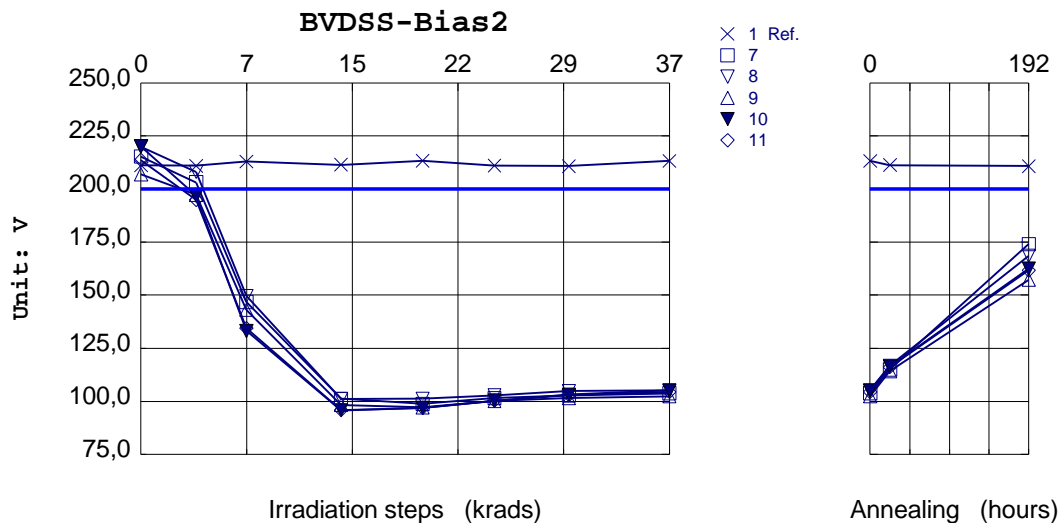

<b>HIREX Engineering</b>	<b>Total Dose Test Report</b>			Réf. : HRX/99.4567 Issue : 01
Part Type :	BUZ341	Manufacturer :	Siemens	

Parameter: Gate to source threshold voltage: VGSTH-Bias1 VDS>=VGS, ID=1mA

Unit= V

Spec limit max: 4

Spec limit min: 2.1

Spec limits are represented in bold lines on the graphic.

Test Step	Initial	3,85 krad	7,35 krad	13,95 krad	19,65 krad	24,65 krad	29,85 krad
Serial #							
1 Ref.	3,228E +00	3,244E +00	3,258E +00	3,213E +00	3,254E +00	3,244E +00	3,256E +00
2	3,284E +00	3,110E +00	2,956E +00	2,703E +00	2,493E +00	2,278E +00	2,107E +00
3	3,248E +00	3,091E +00	2,910E +00	2,644E +00	2,368E +00	2,210E +00	2,028E +00
4	3,231E +00	3,044E +00	2,875E +00	2,595E +00	2,345E +00	2,137E +00	1,957E +00
5	3,294E +00	3,122E +00	2,962E +00	2,663E +00	2,386E +00	2,210E +00	2,036E +00
6	3,235E +00	3,084E +00	2,907E +00	2,599E +00	2,333E +00	2,126E +00	1,942E +00
Statistics							
Min	3,231E +00	3,044E +00	2,875E +00	2,595E +00	2,333E +00	2,126E +00	1,942E +00
Max	3,294E +00	3,122E +00	2,962E +00	2,703E +00	2,493E +00	2,278E +00	2,107E +00
Mean	3,258E +00	3,090E +00	2,922E +00	2,641E +00	2,385E +00	2,192E +00	2,014E +00
Sigma	2,875E -02	3,019E -02	3,656E -02	4,526E -02	6,379E -02	6,206E -02	6,658E -02

Test Step	36,85 krad	24 hours	192 hours
Serial #			
1 Ref.	3,254E +00	3,199E +00	3,251E +00
2	1,913E +00	1,882E +00	2,349E +00
3	1,791E +00	1,775E +00	2,243E +00
4	1,759E +00	1,725E +00	2,223E +00
5	1,811E +00	1,797E +00	2,253E +00
6	1,756E +00	1,719E +00	2,227E +00
Statistics			
Min	1,756E +00	1,719E +00	2,223E +00
Max	1,913E +00	1,882E +00	2,349E +00
Mean	1,806E +00	1,780E +00	2,259E +00
Sigma	6,407E -02	6,586E -02	5,165E -02

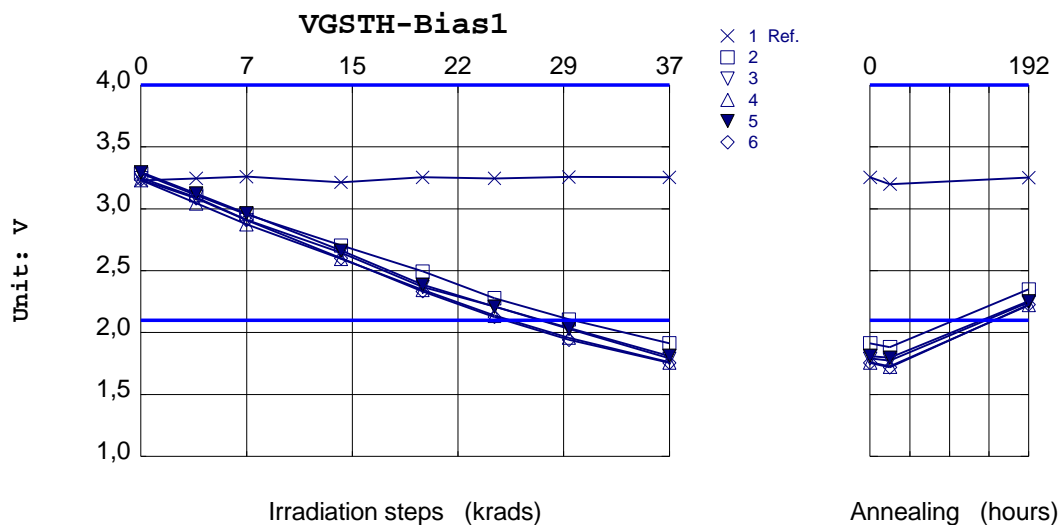

<b>HIREX Engineering</b>	<b>Total Dose Test Report</b>			Réf. : HRX/99.4567 Issue : 01
Part Type :	BUZ341	Manufacturer :	Siemens	

**Parameter: Gate to source threshold voltage: VGSTH-Bias2 VDS>=VGS, ID=1mA**

Unit= V

Spec limit max: 4

Spec limit min: 2.1

Spec limits are represented in bold lines on the graphic.

Test Step	Initial	3,85 krad	7,35 krad	13,95 krad	19,65 krad	24,65 krad	29,85 krad
Serial #							
1 Ref.	3,228E +00	3,244E +00	3,258E +00	3,213E +00	3,254E +00	3,244E +00	3,256E +00
7	3,194E +00	2,908E +00	2,678E +00	2,242E +00	1,833E +00	1,593E +00	1,333E +00
8	3,277E +00	2,975E +00	2,760E +00	2,294E +00	1,928E +00	1,655E +00	1,436E +00
9	3,257E +00	2,952E +00	2,695E +00	2,223E +00	1,778E +00	1,490E +00	1,192E +00
10	3,292E +00	2,956E +00	2,666E +00	2,151E +00	1,704E +00	1,386E +00	1,111E +00
11	3,262E +00	2,901E +00	2,626E +00	2,102E +00	1,656E +00	1,350E +00	1,075E +00
Statistics							
Min	3,194E +00	2,901E +00	2,626E +00	2,102E +00	1,656E +00	1,350E +00	1,075E +00
Max	3,292E +00	2,975E +00	2,760E +00	2,294E +00	1,928E +00	1,655E +00	1,436E +00
Mean	3,257E +00	2,938E +00	2,685E +00	2,202E +00	1,780E +00	1,495E +00	1,229E +00
Sigma	3,769E -02	3,218E -02	4,891E -02	7,612E -02	1,072E -01	1,305E -01	1,521E -01

Test Step	36,85 krad	24 hours	192 hours
Serial #			
1 Ref.	3,254E +00	3,199E +00	3,251E +00
7	1,049E +00	1,081E +00	3,543E +00
8	1,136E +00	1,158E +00	3,734E +00
9	8,123E -01	8,463E -01	3,737E +00
10	8,125E -01	8,469E -01	3,794E +00
11	7,517E -01	7,886E -01	3,759E +00
Statistics			
Min	7,517E -01	7,886E -01	3,543E +00
Max	1,136E +00	1,158E +00	3,794E +00
Mean	9,124E -01	9,442E -01	3,713E +00
Sigma	1,693E -01	1,641E -01	9,823E -02

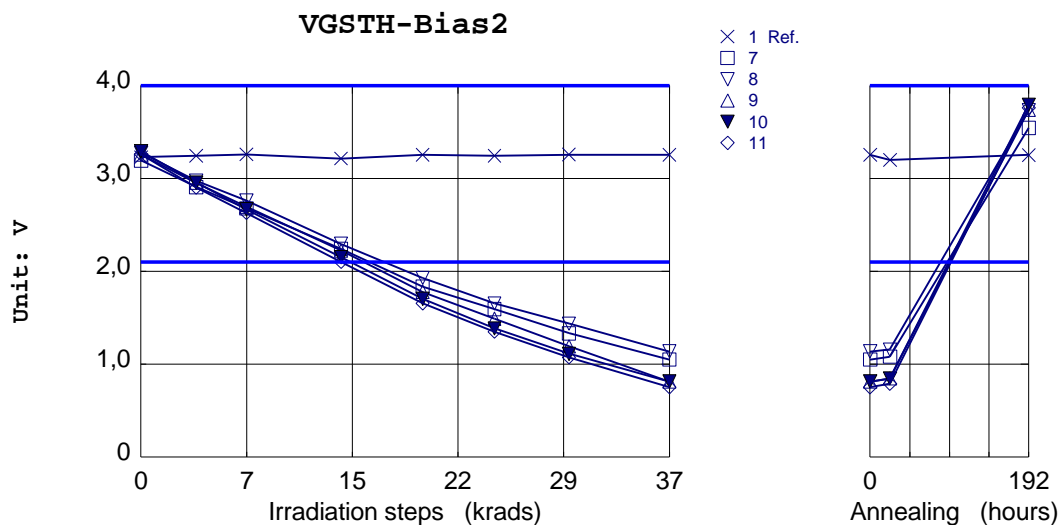

<b>HIREX Engineering</b>	<b>Total Dose Test Report</b>			Réf. : HRX/99.4567
				Issue : 01
Part Type :	BUZ341	Manufacturer :	Siemens	

**Parameter: Positive Gate source leakage current: +IGSS-Bias1 VGS=+20V, VDS=0V**

Unit= A

Spec limit max: 100E-9

Spec limits are represented in bold lines on the graphic.

Test Step	Initial	3,85 krad	7,35 krad	13,95 krad	19,65 krad	24,65 krad	29,85 krad
Serial #							
1 Ref.	1,238E -10	1,412E -10	1,284E -10	1,123E -10	1,170E -10	1,298E -10	1,324E -10
2	1,389E -10	1,468E -10	9,034E -11	1,301E -10	9,884E -11	1,196E -10	7,854E -11
3	1,071E -10	1,123E -10	7,974E -11	1,018E -10	6,036E -11	1,291E -10	3,966E -11
4	1,465E -10	1,091E -10	9,234E -11	1,195E -10	6,000E -11	1,181E -10	9,148E -11
5	9,128E -11	1,655E -10	6,742E -11	1,400E -10	9,644E -11	1,221E -10	1,165E -10
6	1,049E -10	1,516E -10	1,039E -10	1,389E -10	1,062E -10	1,097E -10	1,218E -10
Statistics							
Min	9,128E -11	1,091E -10	6,742E -11	1,018E -10	6,000E -11	1,097E -10	3,966E -11
Max	1,465E -10	1,655E -10	1,039E -10	1,400E -10	1,062E -10	1,291E -10	1,218E -10
Mean	1,177E -10	1,371E -10	8,676E -11	1,261E -10	8,438E -11	1,197E -10	8,960E -11
Sigma	2,374E -11	2,503E -11	1,381E -11	1,586E -11	2,238E -11	7,012E -12	3,310E -11

Test Step	36,85 krad	24 hours	192 hours
Serial #			
1 Ref.	1,324E -10	1,251E -10	1,396E -10
2	1,274E -10	7,566E -11	1,326E -10
3	1,286E -10	9,940E -11	1,566E -10
4	1,388E -10	1,126E -10	1,255E -10
5	1,222E -10	1,268E -10	1,295E -10
6	1,305E -10	1,225E -10	1,236E -10
Statistics			
Min	1,222E -10	7,566E -11	1,236E -10
Max	1,388E -10	1,268E -10	1,566E -10
Mean	1,295E -10	1,074E -10	1,335E -10
Sigma	6,053E -12	2,064E -11	1,336E -11

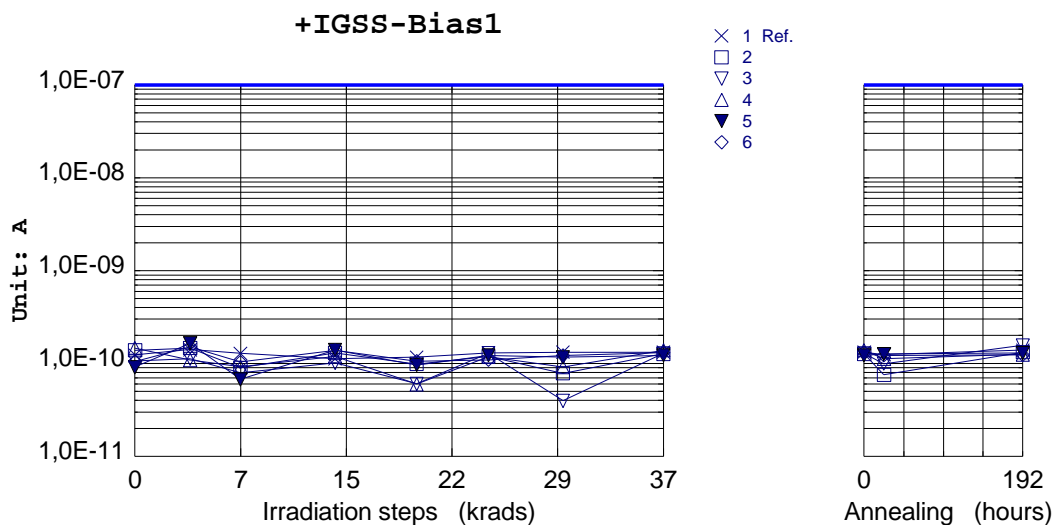

<b>HIREX Engineering</b>	<b>Total Dose Test Report</b>		Réf. : HRX/99.4567
			Issue : 01
Part Type :	BUZ341	Manufacturer :	Siemens

**Parameter: Positive Gate source leakage current: +IGSS-Bias2 VGS=+20V, VDS=0V**

Unit= A

Spec limit max: 100E-9

Spec limits are represented in bold lines on the graphic.

Test Step	Initial	3,85 krad	7,35 krad	13,95 krad	19,65 krad	24,65 krad	29,85 krad
Serial #							
1 Ref.	1,238E -10	1,412E -10	1,284E -10	1,123E -10	1,170E -10	1,298E -10	1,324E -10
7	1,255E -10	1,254E -10	8,726E -11	1,070E -10	7,776E -11	1,060E -10	8,574E -11
8	1,411E -10	1,038E -10	1,078E -10	1,273E -10	1,117E -10	1,172E -10	1,187E -10
9	1,275E -10	1,298E -10	8,932E -11	1,349E -10	1,006E -10	1,157E -10	9,594E -11
10	1,329E -10	1,318E -10	1,073E -10	1,606E -10	1,313E -10	1,054E -10	9,432E -11
11	1,353E -10	1,288E -10	7,298E -11	1,178E -10	9,604E -11	1,253E -10	9,158E -11
Statistics							
Min	1,255E -10	1,038E -10	7,298E -11	1,070E -10	7,776E -11	1,054E -10	8,574E -11
Max	1,411E -10	1,318E -10	1,078E -10	1,606E -10	1,313E -10	1,253E -10	1,187E -10
Mean	1,325E -10	1,239E -10	9,293E -11	1,295E -10	1,035E -10	1,139E -10	9,726E -11
Sigma	6,242E -12	1,149E -11	1,475E -11	2,029E -11	1,981E -11	8,363E -12	1,260E -11

Test Step	36,85 krad	24 hours	192 hours
Serial #			
1 Ref.	1,324E -10	1,251E -10	1,396E -10
7	9,994E -11	1,125E -10	1,183E -10
8	1,129E -10	9,096E -11	9,700E -11
9	1,244E -10	9,290E -11	1,221E -10
10	1,253E -10	1,195E -10	9,872E -11
11	1,422E -10	1,055E -10	1,434E -10
Statistics			
Min	9,994E -11	9,096E -11	9,700E -11
Max	1,422E -10	1,195E -10	1,434E -10
Mean	1,210E -10	1,043E -10	1,159E -10
Sigma	1,573E -11	1,231E -11	1,904E -11

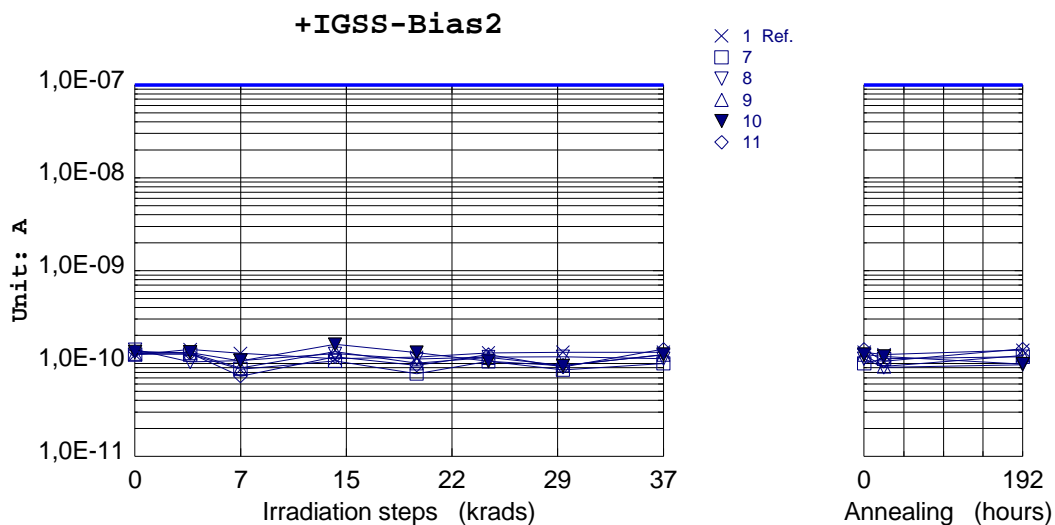

HIREX Engineering	Total Dose Test Report			Réf. : HRX/99.4567
				Issue : 01
Part Type :	BUZ341	Manufacturer :	Siemens	

Parameter: Negative Gate source leakage current: -IGSS-Bias1 VGS=-20V, VDS=0V

Unit= A

Spec limit max: 100E-9

Spec limits are represented in bold lines on the graphic.

Test Step	Initial	3,85 krad	7,35 krad	13,95 krad	19,65 krad	24,65 krad	29,85 krad
Serial #							
1 Ref.	2,214E -10	2,211E -10	2,109E -10	2,458E -10	2,009E -10	2,355E -10	2,226E -10
2	2,491E -10	2,090E -10	1,401E -10	2,224E -10	1,724E -10	1,601E -10	2,289E -10
3	2,482E -10	1,886E -10	1,659E -10	2,243E -10	2,028E -10	2,032E -10	2,672E -10
4	2,414E -10	1,827E -10	1,653E -10	2,003E -10	2,221E -10	1,627E -10	1,966E -10
5	2,484E -10	2,053E -10	1,922E -10	2,064E -10	1,837E -10	2,355E -10	2,167E -10
6	2,571E -10	2,382E -10	1,536E -10	1,991E -10	1,948E -10	1,282E -10	2,618E -10
Statistics							
Min	2,414E -10	1,827E -10	1,401E -10	1,991E -10	1,724E -10	1,282E -10	1,966E -10
Max	2,571E -10	2,382E -10	1,922E -10	2,243E -10	2,221E -10	2,355E -10	2,672E -10
Mean	2,488E -10	2,048E -10	1,634E -10	2,105E -10	1,952E -10	1,779E -10	2,342E -10
Sigma	5,568E -12	2,172E -11	1,921E -11	1,208E -11	1,893E -11	4,177E -11	3,000E -11

Test Step	36,85 krad	24 hours	192 hours
Serial #			
1 Ref.	2,334E -10	2,142E -10	2,287E -10
2	2,383E -10	1,838E -10	2,136E -10
3	2,445E -10	1,808E -10	2,630E -10
4	2,463E -10	2,167E -10	2,937E -10
5	2,530E -10	1,859E -10	2,033E -10
6	2,514E -10	2,396E -10	2,009E -10
Statistics			
Min	2,383E -10	1,808E -10	2,009E -10
Max	2,530E -10	2,396E -10	2,937E -10
Mean	2,467E -10	2,014E -10	2,349E -10
Sigma	5,853E -12	2,583E -11	4,141E -11

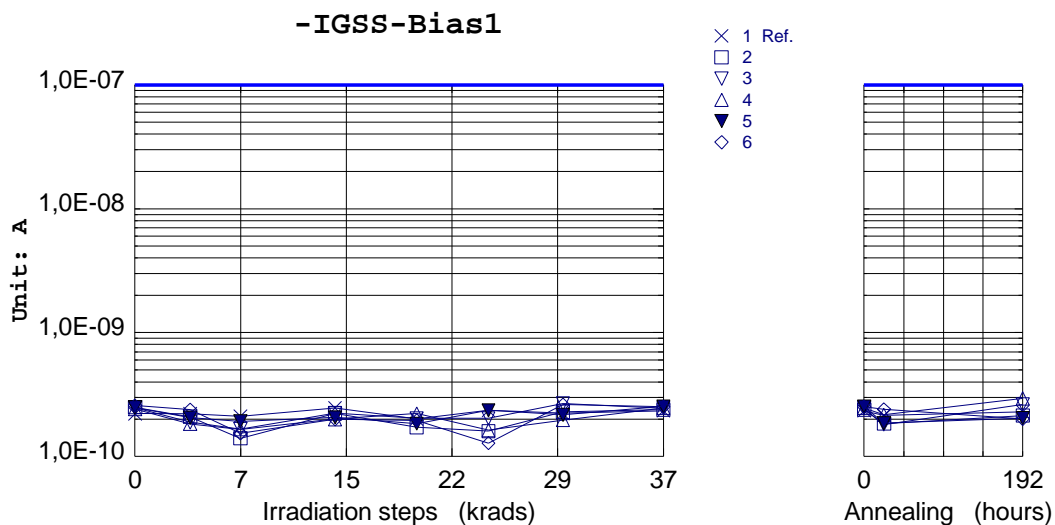

<b>HIREX Engineering</b>	<b>Total Dose Test Report</b>			Réf. : HRX/99.4567 Issue : 01
Part Type :	BUZ341	Manufacturer :	Siemens	

**Parameter: Negative Gate source leakage current: -IGSS-Bias2 VGS=-20V, VDS=0V**

Unit= A

Spec limit max: 100E-9

Spec limits are represented in bold lines on the graphic.

Test Step	Initial	3,85 krad	7,35 krad	13,95 krad	19,65 krad	24,65 krad	29,85 krad
Serial #							
1 Ref.	2,214E -10	2,211E -10	2,109E -10	2,458E -10	2,009E -10	2,355E -10	2,226E -10
7	1,885E -10	2,154E -10	1,779E -10	2,077E -10	1,807E -10	2,189E -10	1,965E -10
8	2,601E -10	2,007E -10	1,824E -10	1,791E -10	2,355E -10	1,891E -10	2,173E -10
9	2,224E -10	1,679E -10	1,389E -10	2,308E -10	1,896E -10	2,007E -10	2,000E -10
10	2,233E -10	1,981E -10	1,960E -10	1,702E -10	2,163E -10	2,236E -10	1,818E -10
11	2,325E -10	1,371E -10	1,951E -10	2,423E -10	2,326E -10	2,129E -10	2,020E -10
Statistics							
Min	1,885E -10	1,371E -10	1,389E -10	1,702E -10	1,807E -10	1,891E -10	1,818E -10
Max	2,601E -10	2,154E -10	1,960E -10	2,423E -10	2,355E -10	2,236E -10	2,173E -10
Mean	2,253E -10	1,839E -10	1,780E -10	2,060E -10	2,109E -10	2,091E -10	1,995E -10
Sigma	2,563E -11	3,133E -11	2,324E -11	3,139E -11	2,484E -11	1,406E -11	1,271E -11

Test Step	36,85 krad	24 hours	192 hours
Serial #			
1 Ref.	2,334E -10	2,142E -10	2,287E -10
7	2,727E -10	2,278E -10	2,307E -10
8	2,690E -10	2,393E -10	2,209E -10
9	2,693E -10	2,224E -10	2,566E -10
10	2,686E -10	2,559E -10	2,535E -10
11	2,676E -10	2,101E -10	1,822E -10
Statistics			
Min	2,676E -10	2,101E -10	1,822E -10
Max	2,727E -10	2,559E -10	2,566E -10
Mean	2,694E -10	2,311E -10	2,288E -10
Sigma	1,935E -12	1,740E -11	3,007E -11

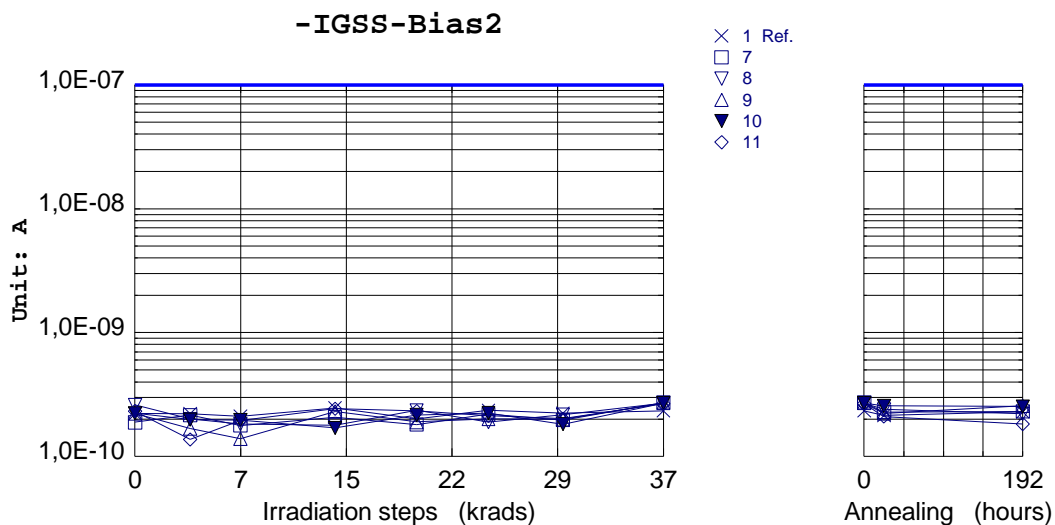



<b>HIREX Engineering</b>	<b>Total Dose Test Report</b>			Réf. : HRX/99.4567 Issue : 01
Part Type :	BUZ341	Manufacturer :	Siemens	

**Parameter: Drain current: IDSS-Bias1 VGS=0V, VDS=200V**

Unit= A

Spec limit max: 1E-6

Spec limits are represented in bold lines on the graphic.

Test Step	Initial	3,85 krad	7,35 krad	13,95 krad	19,65 krad	24,65 krad	29,85 krad
Serial #							
1 Ref.	1,627E -09	2,119E -09	1,925E -09	1,642E -09	1,461E -09	1,903E -09	1,713E -09
2	1,896E -09	8,026E -09	1,533E -08	2,754E -08	4,495E -08	5,179E -08	6,781E -08
3	1,817E -09	6,452E -09	1,313E -08	2,583E -08	4,483E -08	4,887E -08	6,069E -08
4	1,670E -09	7,175E -09	1,407E -08	2,754E -08	4,670E -08	5,453E -08	6,317E -08
5	2,039E -09	7,003E -09	1,361E -08	2,824E -08	5,218E -08	1,091E -07	8,114E -08
6	1,616E -09	6,419E -09	1,356E -08	2,840E -08	4,972E -08	5,942E -08	7,731E -08
Statistics							
Min	1,616E -09	6,419E -09	1,313E -08	2,583E -08	4,483E -08	4,887E -08	6,069E -08
Max	2,039E -09	8,026E -09	1,533E -08	2,840E -08	5,218E -08	1,091E -07	8,114E -08
Mean	1,808E -09	7,015E -09	1,394E -08	2,751E -08	4,768E -08	6,475E -08	1,623E -07
Sigma	1,712E -10	6,560E -10	8,464E -10	1,017E -09	3,199E -09	2,511E -08	3,629E -08

Test Step	36,85 krad	24 hours	192 hours
Serial #			
1 Ref.	1,795E -09	1,482E -09	1,499E -09
2	9,828E -08	9,057E -08	3,768E -08
3	7,645E -08	8,817E -08	3,625E -08
4	7,412E -08	8,738E -08	3,642E -08
5	1,413E -07	1,028E -07	4,178E -08
6	8,540E -08	9,499E -08	3,654E -08
Statistics			
Min	7,412E -08	8,738E -08	3,625E -08
Max	1,413E -07	1,028E -07	4,178E -08
Mean	9,510E -08	9,278E -08	3,773E -08
Sigma	2,749E -08	6,336E -09	2,331E -09

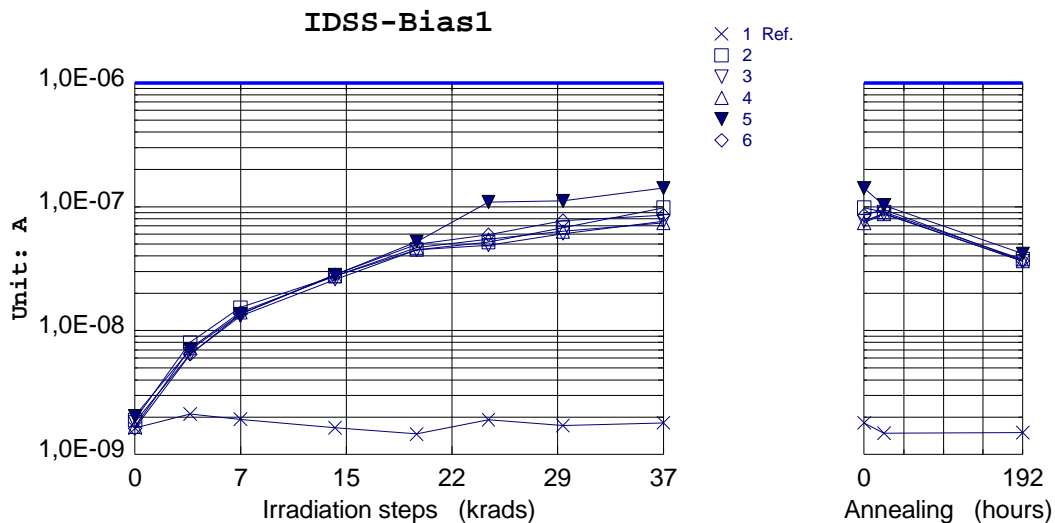

<b>HIREX Engineering</b>	<b>Total Dose Test Report</b>			Réf. : HRX/99.4567 Issue : 01
Part Type :	BUZ341	Manufacturer :	Siemens	

Parameter: Drain current: IDSS-Bias2 VGS=0V, VDS=200V

Unit= A

Spec limit max: 1E-6

Spec limits are represented in bold lines on the graphic.

Test Step	Initial	3,85 krad	7,35 krad	13,95 krad	19,65 krad	24,65 krad	29,85 krad
Serial #							
1 Ref.	1,627E -09	2,119E -09	1,925E -09	1,642E -09	1,461E -09	1,903E -09	1,713E -09
7	1,884E -09	3,861E -08	1,000E -03	4,998E -02	4,999E -02	4,998E -02	4,998E -02
8	1,474E -09	1,704E -08	9,998E -04	4,996E -02	4,997E -02	4,998E -02	4,999E -02
9	2,252E -09	1,001E -03	9,999E -04	4,998E -02	4,998E -02	4,998E -02	4,998E -02
10	1,442E -09	9,997E -04	9,997E -04	4,998E -02	4,998E -02	4,999E -02	4,998E -02
11	1,510E -09	9,985E -04	1,001E -03	4,998E -02	4,998E -02	4,999E -02	4,998E -02
Statistics							
Min	1,442E -09	1,704E -08	9,997E -04	4,996E -02	4,997E -02	4,998E -02	4,998E -02
Max	2,252E -09	1,001E -03	1,001E -03	4,998E -02	4,999E -02	4,999E -02	4,999E -02
Mean	1,712E -09	5,998E -04	1,000E -03	4,998E -02	4,998E -02	4,999E -02	4,998E -02
Sigma	3,503E -10	5,475E -04	3,627E -07	9,177E -06	6,325E -06	2,828E -06	4,562E -06

Test Step	36,85 krad	24 hours	192 hours
Serial #			
1 Ref.	1,795E -09	1,482E -09	1,499E -09
7	4,998E -02	4,999E -02	5,001E -02
8	4,999E -02	5,000E -02	5,007E -02
9	4,998E -02	4,999E -02	5,001E -02
10	4,999E -02	4,999E -02	5,001E -02
11	4,998E -02	4,999E -02	5,001E -02
Statistics			
Min	4,998E -02	4,999E -02	5,001E -02
Max	4,999E -02	5,000E -02	5,007E -02
Mean	4,998E -02	4,999E -02	5,002E -02
Sigma	6,542E -06	3,347E -06	2,691E -05

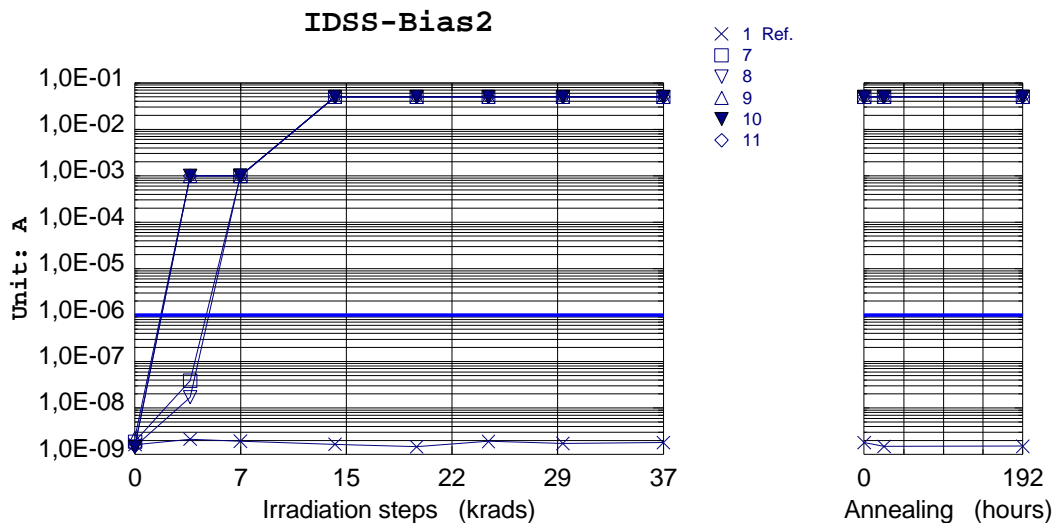

<b>HIREX Engineering</b>	<b>Total Dose Test Report</b>			Réf. : HRX/99.4567 Issue : 01
Part Type :	BUZ341	Manufacturer :	Siemens	

Parameter: Static drain to source on-state resistance: RDSON-Bias1

VGS=10V, ID=21A

Unit= Ohm

Spec limit max: 0.07

Spec limits are represented in bold lines on the graphic.

Test Step	Initial	3,85 krad	7,35 krad	13,95 krad	19,65 krad	24,65 krad	29,85 krad
Serial #							
1 Ref.	5,390E -02	5,324E -02	5,267E -02	5,461E -02	5,324E -02	5,343E -02	5,305E -02
2	5,381E -02	5,381E -02	5,390E -02	5,381E -02	5,448E -02	5,352E -02	5,317E -02
3	5,495E -02	5,495E -02	5,505E -02	5,467E -02	5,562E -02	5,476E -02	5,400E -02
4	5,489E -02	5,476E -02	5,486E -02	5,476E -02	5,562E -02	5,467E -02	5,400E -02
5	5,229E -02	5,200E -02	5,219E -02	5,229E -02	5,286E -02	5,190E -02	5,124E -02
6	5,390E -02	5,343E -02	5,371E -02	5,352E -02	5,438E -02	5,343E -02	5,286E -02
Statistics							
Min	5,229E -02	5,200E -02	5,219E -02	5,229E -02	5,286E -02	5,190E -02	5,124E -02
Max	5,495E -02	5,495E -02	5,505E -02	5,476E -02	5,562E -02	5,476E -02	5,400E -02
Mean	5,397E -02	5,379E -02	5,394E -02	5,381E -02	5,459E -02	5,366E -02	5,305E -02
Sigma	1,082E -03	1,186E -03	1,138E -03	1,006E -03	1,138E -03	1,160E -03	1,134E -03

Test Step	36,85 krad	24 hours	192 hours
Serial #			
1 Ref.	5,333E -02	5,410E -02	5,305E -02
2	5,305E -02	5,381E -02	5,343E -02
3	5,400E -02	5,514E -02	5,476E -02
4	5,390E -02	5,499E -02	5,476E -02
5	5,133E -02	5,229E -02	5,212E -02
6	5,295E -02	5,381E -02	5,333E -02
Statistics			
Min	5,133E -02	5,229E -02	5,212E -02
Max	5,400E -02	5,514E -02	5,476E -02
Mean	5,305E -02	5,401E -02	5,368E -02
Sigma	1,071E -03	1,150E -03	1,112E -03

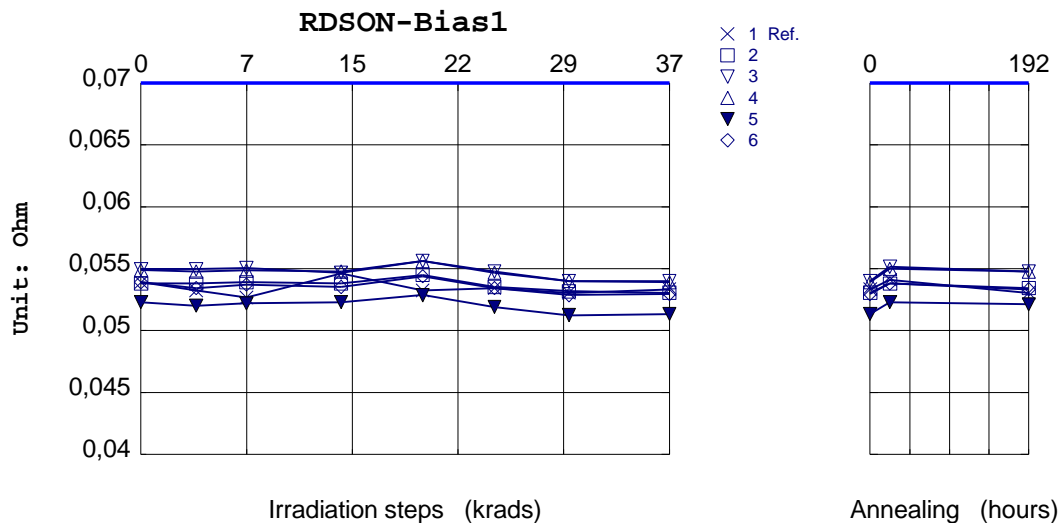

<b>HIREX Engineering</b>	<b>Total Dose Test Report</b>			Réf. : HRX/99.4567 Issue : 01
Part Type :	BUZ341	Manufacturer :	Siemens	

Parameter: Static drain to source on-state resistance: RDSON-Bias2

VGS=10V, ID=21A

Unit= Ohm

Spec limit max: 0.07

Spec limits are represented in bold lines on the graphic.

Test Step	Initial	3,85 krad	7,35 krad	13,95 krad	19,65 krad	24,65 krad	29,85 krad
Serial #							
1 Ref.	5,390E -02	5,324E -02	5,267E -02	5,461E -02	5,324E -02	5,343E -02	5,305E -02
7	5,381E -02	5,371E -02	5,419E -02	5,419E -02	5,524E -02	5,448E -02	5,419E -02
8	5,562E -02	5,585E -02	5,600E -02	5,610E -02	5,733E -02	5,648E -02	5,600E -02
9	5,200E -02	5,286E -02	5,248E -02	5,248E -02	5,343E -02	5,286E -02	5,248E -02
10	5,562E -02	5,552E -02	5,571E -02	5,590E -02	5,724E -02	5,657E -02	5,610E -02
11	5,400E -02	5,381E -02	5,419E -02	5,429E -02	5,562E -02	5,486E -02	5,448E -02
Statistics							
Min	5,200E -02	5,286E -02	5,248E -02	5,248E -02	5,343E -02	5,286E -02	5,248E -02
Max	5,562E -02	5,585E -02	5,600E -02	5,610E -02	5,733E -02	5,657E -02	5,610E -02
Mean	5,421E -02	5,435E -02	5,451E -02	5,459E -02	5,577E -02	5,505E -02	5,465E -02
Sigma	1,505E -03	1,279E -03	1,415E -03	1,476E -03	1,611E -03	1,543E -03	1,490E -03

Test Step	36,85 krad	24 hours	192 hours
Serial #			
1 Ref.	5,333E -02	5,410E -02	5,305E -02
7	5,438E -02	5,552E -02	6,390E -02
8	5,638E -02	5,762E -02	6,724E -02
9	5,276E -02	5,381E -02	6,410E -02
10	5,648E -02	5,762E -02	6,933E -02
11	5,486E -02	5,590E -02	6,733E -02
Statistics			
Min	5,276E -02	5,381E -02	6,390E -02
Max	5,648E -02	5,762E -02	6,933E -02
Mean	5,497E -02	5,610E -02	6,638E -02
Sigma	1,541E -03	1,599E -03	2,330E -03

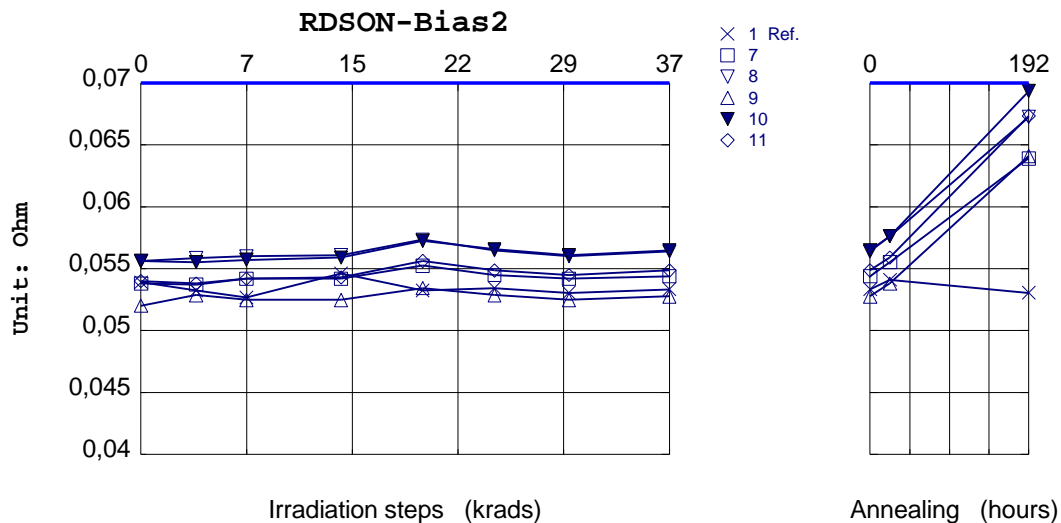

<b>HIREX Engineering</b>	<b>Total Dose Test Report</b>		Réf. : HRX/99.4567 Issue : 01
Part Type :	BUZ341	Manufacturer :	Siemens

## 8 Conclusion

A total dose radiation verification test has been performed on BUZ341 N-Channel Power Mosfet from SIEMENS up to 36.85 Krad(Si) accumulated dose.

BVDSS under Bias 2 conditions is marginally out of specification at 3.85 Krad(Si), continues to degrade subsequently, and does not completely recover during final steps.

BVDSS under Bias 1 conditions is out of specification at 24.65 Krad(Si) for one sample. Other samples are beyond specification limit at 29,85 Krad(Si), and a recovery is observed after 168 hours annealing.

Threshold voltage is out of specification at 13.95 Krad(Si) under Bias 2 conditions. A recovery is observed after 168 hours annealing step.

Threshold voltage is out of specification at 29.85 Krad(Si) under Bias 1 conditions, but a complete recovery is observed after 168 hours annealing step.

IDSS, under Bias 2 conditions, increases significantly at low dose (3.85 Krad(Si)), continues to degrade up to the compliance value. No recovery is noted during annealing.

A rebound effect has been observed on  $R_{ds_{on}}$  under Bias 2 conditions, during the last annealing step. This parameter reaching the limit of its specification.

<b>HIREX Engineering</b>	<b>Total Dose Test Report</b>		Réf. : HRX/99.4567 Issue : 01
Part Type :	BUZ341	Manufacturer :	Siemens

**ANNEX 1 : BUZ341 DATA SHEET**

### SIPMOS® Power Transistor

- N channel
- Enhancement mode
- Avalanche-rated

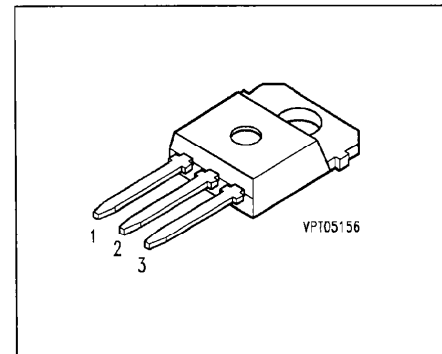

Pin 1	Pin 2	Pin 3
G	D	S

Type	$V_{DS}$	$I_D$	$R_{DS(on)}$	Package	Ordering Code
BUZ 341	200 V	33 A	0.07 $\Omega$	TO-218 AA	C67078-S3128-A2

#### Maximum Ratings

Parameter	Symbol	Values	Unit
Continuous drain current $T_C = 28\text{ }^\circ\text{C}$	$I_D$	33	A
Pulsed drain current $T_C = 25\text{ }^\circ\text{C}$	$I_{Dpuls}$	132	
Avalanche current, limited by $T_{jmax}$	$I_{AR}$	33	
Avalanche energy, periodic limited by $T_{jmax}$	$E_{AR}$	16	mJ
Avalanche energy, single pulse $I_D = 33\text{ A}$ , $V_{DD} = 50\text{ V}$ , $R_{GS} = 25\text{ }^\circ\Omega$ $L = 1.09\text{ mH}$ , $T_j = 25\text{ }^\circ\text{C}$	$E_{AS}$	790	
Gate source voltage	$V_{GS}$	$\pm 20$	V
Power dissipation $T_C = 25\text{ }^\circ\text{C}$	$P_{tot}$	170	W
Operating temperature	$T_j$	-55 ... + 150	$^\circ\text{C}$
Storage temperature	$T_{stg}$	-55 ... + 150	
Thermal resistance, chip case	$R_{thJC}$	$\leq 0.74$	K/W
Thermal resistance, chip to ambient	$R_{thJA}$	75	
DIN humidity category, DIN 40 040		E	
IEC climatic category, DIN IEC 68-1		55 / 150 / 56	

**Electrical Characteristics**, at  $T_j = 25^\circ\text{C}$ , unless otherwise specified

Parameter	Symbol	Values			Unit
		min.	typ.	max.	
<b>Static Characteristics</b>					
Drain- source breakdown voltage $V_{GS} = 0\text{ V}$ , $I_D = 0.25\text{ mA}$ , $T_j = 25\text{ }^\circ\text{C}$	$V_{(BR)DSS}$	200	-	-	V
Gate threshold voltage $V_{GS} = V_{DS}$ , $I_D = 1\text{ mA}$	$V_{GS(th)}$	2.1	3	4	
Zero gate voltage drain current $V_{DS} = 200\text{ V}$ , $V_{GS} = 0\text{ V}$ , $T_j = 25\text{ }^\circ\text{C}$ $V_{DS} = 200\text{ V}$ , $V_{GS} = 0\text{ V}$ , $T_j = 125\text{ }^\circ\text{C}$	$I_{DSS}$	-	0.1 10	1 100	$\mu\text{A}$
Gate-source leakage current $V_{GS} = 20\text{ V}$ , $V_{DS} = 0\text{ V}$	$I_{GSS}$	-	10	100	nA
Drain-Source on-resistance $V_{GS} = 10\text{ V}$ , $I_D = 21\text{ A}$	$R_{DS(on)}$	-	0.06	0.07	$\Omega$



**Electrical Characteristics**, at  $T_j = 25^\circ\text{C}$ , unless otherwise specified

Parameter	Symbol	Values			Unit
		min.	typ.	max.	
<b>Dynamic Characteristics</b>					
Transconductance $V_{DS} \geq 2 \cdot I_D \cdot R_{DS(on)max}$ , $I_D = 21 \text{ A}$	$g_{fs}$	15	23	-	S
Input capacitance $V_{GS} = 0 \text{ V}$ , $V_{DS} = 25 \text{ V}$ , $f = 1 \text{ MHz}$	$C_{iss}$	-	2600	3900	pF
Output capacitance $V_{GS} = 0 \text{ V}$ , $V_{DS} = 25 \text{ V}$ , $f = 1 \text{ MHz}$	$C_{oss}$	-	500	750	
Reverse transfer capacitance $V_{GS} = 0 \text{ V}$ , $V_{DS} = 25 \text{ V}$ , $f = 1 \text{ MHz}$	$C_{rss}$	-	230	350	
Turn-on delay time $V_{DD} = 30 \text{ V}$ , $V_{GS} = 10 \text{ V}$ , $I_D = 3 \text{ A}$ $R_{GS} = 50 \Omega$	$t_{d(on)}$	-	40	60	ns
Rise time $V_{DD} = 30 \text{ V}$ , $V_{GS} = 10 \text{ V}$ , $I_D = 3 \text{ A}$ $R_{GS} = 50 \Omega$	$t_r$	-	110	170	
Turn-off delay time $V_{DD} = 30 \text{ V}$ , $V_{GS} = 10 \text{ V}$ , $I_D = 3 \text{ A}$ $R_{GS} = 50 \Omega$	$t_{d(off)}$	-	450	680	
Fall time $V_{DD} = 30 \text{ V}$ , $V_{GS} = 10 \text{ V}$ , $I_D = 3 \text{ A}$ $R_{GS} = 50 \Omega$	$t_f$	-	160	240	

**Electrical Characteristics, at  $T_j = 25^\circ\text{C}$ , unless otherwise specified**

Parameter	Symbol	Values			Unit
		min.	typ.	max.	
<b>Reverse Diode</b>					
Inverse diode continuous forward current $T_C = 25^\circ\text{C}$	$I_S$	-	-	33	A
Inverse diode direct current,pulsed $T_C = 25^\circ\text{C}$	$I_{SM}$	-	-	132	
Inverse diode forward voltage $V_{GS} = 0\text{ V}, I_F = 66\text{ A}$	$V_{SD}$	-	1.3	1.6	V
Reverse recovery time $V_R = 100\text{ V}, I_F = I_S, di_F/dt = 100\text{ A}/\mu\text{s}$	$t_{rr}$	-	230	-	ns
Reverse recovery charge $V_R = 100\text{ V}, I_F = I_S, di_F/dt = 100\text{ A}/\mu\text{s}$	$Q_{rr}$	-	1.8	-	$\mu\text{C}$

### Power dissipation

$$P_{\text{tot}} = f(T_C)$$

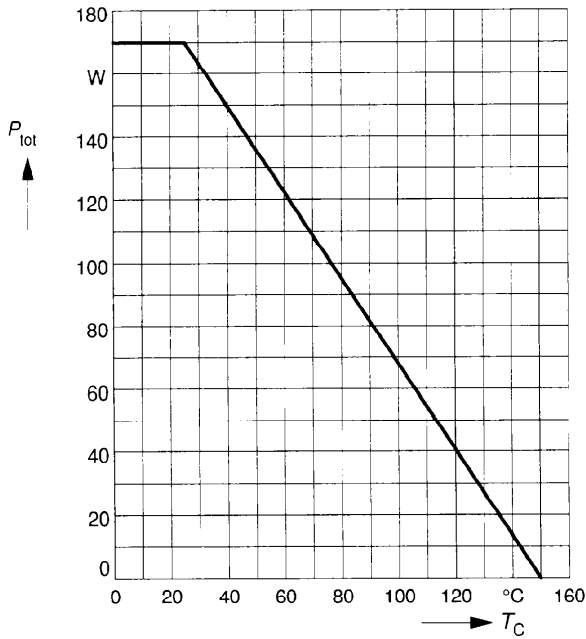

### Drain current

$$I_D = f(T_C)$$

parameter:  $V_{GS} \geq 10 \text{ V}$

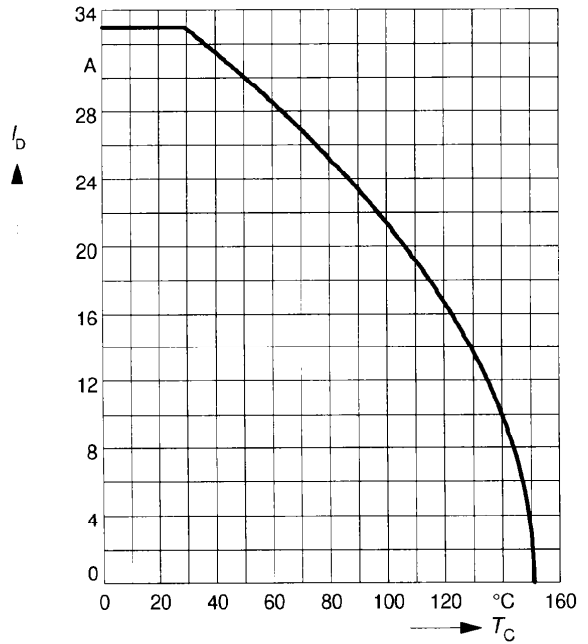

### Safe operating area

$$I_D = f(V_{DS})$$

parameter:  $D = 0.01, T_C = 25^\circ\text{C}$

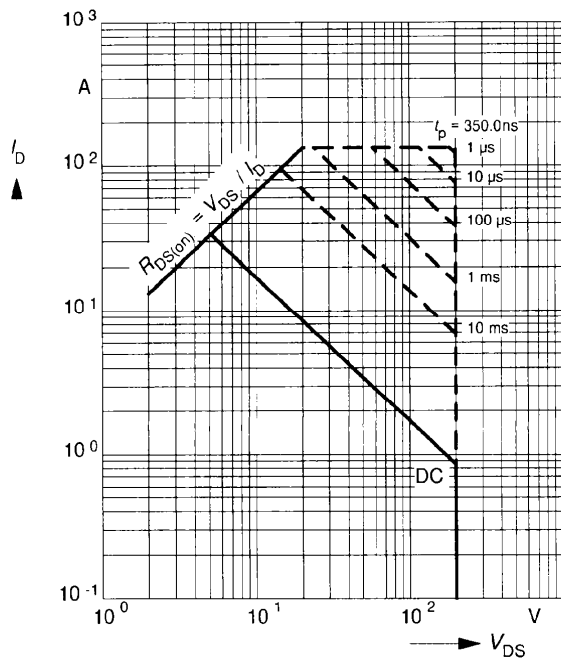

### Transient thermal impedance

$$Z_{\text{thJC}} = f(t_p)$$

parameter:  $D = t_p / T$

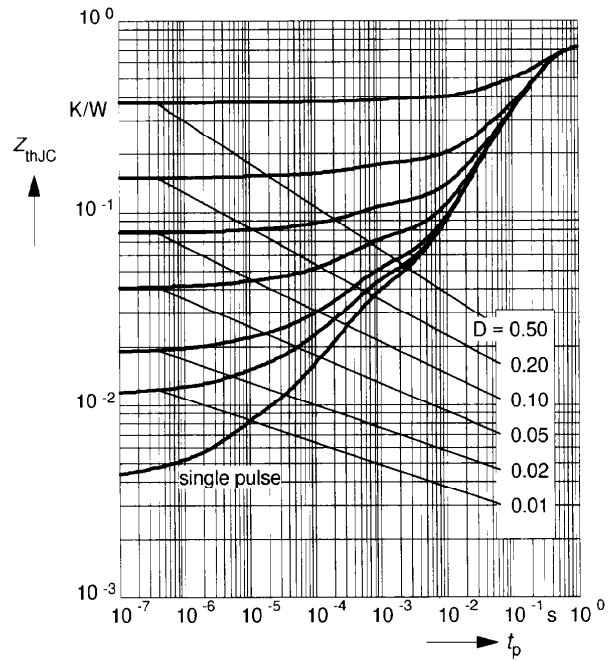

### Typ. output characteristics

$I_D = f(V_{DS})$   
parameter:  $t_p = 80 \mu s$

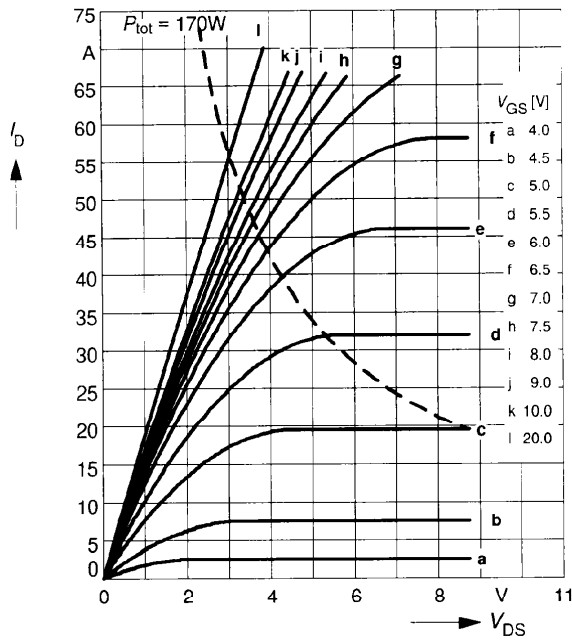

### Typ. drain-source on-resistance

$R_{DS(on)} = f(I_D)$   
parameter:  $V_{GS}$

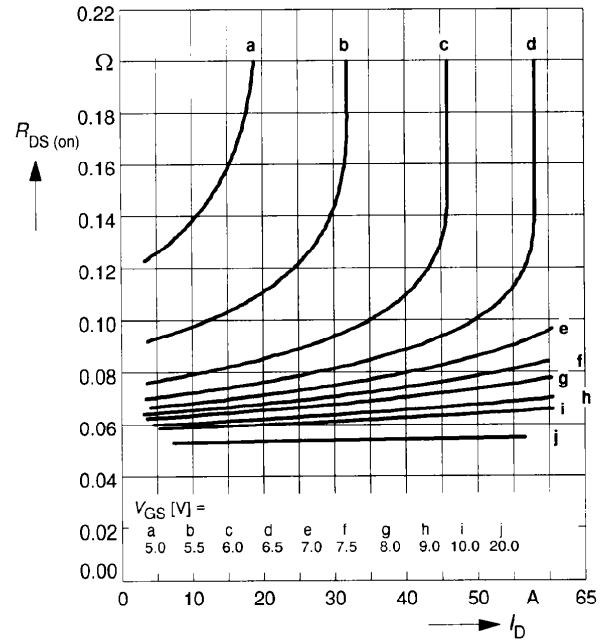

### Typ. transfer characteristics $I_D = f(V_{GS})$

parameter:  $t_p = 80 \mu s$   
 $V_{DS} \geq 2 \times I_D \times R_{DS(on)max}$

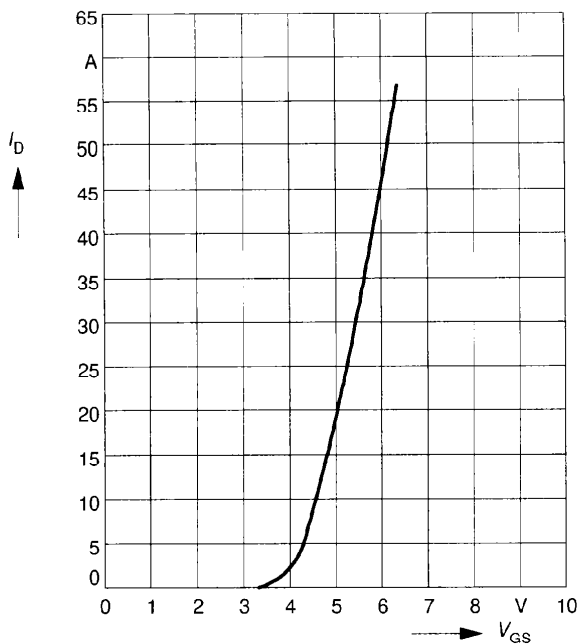

### Typ. forward transconductance $g_{fs} = f(I_D)$

parameter:  $t_p = 80 \mu s$ ,  
 $V_{DS} \geq 2 \times I_D \times R_{DS(on)max}$

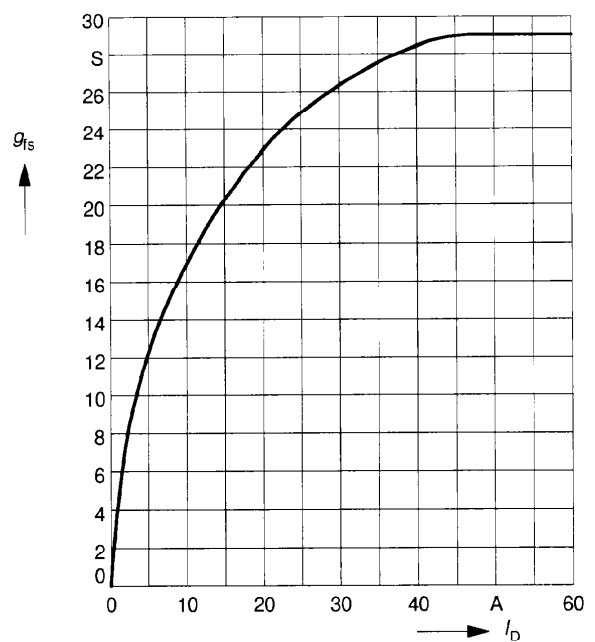

### Drain-source on-resistance

$$R_{DS(on)} = f(T_j)$$

parameter:  $I_D = 21\text{ A}$ ,  $V_{GS} = 10\text{ V}$

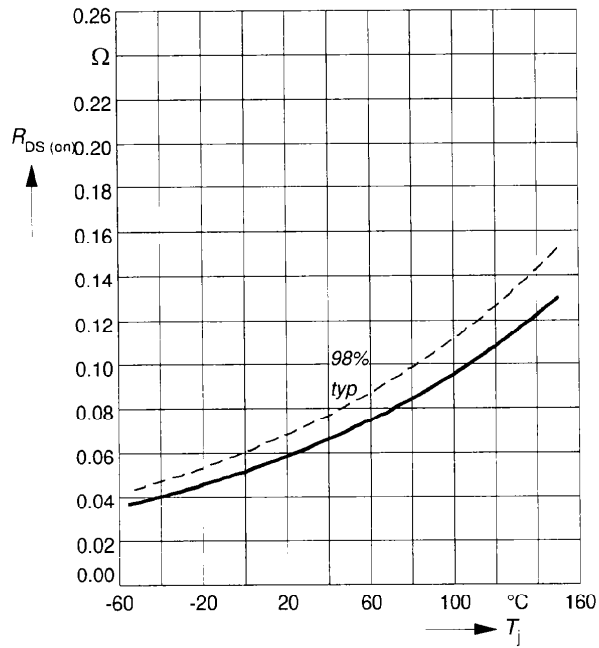

### Gate threshold voltage

$$V_{GS(th)} = f(T_j)$$

parameter:  $V_{GS} = V_{DS}$ ,  $I_D = 1\text{ mA}$

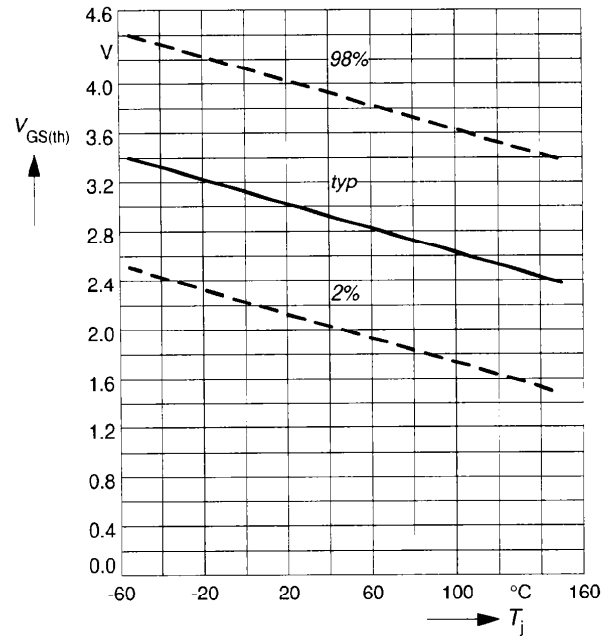

### Typ. capacitances

$$C = f(V_{DS})$$

parameter:  $V_{GS} = 0\text{ V}$ ,  $f = 1\text{ MHz}$

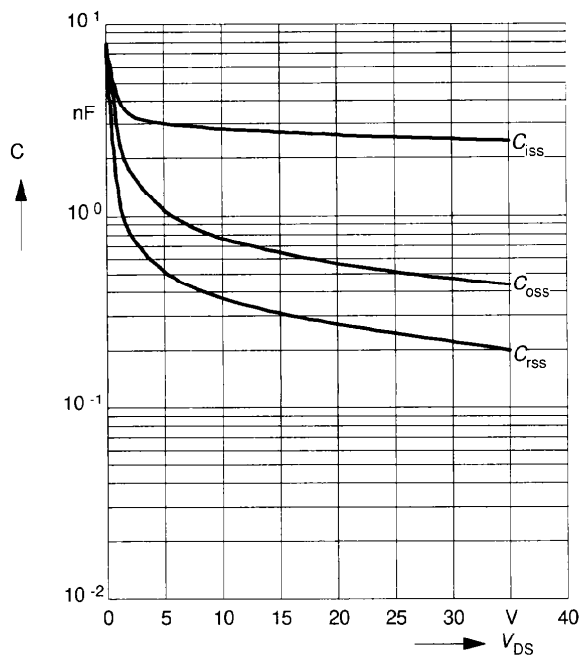

### Forward characteristics of reverse diode

$$I_F = f(V_{SD})$$

parameter:  $T_j$ ,  $t_p = 80\text{ }\mu\text{s}$

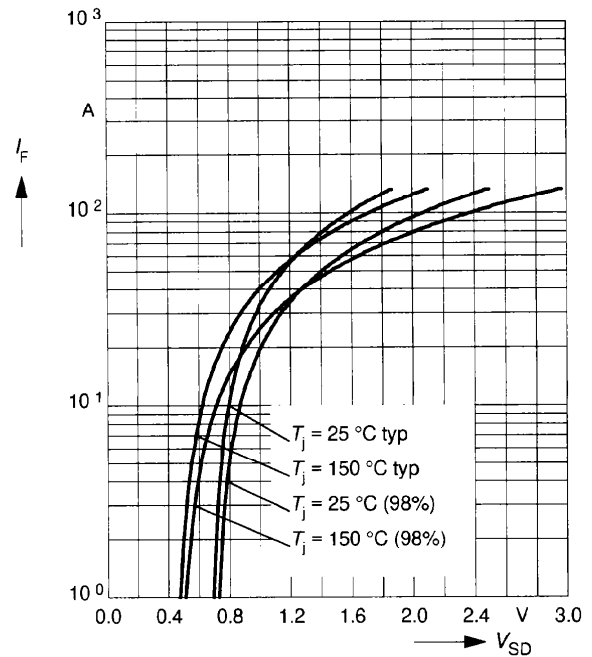

### Avalanche energy $E_{AS} = f(T_j)$

parameter:  $I_D = 33 \text{ A}$ ,  $V_{DD} = 50 \text{ V}$

$R_{GS} = 25 \text{ } \Omega$ ,  $L = 1.09 \text{ mH}$

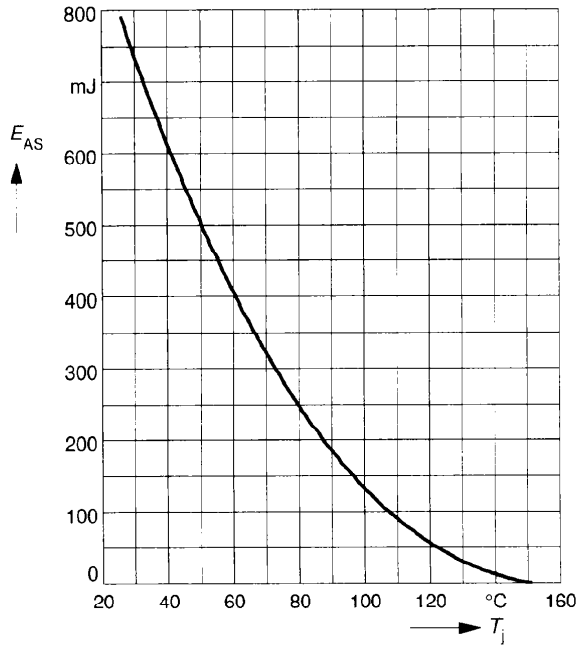

### Typ. gate charge $V_{GS} = f(Q_{Gate})$

parameter:  $I_{D \text{ puls}} = 50 \text{ A}$

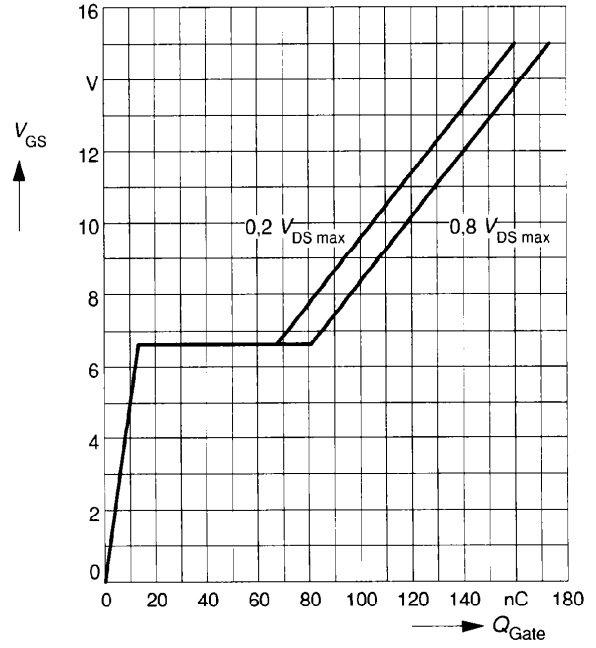

### Drain-source breakdown voltage $V_{(BR)DSS} = f(T_j)$

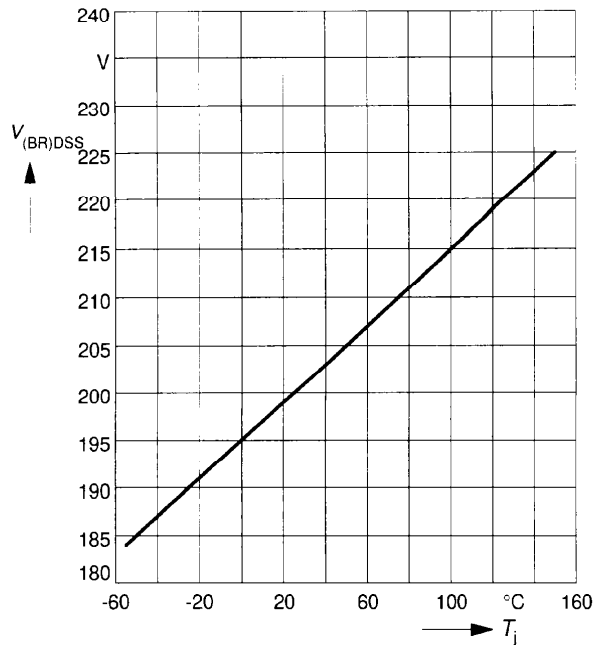

## Package Outlines

TO-218 AA

Dimension in mm

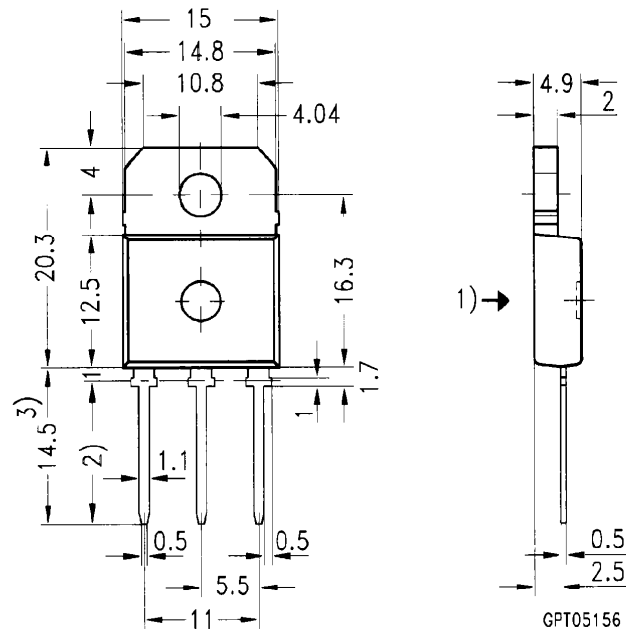

- 1) punch direction, burr max. 0.04
- 2) dip tinning
- 3) max. 15.5 by dip tinning press burr max. 0.05