



# SINGLE EVENT EFFECTS RADIATION TEST REPORT

**Part Type : SP200V**

**Package : TO-3**

**N-Channel Power MOSFET**

**SGS Thomson**

**Report Reference : ESA\_QCA990911S\_C**

**Issue : 01**

**Date : July 2<sup>nd</sup> 1999**

ESA Contract No 13413/98/NL/MV dated 25/01/99

European Space Agency Contract Report

The work described in this report was done under ESA contract.  
Responsibility for the contents resides in the author or organization that prepared it

ESTEC Technical Officer : R. Harboe Sorensen

<b>Hirex reference :</b>	HRX/99.4603	Issue : 01	Date :	July 2, 1999
<b>Prepared by :</b>	H. CONSTANS/FX GUERRE		Date :	
<b>Approved by :</b>	F.X GUERRE		Date :	

	<b>SEE TEST REPORT</b> HRX/99.4603		Rev. -	PAGE 2 ISSUE 1 July 2, 1999
	Part Type :	SP200V	Manufacturer	SGS Thomson

**TABLE OF CHANGES**

Issue 1      July 2, 1999  
 Original Issue

	<b>SEE TEST REPORT</b> HRX/99.4603		Rev. -	<b>PAGE 3</b> ISSUE 1 July 2, 1999
	Part Type :	SP200V	Manufacturer	SGS Thomson

**TABLE OF CONTENTS**

<b>I.</b>	<b>ABSTRACT</b>	<b>4</b>
<b>II.</b>	<b>INTRODUCTION</b>	<b>5</b>
<b>III.</b>	<b>DOCUMENTS</b>	<b>5</b>
III.1	APPLICABLE DOCUMENTS	5
III.2	REFERENCE DOCUMENTS	5
<b>IV.</b>	<b>DEVICE INFORMATION</b>	<b>6</b>
IV.1	DEVICE DESCRIPTION	6
IV.2	PROCUREMENT OF TEST SAMPLES	6
IV.3	PREPARATION OF SAMPLES	6
IV.4	SAMPLES CHECK OUT	6
IV.5	DEVICE MARKING	6
<b>V.</b>	<b>DEVICE TEST DEFINITION</b>	<b>7</b>
V.1	PREPARATION OF TEST HARDWARE AND PROGRAM	7
V.2	GENERIC TEST SET-UP	7
V.2.1	Mother board description (Ref. IL140A)	7
V.2.2	DUT Test board description	10
V.3	TEST CONFIGURATION	10
V.3.1	Single Event burnout (SEB)	10
V.3.2	Single Event Gate Rupture (SEGR)	11
<b>VI.</b>	<b>TEST FACILITIES</b>	<b>12</b>
VI.1	HEAVY IONS	12
VI.1.1	Beam Source	12
VI.1.2	Beam Set-up	12
<b>VII.</b>	<b>HEAVY IONS RESULTS</b>	<b>13</b>
VII.1	SP200V TEST RESULTS	13
VII.2	TYPICAL SEB WAVEFORM	13
<b>VIII.</b>	<b>CONCLUSION</b>	<b>14</b>

**FIGURES**

Figure 1 – Device marking	6
Figure 2 - Generic Test Set-up	8
Figure 3 – Functional diagram for SEE Test	9
Figure 4 – Equivalent circuit for SEB including the parasitic capacitor of the MOSFET.	10
Figure 5 – Example of non destructive SEBs observed on a 100V transistor at 60V and 70V Vds ratings	13

**TABLES**

Table 1 – Test circuit resistor values	10
Table 2 – Heavy Ion Test results on SP200V N-Channel Power MOSFET from SGS Thomson Semiconductor :	15

	<b>SEE TEST REPORT</b> HRX/99.4603		Rev. -	<b>PAGE 4</b> ISSUE 1 July 2, 1999
	Part Type :	SP200V	Manufacturer	SGS Thomson

I. **ABSTRACT**

Under ESA/ESTEC contract n° 13413/98/NL/MV covering "Radiation Evaluation of Power MOSFET Devices from Different European Manufacturers", a large number of commercial Power MOSFET device types were radiation assessed. Results from these assessments, primarily focused on the radiation sensitivity of the MOSFETs to Total Ionizing Dose (TID) and Single Event Effects (SEE), are reported in individual TID and SEE reports. Below summary table list manufacturer and evaluated types, and give references to the various reports issued.

Manufacturer	Type	TID Report	SEE Report
Philips	PHP50N06T	ESA_QCA990901T_C	ESA_QCA990901S_C
Philips	BUK456-200A	ESA_QCA990902T_C	ESA_QCA990902S_C
Motorola	MTP50N06VL	ESA_QCA990903T_C	
Motorola	MTW32N20E	ESA_QCA990904T_C	
Motorola	MTP50N06V	ESA_QCA990905T_C	
Siemens	BUZ100S	ESA_QCA990906T_C	ESA_QCA990906S_C
Siemens	BUZ100SL	ESA_QCA990907T_C	ESA_QCA990907S_C
Siemens	BUZ341	ESA_QCA990908T_C	ESA_QCA990908S_C
SGS-Thomson	SP60	ESA_QCA990909T_C	ESA_QCA990909S_C
SGS-Thomson	SP100V	ESA_QCA9909010T_C	ESA_QCA9909010S_C
SGS-Thomson	SP200V	ESA_QCA9909011T_C	ESA_QCA9909011S_C
Siemens	SPP1N60S5	ESA_QCA9909012T_C	ESA_QCA9909012S_C
Philips	BUK7508-55	ESA_QCA9909013T_C	ESA_QCA9909013S_C
Harris	HUF75639P3	ESA_QCA9909014T_C	ESA_QCA9909014S_C

	<b>SEE TEST REPORT</b> HRX/99.4603		Rev. -	PAGE 5 ISSUE 1 July 2, 1999
	Part Type :	SP200V	Manufacturer	SGS Thomson

## II. INTRODUCTION

This report presents the results of a heavy ion Single Event Effects (SEEs) test program carried out on SP200V N-Channel Power MOSFET from SGS Thomson Semiconductor. Devices were tested at the European Heavy Ion Irradiation Facility (HIF) at Cyclone, Université Catholique de Louvain, Belgium.

This work was performed for ESA/ESTEC under ESA Contract No 13413/98/NL/MV dated 25/01/99

## III. DOCUMENTS

### III.1 APPLICABLE DOCUMENTS

- AD1. Hirex Engineering proposal ref. HRX/98.3475 Issue 1, "Radiation Evaluation of Power MOS Devices from Different European Manufacturers"
- AD2. ESA memorandum Appendix 1 to ESTEC/Contract No 13413/NL/MV

### III.2 REFERENCE DOCUMENTS

- RD1. Power MOS samples SGS letter ref. BE/PB/98187ce01
- RD2. Single Event Effects Test method and Guidelines ESA/SCC basic specification No 25100
- RD3. The Heavy Ion Irradiation Facility at CYCLONE, UCL document, Centre de Recherches du Cyclotron (IEEE NSREC'96, Workshop Record, Indian Wells, California, 1996)

	<b>SEE TEST REPORT</b> HRX/99.4603		Rev. -	PAGE 6 ISSUE 1 July 2, 1999
	Part Type :	SP200V	Manufacturer	SGS Thomson

#### IV. DEVICE INFORMATION

##### IV.1 DEVICE DESCRIPTION

N-Channel Power MOSFET, 200 Volts, 9 A encapsulated in TO3 package

##### IV.2 PROCUREMENT OF TEST SAMPLES

Delivered by ESA

##### IV.3 PREPARATION OF SAMPLES

Devices have been delidded by Hirex Lab.

##### IV.4 SAMPLES CHECK OUT

A functional test sequence has been performed on delidded samples to check that devices have not been degraded by the delidding operation.

##### IV.5 DEVICE MARKING

Device marking is provided in Figure 1



**Figure 1 – Device marking**

Technology : Strip-based process

Die metallization : Aluminum

Die dimensions (approximately, mm<sup>2</sup>) : 2,6 x 2,4

Further details on die description are provided in "Comparative Description and Analysis of Various Power MOSFETs", ESA document ref. ESA\_QCA9909015\_C (Hirex ref. HRX/99.4775) / ESA Contract No 13413/98/NL/MV dated 25/01/99.

	<b>SEE TEST REPORT</b> HRX/99.4603		Rev. -	PAGE 7 ISSUE 1 July 2, 1999
	Part Type :	SP200V	Manufacturer	SGS Thomson

## V. DEVICE TEST DEFINITION

### V.1 PREPARATION OF TEST HARDWARE AND PROGRAM

Overall device emulation, SEE, data storage and processing were implemented using an in-house test hardware and application specific test boards.

The generic in-house test equipment is driven by a PC computer through a RS232 line. All power supplies and input signals are delivered and monitored by the in-house equipment which also stores in its memory the output data from the device throughout the specific test board.

The application specific test board allowed to interface the standard test hardware with the device under test, in order to correctly emulate the relevant part, to record all the different type of errors during the irradiation and to set output signal for processing and storage by the standard test equipment.

At the end of each test run, data are transferred to the PC computer through the RS232 link for storage on hard disk or floppies.

### V.2 GENERIC TEST SET-UP

Generic device test set-up is presented in Figure 2.

This set-up is constituted of the following units:

- A PC computer (to configure and interface with the test system and store the data),
- An electronic rack with the instrumentation functions provided by a set of electronic modules,
- A mother board under vacuum which allows for the sequential test of up to 10 devices.
- A digital oscilloscope to store analog SEE waveform

SEE Test functional diagram is shown in Figure 3.

#### V.2.1 Mother board description (Ref. IL140A)

The motherboard acts as a standard interface between each DUT test board and the control unit :

For each slot, the following signals can be considered:

- 4 inputs signals
    - Drain Source programmable power supply
    - Gate Source programmable power supply
    - Simulation signal
    - Heater control signal
  - 1 output signal
    - 1 fast analog output signal
- IL140 board has been designed to comply with both PSI and Louvain test facilities .
  - Each device needs a dedicated plug-in test board compatible with IL140 mother board.
  - The number of slots is limited to 10: Up to 10 TO220 DUT test boards can be plugged or 5 TO3 DUT test boards.
  - Operation is multiplexed and only one slot is powered at one time.

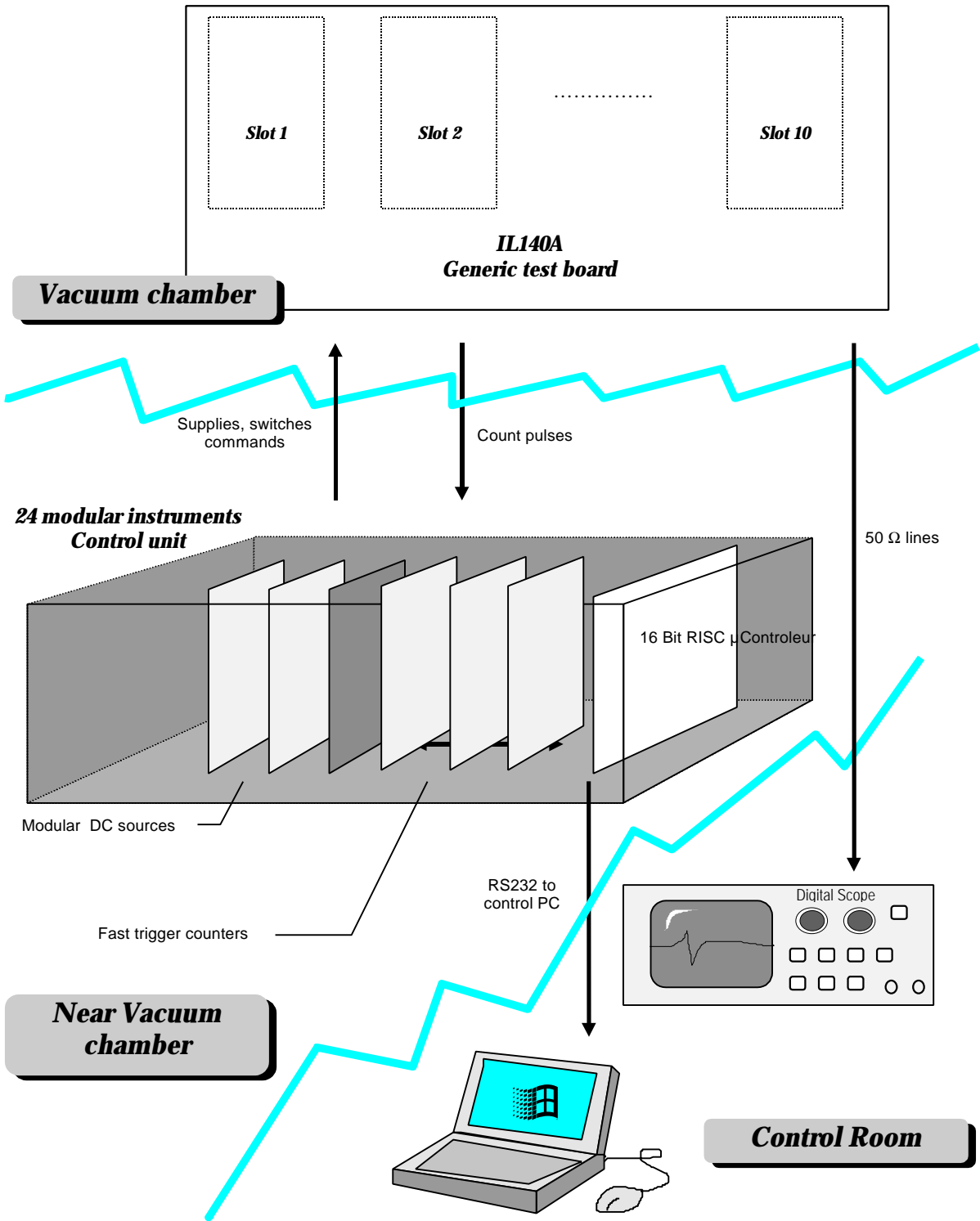

**Figure 2 - Generic Test Set-up**



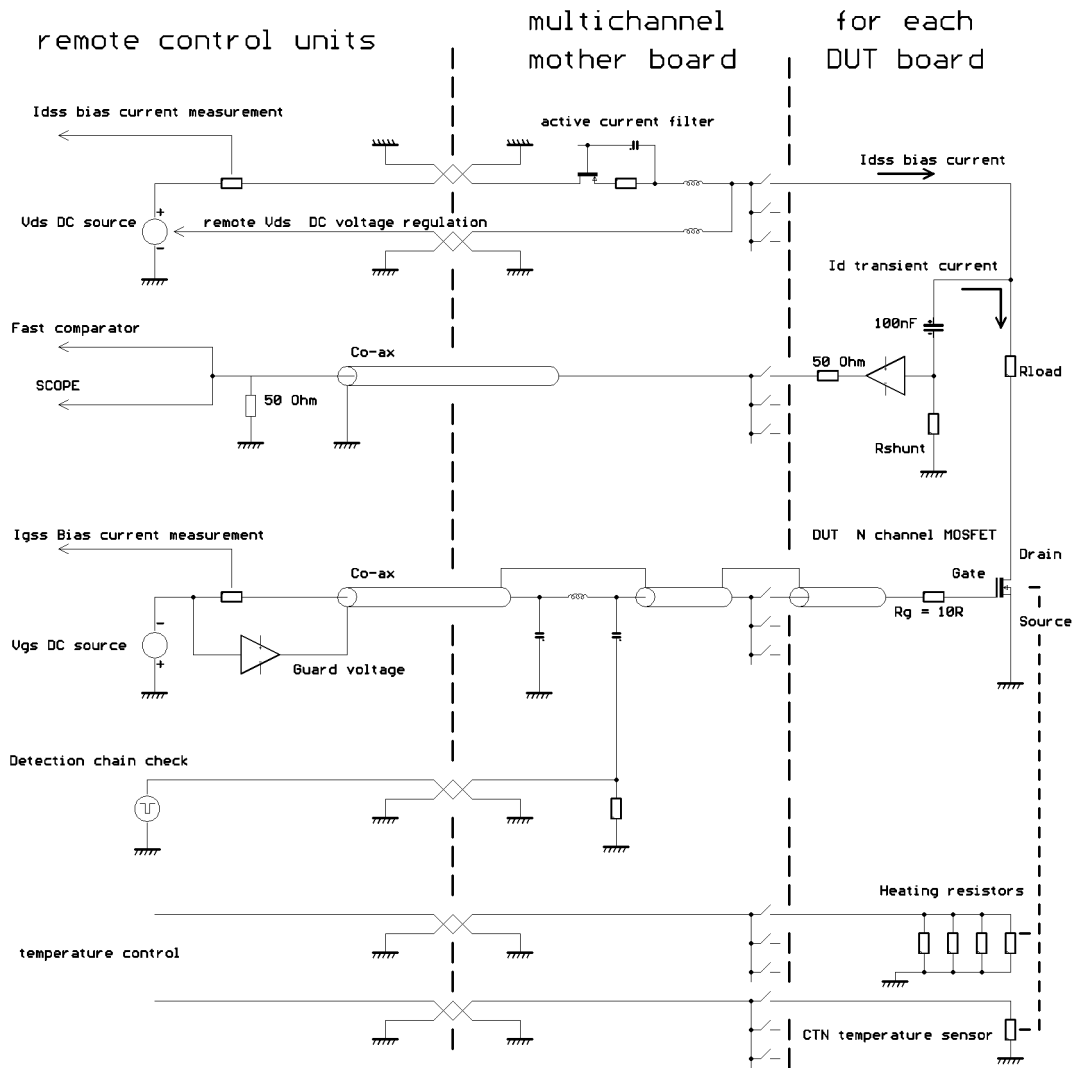

Figure 3 – Functional diagram for SEE Test

V.2.2 DUT Test board description

The device under test is mounted on a specific PCB board which again is connected to the motherboard.

Two different DUT boards have been designed which can be fitted with either a TO2xx plastic package device or with TO3 metal package device.

On each individual DUT board, a limiting current serie resistance and a shunt resistor are mounted for SEB pulse measurement.

To prevent the destructive burn-out of the DUT when the parasitic Bipolar Junction Transistor (BJT) is triggered on by a strike, the DUT Drain is biased with a capacitor and a limiting current resistor mounted on each DUT board. This is to limit the amount of energy available as well as the maximum transient current value.

For testing at elevated temperature, each board is equipped with surface mount heating resistors plus a CTN thermistor for temperature control.

V.3 TEST CONFIGURATION

Test set-up which has been used for the present test report, allows for the detection of both Single Event Burn-out (SEB) and Single Event Gate Rupture (SEGR) effects

V.3.1 Single Event burnout (SEB)

SEB can be observed with the MOSFET in the off mode.

To get non destructive SEBs, selected test principle was to limit as much as possible the energy which could flow into the DUT when the parasitic bipolar transistor enters second breakdown.

To achieve this goal, a resistor Rload (see Figure 3) in serie with the DUT drain limits the current which can flow from the bias circuit (capacitor of 100nF, see Figure 3). In that case the only available energy which can flow into the DUT without any external current limitation is the one stored into the output DUT capacitance  $C_{DS}$ .

The equivalent circuit when an SEB is triggered is shown in Figure 4.

Observation of VDS transients is done at Rshunt which form a resistor divider with Rload.

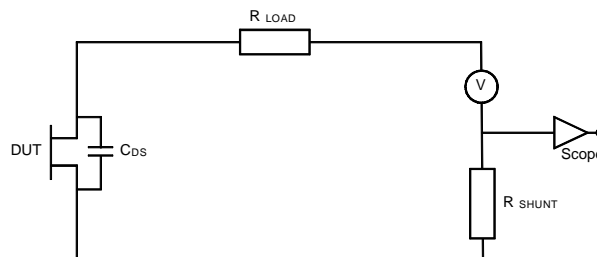

**Figure 4 – Equivalent circuit for SEB including the parasitic capacitor of the MOSFET.**

Actual resistor values for the test results presented in this report are shown in the Table 1 here below.

Symbol	Value
$R_{load}$	5,1 kohms
$R_{Shunt}$	25 ohms

**Table 1 – Test circuit resistor values**

Events are counted thanks to a programmable threshold comparator of 50MHz bandwidth. Moreover the monitoring of changes in the leakage dc current  $I_{dss}$  will allow to check for eventual permanent degradation.

Temperature effect may be evaluated as each DUT single board is provided with surface mount heating resistors and a thermistor mounted on the back side of the board, which give the ability of testing at elevated temperature.

	<b>SEE TEST REPORT</b> HRX/99.4603		Rev. -	PAGE 11 ISSUE 1 July 2, 1999
	Part Type :	SP200V	Manufacturer	SGS <b>Thomson</b>

### V.3.2 Single Event Gate Rupture (SEGR)

SEGR is a destructive effect which can be observed with the MOSFET in the off mode. Monitoring of the IGSS current allows for the detection of a SEGR which corresponds to a permanent degradation of the gate current.

This requires the measurement of  $\mu$ amp current amplitude under high impedance. Test board design is compatible with the accelerator environment by the use of a complete guard ring.

Fluence is recorded during each run by monitoring with a modular counter, the TTL signal delivered by an on-line Beam Detector. Information on the reached fluence at the time of an eventual SEGR occurrence can then be retrieved by analysis of the run data.

	<b>SEE TEST REPORT</b> HRX/99.4603		Rev. -	PAGE 12 ISSUE 1 July 2, 1999
	Part Type :	SP200V	Manufacturer	SGS Thomson

## VI. TEST FACILITIES

### VI.1 HEAVY IONS

Test at the cyclotron accelerator was performed at Université de Louvain (UCL) in Louvain la neuve (Belgium) under HIREX Engineering responsibility.

#### VI.1.1 Beam Source

In collaboration with the European Space Agency (ESA), the needed equipment for single events studies using heavy ions has been built and installed on the HIF beam line in the experimental hall of Louvain-la-Neuve cyclotron.

CYCLONE is a multi particle, variable energy, cyclotron capable of accelerating protons (up to 75 MeV), alpha particles and heavy ions. For the heavy ions, the covered energy range is between 0.6 MeV/AMU and 27.5 MeV/AMU. For these ions, the maximal energy can be determined by the formula :

$$110 Q^2/M$$

where Q is the ion charge state, and M is the mass in Atomic Mass Units.

The heavy ions are produced in a double stage Electron Cyclotron Resonance (ECR) source. Such a source allows to produce highly charged ions and ion "cocktails". These are composed of ions with the same or very close M/Q ratios. The cocktail ions are injected in the cyclotron, accelerated at the same time and extracted separately by a fine tuning of the magnetic field or a slight changing of the RF frequency. This method is very convenient for a quick change of ion (in a few minutes) which is equivalent to a LET variation.

#### VI.1.2 Beam Set-up

##### VI.1.2.1 Ion Beam Selection

The LET range was obtained by changing the ion species and incident energy and changing the angle of incidence between the beam and the chip.

For each run, information on the beam characteristics is provided in Table 2.

##### VI.1.2.2 Flux Range

For each run, the averaged flux value is provided in Table 2.

##### VI.1.2.3 Particle Fluence Levels

Fluence level was comprised between few x10E4 and 5 x10E5 ions/cm<sup>2</sup>

##### VI.1.2.4 Dosimetry

The current UCL Cyclotron dosimetry system and procedures were used.

##### VI.1.2.5 Accumulated Total Dose

For each run, the computed equivalent cumulated doses received by the DUT sample, is provided here below:

S/N	Dose (rads)
#002	3,50 E 2
#003	4,54 E 2
#004	4,54 E 2
#005	0,93 E 2
#006	0,23 E 2
#007	1,31 E 2
#009	0,68 E 2

##### VI.1.2.6 Test Temperature Range

All the tests performed were conducted at ambient temperature.

	<b>SEE TEST REPORT</b> HRX/99.4603		Rev. -	PAGE 13 ISSUE 1 July 2, 1999
	Part Type :	SP200V	Manufacturer	SGS Thomson

## VII. HEAVY IONS RESULTS

### VII.1 SP200V TEST RESULTS

Krypton and Argon ions have been used with respective LETs of 34 and 14.1 MeV/mg/cm<sup>2</sup>. Results per run are presented in Table 2. All test have been performed at ambient temperature.

Main outcomes can then be summarized as follows :

With Krypton (34 MeV/mg/cm<sup>2</sup>) and device biased with a fixed Gate Source Voltage (VGS) of -2V :

- Devices are SEB free when VDSS. does not exceed 35 % of maximum rating.
- Devices are not sensitive to SEGR (limit of the present test was 100% of VDSS).

With Argon (14.1 MeV/mg/cm<sup>2</sup>) and device biased with a fixed Gate Source Voltage (VGS) of -2V :

- Devices are SEB free when VDSS. does not exceed 80 % of maximum rating.
- Devices are not sensitive to SEGR when VDSS does not exceed 70 % of maximum rating

With Argon, when devices are tested at a VDSS rating of 50%, the maximum gate source voltage which can be applied without occurrence of SEGR event is -15V.

### VII.2 TYPICAL SEB WAVEFORM

Figure 5 show a typical example obtained with a 100V transistor. In this figure, voltage variation across R<sub>shunt</sub> can be observed for a SEB pulse waveform at two rated V<sub>DS</sub> conditions, 60V and 70V. The superposition of the simulation pulse (observed at R<sub>shunt</sub>) which consist to turn on the DUT allows to compare in each case, which part of the circuit is involved:

- In the SEB case, it can be seen that drain source voltage drops to zero in a very short time, then once the energy stored in the output DUT capacitance is dissipated, the current limitation provided by R<sub>load</sub> allows for leaving the burn-out sustaining condition and DUT output capacitance start to reload with a current limited by R<sub>load</sub>.  
The very high dV/dt (> 10 000V/μs) induce a peak current greater than 2 A, which discharge the internal C<sub>DS</sub> DUT capacitor in a few ns.
- In the case of simulation pulse, once the DUT is switched on, the supply current which flows into the DUT is limited by R<sub>load</sub>.

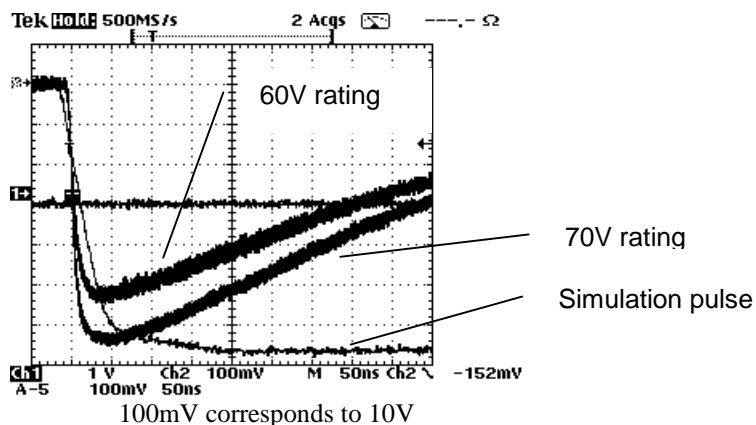

**Figure 5 – Example of non destructive SEBs observed on a 100V transistor at 60V and 70V Vds ratings**

	<b>SEE TEST REPORT</b> HRX/99.4603		Rev. -	<b>PAGE 14</b> ISSUE 1 July 2, 1999
	Part Type :	SP200V	Manufacturer	SGS <b>Thomson</b>

### VIII. CONCLUSION

SEU test have been conducted on SP200V N-channel Power MOSFET from SGS Thomson Semiconductor, using the heavy ions available at the European Heavy Ion Irradiation Facility (HIF), at Cyclone, Université Catholique de Louvain, Belgium.

With Krypton (34 MeV/mg/cm<sup>2</sup>) and device biased with a fixed Gate Source Voltage (VGS) of -2V :

- Devices are SEB free when VDSS. does not exceed 35 % of maximum rating.
- Devices are not sensitive to SEGR (limit of the present test was 100% of VDSS).

With Argon (14.1 MeV/mg/cm<sup>2</sup>) and device biased with a fixed Gate Source Voltage (VGS) of -2V :

- Devices are SEB free when VDSS. does not exceed 80 % of maximum rating.
- Devices are not sensitive to SEGR when VDSS does not exceed 70 % of maximum rating

With Argon, when devices are tested at a VDSS rating of 50%, the maximum gate source voltage which can be applied without occurrence of SEGR event is -15V.

---

**Table 2 – Heavy Ion Test results on SP200V N-Channel Power MOSFET from SGS Thomson Semiconductor :**

Run	Date	S/N	Ion	LETeff	Angle	T(°C)	VDS	VGS	%VDSS	Fluence	Flux	Time	SEB		SEGR		Comparator Threshold	Equivalent Pulse height
													Nbr	Sigma	Nbr	Sigma		
#		-	-	(MeV/mg/cm <sup>2</sup> )	(°)	(°C)	(V)	(V)	(%)	(p/cm <sup>2</sup> )	(p/cm <sup>2</sup> /s)	(s)	(-)	cm <sup>2</sup>	(-)	cm <sup>2</sup>	mV	V
VGS=-2V, Ion Krypton, LET =34 MeV/mg/cm <sup>2</sup>																		
A024	09/01/99	2	84-Kr	34	0	25	60	-2	30%	10094	1278	79,00	0				-152	-31
A025	09/01/99	2	84-Kr	34	0	25	70	-2	35%	100545	1273	79,00	0				-152	-31
B018	11/06/99	7	84-Kr	34	0	25	70	-2	35%	101610	1990	51,06	0				-248	-51
A023	09/01/99	2	84-Kr	34	0	25	80	-2	40%	101047	1263	80,00	694	6,87E-03			-152	-31
B016	11/06/99	7	84-Kr	34	0	25	80	-2	40%	101080	1810	55,85	32	3,17E-04			-248	-51
B017	11/06/99	7	84-Kr	34	0	25	90	-2	45%	37756	1800	20,98	451	1,19E-02			-248	-51
A026	09/01/99	2	84-Kr	34	0	25	100	-2	50%	100190	1237	81,00	1774	1,77E-02			-152	-31
VGS=-5V, Ion Krypton, LET =34 MeV/mg/cm <sup>2</sup>																		
B046	11/06/99	4	84-Kr	34	0	25	70	-5	35%	1090	4500	0,24	0		1	9,17E-04	-100	-20
VGS=-2V, Ion Argon, LET =14,5 MeV/mg/cm <sup>2</sup>																		
A231	10/01/99	5	40-Ar	14,1	0	25	100	-2	50%	104575	8715	12,00	0				-152	-31
A235	10/01/99	2	40-Ar	14,1	0	25	100	-2	50%	100072	6671	15,00	0				-152	-31
A239	10/01/99	3	40-Ar	14,1	0	25	100	-2	50%	500277	4810	104,00	0				-152	-31
A232	10/01/99	5	40-Ar	14,1	0	25	120	-2	60%	104687	5510	19,00	0				-152	-31
A236	10/01/99	2	40-Ar	14,1	0	25	120	-2	60%	100427	6695	15,00	0				-152	-31
A233	10/01/99	5	40-Ar	14,1	0	25	140	-2	70%	100135	5563	18,00	0				-152	-31
A237	10/01/99	2	40-Ar	14,1	0	25	140	-2	70%	100627	6708	15,00	0				-152	-31
B031	11/06/99	6	40-Ar	14,1	0	25	140	-2	70%	100000	3700	27,03	0				-100	-20
B034	11/06/99	9	40-Ar	14,1	0	25	140	-2	70%	100000	2560	39,06	0				-100	-20
A238	10/01/99	2	40-Ar	14,1	0	25	150	-2	75%	810	6513	0,12	0		1	1,23E-03	-152	-31
B035	11/06/99	9	40-Ar	14,1	0	25	150	-2	75%	6928	3230	2,15	0		1	1,44E-04	-100	-20
A234	10/01/99	5	40-Ar	14,1	0	25	160	-2	80%	500	6934	0,07	0		1	2,00E-03	-152	-31
B032	11/06/99	6	40-Ar	14,1	0	25	160	-2	80%	2000	1840	1,09	0		1	5,00E-04	-100	-20
B030	11/06/99	7	40-Ar	14,1	0	25	200	-2	100%	500	1500	0,33	2	4,00E-03	1	2,00E-03	-100	-20
VGS=-5V, Ion Argon, LET =14,5 MeV/mg/cm <sup>2</sup>																		
A240	10/01/99	3	40-Ar	14,1	0	25	100	-5	50%	501875	4253	118,00	0				-152	-31
A246	10/01/99	4	40-Ar	14,1	0	25	120	-5	60%	500355	6498	77,00	0				-152	-31
VGS=-10V, Ion Argon, LET =14,5 MeV/mg/cm <sup>2</sup>																		
A241	10/01/99	3	40-Ar	14,1	0	25	100	-10	50%	501997	4081	123,00	0				-152	-31
A244	10/01/99	4	40-Ar	14,1	0	25	100	-10	50%	505425	4637	109,00	0				-152	-31
VGS=-15V, Ion Argon, LET =14,5 MeV/mg/cm <sup>2</sup>																		
A242	10/01/99	3	40-Ar	14,1	0	25	100	-15	50%	502125	3439	146,00	0				-152	-31
A245	10/01/99	4	40-Ar	14,1	0	25	100	-15	50%	1E+06	5553	181,00	0				-152	-31
A243	10/01/99	3	40-Ar	14,1	0	25	120	-15	60%	3750	3792	0,99	0		1	2,67E-04	-152	-31