



TOTAL DOSE RADIATION TEST REPORT

Part Type : SP60

Package : TO-3

N-Channel Power MOSFET

SGS-THOMSON

Report Reference : ESA_QCA990909T_C

Issue : 01

Date : July 1st 1999

ESA Contract No 13413/98/NL/MV dated 25/01/99

European Space Agency Contract Report

The work described in this report was done under ESA contract.
Responsibility for the contents resides in the author or organization that prepared it

ESTEC Technical Officer: R. Harboe Sorensen

Hirex reference :	HRX/99.4568	Issue : 01	Date :	July 1 st 1999
Written by :	J.F. PASCAL		Date :	
Approved by :	F.X GUERRE		Date :	

TOTAL DOSE RADIATION TEST REPORT
on
SGS-Thomson SP60 N-Channel Power Mosfet.

TABLE OF CONTENTS

1	ABSTRACT.....	3
2	INTRODUCTION	4
3	APPLICABLE AND REFERENCE DOCUMENTS	4
3.1	APPLICABLE DOCUMENTS.....	4
3.2	REFERENCE DOCUMENTS	4
4	TEST SAMPLES.....	4
5	EXPERIMENTAL CONDITIONS	5
5.1	RADIATION SOURCE DOSE RATE AND ANNEALING	5
5.2	BIAS DURING DOSE EXPOSURES AND MEASUREMENTS CONDITIONS.....	5
5.2.1	Bias conditions.....	5
5.2.2	Electrical Measurements	6
6	TEST SUMMARY	8
7	TEST RESULTS	9
8	CONCLUSION.....	21
	ANNEXE 1 : SP60 DATA SHEET	22

HIREX Engineering	Total Dose Test Report		Réf. : HRX/99.4568 Issue : 01
Part Type :	SP60	Manufacturer :	SGS-THOMSON

1 Abstract

Under ESA/ESTEC contract n° 13413/98/NL/MV covering "Radiation Evaluation of Power MOSFET Devices from Different European Manufacturers", a large number of commercial Power MOSFET device types were radiation assessed. Results from these assessments, primarily focused on the radiation sensitivity of the MOSFETs to Total Ionizing Dose (TID) and Single Event Effects (SEE), are reported in individual TID and SEE reports. Below summary table list manufacturer and evaluated types, and give references to the various reports issued.

Manufacturer	Type	TID Report	SEE Report
Philips	PHP50N06T	ESA_QCA990901T_C	ESA_QCA990901S_C
Philips	BUK456-200A	ESA_QCA990902T_C	ESA_QCA990902S_C
Motorola	MTP50N06VL	ESA_QCA990903T_C	
Motorola	MTW32N20E	ESA_QCA990904T_C	
Motorola	MTP50N06V	ESA_QCA990905T_C	
SGS-Thomson	BUZ100S	ESA_QCA990906T_C	ESA_QCA990906S_C
SGS-Thomson	BUZ100SL	ESA_QCA990907T_C	ESA_QCA990907S_C
SGS-Thomson	BUZ341	ESA_QCA990908T_C	ESA_QCA990908S_C
SGS-Thomson	SP60	ESA_QCA990909T_C	ESA_QCA990909S_C
SGS-Thomson	SP100V	ESA_QCA9909010T_C	ESA_QCA9909010S_C
SGS-Thomson	SP200V	ESA_QCA9909011T_C	ESA_QCA9909011S_C
SGS-Thomson	SPP1N60S5	ESA_QCA9909012T_C	ESA_QCA9909012S_C
Philips	BUK7508-55	ESA_QCA9909013T_C	ESA_QCA9909013S_C
Harris	HUF75639P3	ESA_QCA9909014T_C	ESA_QCA9909014S_C

HIREX Engineering	Total Dose Test Report		Réf. : HRX/99.4568 Issue : 01
Part Type :	SP60	Manufacturer :	SGS-THOMSON

2 Introduction

A total dose radiation evaluation test of the SGS-THOMSON SP60 N-Channel Power Mosfet has been performed with an accumulated dose of about 37 Krad(Si) at a dose rate of 75 rad(Si)/hour, in response to European Space Agency contract reference : 13413/98/NL/MV.

The purpose of this test was to evaluate total dose withstanding of this component, to investigate its suitability for being used in space applications. This test was conducted on commercial samples provided by ESTEC.

Test has been performed in accordance with Hirex proposal HRX/98.3475 issue 01.

A complete set of electrical measurements together with graphical representation of measured parameters with respect to total dose received, are provided for all samples.

SEE results for this device type can be found in SEE radiation test report: ESA_QCA990909S_C

3 Applicable and Reference Documents

3.1 Applicable Documents

- ESA/SCC Basic specification N° 22900 issue 4
- SGS-Thomson datasheet (See Annex)
- Hirex Engineering proposal: HRX/98.3475 issue 01.

3.2 Reference Documents

- MIL-STD-883: test methods and procedures for microcircuits

4 Test Samples

11 samples of the SP60 device, provided in TO-3 package , were tested (2 groups of 5 + 1 control sample). Samples were already serialized when received at Hirex. For the purpose of this evaluation, sample identification was reallocated in order to be consistent with the other types under evaluation, and considering parts used for heavy ions test. The correspondence is provided in the following table.

Old identification	New identification	Allocation
1	1	Control
2	2	Bias 1
3	3	Bias 1
4	4	Bias 1
5	5	Bias 1
7	6	Bias 1
8	7	Bias 2
9	8	Bias 2
10	9	Bias 2
11	10	Bias 2
12	11	Bias 2

Identification of the SP60 is given below:

Part Number:	SP60	Mask Set:	NA
Top Marking:	39822 SP60	Chip Marking:	NA
Diffusion Lot:	NA	Wafer #:	NA
Date Code:	9822	Project:	Not defined

HIREX Engineering	Total Dose Test Report		Réf. : HRX/99.4568 Issue : 01
Part Type :	SP60	Manufacturer :	SGS-THOMSON

5 Experimental Conditions

5.1 Radiation Source Dose Rate and Annealing

The dose exposures were performed at CERT-ONERA. In this irradiation facility, a Cobalt 60 source is used with the possibility to vary the dose rate by simply adjusting the distance to the source. The irradiation conditions used for this test are provided in the following table:

Irradiation Steps	Dose rate	Annealing steps	Temperature
krads	krads/h	hours	°C
0			
3.85	0,075		25
7.35	0,075		25
13.95	0,075		25
19.65	0,075		25
24.65	0,075		25
29.85	0,075		25
36.85	0,075	0	25
		24	25
		192	100

5.2 Bias during Dose Exposures and Measurements conditions

5.2.1 Bias conditions

During exposures dedicated test boards were used mounted on a special board-holder made for irradiation. The test board allowed to bias the devices in accordance with the electrical circuit provided in Figure 1. Two bias conditions were used so called Bias 1 and Bias 2.

Bias 1 corresponds to a gate stress of V_{GS} equals 12 Volts. Bias 2 corresponds to drain to source stress equals 80% of $BVDSS$.

During annealing steps the same stress conditions were applied at room and 100°C temperatures respectively.

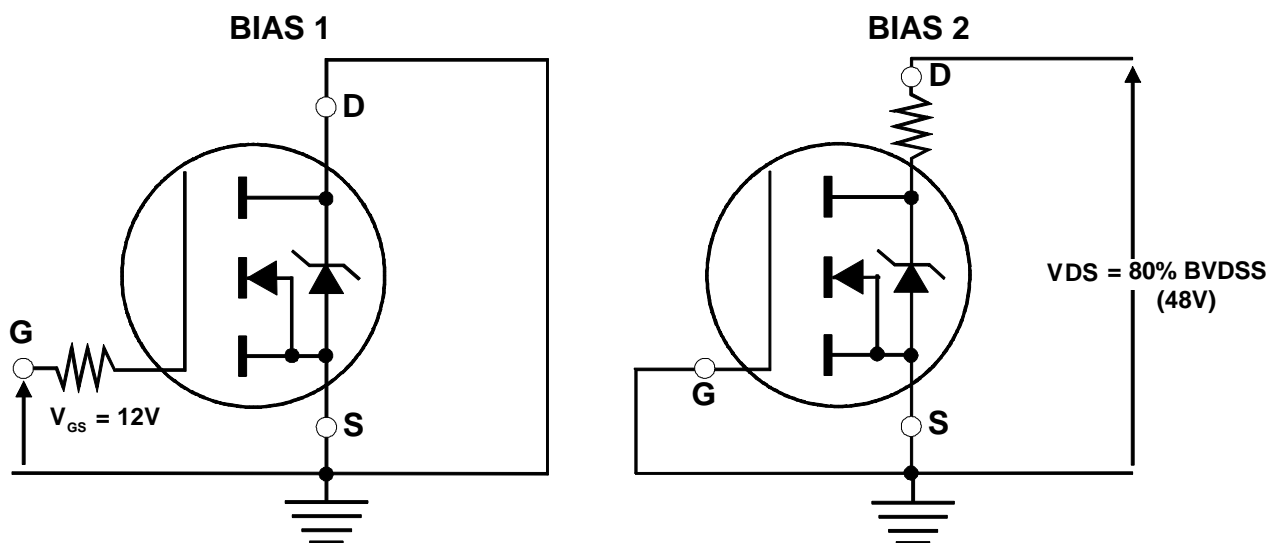

Figure 1 : Bias Conditions during Irradiation Exposures and Annealing

HIREX Engineering	Total Dose Test Report		Réf. : HRX/99.4568 Issue : 01
Part Type :	SP60	Manufacturer :	SGS-THOMSON

5.2.2 Electrical Measurements

Mosfet transistor test program principle is provided in Figure 2. Due to the great number of samples to be measured (test campaign was conducted on 14 part types at the same time) and the time interval constraints required for performing measurements after each exposure and annealing step, It was decided to automate low power and high power measurements.

Two instruments were used to cover low power and high power measurements respectively. HP4142B was used for breakdown voltage, gate and drain leakage currents, and threshold voltage measurements.

Tektronix TEK371 high power curve tracer was used for $R_{DS(ON)}$ measurements.

A dedicated test fixture was designed to ensure proper switching of instruments. In addition a faraday cup was used to ensure optimum conditions for low level measurements.

Test program has been written in Visual Basic on a PC computer. GPIB commands were sent to each instrument via IEEE bus, in order to measure a given parameter with specified conditions. Results were automatically loaded in an Excel worksheet and compared in real time to specification limits. This allowed for real time data analysis in particular when failures were recorded.

Figure 2 : Mosfet transistor test program principle

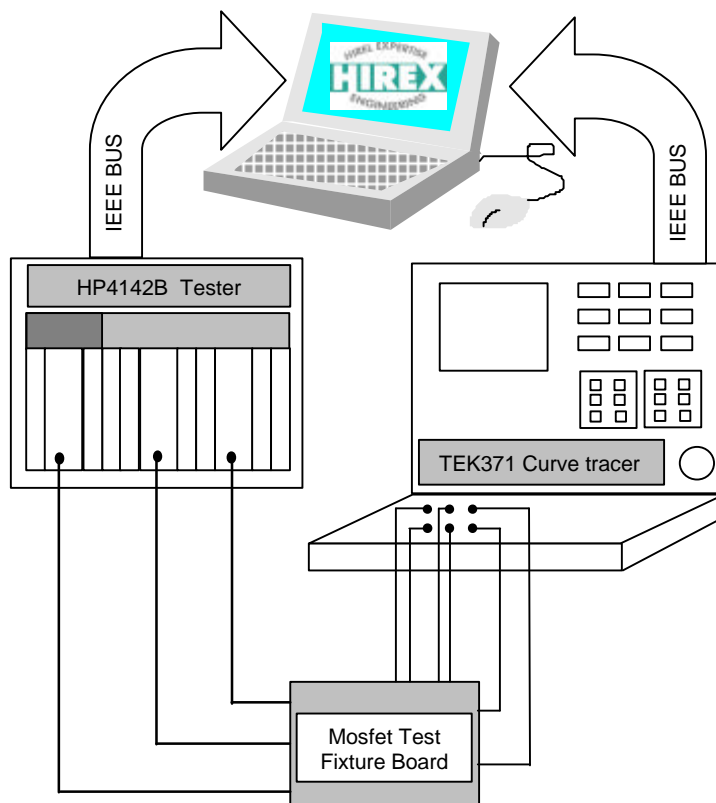

HIREX Engineering	Total Dose Test Report		Réf. : HRX/99.4568 Issue : 01
Part Type :	SP60	Manufacturer :	SGS-THOMSON

Electrical parameters test conditions and limits used for performing this test are given in the following table.

Symbol	Test Parameter	Test Conditions	Min limit	Max limit	Unit
BVDSS	Drain to Source breakdown voltage	VGS=0V, ID=0.25mA	60		V
VGSTH	Gate to Source threshold voltage	VDS>=VGS, ID=0.25mA	2	4	V
+IGSS	Positive Gate Source leakage current	VGS=+20V, VDS=0V		100	nA
-IGSS	Negative Gate Source leakage current	VGS=-20V, VDS=0V		100	nA
IDSS	Drain current	VGS=0V, VDS=60V		1	μA
RDSON	Static drain to source on-state resistance	VGS=10V, ID=27.5A		0.022	Ohm

Table 1 : Measured electrical parameters

HIREX Engineering	Total Dose Test Report		Réf. : HRX/99.4568 Issue : 01
Part Type :	SP60	Manufacturer :	SGS-THOMSON

6 Test Summary

A Total Ionizing Dose assessment was carried out by Hirex Engineering under ESA contract on the SGS-Thomson SP60 N-Channel Power Mosfet.

2 groups of 5 samples each plus one control sample were used during testing. The first group was exposed to radiation using Bias 1 conditions corresponding to a gate stress of the devices. The second group of 5 samples was exposed to radiation using Bias 2 conditions corresponding to drain to source stress of the devices, equals 80% of BVDSS (48 Volts).

Based on the analysis of the results, the tolerances of this component and main conclusion are provided below.

Parametric Tolerance Level (\geq Krad) - Bias 1: 36.85 [1]

Parametric Tolerance Level (\geq Krad) - Bias 2: 13.95

Parametric tolerance level represents the last cumulative exposure at which no samples failed any test

[1] : IGSS under Bias 1 conditions out of specification at initial readings.

Main conclusion:

Breakdown voltage is out of specification limit at 19.65 Krad(Si) under Bias 2 conditions, and did not recover for subsequent steps.

IDSS, under Bias 2 conditions, increases significantly for most samples and up to the compliance value of 50mA (for one sample) at a dose level of 19.65 Krad(Si), without further recovery.

HIREX Engineering	Total Dose Test Report			Réf. : HRX/99.4568 Issue : 01
Part Type :	SP60	Manufacturer :	SGS-THOMSON	

7 Test Results

Test results including tables and graphics are provided in this section for each measured parameter. To allow easy reading of data, each parameter is plotted twice, one for the first bias condition: Bias 1 and one for the second condition: Bias 2.

Parameter: Drain to source breakdown voltage: BVDSS-Bias1 VGS=0V, ID=0.25mA

Unit= V

Spec limit min: 60

Spec limits are represented in bold lines on the graphic.

Test Step	Initial	3,85 krad	7,35 krad	13,95 krad	19,65 krad	24,65 krad	29,85 krad
Serial #							
1 Ref.	7,195E +01	7,196E +01	7,186E +01	7,224E +01	7,208E +01	7,203E +01	7,196E +01
2	7,432E +01	7,453E +01	7,401E +01	7,219E +01	7,102E +01	6,992E +01	6,929E +01
3	7,094E +01	7,113E +01	7,094E +01	7,089E +01	7,072E +01	6,954E +01	6,898E +01
4	7,236E +01	7,249E +01	7,291E +01	7,019E +01	6,992E +01	6,882E +01	6,799E +01
5	7,170E +01	7,182E +01	7,177E +01	7,174E +01	7,165E +01	7,039E +01	6,972E +01
6	7,252E +01	7,267E +01	7,259E +01	7,257E +01	7,180E +01	7,083E +01	7,026E +01
Statistics							
Min	7,094E +01	7,113E +01	7,094E +01	7,019E +01	6,992E +01	6,882E +01	6,799E +01
Max	7,432E +01	7,453E +01	7,401E +01	7,257E +01	7,180E +01	7,083E +01	7,026E +01
Mean	7,237E +01	7,253E +01	7,244E +01	7,152E +01	7,102E +01	6,990E +01	6,925E +01
Sigma	1,259E +00	1,272E +00	1,165E +00	9,704E -01	7,602E -01	7,727E -01	8,522E -01

Test Step	36,85 krad	24 hours	192 hours
Serial #			
1 Ref.	7,200E +01	7,206E +01	7,202E +01
2	6,849E +01	6,840E +01	6,851E +01
3	6,795E +01	6,839E +01	6,857E +01
4	6,746E +01	6,720E +01	6,736E +01
5	6,852E +01	6,879E +01	6,891E +01
6	6,916E +01	6,936E +01	6,954E +01
Statistics			
Min	6,746E +01	6,720E +01	6,736E +01
Max	6,916E +01	6,936E +01	6,954E +01
Mean	6,831E +01	6,842E +01	6,858E +01
Sigma	6,428E -01	7,906E -01	7,959E -01

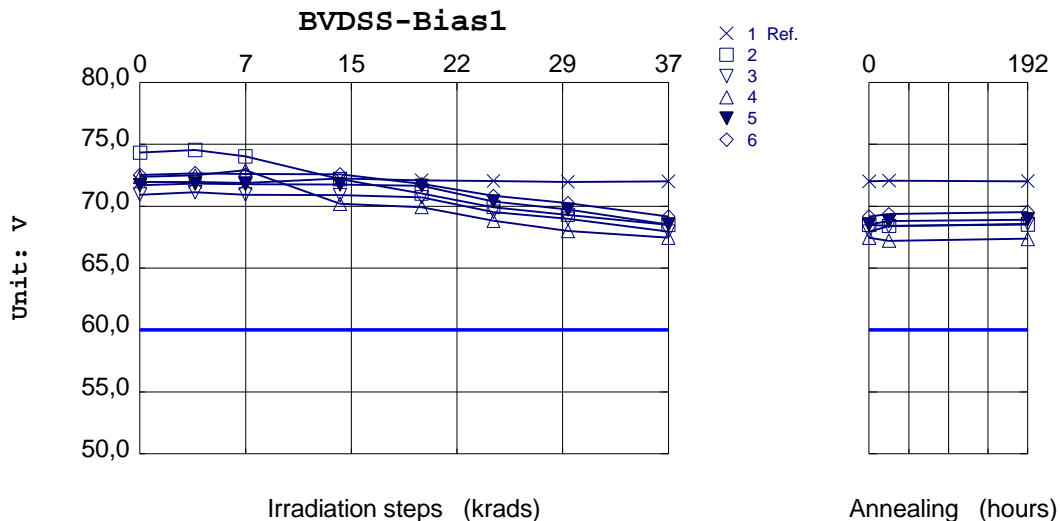

HIREX Engineering	Total Dose Test Report			Réf. : HRX/99.4568 Issue : 01
Part Type :	SP60	Manufacturer :	SGS-THOMSON	

Parameter: Drain to source breakdown voltage: BVDSS-Bias2 VGS=0V, ID=0.25mA

Unit= V

Spec limit min: 60

Spec limits are represented in bold lines on the graphic.

Test Step	Initial	3,85 krad	7,35 krad	13,95 krad	19,65 krad	24,65 krad	29,85 krad
Serial #							
1 Ref.	7,195E +01	7,196E +01	7,186E +01	7,224E +01	7,208E +01	7,203E +01	7,196E +01
7	7,427E +01	7,242E +01	6,895E +01	6,400E +01	6,105E +01	5,866E +01	5,707E +01
8	7,103E +01	7,111E +01	6,858E +01	6,396E +01	6,103E +01	5,871E +01	5,715E +01
9	7,115E +01	6,871E +01	6,559E +01	6,184E +01	5,901E +01	5,713E +01	5,564E +01
10	7,412E +01	7,298E +01	6,970E +01	6,470E +01	6,179E +01	5,935E +01	5,753E +01
11	6,927E +01	6,943E +01	6,694E +01	6,242E +01	5,970E +01	5,765E +01	5,615E +01
Statistics							
Min	6,927E +01	6,871E +01	6,559E +01	6,184E +01	5,901E +01	5,713E +01	5,564E +01
Max	7,427E +01	7,298E +01	6,970E +01	6,470E +01	6,179E +01	5,935E +01	5,753E +01
Mean	7,197E +01	7,093E +01	6,795E +01	6,338E +01	6,052E +01	5,830E +01	5,671E +01
Sigma	2,164E +00	1,844E +00	1,663E +00	1,201E +00	1,131E +00	8,944E -01	7,835E -01

Test Step	36,85 krad	24 hours	192 hours
Serial #			
1 Ref.	7,200E +01	7,206E +01	7,202E +01
7	5,527E +01	5,643E +01	5,650E +01
8	5,538E +01	5,654E +01	5,659E +01
9	5,406E +01	5,524E +01	5,530E +01
10	5,566E +01	5,653E +01	5,674E +01
11	5,460E +01	5,550E +01	5,568E +01
Statistics			
Min	5,406E +01	5,524E +01	5,530E +01
Max	5,566E +01	5,654E +01	5,674E +01
Mean	5,499E +01	5,605E +01	5,616E +01
Sigma	6,515E -01	6,239E -01	6,333E -01

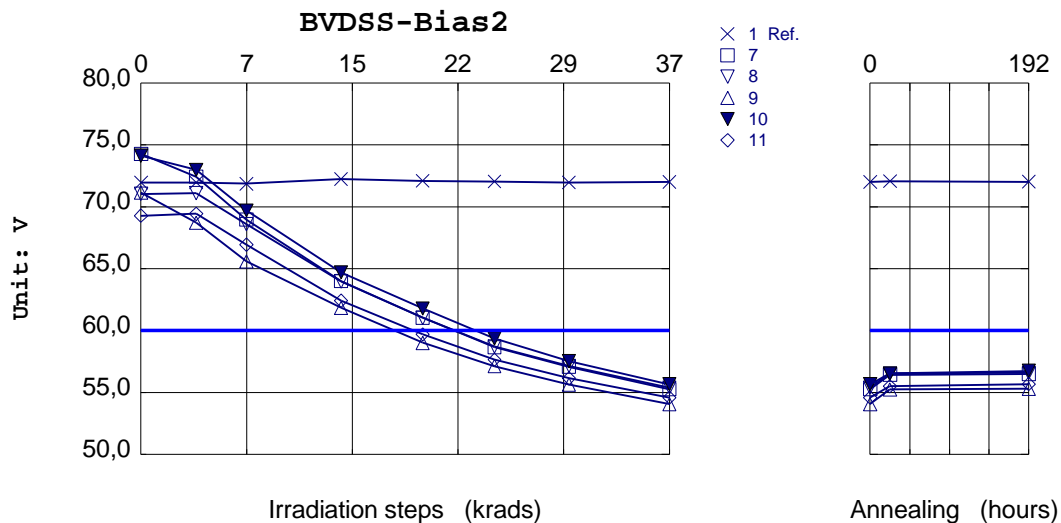

HIREX Engineering	Total Dose Test Report			Réf. : HRX/99.4568
				Issue : 01
Part Type :	SP60	Manufacturer :	SGS-THOMSON	

Parameter: Gate to source threshold voltage: VGSTH-Bias1 VDS>=VGS, ID=0.25mA

Unit= V

Spec limit max: 4

Spec limit min: 2

Spec limits are represented in bold lines on the graphic.

Test Step	Initial	3,85 krad	7,35 krad	13,95 krad	19,65 krad	24,65 krad	29,85 krad
Serial #							
1 Ref.	3,274E +00	3,271E +00	3,286E +00	3,260E +00	3,277E +00	3,269E +00	3,281E +00
2	3,204E +00	3,135E +00	3,113E +00	3,016E +00	2,936E +00	2,862E +00	2,809E +00
3	3,280E +00	3,228E +00	3,174E +00	3,105E +00	2,980E +00	2,950E +00	2,847E +00
4	3,117E +00	3,072E +00	3,019E +00	2,956E +00	2,842E +00	2,809E +00	2,731E +00
5	3,273E +00	3,218E +00	3,159E +00	3,093E +00	2,975E +00	2,929E +00	2,838E +00
6	3,262E +00	3,190E +00	3,141E +00	3,062E +00	2,965E +00	2,903E +00	2,826E +00
Statistics							
Min	3,117E +00	3,072E +00	3,019E +00	2,956E +00	2,842E +00	2,809E +00	2,731E +00
Max	3,280E +00	3,228E +00	3,174E +00	3,105E +00	2,980E +00	2,950E +00	2,847E +00
Mean	3,227E +00	3,169E +00	3,121E +00	3,046E +00	2,940E +00	2,891E +00	2,810E +00
Sigma	6,817E -02	6,503E -02	6,137E -02	6,119E -02	5,719E -02	5,627E -02	4,641E -02

Test Step	36,85 krad	24 hours	192 hours
Serial #			
1 Ref.	3,279E +00	3,267E +00	3,272E +00
2	2,736E +00	2,725E +00	2,888E +00
3	2,799E +00	2,772E +00	2,961E +00
4	2,672E +00	2,664E +00	2,818E +00
5	2,777E +00	2,751E +00	2,960E +00
6	2,752E +00	2,735E +00	2,951E +00
Statistics			
Min	2,672E +00	2,664E +00	2,818E +00
Max	2,799E +00	2,772E +00	2,961E +00
Mean	2,747E +00	2,730E +00	2,916E +00
Sigma	4,824E -02	4,072E -02	6,239E -02

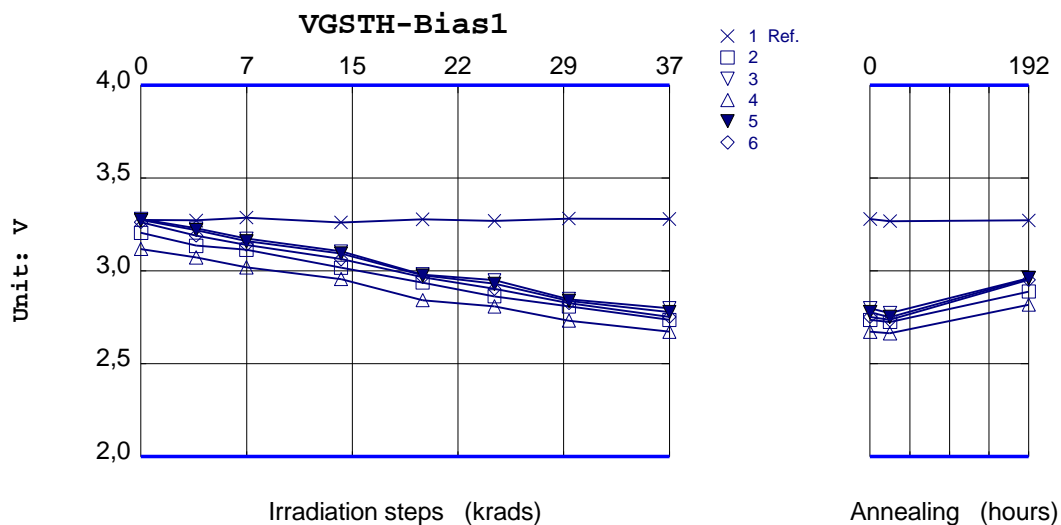

HIREX Engineering	Total Dose Test Report			Réf. : HRX/99.4568
				Issue : 01
Part Type :	SP60	Manufacturer :	SGS-THOMSON	

Parameter: Gate to source threshold voltage: VGSTH-Bias2 VDS>=VGS,ID=0.25mA

Unit= V

Spec limit max: 4

Spec limit min: 2

Spec limits are represented in bold lines on the graphic.

Test Step	Initial	3,85 krad	7,35 krad	13,95 krad	19,65 krad	24,65 krad	29,85 krad
Serial #							
1 Ref.	3,274E +00	3,271E +00	3,286E +00	3,260E +00	3,277E +00	3,269E +00	3,281E +00
7	3,208E +00	3,132E +00	3,110E +00	3,036E +00	2,974E +00	2,951E +00	2,879E +00
8	3,316E +00	3,257E +00	3,212E +00	3,135E +00	3,073E +00	3,012E +00	2,967E +00
9	3,127E +00	3,061E +00	3,013E +00	2,968E +00	2,881E +00	2,836E +00	2,803E +00
10	3,173E +00	3,113E +00	3,095E +00	3,010E +00	2,958E +00	2,904E +00	2,848E +00
11	3,269E +00	3,175E +00	3,143E +00	3,094E +00	2,991E +00	2,958E +00	2,902E +00
Statistics							
Min	3,127E +00	3,061E +00	3,013E +00	2,968E +00	2,881E +00	2,836E +00	2,803E +00
Max	3,316E +00	3,257E +00	3,212E +00	3,135E +00	3,073E +00	3,012E +00	2,967E +00
Mean	3,219E +00	3,148E +00	3,115E +00	3,049E +00	2,976E +00	2,932E +00	2,880E +00
Sigma	7,523E -02	7,376E -02	7,241E -02	6,648E -02	6,859E -02	6,598E -02	6,123E -02

Test Step	36,85 krad	24 hours	192 hours
Serial #			
1 Ref.	3,279E +00	3,267E +00	3,272E +00
7	2,822E +00	2,804E +00	3,224E +00
8	2,888E +00	2,855E +00	3,332E +00
9	2,708E +00	2,689E +00	3,125E +00
10	2,794E +00	2,762E +00	3,155E +00
11	2,818E +00	2,805E +00	3,299E +00
Statistics			
Min	2,708E +00	2,689E +00	3,125E +00
Max	2,888E +00	2,855E +00	3,332E +00
Mean	2,806E +00	2,783E +00	3,227E +00
Sigma	6,492E -02	6,202E -02	8,876E -02

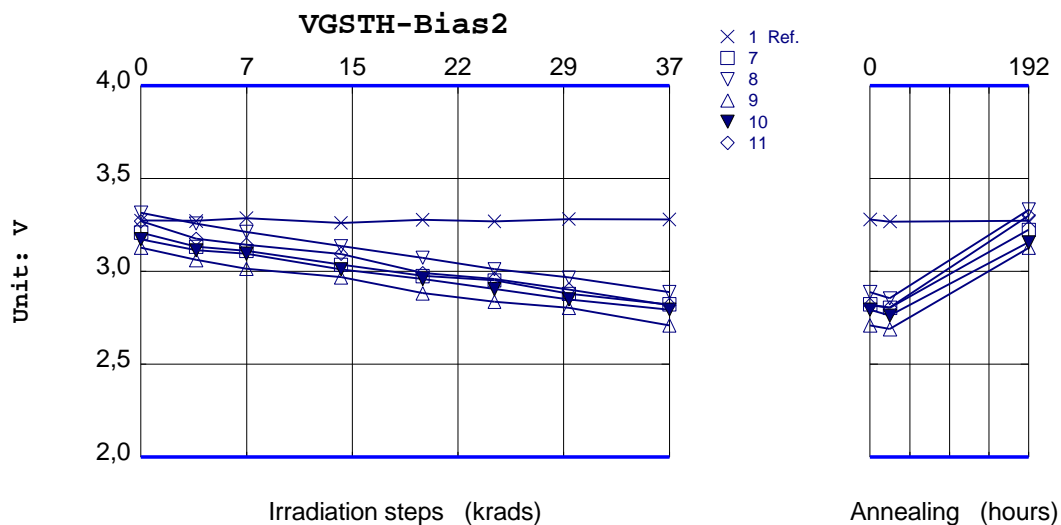

HIREX Engineering	Total Dose Test Report			Réf. : HRX/99.4568
				Issue : 01
Part Type :	SP60	Manufacturer :	SGS-THOMSON	

Parameter: Positive Gate source leakage current: +IGSS-Bias1 VGS=+20V, VDS=0V

Unit= A

Spec limit max: 100E-9

Spec limits are represented in bold lines on the graphic.

Test Step	Initial	3,85 krad	7,35 krad	13,95 krad	19,65 krad	24,65 krad	29,85 krad
Serial #							
1 Ref.	1,470E -10	1,748E -10	1,681E -10	1,642E -10	1,561E -10	1,754E -10	1,558E -10
2	6,676E -10	1,443E -10	1,331E -10	1,981E -10	1,512E -10	1,629E -10	1,676E -10
3	6,676E -10	1,537E -10	1,094E -10	1,799E -10	1,355E -10	1,438E -10	1,588E -10
4	6,365E -10	1,323E -10	1,290E -10	1,966E -10	1,594E -10	1,530E -10	1,549E -10
5	6,676E -10	1,317E -10	9,574E -11	2,063E -10	1,704E -10	1,653E -10	1,502E -10
6	6,765E -10	1,371E -10	1,145E -10	1,985E -10	1,645E -10	1,663E -10	1,432E -10
Statistics							
Min	6,365E -10	1,317E -10	9,574E -11	1,799E -10	1,355E -10	1,438E -10	1,432E -10
Max	6,765E -10	1,537E -10	1,331E -10	2,063E -10	1,704E -10	1,663E -10	1,676E -10
Mean	6,632E -10	1,398E -10	1,164E -10	1,959E -10	1,562E -10	1,583E -10	1,549E -10
Sigma	1,539E -11	9,275E -12	1,515E -11	9,686E -12	1,356E -11	9,641E -12	9,139E -12

Test Step	36,85 krad	24 hours	192 hours
Serial #			
1 Ref.	1,376E -10	1,312E -10	1,437E -10
2	1,119E -10	1,273E -10	1,313E -10
3	1,237E -10	1,210E -10	1,091E -10
4	1,193E -10	1,178E -10	1,332E -10
5	1,482E -10	1,382E -10	1,414E -10
6	1,351E -10	1,250E -10	9,144E -11
Statistics			
Min	1,119E -10	1,178E -10	9,144E -11
Max	1,482E -10	1,382E -10	1,414E -10
Mean	1,277E -10	1,259E -10	1,213E -10
Sigma	1,423E -11	7,823E -12	2,053E -11

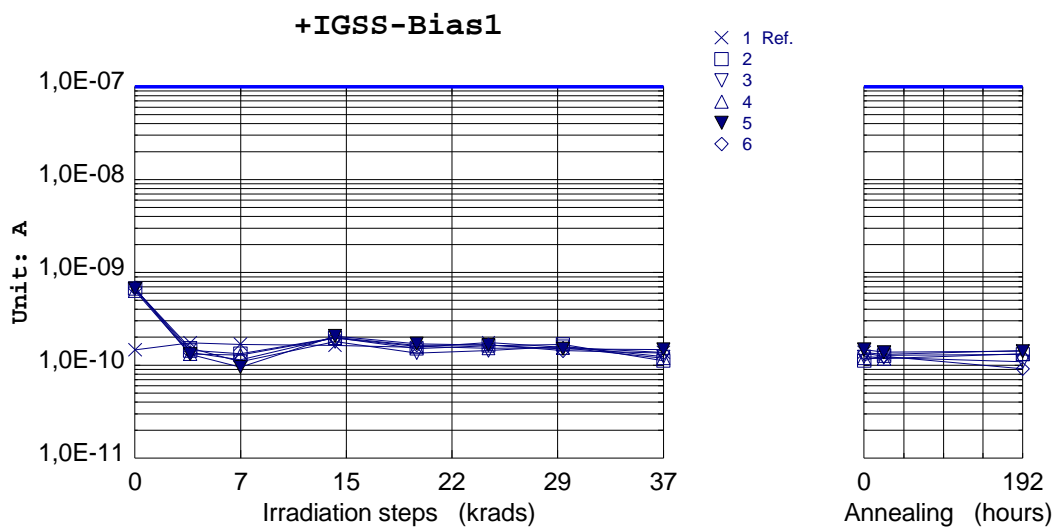

HIREX Engineering	Total Dose Test Report			Réf. : HRX/99.4568
				Issue : 01
Part Type :	SP60	Manufacturer :	SGS-THOMSON	

Parameter: Positive Gate source leakage current: +IGSS-Bias2 VGS=+20V, VDS=0V

Unit= A

Spec limit max: 100E-9

Spec limits are represented in bold lines on the graphic.

Test Step	Initial	3,85 krad	7,35 krad	13,95 krad	19,65 krad	24,65 krad	29,85 krad
Serial #							
1 Ref.	1,470E -10	1,748E -10	1,681E -10	1,642E -10	1,561E -10	1,754E -10	1,558E -10
7	6,656E -10	1,392E -10	1,747E -10	2,071E -10	1,256E -10	1,476E -10	1,431E -10
8	6,307E -10	1,802E -10	1,167E -10	1,888E -10	1,340E -10	1,416E -10	1,333E -10
9	6,485E -10	2,074E -10	1,435E -10	1,898E -10	1,540E -10	1,672E -10	1,336E -10
10	6,400E -10	1,376E -10	1,131E -10	1,812E -10	1,190E -10	1,389E -10	1,331E -10
11	6,474E -10	1,270E -10	1,459E -10	1,843E -10	1,453E -10	1,538E -10	1,513E -10
Statistics							
Min	6,307E -10	1,270E -10	1,131E -10	1,812E -10	1,190E -10	1,389E -10	1,331E -10
Max	6,656E -10	2,074E -10	1,747E -10	2,071E -10	1,540E -10	1,672E -10	1,513E -10
Mean	6,464E -10	1,583E -10	1,388E -10	1,902E -10	1,356E -10	1,498E -10	1,389E -10
Sigma	1,289E -11	3,415E -11	2,504E -11	1,004E -11	1,422E -11	1,130E -11	8,154E -12

Test Step	36,85 krad	24 hours	192 hours
Serial #			
1 Ref.	1,376E -10	1,312E -10	1,437E -10
7	1,590E -10	1,332E -10	1,286E -10
8	1,234E -10	1,296E -10	1,313E -10
9	1,202E -10	1,179E -10	1,429E -10
10	1,404E -10	1,112E -10	1,128E -10
11	1,255E -10	1,194E -10	1,288E -10
Statistics			
Min	1,202E -10	1,112E -10	1,128E -10
Max	1,590E -10	1,332E -10	1,429E -10
Mean	1,337E -10	1,222E -10	1,289E -10
Sigma	1,611E -11	9,007E -12	1,076E -11

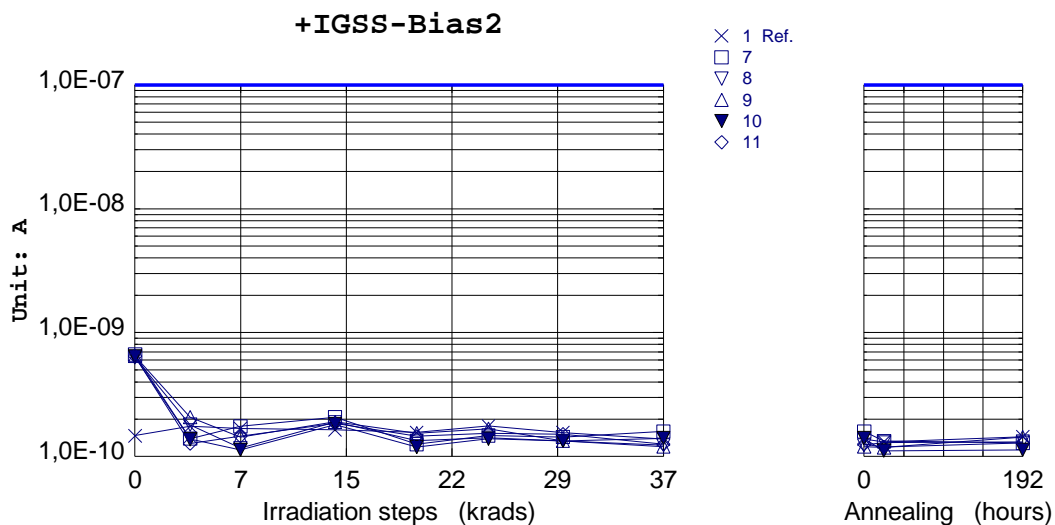

HIREX Engineering	Total Dose Test Report			Réf. : HRX/99.4568
				Issue : 01
Part Type :	SP60	Manufacturer :	SGS-THOMSON	

Parameter: Negative Gate source leakage current: -IGSS-Bias1 VGS=-20V, VDS=0V

Unit= A

Spec limit max: 100E-9

Spec limits are represented in bold lines on the graphic.

Test Step	Initial	3,85 krad	7,35 krad	13,95 krad	19,65 krad	24,65 krad	29,85 krad
Serial #							
1 Ref.	4,171E -08	4,472E -08	4,018E -08	4,249E -08	4,529E -08	4,170E -08	4,089E -08
2	1,824E -07	1,285E -07	1,028E -07	8,233E -08	7,310E -08	6,423E -08	5,991E -08
3	1,795E -07	1,257E -07	9,045E -08	7,578E -08	6,784E -08	6,112E -08	5,623E -08
4	2,281E -07	1,568E -07	1,257E -07	1,102E -07	1,023E -07	8,430E -08	7,544E -08
5	1,677E -07	1,175E -07	8,443E -08	7,138E -08	6,347E -08	5,674E -08	5,278E -08
6	1,579E -07	1,101E -07	7,921E -08	6,754E -08	6,057E -08	5,407E -08	5,048E -08
Statistics							
Min	1,579E -07	1,101E -07	7,921E -08	6,754E -08	6,057E -08	5,407E -08	5,048E -08
Max	2,281E -07	1,568E -07	1,257E -07	1,102E -07	1,023E -07	8,430E -08	7,544E -08
Mean	1,831E -07	1,277E -07	9,651E -08	8,144E -08	7,346E -08	6,409E -08	5,897E -08
Sigma	2,697E -08	1,776E -08	1,852E -08	1,698E -08	1,681E -08	1,196E -08	9,876E -09

Test Step	36,85 krad	24 hours	192 hours
Serial #			
1 Ref.	4,037E -08	3,866E -08	3,973E -08
2	5,606E -08	4,800E -08	5,215E -08
3	5,377E -08	4,590E -08	4,956E -08
4	7,039E -08	6,043E -08	6,533E -08
5	5,064E -08	4,335E -08	4,631E -08
6	4,822E -08	4,127E -08	4,452E -08
Statistics			
Min	4,822E -08	4,127E -08	4,452E -08
Max	7,039E -08	6,043E -08	6,533E -08
Mean	5,581E -08	4,779E -08	5,157E -08
Sigma	8,675E -09	7,511E -09	8,231E -09

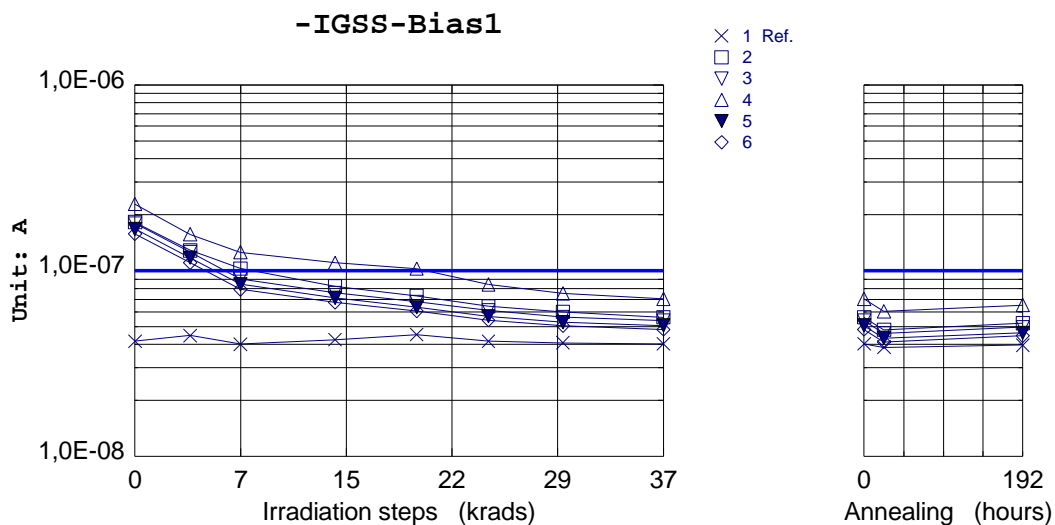

HIREX Engineering	Total Dose Test Report			Réf. : HRX/99.4568
				Issue : 01
Part Type :	SP60	Manufacturer :	SGS-THOMSON	

Parameter: Negative Gate source leakage current: -IGSS-Bias2 VGS=-20V, VDS=0V

Unit= A

Spec limit max: 100E-9

Spec limits are represented in bold lines on the graphic.

Test Step	Initial	3,85 krad	7,35 krad	13,95 krad	19,65 krad	24,65 krad	29,85 krad
Serial #							
1 Ref.	4,171E -08	4,472E -08	4,018E -08	4,249E -08	4,529E -08	4,170E -08	4,089E -08
7	1,768E -07	1,511E -07	1,473E -07	1,731E -07	1,854E -07	1,897E -07	1,951E -07
8	1,752E -07	1,506E -07	1,479E -07	1,714E -07	1,892E -07	1,910E -07	1,975E -07
9	2,097E -07	1,758E -07	1,725E -07	1,952E -07	2,176E -07	2,203E -07	2,268E -07
10	2,105E -07	1,785E -07	1,731E -07	1,996E -07	2,172E -07	2,209E -07	2,258E -07
11	2,055E -07	1,728E -07	1,690E -07	1,979E -07	2,132E -07	2,144E -07	2,169E -07
Statistics							
Min	1,752E -07	1,506E -07	1,473E -07	1,714E -07	1,854E -07	1,897E -07	1,951E -07
Max	2,105E -07	1,785E -07	1,731E -07	1,996E -07	2,176E -07	2,209E -07	2,268E -07
Mean	1,956E -07	1,657E -07	1,619E -07	1,875E -07	2,045E -07	2,073E -07	2,124E -07
Sigma	1,795E -08	1,374E -08	1,320E -08	1,395E -08	1,588E -08	1,566E -08	1,522E -08

Test Step	36,85 krad	24 hours	192 hours
Serial #			
1 Ref.	4,037E -08	3,866E -08	3,973E -08
7	2,152E -07	1,701E -07	1,770E -07
8	2,147E -07	1,680E -07	1,771E -07
9	2,484E -07	1,919E -07	2,005E -07
10	2,480E -07	1,926E -07	2,034E -07
11	2,412E -07	1,867E -07	1,932E -07
Statistics			
Min	2,147E -07	1,680E -07	1,770E -07
Max	2,484E -07	1,926E -07	2,034E -07
Mean	2,335E -07	1,819E -07	1,902E -07
Sigma	1,719E -08	1,196E -08	1,260E -08

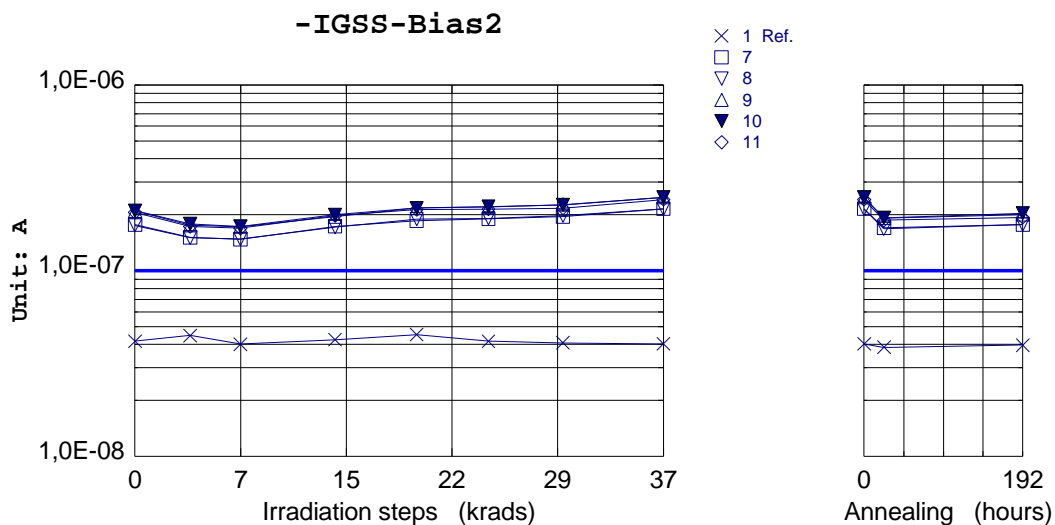

HIREX Engineering	Total Dose Test Report			Réf. : HRX/99.4568 Issue : 01
Part Type :	SP60	Manufacturer :	SGS-THOMSON	

Parameter: Drain current: IDSS-Bias1 VGS=0V, VDS=60V

Unit= A

Spec limit max: 1E-6

Spec limits are represented in bold lines on the graphic.

Test Step	Initial	3,85 krad	7,35 krad	13,95 krad	19,65 krad	24,65 krad	29,85 krad
Serial #							
1 Ref.	4,465E -08	4,029E -08	5,166E -08	4,342E -08	4,571E -08	4,120E -08	3,612E -08
2	1,104E -09	8,263E -10	1,362E -09	2,433E -09	4,287E -09	4,445E -09	5,716E -09
3	1,172E -09	1,012E -09	1,420E -09	2,604E -09	4,509E -09	4,873E -09	6,022E -09
4	1,138E -09	7,621E -10	1,284E -09	2,486E -09	4,000E -09	4,302E -09	5,114E -09
5	2,636E -09	8,597E -10	1,443E -09	2,691E -09	4,426E -09	4,689E -09	5,703E -09
6	1,148E -09	8,591E -10	1,445E -09	2,649E -09	4,371E -09	4,708E -09	5,726E -09
Statistics							
Min	1,104E -09	7,621E -10	1,284E -09	2,433E -09	4,000E -09	4,302E -09	5,114E -09
Max	2,636E -09	1,012E -09	1,445E -09	2,691E -09	4,509E -09	4,873E -09	6,022E -09
Mean	1,440E -09	8,639E -10	1,391E -09	2,573E -09	4,319E -09	4,603E -09	5,656E -09
Sigma	6,691E -10	9,194E -11	6,853E -11	1,093E -10	1,954E -10	2,276E -10	3,311E -10

Test Step	36,85 krad	24 hours	192 hours
Serial #			
1 Ref.	3,756E -08	2,859E -08	3,663E -08
2	5,452E -09	5,773E -09	3,828E -09
3	6,037E -09	6,225E -09	4,238E -09
4	5,128E -09	5,406E -09	3,865E -09
5	5,933E -09	6,207E -09	4,251E -09
6	5,862E -09	6,356E -09	4,073E -09
Statistics			
Min	5,128E -09	5,406E -09	3,828E -09
Max	6,037E -09	6,356E -09	4,251E -09
Mean	5,682E -09	5,994E -09	4,051E -09
Sigma	3,814E -10	3,950E -10	2,000E -10

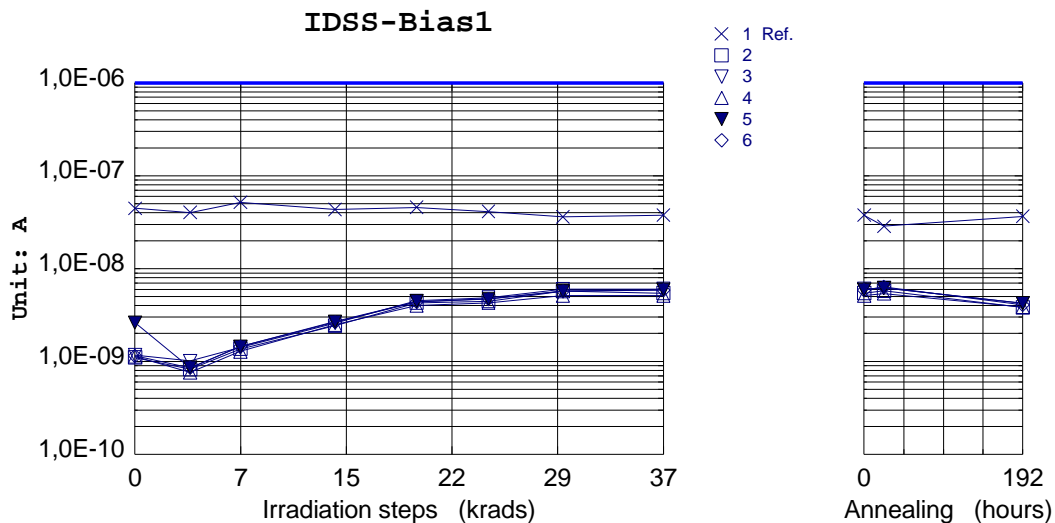

HIREX Engineering	Total Dose Test Report			Réf. : HRX/99.4568
				Issue : 01
Part Type :	SP60	Manufacturer :	SGS-THOMSON	

Parameter: Drain current: IDSS-Bias2 VGS=0V, VDS=60V

Unit= A

Spec limit max: 1E-6

Spec limits are represented in bold lines on the graphic.

Test Step	Initial	3,85 krad	7,35 krad	13,95 krad	19,65 krad	24,65 krad	29,85 krad
Serial #							
1 Ref.	4,465E -08	4,029E -08	5,166E -08	4,342E -08	4,571E -08	4,120E -08	3,612E -08
7	1,019E -09	3,233E -09	6,065E -09	1,204E -08	2,144E -08	4,996E +01	4,995E -02
8	1,071E -09	3,510E -09	6,357E -09	1,247E -08	2,309E -08	4,996E -02	4,994E -02
9	1,075E -09	3,278E -09	5,844E -09	1,106E -08	5,000E -02	4,994E -02	4,995E -02
10	3,070E -09	3,619E -09	6,091E -09	1,172E -08	2,283E -08	4,538E -02	4,994E -02
11	1,017E -09	3,669E -09	6,213E -09	1,221E -08	9,343E -06	4,994E -02	4,994E -02
Statistics							
Min	1,017E -09	3,233E -09	5,844E -09	1,106E -08	2,144E -08	4,538E -02	4,994E -02
Max	3,070E -09	3,669E -09	6,357E -09	1,247E -08	5,000E -02	4,996E +01	4,995E -02
Mean	1,450E -09	3,462E -09	6,114E -09	1,190E -08	1,000E -02	1,003E +01	4,995E -02
Sigma	9,059E -10	1,974E -10	1,902E -10	5,419E -10	2,236E -02	2,232E +01	4,000E -06

Test Step	36,85 krad	24 hours	192 hours
Serial #			
1 Ref.	3,756E -08	2,859E -08	3,663E -08
7	4,995E -02	4,996E -02	4,995E -02
8	4,994E -02	4,995E -02	4,994E -02
9	4,993E -02	4,995E -02	4,994E -02
10	4,994E -02	4,992E -02	4,994E -02
11	4,994E -02	4,995E -02	4,994E -02
Statistics			
Min	4,993E -02	4,992E -02	4,994E -02
Max	4,995E -02	4,996E -02	4,995E -02
Mean	4,994E -02	4,995E -02	4,994E -02
Sigma	7,694E -06	1,438E -05	3,285E -06

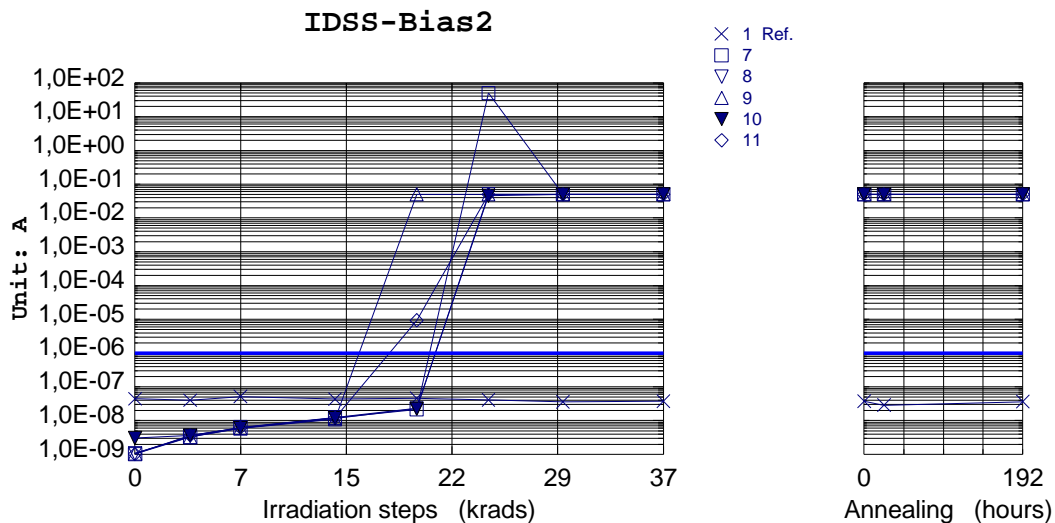

HIREX Engineering	Total Dose Test Report			Réf. : HRX/99.4568 Issue : 01
Part Type :	SP60	Manufacturer :	SGS-THOMSON	

Parameter: Static drain to source on-state resistance: RDSON-Bias1

VGS=10V, ID=27,5A

Unit= Ohm

Spec limit max: 0.022

Spec limits are represented in bold lines on the graphic.

Test Step	Initial	3,85 krad	7,35 krad	13,95 krad	19,65 krad	24,65 krad	29,85 krad
Serial #							
1 Ref.	2,036E -02	2,039E -02	2,021E -02	2,086E -02	2,046E -02	2,054E -02	2,036E -02
2	2,121E -02	2,154E -02	2,129E -02	2,121E -02	2,186E -02	2,150E -02	2,164E -02
3	2,000E -02	2,050E -02	2,014E -02	2,007E -02	2,057E -02	2,029E -02	2,036E -02
4	2,039E -02	2,061E -02	2,275E -02	2,111E -02	2,093E -02	2,086E -02	2,136E -02
5	2,025E -02	2,043E -02	2,046E -02	2,054E -02	2,082E -02	2,061E -02	2,061E -02
6	2,061E -02	2,086E -02	2,079E -02	2,296E -02	2,118E -02	2,096E -02	2,111E -02
Statistics							
Min	2,000E -02	2,043E -02	2,014E -02	2,007E -02	2,057E -02	2,029E -02	2,036E -02
Max	2,121E -02	2,154E -02	2,275E -02	2,296E -02	2,186E -02	2,150E -02	2,164E -02
Mean	2,049E -02	2,079E -02	2,109E -02	2,118E -02	2,107E -02	2,084E -02	2,102E -02
Sigma	4,597E -04	4,495E -04	1,022E -03	1,099E -03	4,902E -04	4,508E -04	5,297E -04

Test Step	36,85 krad	24 hours	192 hours
Serial #			
1 Ref.	2,046E -02	2,057E -02	2,046E -02
2	2,125E -02	2,125E -02	2,114E -02
3	2,007E -02	2,004E -02	2,007E -02
4	2,036E -02	2,050E -02	2,039E -02
5	2,036E -02	2,032E -02	2,122E -02
6	2,068E -02	2,086E -02	2,086E -02
Statistics			
Min	2,007E -02	2,004E -02	2,007E -02
Max	2,125E -02	2,125E -02	2,122E -02
Mean	2,054E -02	2,059E -02	2,074E -02
Sigma	4,499E -04	4,729E -04	4,925E -04

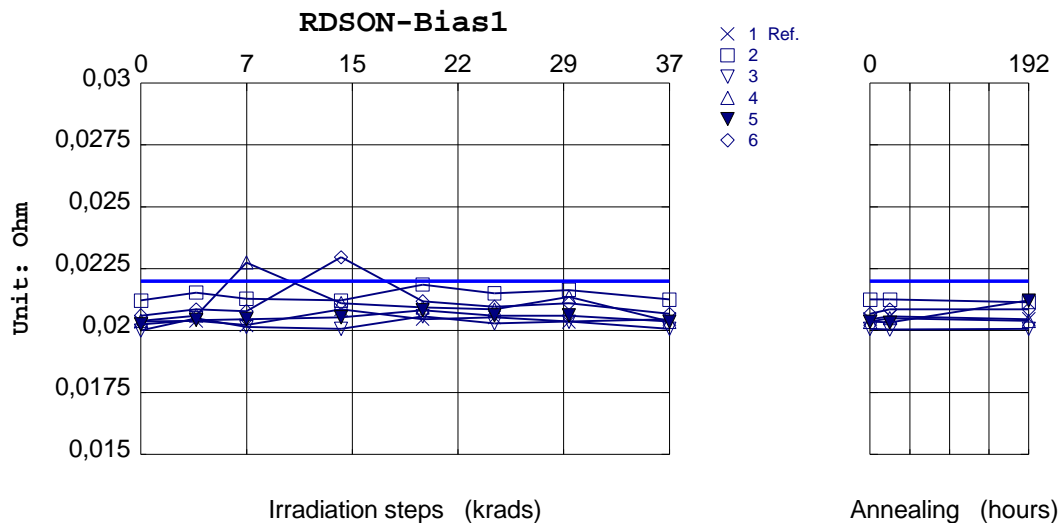

HIREX Engineering	Total Dose Test Report			Réf. : HRX/99.4568 Issue : 01
Part Type :	SP60	Manufacturer :	SGS-THOMSON	

Parameter: Static drain to source on-state resistance: RDSON-Bias2

VGS=10V, ID=27,5A

Unit= Ohm

Spec limit max: 0.022

Spec limits are represented in bold lines on the graphic.

Test Step	Initial	3,85 krad	7,35 krad	13,95 krad	19,65 krad	24,65 krad	29,85 krad
Serial #							
1 Ref.	2,036E -02	2,039E -02	2,021E -02	2,086E -02	2,046E -02	2,054E -02	2,036E -02
7	2,104E -02	2,129E -02	2,132E -02	2,125E -02	2,179E -02	2,157E -02	2,168E -02
8	2,004E -02	2,029E -02	2,025E -02	2,025E -02	2,075E -02	2,054E -02	2,068E -02
9	2,004E -02	2,021E -02	2,018E -02	2,014E -02	2,064E -02	2,043E -02	2,061E -02
10	2,214E -02	2,239E -02	2,221E -02	2,225E -02	2,271E -02	2,257E -02	2,261E -02
11	1,929E -02	1,961E -02	1,946E -02	1,939E -02	1,989E -02	1,971E -02	1,968E -02
Statistics							
Min	1,929E -02	1,961E -02	1,946E -02	1,939E -02	1,989E -02	1,971E -02	1,968E -02
Max	2,214E -02	2,239E -02	2,221E -02	2,225E -02	2,271E -02	2,257E -02	2,261E -02
Mean	2,051E -02	2,076E -02	2,069E -02	2,066E -02	2,116E -02	2,096E -02	2,105E -02
Sigma	1,106E -03	1,095E -03	1,082E -03	1,110E -03	1,101E -03	1,116E -03	1,122E -03

Test Step	36,85 krad	24 hours	192 hours
Serial #			
1 Ref.	2,046E -02	2,057E -02	2,046E -02
7	2,196E -02	2,282E -02	2,200E -02
8	2,050E -02	2,064E -02	2,104E -02
9	2,043E -02	2,061E -02	2,096E -02
10	2,311E -02	2,268E -02	2,304E -02
11	1,971E -02	1,989E -02	2,021E -02
Statistics			
Min	1,971E -02	1,989E -02	2,021E -02
Max	2,311E -02	2,282E -02	2,304E -02
Mean	2,114E -02	2,133E -02	2,145E -02
Sigma	1,369E -03	1,333E -03	1,090E -03

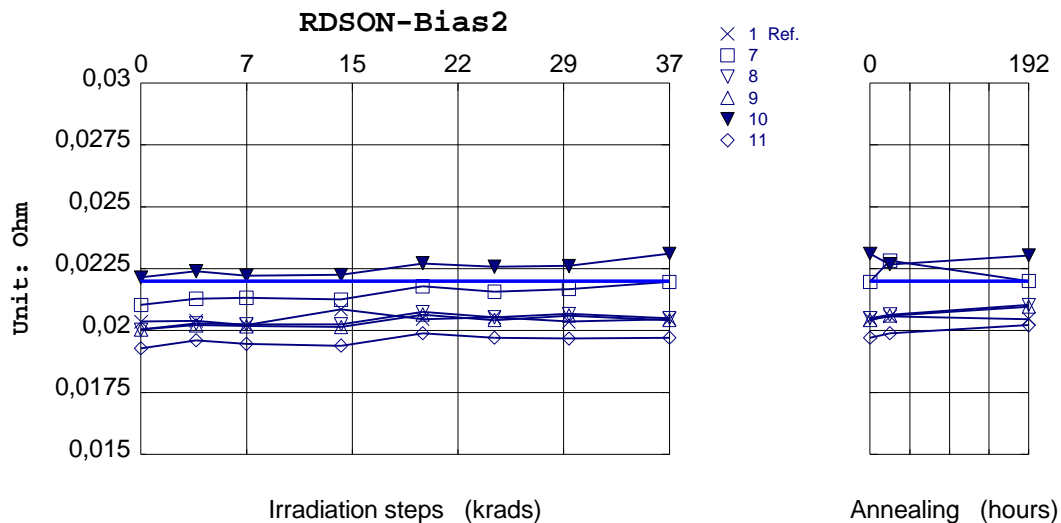

HIREX Engineering	Total Dose Test Report		Réf. : HRX/99.4568 Issue : 01
Part Type :	SP60	Manufacturer :	SGS-THOMSON

8 Conclusion

A total dose radiation verification test has been performed on SP60 N-Channel Power Mosfet from SGS-Thomson up to 36.85 Krad(Si) accumulated dose.

Breakdown voltage is out of specification limit at 19.65 Krad(Si) under Bias 2 conditions, and did not recover for subsequent steps.

IDSS, under Bias 2 conditions, increases significantly for most samples and up to the compliance value of 50mA (for one sample) at a dose level of 19.65 Krad(Si), without further recovery.

Positive gate leakage current remains within specification without significant drift all along the test. Negative gate leakage current does not show significant drift but is out of limits at initial readings.

RDS_{on} (both Bias conditions) does not drift significantly but shows one or two samples marginally outside specification.

HIREX Engineering	Total Dose Test Report		Réf. : HRX/99.4568 Issue : 01
Part Type :	SP60	Manufacturer :	SGS-THOMSON

ANNEX 1 : SP60 DATA SHEET

N - CHANNEL ENHANCEMENT MODE " SINGLE FEATURE SIZE™ " POWER MOSFET

TYPE	V _{DSS}	R _{DS(on)}	I _D
STP55NE06	60 V	< 0.022 Ω	55 A
STP55NE06FP	60 V	< 0.022 Ω	30 A

- TYPICAL R_{DS(on)} = 0.019 Ω
- EXCEPTIONAL dv/dt CAPABILITY
- 100% AVALANCHE TESTED
- LOW GATE CHARGE 100 °C
- HIGH dv/dt CAPABILITY
- APPLICATION ORIENTED CHARACTERIZATION

DESCRIPTION

This Power Mosfet is the latest development of SGS-THOMSON unique "Single Feature Size" strip-based process. The resulting transistor shows extremely high packing density for low on-resistance, rugged avalanche characteristics and less critical alignment steps therefore a remarkable manufacturing reproducibility.

APPLICATIONS

- DC MOTOR CONTROL
- DC-DC & DC-AC CONVERTERS
- SYNCHRONOUS RECTIFICATION

ABSOLUTE MAXIMUM RATINGS

Symbol	Parameter	Value		Unit
		STP55NE06	STP55NE06FP	
V _{DS}	Drain-source Voltage (V _{GS} = 0)	60		V
V _{DGR}	Drain- gate Voltage (R _{GS} = 20 kΩ)	60		V
V _{GS}	Gate-source Voltage	± 20		V
I _D	Drain Current (continuous) at T _c = 25 °C	55	30	A
I _D	Drain Current (continuous) at T _c = 100 °C	39	21	A
I _{DM} (•)	Drain Current (pulsed)	220	220	A
P _{tot}	Total Dissipation at T _c = 25 °C	130	35	W
	Derating Factor	0.96	0.27	W/°C
V _{ISO}	Insulation Withstand Voltage (DC)	—	2000	V
dv/dt	Peak Diode Recovery voltage slope	7		V/ns
T _{stg}	Storage Temperature	-65 to 175		°C
T _j	Max. Operating Junction Temperature	175		°C

(•) Pulse width limited by safe operating area

(1) I_{SD} ≤ 55 A, di/dt ≤ 300 A/μs, V_{DD} ≤ V_{(BR)DSS}, T_j ≤ T_{JMAX}

January 1998

1/9

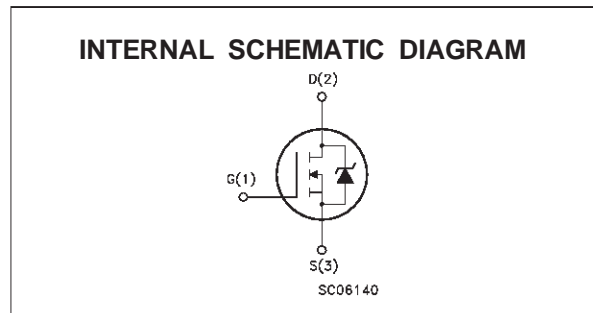
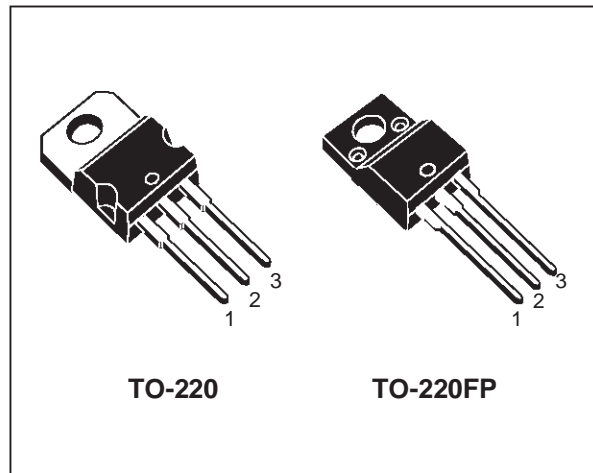

STP55NE06/FP

THERMAL DATA

		TO-220	TO-220FP		
R _{thj-case}	Thermal Resistance Junction-case	Max	1.15	4.28	°C/W
R _{thj-amb}	Thermal Resistance Junction-ambient	Max	62.5		°C/W
R _{thc-sink}	Thermal Resistance Case-sink	Typ	0.5		°C/W
T _l	Maximum Lead Temperature For Soldering Purpose		300		°C

AVALANCHE CHARACTERISTICS

Symbol	Parameter	Max Value	Unit
I _{AR}	Avalanche Current, Repetitive or Not-Repetitive (pulse width limited by T _j max, δ < 1%)	55	A
E _{AS}	Single Pulse Avalanche Energy (starting T _j = 25 °C, I _D = I _{AR} , V _{DD} = 25 V)	200	mJ

ELECTRICAL CHARACTERISTICS (T_{case} = 25 °C unless otherwise specified)

OFF

Symbol	Parameter	Test Conditions	Min.	Typ.	Max.	Unit
V _{(BR)DSS}	Drain-source Breakdown Voltage	I _D = 250 μA V _{GS} = 0	60			V
I _{DSS}	Zero Gate Voltage Drain Current (V _{GS} = 0)	V _{DS} = Max Rating V _{DS} = Max Rating T _c = 125 °C			1 10	μA μA
I _{GSS}	Gate-body Leakage Current (V _{DS} = 0)	V _{GS} = ± 20 V			± 100	nA

ON (*)

Symbol	Parameter	Test Conditions	Min.	Typ.	Max.	Unit
V _{GS(th)}	Gate Threshold Voltage	V _{DS} = V _{GS} I _D = 250 μA	2	3	4	V
R _{DS(on)}	Static Drain-source On Resistance	V _{GS} = 10V I _D = 27.5 A		0.019	0.022	Ω
I _{D(on)}	On State Drain Current	V _{DS} > I _{D(on)} × R _{DS(on)max} V _{GS} = 10 V	55			A

DYNAMIC

Symbol	Parameter	Test Conditions	Min.	Typ.	Max.	Unit
g _{fs} (*)	Forward Transconductance	V _{DS} > I _{D(on)} × R _{DS(on)max} I _D = 27.5 A	25	35		S
C _{iss}	Input Capacitance	V _{DS} = 25 V f = 1 MHz V _{GS} = 0		3050	4000	pF
C _{oss}	Output Capacitance			380	500	pF
C _{rss}	Reverse Transfer Capacitance			100	130	pF

ELECTRICAL CHARACTERISTICS (continued)

SWITCHING ON

Symbol	Parameter	Test Conditions	Min.	Typ.	Max.	Unit
$t_{d(on)}$	Turn-on Time	$V_{DD} = 30\text{ V}$ $I_D = 27.5\text{ A}$		30	40	ns
t_r	Rise Time	$R_G = 4.7\ \Omega$ $V_{GS} = 10\text{ V}$ (see test circuit, figure 3)		120	160	ns
Q_g	Total Gate Charge	$V_{DD} = 48\text{ V}$ $I_D = 55\text{ A}$ $V_{GS} = 10\text{ V}$		80	105	nC
Q_{gs}	Gate-Source Charge			13		nC
Q_{gd}	Gate-Drain Charge			25		nC

SWITCHING OFF

Symbol	Parameter	Test Conditions	Min.	Typ.	Max.	Unit
$t_{r(Voff)}$	Off-voltage Rise Time	$V_{DD} = 48\text{ V}$ $I_D = 55\text{ A}$		20	30	ns
t_f	Fall Time	$R_G = 4.7\ \Omega$ $V_{GS} = 10\text{ V}$ (see test circuit, figure 5)		50	70	ns
t_c	Cross-over Time			75	100	ns

SOURCE DRAIN DIODE

Symbol	Parameter	Test Conditions	Min.	Typ.	Max.	Unit
I_{SD}	Source-drain Current				55	A
$I_{SDM}(\bullet)$	Source-drain Current (pulsed)				220	A
$V_{SD} (*)$	Forward On Voltage	$I_{SD} = 60\text{ A}$ $V_{GS} = 0$			1.5	V
t_{rr}	Reverse Recovery Time	$I_{SD} = 55\text{ A}$ $di/dt = 100\text{ A}/\mu\text{s}$ $V_{DD} = 30\text{ V}$ $T_j = 150\text{ }^\circ\text{C}$ (see test circuit, figure 5)		110		ns
Q_{rr}	Reverse Recovery Charge			430		μC
I_{RRM}	Reverse Recovery Current			7.5		A

(*) Pulsed: Pulse duration = 300 μs , duty cycle 1.5 %

(\bullet) Pulse width limited by safe operating area

Safe Operating Area for TO-220

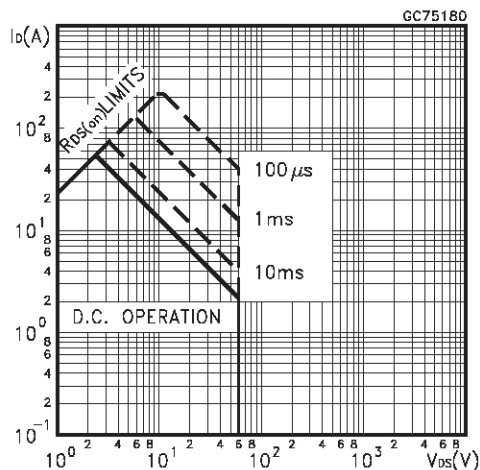

Safe Operating Area for TO-220FP

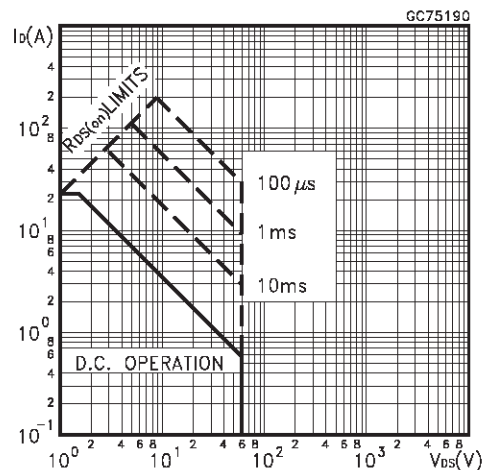

Thermal Impedance for TO-220

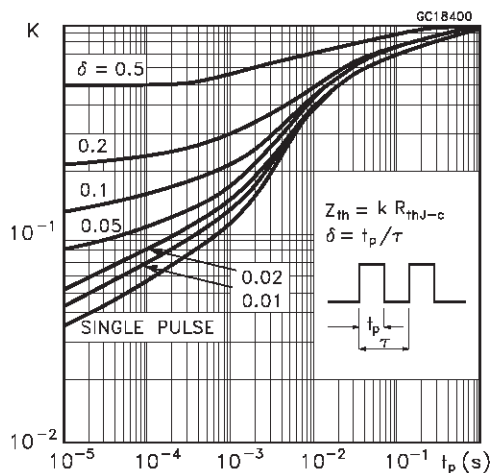

Thermal Impedance for TO-220FP

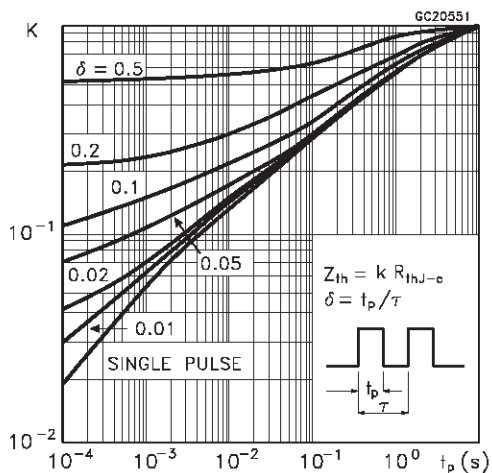

Output Characteristics

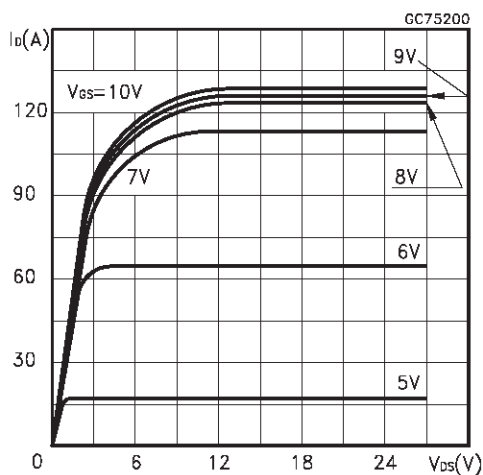

Transfer Characteristics

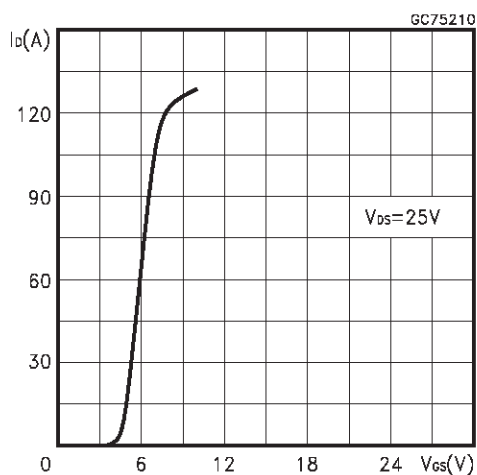

Transconductance

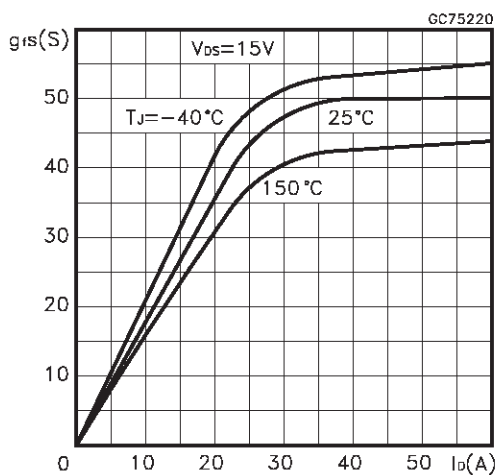

Static Drain-source On Resistance

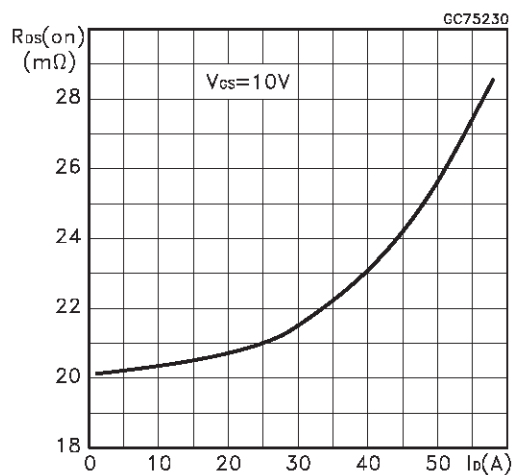

Gate Charge vs Gate-source Voltage

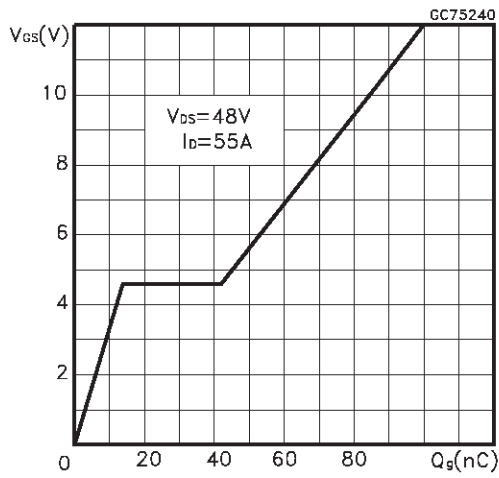

Capacitance Variations

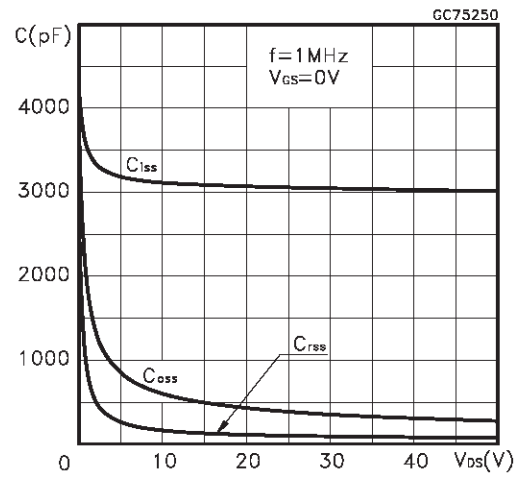

Normalized Gate Threshold Voltage vs Temperature

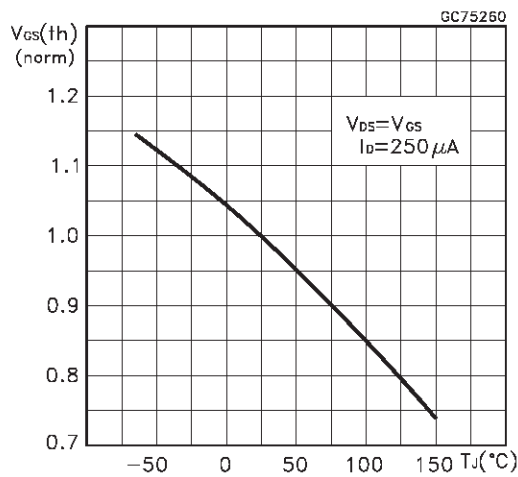

Normalized On Resistance vs Temperature

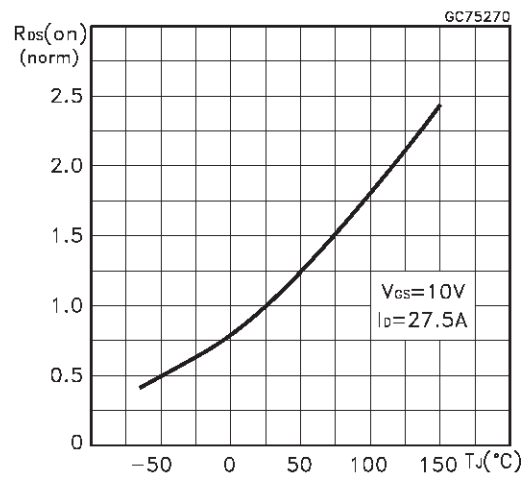

Source-drain Diode Forward Characteristics

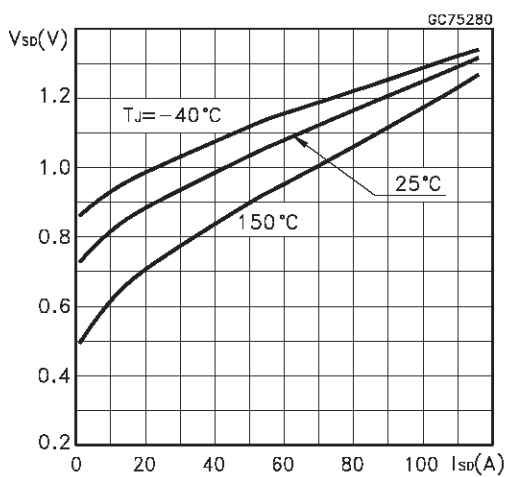

Fig. 1: Unclamped Inductive Load Test Circuit

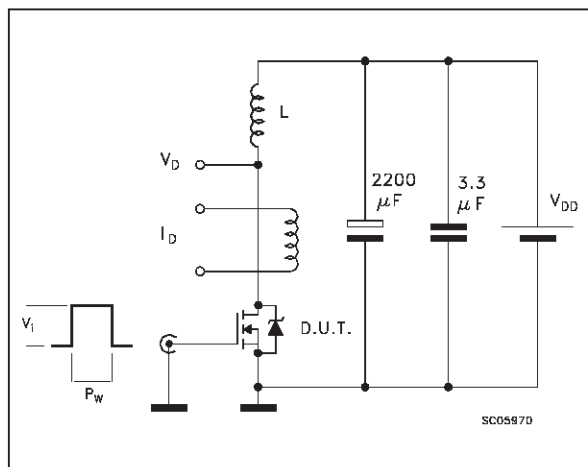

Fig. 2: Unclamped Inductive Waveform

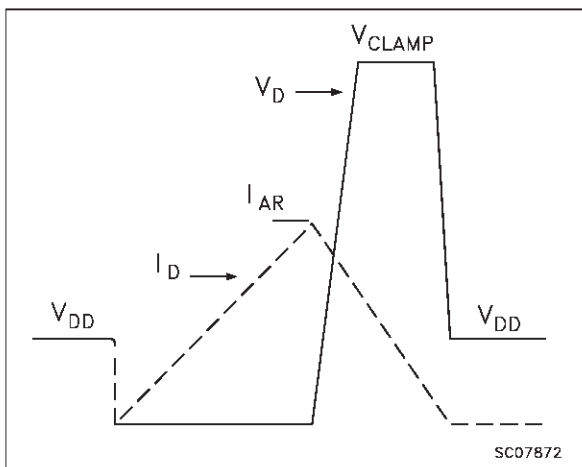

Fig. 3: Switching Times Test Circuits For Resistive Load

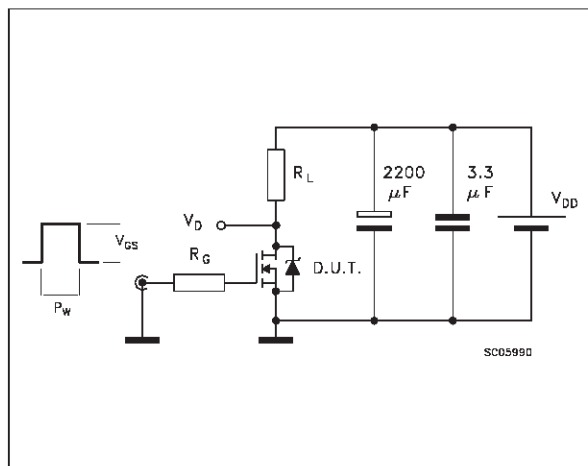

Fig. 4: Gate Charge test Circuit

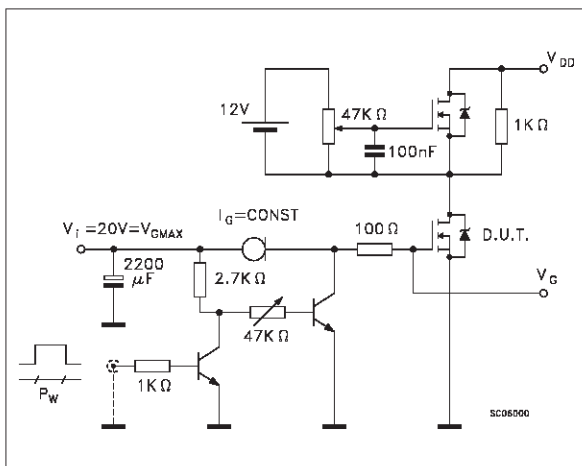
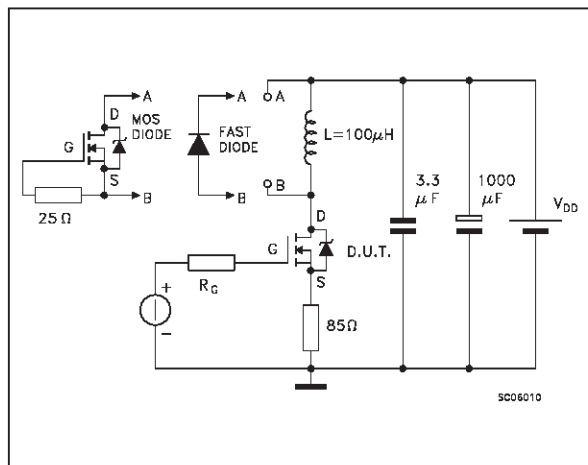
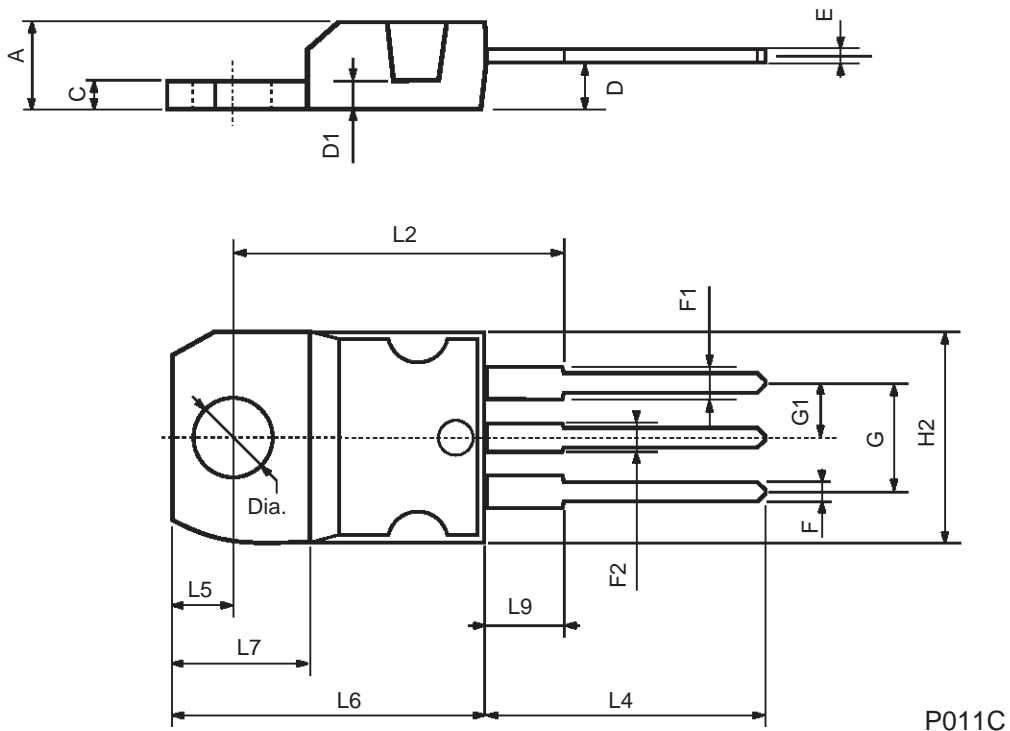

Fig. 5: Test Circuit For Inductive Load Switching And Diode Recovery Times



TO-220 MECHANICAL DATA

DIM.	mm			inch		
	MIN.	TYP.	MAX.	MIN.	TYP.	MAX.
A	4.40		4.60	0.173		0.181
C	1.23		1.32	0.048		0.051
D	2.40		2.72	0.094		0.107
D1		1.27			0.050	
E	0.49		0.70	0.019		0.027
F	0.61		0.88	0.024		0.034
F1	1.14		1.70	0.044		0.067
F2	1.14		1.70	0.044		0.067
G	4.95		5.15	0.194		0.203
G1	2.4		2.7	0.094		0.106
H2	10.0		10.40	0.393		0.409
L2		16.4			0.645	
L4	13.0		14.0	0.511		0.551
L5	2.65		2.95	0.104		0.116
L6	15.25		15.75	0.600		0.620
L7	6.2		6.6	0.244		0.260
L9	3.5		3.93	0.137		0.154
DIA.	3.75		3.85	0.147		0.151



TO-220FP MECHANICAL DATA

DIM.	mm			inch		
	MIN.	TYP.	MAX.	MIN.	TYP.	MAX.
A	4.4		4.6	0.173		0.181
B	2.5		2.7	0.098		0.106
D	2.5		2.75	0.098		0.108
E	0.45		0.7	0.017		0.027
F	0.75		1	0.030		0.039
F1	1.15		1.7	0.045		0.067
F2	1.15		1.7	0.045		0.067
G	4.95		5.2	0.195		0.204
G1	2.4		2.7	0.094		0.106
H	10		10.4	0.393		0.409
L2		16			0.630	
L3	28.6		30.6	1.126		1.204
L4	9.8		10.6	0.385		0.417
L6	15.9		16.4	0.626		0.645
L7	9		9.3	0.354		0.366
Ø	3		3.2	0.118		0.126

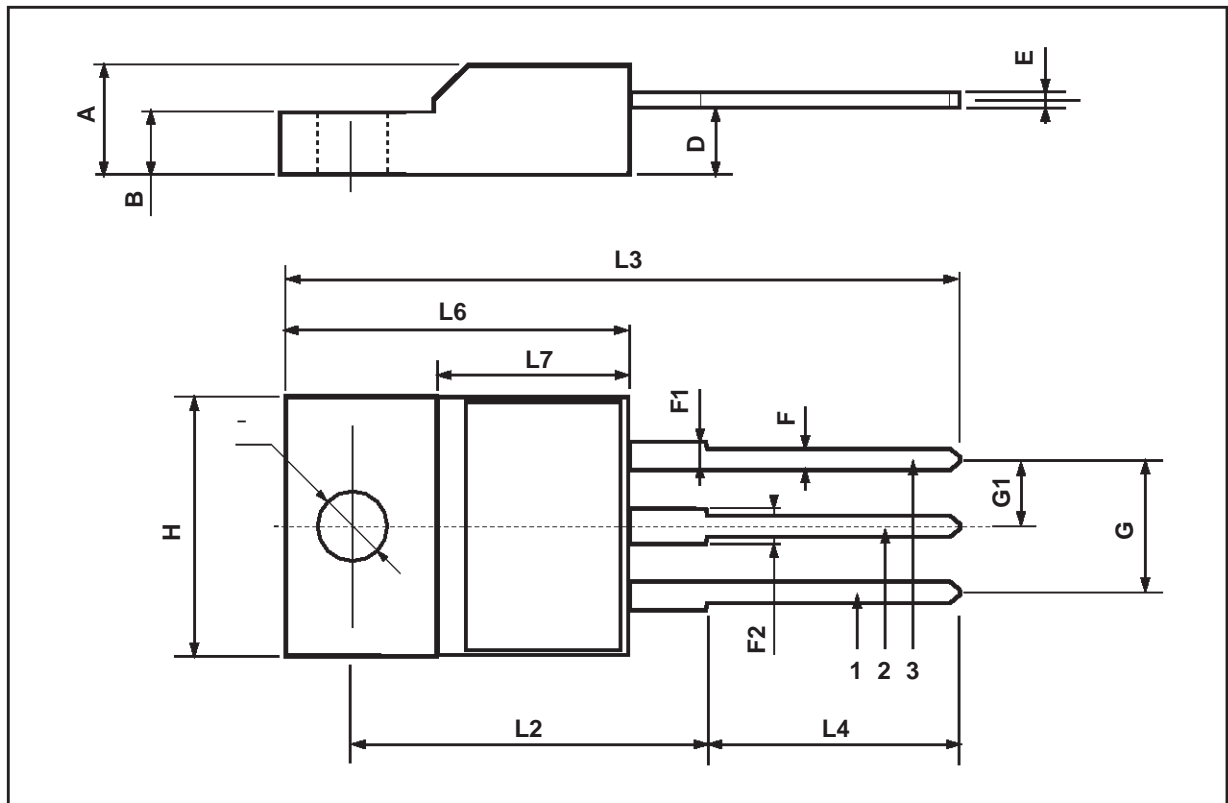

Information furnished is believed to be accurate and reliable. However, SGS-THOMSON Microelectronics assumes no responsibility for the consequences of use of such information nor for any infringement of patents or other rights of third parties which may result from its use. No license is granted by implication or otherwise under any patent or patent rights of SGS-THOMSON Microelectronics. Specifications mentioned in this publication are subject to change without notice. This publication supersedes and replaces all information previously supplied. SGS-THOMSON Microelectronics products are not authorized for use as critical components in life support devices or systems without express written approval of SGS-THOMSON Microelectronics.

© 1997 SGS-THOMSON Microelectronics - Printed in Italy - All Rights Reserved

SGS-THOMSON Microelectronics GROUP OF COMPANIES

Australia - Brazil - Canada - China - France - Germany - Italy - Japan - Korea - Malaysia - Malta - Morocco - The Netherlands -
Singapore - Spain - Sweden - Switzerland - Taiwan - Thailand - United Kingdom - U.S.A

...