



**CONNECTOR SAVERS, ELECTRICAL, RECTANGULAR,
MICROMINIATURE, NON-REMOVABLE GAUGE 26
CONTACTS**

BASED ON TYPE 8MCG

Draft ESCC Detail Specification No. 3401/088

Issue 1	May 2018
---------	----------



LEGAL DISCLAIMER AND COPYRIGHT

European Space Agency, Copyright © 2018. All rights reserved.

The European Space Agency disclaims any liability or responsibility, to any person or entity, with respect to any loss or damage caused, or alleged to be caused, directly or indirectly by the use and application of this ESCC publication.

This publication, without the prior permission of the European Space Agency and provided that it is not used for a commercial purpose, may be:

- copied in whole, in any medium, without alteration or modification.
- copied in part, in any medium, provided that the ESCC document identification, comprising the ESCC symbol, document number and document issue, is removed.

DOCUMENTATION CHANGE NOTICE

(Refer to <https://escies.org> for ESCC DCR content)

DCR No.	CHANGE DESCRIPTION

TABLE OF CONTENTS

1	GENERAL	6
1.1	SCOPE	6
1.2	RANGE OF COMPONENTS	6
1.3	MAXIMUM RATINGS	6
1.4	PARAMETER DERATING INFORMATION	6
1.5	PHYSICAL DIMENSIONS	6
1.6	CONTACT ARRANGEMENTS	6
2	APPLICABLE DOCUMENTS	6
3	TERMS, DEFINITIONS, ABBREVIATIONS, SYMBOLS AND UNITS	7
4	REQUIREMENTS	12
4.1	GENERAL	12
4.2	DEVIATIONS FROM GENERIC SPECIFICATION	12
4.2.1	Deviations from Special In-Process Controls	12
4.2.2	Deviations from Final Production Tests (Chart II)	12
4.2.3	Deviations from Burn-in and Electrical Measurements (Chart III)	12
4.2.4	Deviations from Qualification Tests (Chart IV)	13
4.2.5	Deviations from Lot Acceptance Tests (Chart V)	13
4.3	MECHANICAL REQUIREMENTS	13
4.3.1	Dimension Check	13
4.3.2	Weight	13
4.3.3	Contact Capability	13
4.3.4	Contact Retention (in Insert)	13
4.3.5	Mating and Unmating Forces	13
4.3.6	Insert Retention (in Shell)	13
4.3.7	Jackscrew Retention	13
4.3.8	Contact Insertion and Withdrawal Forces	14
4.3.9	Engagement and Separation Forces	14
4.3.10	Oversize Pin Exclusion	14
4.3.11	Probe Damage	14
4.3.12	Solderability	14
4.4	MATERIALS AND FINISHES	14
4.4.1	Shells	14
4.4.2	Inserts	15
4.4.3	Protective Skirt	15
4.4.4	Contacts	15

4.4.5	Accessories	15
4.4.6	Magnetism Level	15
4.5	MARKING	15
4.5.1	General	15
4.5.2	Contact Position	15
4.5.3	The ESCC Component Number	15
4.5.4	Characteristics	15
4.5.4.1	Shell Size and Contact Arrangement	16
4.5.4.2	Type of Contact	16
4.5.4.3	Magnetism Level	16
4.5.5	Traceability Information	16
4.6	ELECTRICAL MEASUREMENTS	16
4.6.1	Electrical Measurements at Room Temperature	16
4.6.2	Electrical Measurements at High and Low Temperatures (Table 3)	16
4.6.3	Circuit for Electrical Measurements (Figure 4)	16
4.7	BURN-IN AND ELECTRICAL MEASUREMENTS (TABLES 4 AND 5)	16
4.8	ENVIRONMENTAL AND ENDURANCE TESTS (CHARTS IV AND V OF ESCC GENERIC SPECIFICATION NO. 3401)	17
4.8.1	Measurements and Inspections on Completion of Environmental Tests	17
4.8.2	Measurements and Inspections at Intermediate Points during Endurance Tests	18
4.8.3	Measurements and Inspections on Completion of Endurance Tests	18
4.8.4	Conditions for Operating Life Test (Part of Endurance Testing)	18
4.8.5	Electrical Circuit for Operating Life Test (Figure 5)	18
4.8.6	Conditions for High Temperature Storage Test (Part of Endurance Testing)	18

1 GENERAL

1.1 SCOPE

This specification details the ratings, physical and electrical characteristics, test and inspection data for Connector Savers, Electrical, Rectangular, Microminiature with Non-Removable Gauge 26 Contacts, Based on Type 8MCG.

The following ESCC Specifications, the requirements of which are supplemented herein, are associated with this specification:

- ESCC Generic Specification No. [3401](#), Connectors, Electrical, Non-Filtered, Circular and Rectangular.
- ESCC Detail Specification No. [3401/081](#), Connectors, Electrical, Rectangular, Microminiature, Non-removable Gauge 26 PCB Pin Contacts, Based on Type 8MCG.
- ESCC Detail Specification No. [3401/082](#), Connectors, Electrical, Rectangular, Microminiature, Removable Gauge 26 Crimp Contacts, Based on Type 8MCG.
- ESCC Detail Specification No. [3401/084](#), Accessories for Connectors, Microminiature, 3401/081, 3401/082 and Connector Savers 3401/088.

1.2 RANGE OF COMPONENTS

The different sizes of connector savers specified herein, together with their mechanical characteristics, are given in Table 1(a).

1.3 MAXIMUM RATINGS

The maximum ratings, which shall not be exceeded at any time during use or storage, applicable to the connector savers specified herein, are scheduled in Table 1(b).

1.4 PARAMETER DERATING INFORMATION

The applicable derating information for the connector savers specified herein is shown in Figure 1.

1.5 PHYSICAL DIMENSIONS

The physical dimensions of the connector savers specified herein is shown in Figure 2.

1.6 CONTACT ARRANGEMENTS

The contact arrangements are shown in Figure 3.

2 APPLICABLE DOCUMENTS

The following documents form part of this specification and shall be read in conjunction with it:

- (a) ESCC Generic Specification No. [3401](#), Connectors, Electrical, Non-Filtered, Circular and Rectangular.
- (b) ESCC Detail Specification No. [3401/084](#), Accessories for Connectors, Microminiature, 3401/081, 3401/082 and Connector Savers 3401/088.

3 TERMS, DEFINITIONS, ABBREVIATIONS, SYMBOLS AND UNITS

For the purpose of this specification, the terms, definitions, abbreviations, symbols and units specified in ESCC Basic Specification No. 21300 shall apply.

TABLE 1(a) – COMPONENT TYPE VARIANTS AND RANGE OF COMPONENTS

Shell Size (Note 1)	Max. Weight (g)		Mating Force (N max)	Unmating Force	
	Variant 01 (Note 2)	Variant 02 (Note 2)		N min	N max
A	3.17	3.92	11.9	0.95	11.9
B	4.24	5.19	18.7	1.5	18.7
C	4.97	6.27	22.1	1.8	22.1
D	5.88	7.18	28.9	2.35	28.9
E	6.98	8.39	35.7	2.9	35.7
F	7.88	9.28	42.5	3.5	42.5
G	9.18	10.68	56.1	4.6	56.1
H	13.22	15.13	86.7	7.1	86.7
J	24.35	27.25	178.8	14.5	178.8

NOTES:

1. See Figure 2(a).
2. Refer to Para. 4.4.1 for definition of the Type Variants.

TABLE 1(b) - MAXIMUM RATINGS

No.	Characteristics	Symbol	Maximum Rating	Unit
1	Working Voltage (Sea Level)	U_R	150	V _{rms}
2	Rated Current	I_R	2.5	A
3	Operating Temperature Range	T_{op}	-55 to +125	°C
4	Storage Temperature Range	T_{stg}	-65 to +125	°C

FIGURE 1 - PARAMETER DERATING INFORMATIONWorking Voltage versus Altitude

FIGURE 2 - PHYSICAL DIMENSIONS

FIGURE 2(a) - CONNECTOR SAVER

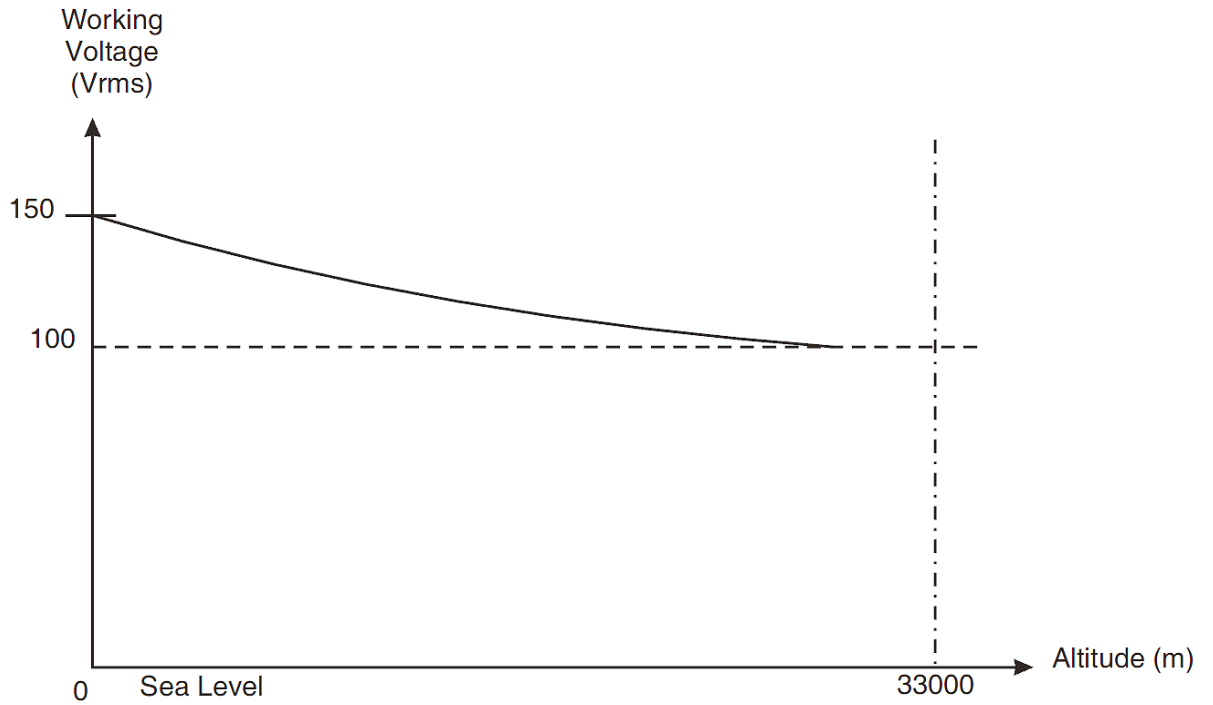
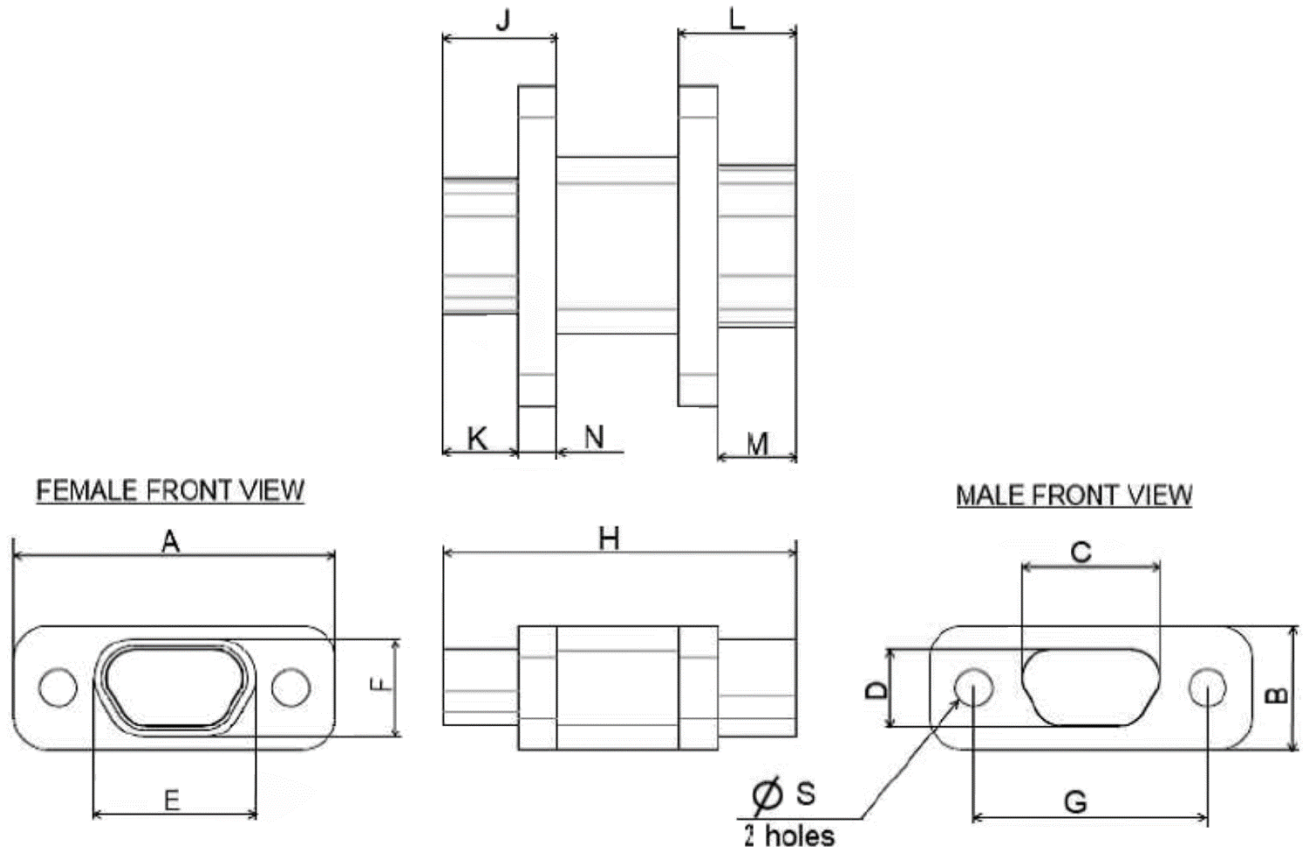

Shell Size	A	B	C	D	E	F	G		H	J	K	L	M	N		ØS (Note 2)	
	Max	Max	Max	Max	Max	Max	Min	Max	Max	Max	Max	Max	Max	Min	Max	Min	Max
A	19.94	7.82	8.48	4.69	10.16	6.38	14.22	14.48	21.95	7.21	4.72	7.54	5.05	2.2	2.5	2.2	2.4
B	23.75	7.82	12.29	4.69	13.97	6.38	18.03	18.29	21.95	7.21	4.72	7.54	5.05	2.2	2.5	2.2	2.4
C	27.56	7.82	16.1	4.69	17.78	6.38	21.84	22.1	21.95	7.21	4.72	7.54	5.05	2.2	2.5	2.2	2.4
D	30.1	7.82	18.64	4.69	20.32	6.38	24.38	24.64	21.95	7.21	4.72	7.54	5.05	2.2	2.5	2.2	2.4
E	33.91	7.82	22.45	4.69	24.13	6.38	28.19	28.45	21.95	7.21	4.72	7.54	5.05	2.2	2.5	2.2	2.4
F	37.72	7.82	26.26	4.69	27.94	6.38	32	32.26	21.95	7.21	4.72	7.54	5.05	2.2	2.5	2.2	2.4
G	36.45	8.92	24.99	5.78	26.67	7.47	30.73	30.99	21.95	7.21	4.72	7.54	5.05	2.2	2.5	2.2	2.4
H	48.55	8.92	36.85	5.78	38.65	7.47	43.23	43.49	21.95	7.21	4.72	7.54	5.05	2.2	2.5	2.2	2.4
J	62.75	12.5	45.1	9.25	46.8	10.94	54.72	54.98	21.95	7.21	4.72	7.54	5.05	2.2	2.5	3.7	3.8

NOTES:

1. All dimensions are in millimetres.
2. For shell size H only, the mounting holes may be as shown below. Such holes shall be centred as per the circular holes shown above.

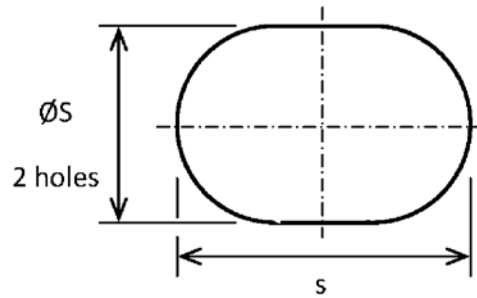

2 holes

Dimension s shall be 2.76mm minimum and 2.99mm maximum.

- Only the underlined dimensions shall be checked during procurement.

FIGURE 2(b) - CONTACT ARRANGEMENTS

FRONT VIEW MALE INSERT – USE MIRROR VIEW FOR FEMALE INSERT

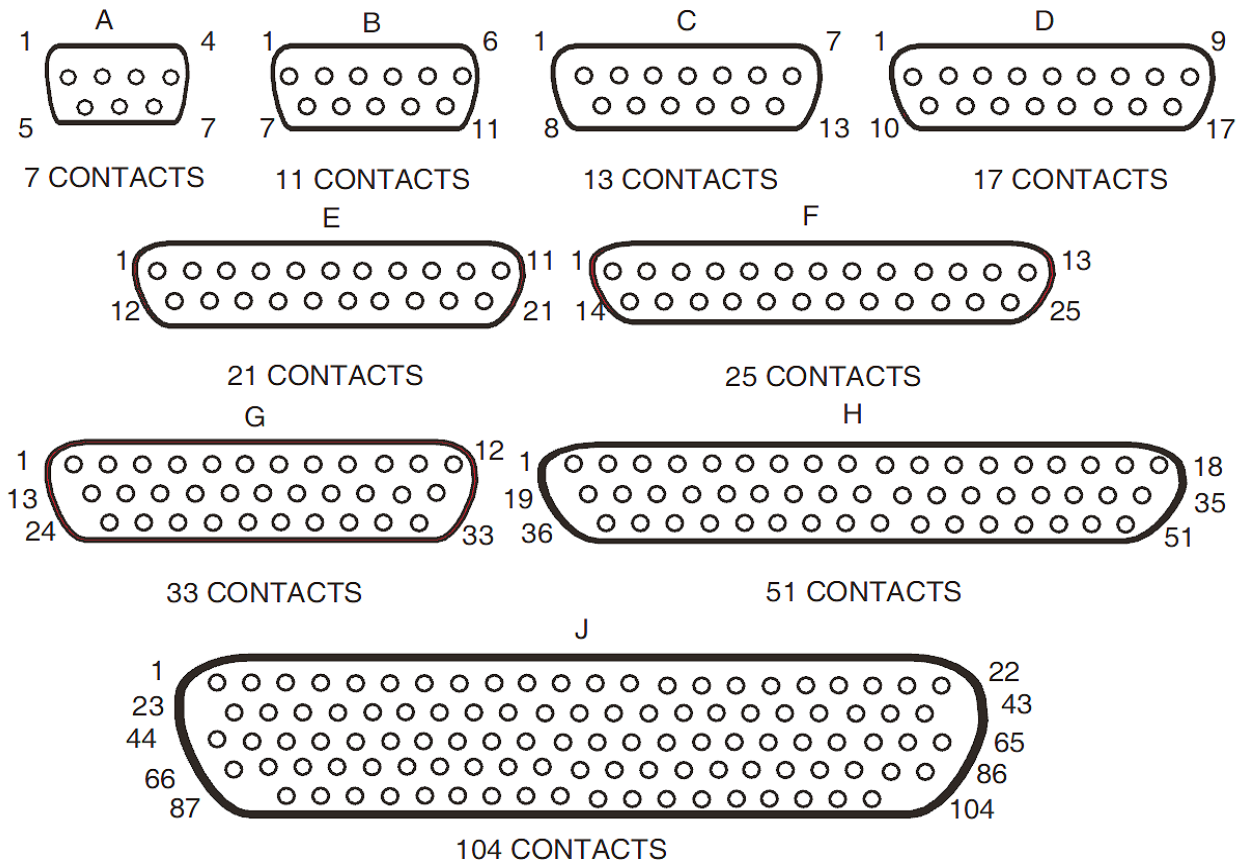

NOTES:

- Only the outside contact cavities on each row are identified in the drawing, the remainder follow sequentially. Contact numbers are shown outside the insert for readability.

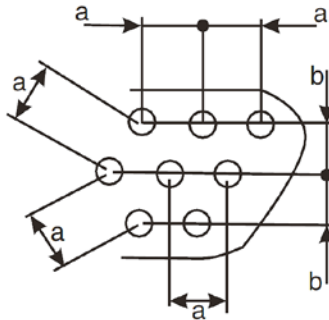

2. a = Distance between contact centres: 2mm typical.
b = Distance between rows: 1.732mm typical.

FIGURE 2(c) – MATING DIMENSIONS AND CONTACT POSITION

Mounting Condition

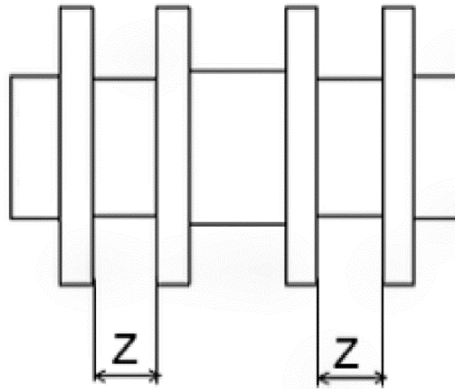

Plug Male Contact

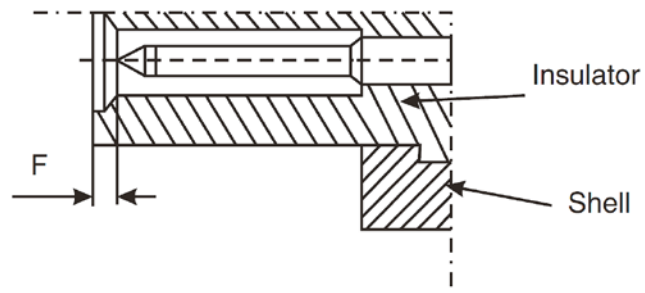

Receptacle Female Contact

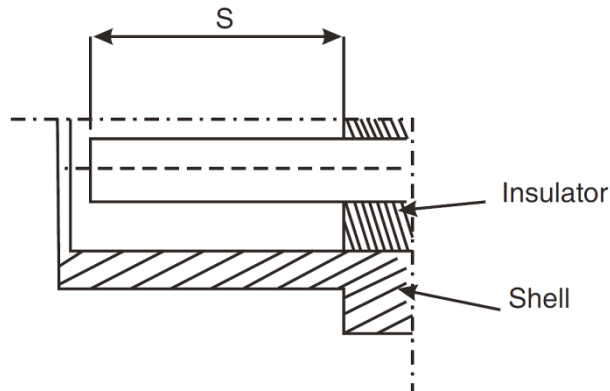

F		S		Z
Min	Max	Min	Max	Max
0.22	0.72	4.15	4.65	5.21

NOTES:

1. All dimensions are in millimetres.

4 REQUIREMENTS

4.1 GENERAL

The complete requirements for procurement of the connectors specified herein are stated in this specification and ESCC Generic Specification No. 3401. Deviations from the Generic Specification, applicable to this specification only, are listed in Para. 4.2.

Deviations from the applicable Generic Specification and this Detail Specification, formally agreed with specific Manufacturers on the basis that the alternative requirements are equivalent to the ESCC requirements and do not affect the components' reliability, are listed in the appendices attached to this specification.

4.2 DEVIATIONS FROM GENERIC SPECIFICATION

4.2.1 Deviations from Special In-Process Controls

None.

4.2.2 Deviations from Final Production Tests (Chart II)

- (a) Para. 9.1.1.4, Mated Shell Conductivity: Not applicable.
- (b) Para. 9.9, Seal Test: Not applicable.

4.2.3 Deviations from Burn-in and Electrical Measurements (Chart III)

Chart III is not applicable.

- 4.2.4 Deviations from Qualification Tests (Chart IV)
- (a) Para. 9.1.1.4, Mated Shell Conductivity: Not applicable.
 - (b) Para. 9.9, Seal Test: Not applicable.
 - (c) Para. 9.15, Joint Strength: Not applicable.
 - (d) Para. 9.24, Jackscrew Retention: Not applicable.
 - (e) Para. 9.27, Maintenance Aging: Not applicable.
 - (f) Para. 9.31, Solderability: Not applicable.

- 4.2.5 Deviations from Lot Acceptance Tests (Chart V)
- (a) Para. 9.1.1.4, Mated Shell Conductivity: Not applicable.
 - (b) Para. 9.9, Seal Test: Not applicable.
 - (c) Para. 9.15, Joint Strength: Not applicable.
 - (d) Para. 9.24, Jackscrew Retention: Not applicable.
 - (e) Para. 9.27, Maintenance Aging: Not applicable.
 - (f) Para. 9.31, Solderability: Not applicable.

4.3 MECHANICAL REQUIREMENTS

4.3.1 Dimension Check

The dimensions of the connector savers specified herein shall be verified in accordance with the requirements set out in Para. 9.6 of ESCC Generic Specification No. 3401 and shall conform to those shown in Figure 2 of this specification.

4.3.2 Weight

The maximum weight of the connector savers specified herein shall be as specified in Table 1(a).

4.3.3 Contact Capability

For the purpose of this test, the pick-up and drop weights shall be as follows.

Measurements		Pick-Up Weight	Drop Weight
Weight (g)		14.3	81.5
Test Pin diameter (mm)	Minimum	0.495	0.519
	Maximum	0.497	0.521
Insertion depth (mm)		3	3

4.3.4 Contact Retention (in Insert)

The contact retention force within the insert shall be 15N.

4.3.5 Mating and Unmating Forces

The forces applied for the mating and unmating of the connector savers shall conform to the values specified in Table 1(a).

4.3.6 Insert Retention (in Shell)

Connector saver inserts shall withstand a pressure of 34.4N/cm² without being dislodged from the shell.

4.3.7 Jackscrew Retention

Not applicable.

4.3.8 Contact Insertion and Withdrawal Forces

Not applicable.

4.3.9 Engagement and Separation Forces

The engagement and separation forces of the female contacts shall be tested and shall not exceed the values of the table hereunder. Details of the test pin are specified in Figure 3.

Measurements	ØA (mm)		Engagement Force Max. (N)	Separation Force Min. (N)
	Min.	Max.		
Max. Diameter Test Pin	0.519	0.521	1.667	-
Min. Diameter Test Pin	0.495	0.497	-	0.14

4.3.10 Oversize Pin Exclusion

The diameter of the test pin and the force applied to it shall be as follows.

Test Pin Dia. (mm)		Force (N) Max.
Min.	Max.	
0.765	0.77	0.8

4.3.11 Probe Damage

The probe diameter and the moment at the end of the probe shall be as follows.

Probe Dia. (mm)		Moment (N.cm)
Min.	Max.	
0.495	0.521	0.9

4.3.12 Solderability

Not applicable.

4.4 MATERIALS AND FINISHES

The materials and finishes shall be as specified herein. Where a definite material is not specified, a material which will enable the components specified herein to meet the performance requirements of this specification shall be used. Acceptance or approval of any constituent material does not guarantee acceptance of the finished product.

4.4.1 Shells

Variant 01

Shells shall be made of glass-fibre reinforced thermoplastic. The plating shall be 1.27µm minimum of gold over 5µm minimum of electroless nickel or copper.

Variant 02

Shells shall be made of aluminium alloy. The plating shall be 1.27µm minimum of gold over 20µm minimum of electroless nickel.

4.4.2 Inserts

Inserts shall be made of thermoplastic material.

4.4.3 Protective Skirt

Protective skirt shall be made of silicone elastomer.

4.4.4 Contacts

The contact body and the spring element shall be made of copper alloy with an underplate of 1µm minimum of nickel or copper, gold plated with 1.27µm minimum of gold.

4.4.5 Accessories

As specified in ESCC Specification No. [3401/084](#).

4.4.6 Magnetism Level

The allowable value of magnetism shall not exceed that specified for the relevant level (see Para. 4.5.4.3). Only magnetism levels NMC and NMD are verified.

4.5 MARKING

4.5.1 General

The marking of components delivered to this specification shall be in accordance with the requirements of ESCC Basic Specification No. [21700](#) and the following paragraphs.

Each component shall be marked in respect of:

- (a) Contact Position.
- (b) The ESCC Component Number.
- (c) Characteristics.
- (d) Traceability Information.

4.5.2 Contact Position

The contact positions shall be marked on the insert in accordance with Figure 2(b).

4.5.3 The ESCC Component Number

Each component shall bear the ESCC Component Number which shall be constituted and marked as follows:

Example: 340108801B

- Detail Specification Number: 3401088
- Type Variant (See Table 1(a)): 01
- Testing Level: B

4.5.4 Characteristics

The characteristics to be marked in the following order of precedence are:

- (a) Shell Size.
- (b) Contact Arrangement.
- (c) Type of Contact.
- (d) Magnetism Level (only applicable to Variant 01).

The information shall be constituted and marked as follows (example): C13PSNMB

- Shell size: C
- Contact Arrangement: 13
- Type of Contact: PS
- Magnetism Level (200 gamma): NMB

4.5.4.1 *Shell Size and Contact Arrangement*

Shell size shall be as designated in Table 1(a) and Figure 2(a). The shell size code also defines the contact arrangement. The layouts of the available contact arrangements are shown in Figure 2(b).

4.5.4.2 *Type of Contact*

Contact type code PS indicates a Male/Female contact type.

4.5.4.3 *Magnetism Level*

For Variant 01 the following codes shall be used for magnetism level:

Code	Definition
NMB	Magnetism Level: ≤ 200 gamma
NMC	Magnetism Level: ≤ 20 gamma
NMD	Magnetism Level: ≤ 2 gamma

For Variant 02 magnetism level is not applicable and therefore the magnetism level code shall be omitted.

4.5.5 Traceability Information

Traceability information shall be marked in accordance with the requirements of ESCC Basic Specification No. [21700](#).

4.6 ELECTRICAL MEASUREMENTS

4.6.1 Electrical Measurements at Room Temperature

The parameters to be measured in respect of electrical characteristics are scheduled in Table 2. Unless otherwise specified, the measurement shall be performed at $T_{amb} = +22 \pm 3$ °C.

4.6.2 Electrical Measurements at High and Low Temperatures (Table 3)

Not applicable.

4.6.3 Circuit for Electrical Measurements (Figure 4)

Not applicable.

4.7 BURN-IN AND ELECTRICAL MEASUREMENTS (TABLES 4 AND 5)

Not applicable.

TABLE 2 - ELECTRICAL MEASUREMENTS AT ROOM TEMPERATURE

No.	Characteristic	Symbol	ESCC 3401 Test Method	Test Condition	Limits		Unit
					Min	Max	
1	Insulation Resistance	R_i	Para. 9.1.1.1	Para. 9.1.1.1	5000	-	M Ω
2	Voltage Proof Leakage Current	I_L	Para. 9.1.1.2	600Vrms	-	2	mA
3	Low Level Contact Resistance	R_{cl}	Para. 9.1.1.3	Para. 9.1.1.3	-	6	m Ω
4	Rated Current Contact Resistance	R_{cr}	Para. 9.1.1.3	Table 1(b)	-	5	m Ω

TABLES 3, 4 AND 5

Not applicable.

FIGURE 3 – TEST PINS FOR CONTACT ENGAGEMENT AND SEPARATION FORCES TEST

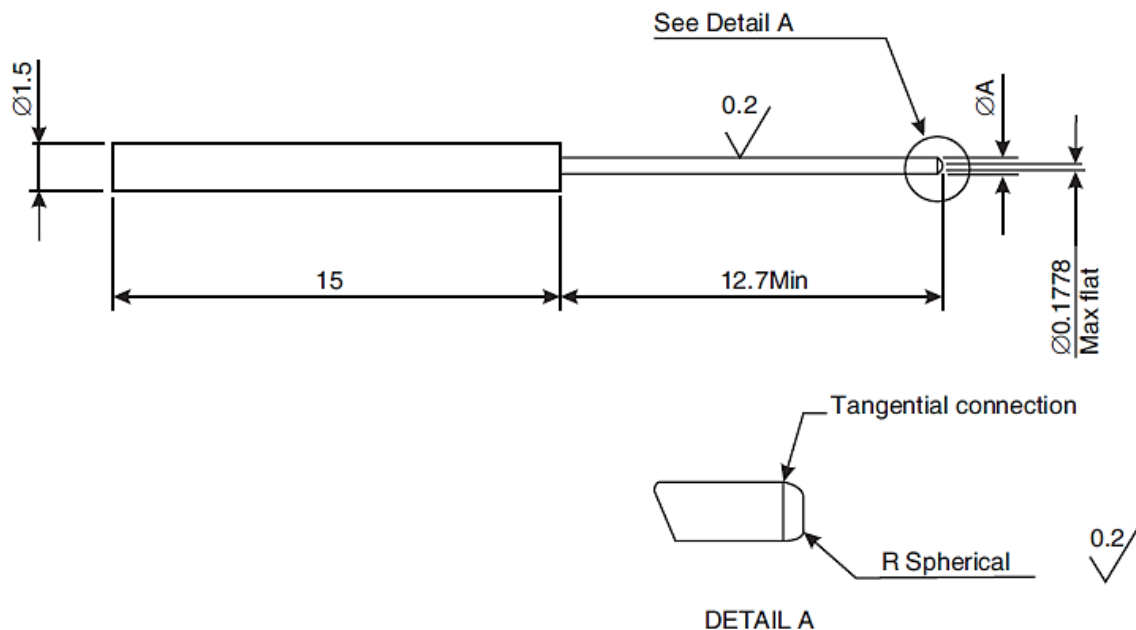

NOTES:

All dimensions are in millimetres.

Test pin $\varnothing A$: as specified in Para. 4.3.9 herein.

Test pin materials: tool steel or tungsten carbide with a surface roughness of 0.2 μ m.

4.8 ENVIRONMENTAL AND ENDURANCE TESTS (CHARTS IV AND V OF ESCC GENERIC SPECIFICATION NO. 3401)

4.8.1 Measurements and Inspections on Completion of Environmental Tests

The parameters to be measured and inspections to be performed on completion of environmental testing shall be those specified in Table 6. Unless otherwise specified, these measurements shall be performed at $T_{amb} = +22 \pm 3$ °C.

- 4.8.2 Measurements and Inspections at Intermediate Points during Endurance Tests
Not applicable.
- 4.8.3 Measurements and Inspections on Completion of Endurance Tests
The parameters to be measured and inspections to be performed on completion of endurance testing shall be those specified in Table 6. Unless otherwise specified, the measurements shall be performed at $T_{amb} = +22 \pm 3 \text{ }^\circ\text{C}$.
- 4.8.4 Conditions for Operating Life Test (Part of Endurance Testing)
Not applicable.
- 4.8.5 Electrical Circuit for Operating Life Test (Figure 5)
Not applicable.
- 4.8.6 Conditions for High Temperature Storage Test (Part of Endurance Testing)
The requirements for the high temperature storage test are specified in Section 9 of ESCC Generic Specification No. 3401. The temperature to be applied shall be the maximum storage temperature specified in Table 1(b) of this specification.

TABLE 6 - MEASUREMENTS AND INSPECTIONS ON COMPLETION OF ENVIRONMENTAL AND ENDURANCE TESTING

No.	ESCC Generic Spec. No. 3401		Measurements and Inspections		Symbol	Limits		Unit
	Environmental and Endurance Tests (Note 1)	Test Method and Conditions	Identification	Conditions		Min	Max	
01	Seal Test	Para. 9.9	Not applicable	-	-	Not applicable		-
02	Wiring	Para. 9.10	Not applicable	-	-	-	-	-
03	Vibration	Para. 9.11	Initial Measurements	-	-	Not applicable		-
			Coupling screw(s) Unlocking Torque					
			Final Measurements					
			Full Engagement	-	-	Not applicable		-
			Coupling screw(s) Unlocking Torque Drift					
			Visual Examination					
04	Shock or Bump	Para. 9.12	Full Engagement	-	-	-	-	-
			Visual Examination					

No.	ESCC Generic Spec. No. 3401		Measurements and Inspections		Symbol	Limits		Unit
	Environmental and Endurance Tests (Note 1)	Test Method and Conditions	Identification	Conditions		Min	Max	
05	Climatic Sequence	Para. 9.13	Dry Heat Insulation Resistance Low Air Pressure Voltage Proof Leakage Current Damp Heat Insulation Resistance Final Measurements External Visual Inspection Insulation Resistance Voltage Proof Leakage Current	Table 2, Item 1 Figure 1 Immediately after test Table 2, Item 1 After 1-24 hrs Recovery ESCC 3401 Para. 9.7 Table 2, Item 1 Table 2, Item 2	R _i I _L R _i R _i I _L	10 - Table 2 Item 2 1 - ESCC 3401 Para. 9.7 Table 2, Item 1 Table 2, Item 2	MΩ mA MΩ MΩ mA	
06	Plating Thickness	Para. 9.14	Thickness	-	-	Para. 4.4.4 of this spec.		-
07	Joint Strength	Para. 9.15	Not applicable	-	-	Not applicable		-
08	Rapid Change of Temperature	Para. 9.16	Visual Examination Insulation Resistance Voltage Proof Leakage Current	- Table 2, Item 1 Table 2, Item 2	- R _i I _L	- - Table 2, Item 1 Table 2, Item 2	- MΩ mA	
09	Contact Retention (in Insert)	Para. 9.17 & Para. 4.3.4 of this spec.	Contact Displacement	-	-	ESCC 3401 Para. 9.17		-
10	Endurance	Para. 9.18	Initial Measurements Mating/Unmating Forces Low Level Contact Resistance Mated Shell Conductivity Final Measurements Visual Examination Mating/Unmating Forces Low Level Contact Resistance Drift Mated Shell Conductivity Insulation Resistance Voltage Proof Leakage Current	- Table 2, Item 3 - - - - Table 2, Item 3 - Table 2, Item 1 Table 2, Item 2	F R _{cd} - - F ΔR _{cd} - R _i I _L	Para. 4.3.5 of this spec. Table 2, Item 3 Record Values Not applicable - - Para. 4.3.5 of this spec. - 3 Not applicable Table 2, Item 1 Table 2, Item 2	N mΩ - N mΩ - MΩ mA	
11	Permanence of Marking	Para. 9.19	As applicable	-	-	-	-	-
12	Mating/Unmating Forces	Para. 9.20	Force	-	F	Para. 4.3.5 of this spec		N

No.	ESCC Generic Spec. No. 3401		Measurements and Inspections		Symbol	Limits		Unit
	Environmental and Endurance Tests (Note 1)	Test Method and Conditions	Identification	Conditions		Min	Max	
13	High Temperature Storage	Para. 9.21	Initial Measurements Low Level Contact Resistance Mated Shell Conductivity Final Measurements Visual Examination Mating/Unmating Forces Low Level Contact Resistance Drift Rated Current Contact Resistance Mated Shell Conductivity Insulation Resistance Voltage Proof Leakage Current Contact Retention (in Insert)	Table 2, Item 3 - - - - Table 2, Item 3 Table 2, Item 4 - Table 2, Item 1 Table 2, Item 2 Para. 4.3.4 of this spec.	R _{cl} - - F ΔR _{cl} R _{cr} - R _i I _L -	Table 2, Item 3 Record Values Not applicable - - Para. 4.3.5 of this spec. - 3 Table 2, Item 4 Not applicable Table 2, Item 1 Table 2, Item 2 ESCC 3401 Para. 9.17	mΩ - - N mΩ mΩ - MΩ mA N	
14	Corrosion	Para. 9.22	Visual Examination	-	-	-	-	-
15	Insert Retention (in Shell)	Para. 9.23 & Para. 4.3.6 of this spec.	Visual Examination	-	-	Para. 4.3.6 of this spec.		-
16	Jackscrew Retention	Para. 9.24 and 4.3.7 of this spec	Visual Examination	-	-	Not applicable		-
17	High Temperature Measurements	Para. 9.25	Insulation Resistance	Table 2 Item 1 (Note 2)	R _i	10	-	MΩ
18	Overload Test	Para. 9.26	Internal Temperature Rated Current Contact Resistance Mated Shell Conductivity Insulation Resistance Voltage Proof Leakage Current	- Table 2, Item 4 - Table 2 Item 1 Table 2 Item 2	T R _{cr} - R _i I _L	- +100 Table 2, Item 4 Not applicable Table 2, Item 1 Table 2, Item 2	°C mΩ - MΩ mA	
19	Maintenance Aging	Para. 9.27	Not applicable	-	-	Not applicable		-
20	Engage/Separation Forces	Para. 9.28 & Para. 4.3.9 of this spec.	Force	-	F	Para. 4.3.9 of this spec.		N
21	Oversize Pin Exclusion	Para. 9.29 and 4.3.10 of this spec.	-	-	-	ESCC 3401 Para. 9.29		-
22	Probe Damage	Para. 9.30 and 4.3.11 of this spec.	Contact Separation Force	Para. 4.3.9 of this spec.	-	Para. 4.3.9 of this spec.		-

No.	ESCC Generic Spec. No. 3401		Measurements and Inspections		Symbol	Limits		Unit
	Environmental and Endurance Tests (Note 1)	Test Method and Conditions	Identification	Conditions		Min	Max	
23	Solderability	Para. 9.31 & Para. 4.3.12 of this spec.	Not applicable	-	-	Not applicable		-

NOTES:

1. The tests in this Table refer to either Chart IV or V and shall be used as applicable.
2. $T_{amb} = +125\text{ }^{\circ}\text{C}$.