

Single Event Transient Characterisation of Analog IC's for ESA's Satellites

R. Harboe-Sørensen¹, F.X. Guerre², H. Constans², J. van Dooren¹, G. Berger³ and W. Hajdas⁴

¹European Space Agency/ESTEC, Noordwijk, The Netherlands.

²HIREX Engineering, Toulouse, France.

³Universite Catholique de Louvain, Louvain-la-Neuve, Belgium.

⁴Paul Scherrer Institut, Villigen, Switzerland.

Abstract

The analysis of four self switch-off events in power supply on-board ESA's SOHO satellite point strongly in the direction of being cosmic ray or proton induced. Detailed analysis of the relevant power supply schematics identified a number of analog IC's capable of causing or contributing to such events [1][2][3][4][5].

This paper details the effort taken in order to characterise the upset sensitivity of the various analog IC's flown. Testing aspects and Single Event Transient (SET) results will be presented. Ground testing, simulating the flight conditions, were carried out at both heavy ion and proton accelerators.

I. INTRODUCTION

The SOHO (Solar and Heliospheric Observatory) satellite orbiting at the Lagrangian point L1 about 1.5 million km from the earth, is a ESA/NASA scientific satellite. During three years of successful operations, SOHO experienced four power supply switch-off events, two in the service module and two in the payload module, all recoverable. Even though SOHO operates in a relative quiet environment regarding Galactic Cosmic Rays, these four events were believed to originate from space radiation as Single Event Upset (SEU) in one or more of the following analog semiconductor IC's:

LM/PM139 Quad Voltage Comparator
UC1707J Dual Channel Power Driver
UC1842J Current Mode PWM Controller
RH1078 Dual, Single Supply, Precision Op Amp

However, lacking detailed knowledge of these components SEU/SET behaviour when used in the various SOHO designs, a major ground test program was put together. This program, funded by ESA's next scientific satellite XMM (X-Ray Multi-Mirror), had high priority, as several of SOHO's power supply designs are re-used in XMM. As circuit design,

bias conditions and device type (lot) tested have substantial influence on the measured upset sensitivity [3][4][5], high priority was given to re-produce flight conditions and use flight lot devices for testing. In addition and for comparison, a few tests were carried out running the devices in comparator or amplifier mode or using non-flight devices.

II. DEVICES TESTED

The four self switch-off events occurred in power supplies using the following IC's:

a) – BA-ACU PSU	PM139, UC1707J and UC1842J
b) – CDMU PCCS	PM139 and UC1707J
c) – LASCO PSU	PM139 and UC1707J
d) – VIRGO PSU	PM139

Flight lot devices, as detailed as ID 1 to 4 in Table 1, were SEU/SET characterised during this ground test program. In addition to these four types (also including a TERMA RH1078 design), LM139 devices from National Semiconductor and LM339 devices from ST Microelectronics (functionally compatible with the LM139), were also included for comparison.

So overall, six device types were ground SEU/SET characterised using various SOHO/XMM designs and operating conditions, during heavy ion and proton accelerator testing.

III. TEST SYSTEM and TEST FACILITIES

The overall test system consists of a standard test rack, PC controlled, and various application specific test boards. A mother board design allows up to 4 application specific test boards to be installed at the same time. Multiplexed operation allows DUT error recording and a digital oscilloscope waveform monitoring.

Device characterisation were conducted at the Heavy Ion Irradiation Facility at Cyclone, UCL, Belgium and at the Proton Irradiation Facility, PSI, Switzerland. Accelerator details, test set-ups and beams used can be found in [6][7].

Table 1. Analog IC identification chart.

SOHO/XMM FLIGHT LOT DEVICES - SEE TESTED 1998						
ID s/n	DEVICE	MANUFACTURER MARKING/DATE CODE	DIE MARKING		PACKAGE	FUNCTION
				DIE mm ²		
1	UC1707J	Unitrode SIC01-01002B OC9145	BIPOLAR 1707 SMG U84	5.56	CERDIP DIL-16C	Dual Channel Power Driver
2	UC1842J	Unitrode SIC01-00902B OC9146	BIPOLAR 1842 U85	4.20	CERDIP DIL-8C	Current Mode PWM Controller
3	RH1078	Linear Technology XMIG0067 01BR 9638A	BIPOLAR M 1987	5.51	CERDIP DIL-8C	Dual, Single Supply, Precision Op Amp
4	PM139	Analog Devices/PMI JM38510/11201SCA 9524A	BIPOLAR 3003Y 1987	1.50	CERDIP DIL-14C	Quad Voltage Comparator
5	LM139J	National Semiconductor LM139J B9718AB	BIPOLAR 1901F	1.32	CERDIP DIL-14C	Quad Voltage Comparator
6	LM339	ST Microelectronics LM339D1 9836	BIPOLAR 0339 ST 1993	1.82	Side-B DIL14C	Quad Voltage Comparator

IV. TEST CONDITIONS and RESULTS

In the following, test schematics, test conditions and test results will be presented per device type/test set-up, however, for convenience test conditions have also been summarised in Table 2. This table lists the device type tested and test set-up, the supply voltage applied (PV1), the input levels used (VI1 and VI2), and the output levels required for a SET recording (F01/F02/F03). Arrows indicate polarity of SET measured. Levels in *Italic* are single output level events binned via window comparators. Schematic latch(ed) SEU, identified as output-3 events (L01/F03), are permanent and verified latch(ed) changes.

UC1707J - Dual Channel Power Driver

Two XMM designs, one based on a BA ACU schematic and one on a LASCO schematic, were converted into accelerator SEU test set-ups. The BA ACU test set-up can be seen in Figure 1 and the LASCO test set-up in Figure 4. Schematics within the dotted area represent the flight design.

Test Schematics/Conditions – 1707 BA ACU

In this 1707 design to detect over-voltage, additional components have been added for simulating upsets, for automatic reset of latches (after a wait state of 1 ms) and a transient filter. Transient events can be counted at F01 as driver output events, at F02 as comparator output events and at L01 (F03) as latch state changes. Testing was performed with input levels as a) Condition-1: VI1 = 6.2 V and VI2 = 6.5 V and b) Condition-2: VI1 = 6.2 V and VI2 = 6.0 V.

Heavy Ion Results – 1707 BA ACU

Heavy ion SET results for the two test conditions are shown in graphical form in Figure 2 and Figure 3, respectively. These graphs show (x-lin, y-log), as a function of LET, the transient upset cross section (cm²/Device) for driver output and

latched SEU output, averaged for two devices tested. Noticeable is, that the comparator output follows the latch state (nearly the same number of events) - which is not in line with the UC1707 datasheet! Also note the higher number of latch SEU errors in test condition-1 (tested close to the comparator trigger level) compared to test condition-2 (far from comparator trigger level). Testing with a 1 nF filter capacitor decreased significantly the number of latch SEU events. With a 10 nF capacitor added, all comparator event (latch SEU) disappeared.

Proton Results – 1707 BA ACU

Proton testing at 300 MeV using test condition-1 resulted in 4 driver output events and 4 latched SEU output (comparator) events over a fluence of 2E11 protons/cm² (approximately 8.0 Krad(Si)). Test condition-2 gave zero events over the same fluence.

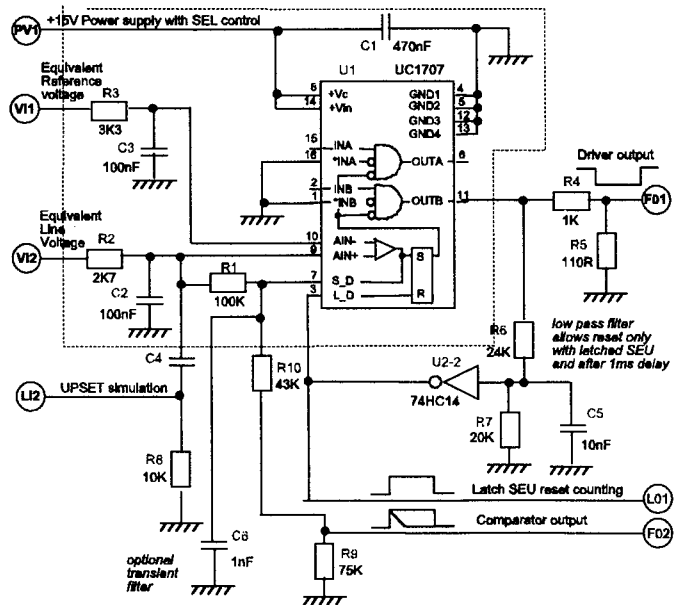

Figure 1. UC1707 Test schematics/set-up BA ACU.

Table 2. Summary of test conditions.

Test Set-Up/ Conditions	PVI Supply	VII Input	VI2 Input	FO1 Output-1	FO2 Output-2	FO3/LO1 Output-3
1707 BA C-1.	15.0 V	6.2 V	6.5 V	10.0V ↓	800mV ↑	2.5V ↑
1707 BA C-2.	15.0 V	6.2 V	6.0 V	10.0V ↓	800mV ↑	2.5V ↑
1707 Lasco C-1.	15.0V	6.0 V	3.0 V	10.0V ↓	800mV ↑	-
1707 Lasco C-2.	15.0V	6.2 V	6.1 V	10.0V ↓	800mV ↑	-
1078 Terma	15.0V	4.1 V	4.0 V	4.0V ↓	4.0V ↓	2.5V ↑
1078 Op Amp	15.0V	4.5 V	-	50mV ↓ ↑	400mV ↓ ↑	6.2V ↓ ↑
1842 Pulse M.	15.0V	1.5 V	-	8.0V ↑	16.0V ↑	-
LM139 VIRGO	10.0V	300mV	290mV	5.0V ↓	8.0V ↓	2.5V ↑
LM139 Comp.	10.0V	100 mV	50 mV	8.0V ↓	2.0V ↓	-

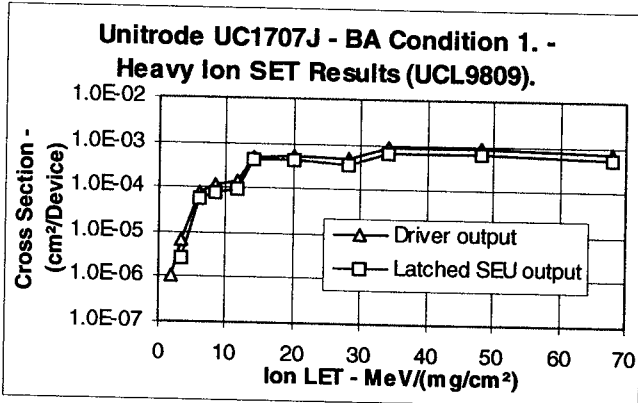

Figure 2. Heavy ion SET results for BA ACU condition-1.

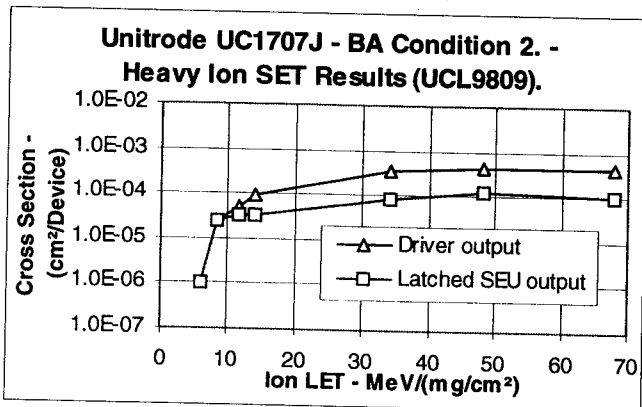

Figure 3. Heavy ion SET results for BA ACU condition-2.

Test Schematics/Conditions – 1707 LASCO

This 1707 design with the comparator input used as an on/off signal have event detection at F01 as driver output events and at F02 as comparator output events, see Figure 4. Testing was performed with differential input levels as c) Condition-1: VII = 6.0V and VI2 = 3.0V and d) Condition-2: VII = 6.2V and VI2 = 6.1V.

Heavy Ion Results – 1707 LASCO

Heavy ion SET results for LASCO test condition-1 and test condition-2 are shown in Figure 5. Again the test results are presented per device for driver output events averaged for the two devices tested. The two test conditions show the same driver output sensitivity without any comparator events recorded.

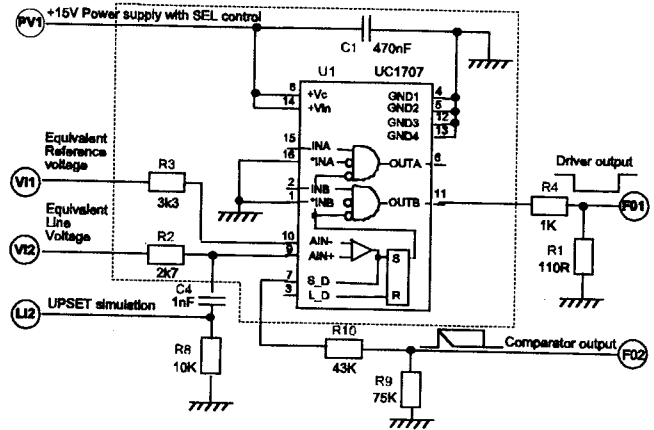

Figure 4. UC1707 Test schematics/set-up LASCO

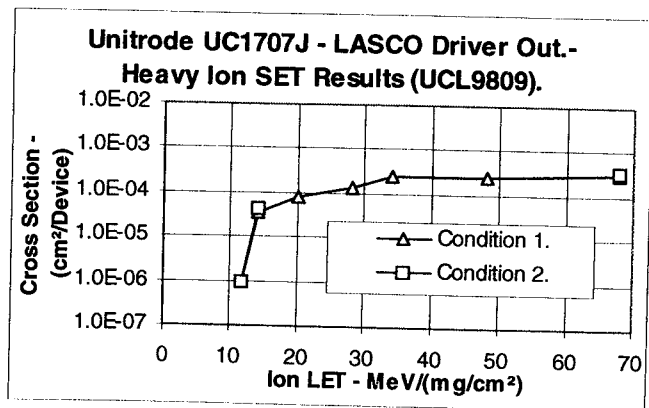

Figure 5. Heavy ion SET driver output results for LASCO.

Oscilloscope captures of SET events showed comparator events with amplitudes too small to be counted. A typical upset event, oscilloscope captured is shown in Figure 6. Note that the SEU on the comparator causes a transient on the driver output. Also note the reaction of the latch transient on the comparator.

Proton testing was not carried out due to the high heavy ion LET SET threshold.

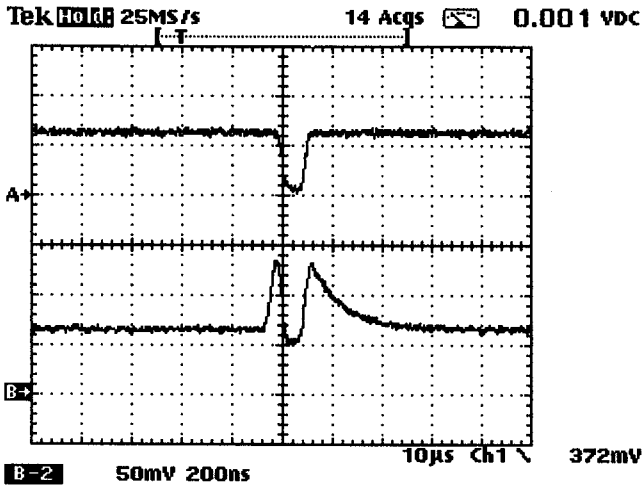

Figure 6. LASCO oscilloscope records A (upper) Driver output (10V/div) – B (lower) Comparator (200mV/div).

UC1842J – Current Mode PWM Controller

Test Schematics/Conditions - UC1842

This test set-up providing simulation of instantaneous pulse current control mode and does not refer to any specific XMM design. The falling edge of the output signal is monitored as it allows for detection of any periodic change since it is the edge used in the duty cycle regulator. It is implemented via a PLL circuit with edge triggered phase comparator locked on the falling edge. PLL circuit used in the test board provides a logic signal giving the absolute phase error. This logic signal is processed via a RC filter used to convert pulse width into transient amplitudes. Two counters with programmable thresholds monitor these transients. Counter 1 (F01) counts small errors = phase shift errors and counter 2 (F02) counts large errors = period mismatch. Test set-up schematics is detailed in Figure 7 and test conditions in Table 2.

Heavy Ion Results - UC1842

Heavy ion SET results is shown in Figure 8. SET's are presented per device as small and large events averaged for the two devices tested. The small errors correspond very likely to a small variation in the expected falling edge with areas of concern being the amplifier, the current comparator and the RS latch. The large errors correspond very likely to an upset in the internal PWM oscillator area resulting in a reduction of the off state duration. Worst case would correspond to two consecutive on states without an intermediate off state. In actual power supply configurations, the inductor current level can not decrease

instantaneously, so the second on state should be shorter. Oscilloscope image, Figure 9, show a typical upset in the internal PWM oscillator resulting in a shift of the rising edge of the output (from heavy ion run using Ne-ions at a LET = 11.7 MeV/(mg/cm²)).

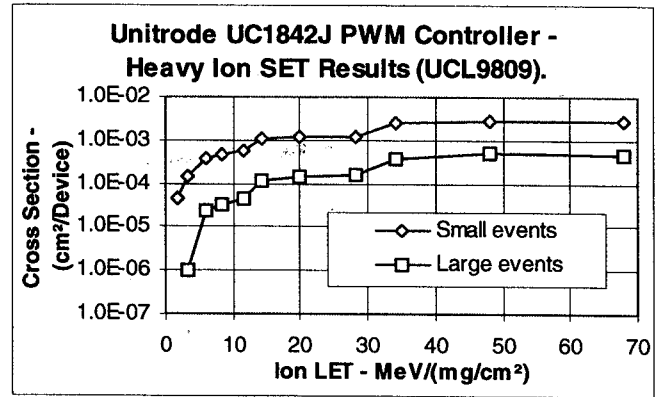

Figure 8. UC1842 Heavy ion SET results, small events = phase shift errors, large events = period mismatch.

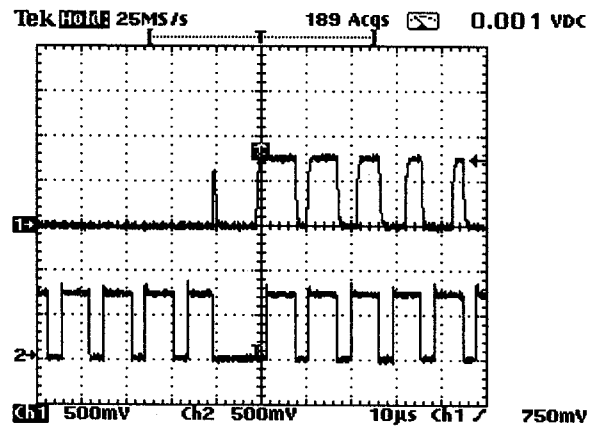

Figure 9. UC1842 PWM oscilloscope record - (upper) phase comparator output - (lower) internal output shift.

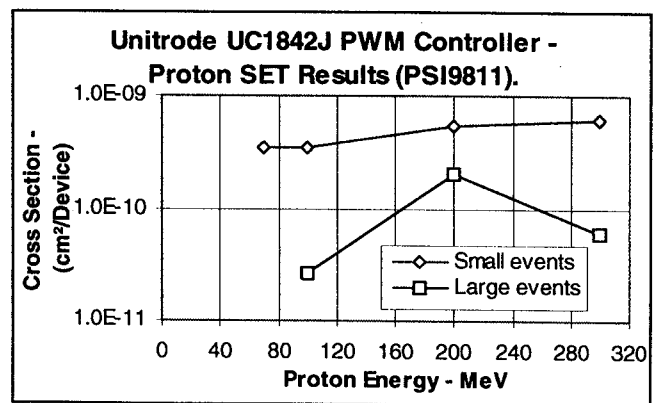

Figure 10. UC1842 Proton SET results, small events = phase shift errors, large events = period mismatch.

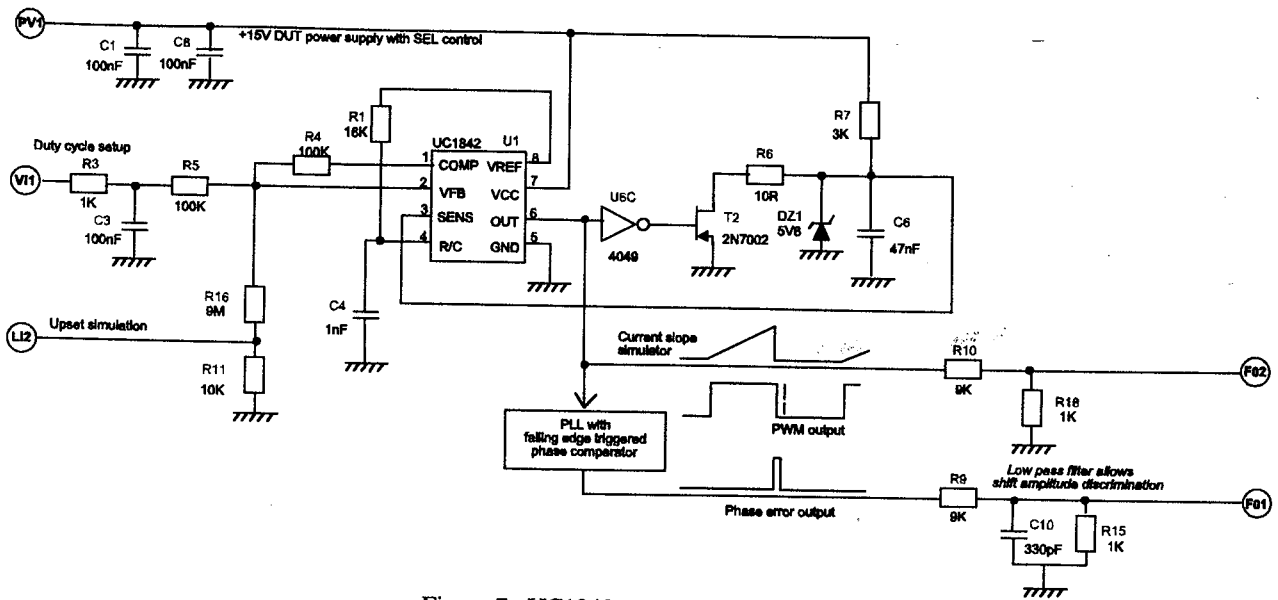

Figure 7. UC1842 Test schematics/set-up

Proton Results - UC1842

Proton SET results is shown in Figure 10. Again SET are presented per device as small and large events averaged for the two devices tested. The SET upset cross section is presented as a function of proton energy. The strange shape of the cross section curve for large events is due to poor statistics (8 events at 200 MeV – 3 events at 300 MeV for the same fluence), however, a worst case SET cross section sensitivity can be extrapolated.

RH1078 – Micropower Dual Op Amp

One XMM design, based on a TERMA schematic, was converted into a SEU test set-up usable at the accelerator. The RH1078 was also tested in a component oriented test configuration as a stand-alone Close Loop Amplifier. These two test schematics/set-ups can be seen in Figure 11 and Figure 13, respectively.

Test Schematics/Conditions - RH1078 TERMA

In this TERMA RH1078 design (within dotted area) the dual amplifier is configured as a latched command. The first amplifier is used as a comparator that will trigger a flip of the bistable element formed by the second amplifier, when the comparator input level exceeds a given threshold. However, re-initialisation of the TERMA design requires a power off/on. So for this test set-up additional components have been added for simulating upsets, for automatic reset of latches (after a wait state of 1 ms) and for continuous testing without a power off/on. Transient events can be counted at F01 as latch output events, at F02 as comparator output events and at L01 (F03) as latched SEU events. Testing was performed with input levels as a) Condition-1 close to triggering: VII= 4.1 V and b) Condition-2 far from triggering: VII= 3.6 V.

Heavy Ion Results - RH1078 TERMA

Heavy ion SET results for test condition-1 is shown in Figure 12. This graph show (x-lin, y-log), as a function of LET, the transient upset cross section ($\text{cm}^2/\text{Device}$) for comparator output events, for latch events and for latched SEU events, averaged for the two devices tested. Note that both amplifiers were exposed during these tests, thus producing comparator errors events (first DUT amplifier) and latch events (second DUT amplifier). A large portion of these events result in permanent latched SEU events, as shown in Figure 12. Test condition-2 results showed a very similar behaviour as test condition-1 with saturated latched SEU events having a cross section of about $1.0\text{E-}4 \text{ cm}^2/\text{device}$. No latched SEU events were recorded when testing was carried out with the 100 nF transient filter capacitor incorporated (up to a LET of 68.0 MeV/(mg/cm²)). Proton testing was not carried out due to the high heavy ion LET SET threshold.

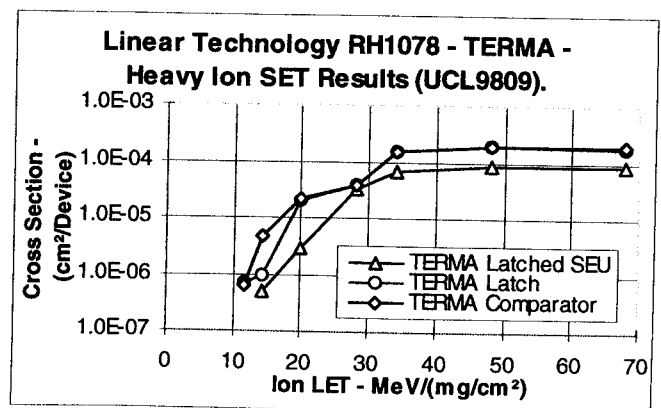

Figure 12. Heavy ion SET results for RH1078, TERMA condition-1.

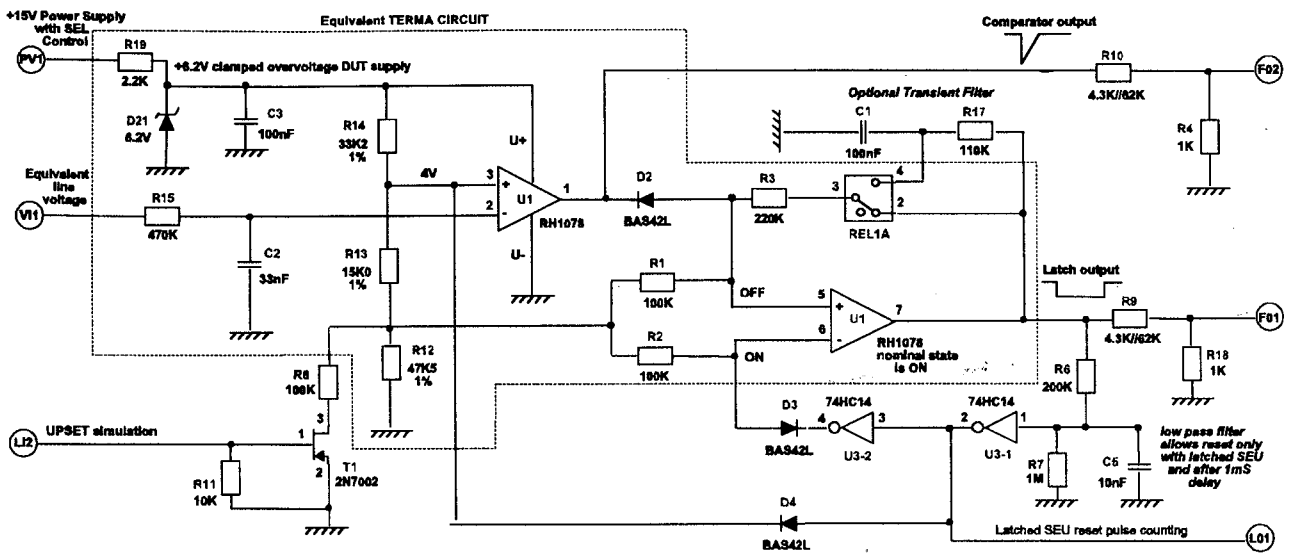

Figure 11. RH1078 TERMA Test schematics/set-up

Test Schematics/Conditions - RH1078 Op Amp

In this RH1078 test design the amplifier is used in a closed loop configuration with a large differential gain. The detection of events will be done with an analog window comparator system, not shown in Figure 13. Errors will be categorised as transient upsets with amplitudes; small LO1 = >50 mV, medium LO2 = >400 mV and large LO3 = >6.25 V. Input test condition-1 will be with VI1 = 0.5 V (only one test performed) and test condition-2 with VI1 = 4.5 V.

Heavy Ion Results - RH1078 Op Amp

Heavy ion SET results for test condition-2 is shown in graphical form in Figure 14. Here cross section results per cm² per amplifier are presented as a function of LET for small and medium amplitude events (averaged for two devices).

threshold setting for large events of 6.25 V. Figure 15 also show the transient duration's to vary between 1.5 and 3.5 μ sec.

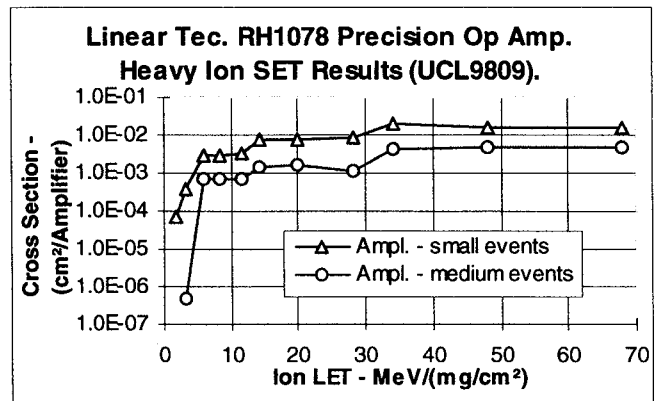

Figure 14. Heavy ion SET results for RH1078, Op Amp condition-2.

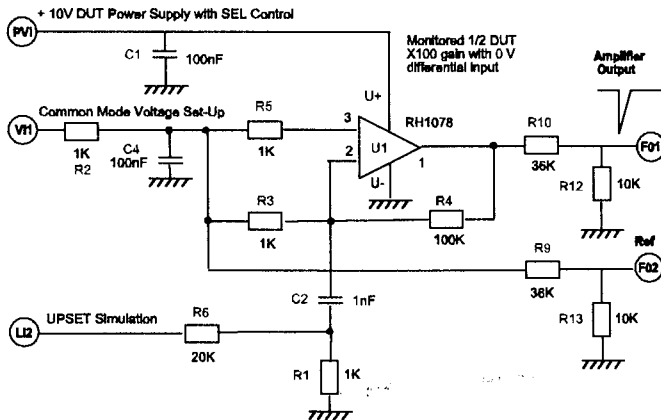

Figure 13. RH1078 Op Amp test schematics/set-up

Seeing no large events in any of the tests, a set of oscilloscope captures showed the reason. As can be seen in Figure 15, errors had maximum amplitudes of about 2 volt, far below the

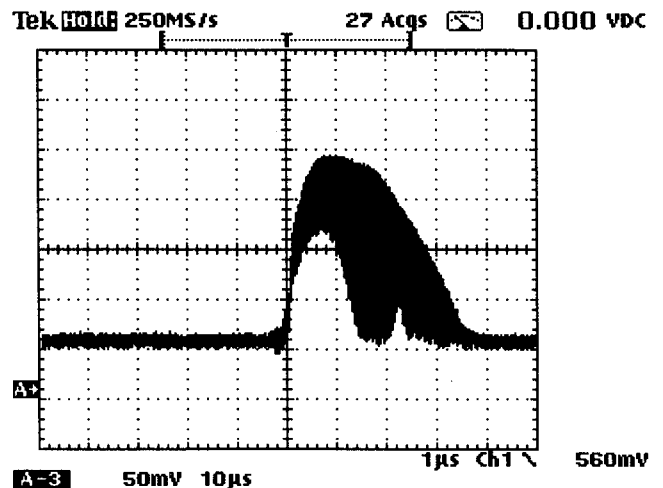

Figure 15. RH1078 Op Amp oscilloscope record - envelope of medium events. .

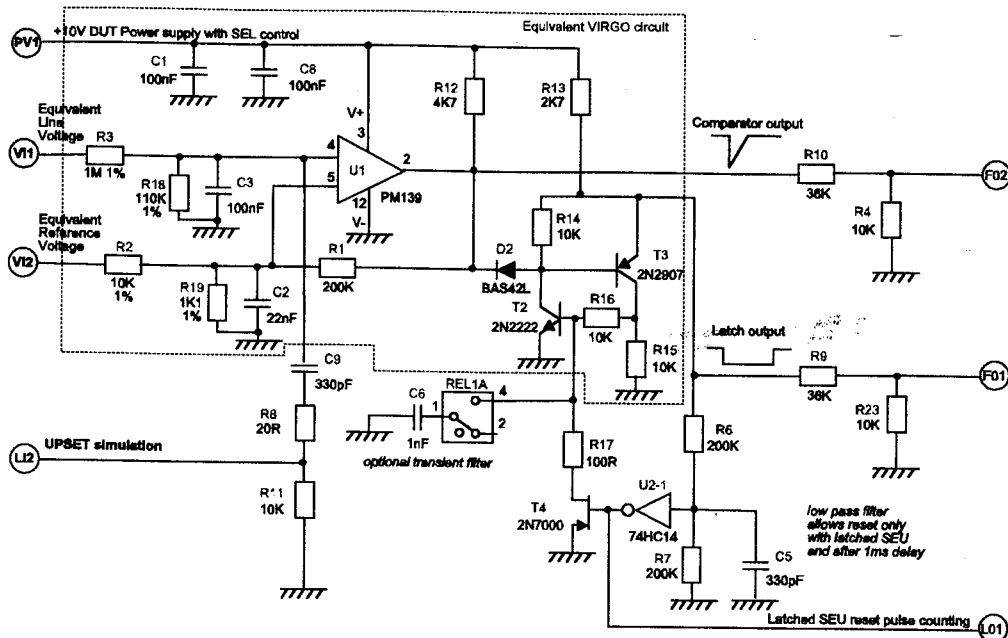

Figure 17. LM/PM139 VIRGO Test schematics/set-up

Proton Results - RH1078 Op Amp

Proton SET results for test condition-2 is shown in a graphical form in Figure 16. Here cross section results per cm² per amplifier are presented as a function of proton energy for small events. As only 4 medium events were recorded during these tests (at 300 MeV and a fluence of 5.0E10 p/cm²), proton induced transient can be concluded to have limited amplitudes.

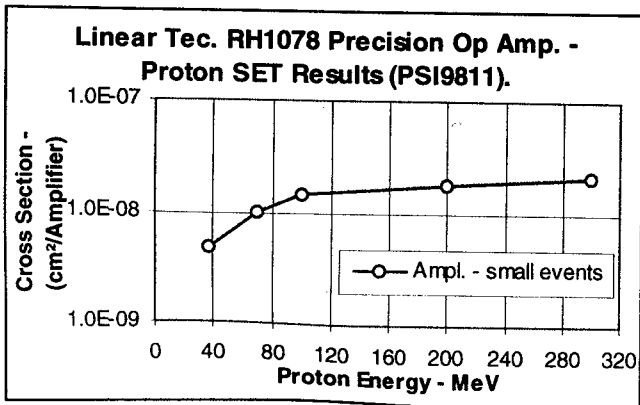

Figure 16. Proton SET results for RH1078 Op Amp.

LM/PM139 – Quad Voltage Comparator

One XMM design based on a VIRGO schematic was converted into a SEU test set-up usable at the accelerator. In addition, LM/PM139's were also tested in a comparator test configuration. These two test schematics/set-ups can be found in Figure 17 and Figure 18, respectively.

Test Schematics/Conditions – LM/PM139 VIRGO

In this VIRGO LM/PM139 design (within dotted area).

the comparator is used as a latched command, that is triggered when the comparator input level, exceeds a given threshold. However, re-initialisation of the VIRGO design requires a power off/on. So for this test set-up additional components have been added for simulating upsets, for automatic reset of latches (after a wait state of 1 ms), for transient suppression (filter capacitor) and for continuous testing without a power off/on (resistor added to the Base of T02). Transient events can be counted at F01 as latch output events, at F02 as comparator output events and at L01 (F03) as latched SEU events. Testing was performed with input levels of: V11= 300 mV and V12=290 mV. Test set-up schematic is detailed in Figure 17 and test conditions in Table 2.

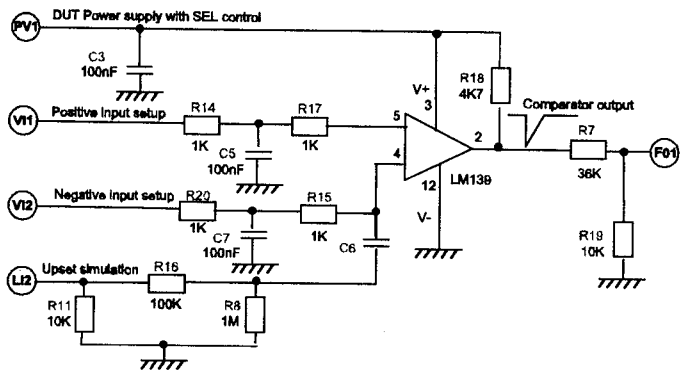

Figure 18. LM/PM139 Comparator Test schematics/set-up

Test Schematics/Conditions – LM/PM139 Comparator

In this LM/PM139 test design the comparator function itself is tested with the amplifier output saturated. The output signal direction depends on the relative magnitude of the two comparator inputs. SET are detected and counted via analog windows (not shown in Figure 18). Large events, corresponding

to a 2.0 V threshold, thus comparator outputs with amplitudes higher than 8.0 Volt and small events, corresponding to a 8.0 V threshold, thus comparator outputs with amplitudes higher than 2.0 Volt, are counted. Testing was performed with input levels of: VI1= 100 mV and VI2=50 mV. Test set-up schematic is detailed in Figure 18 and test conditions in Table 2.

Heavy Ion Results – LM/PM139 VIRGO

Initial heavy ion testing using the VIRGO test set-up showed that nearly every transient detected at the comparator output (F02) is also detected at the latch output (F01) and cause the latch circuit to change, latched SEU (L01). This was verified over several tests (LET range 14.1 to 34.0 MeV/(mg/cm²) and using devices from all three LM/PM139 manufacturer. So in order to evaluate this design, further testing was carried out with the 1 nF filter capacitor incorporated (see Figure 17).

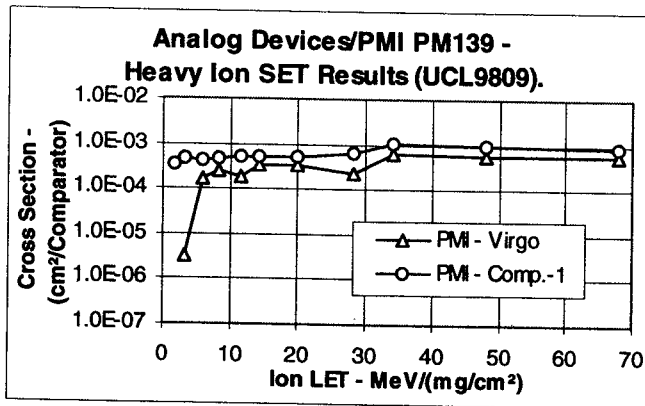

Figure 19. Heavy ion SET results – Analog D./PMI PM139.

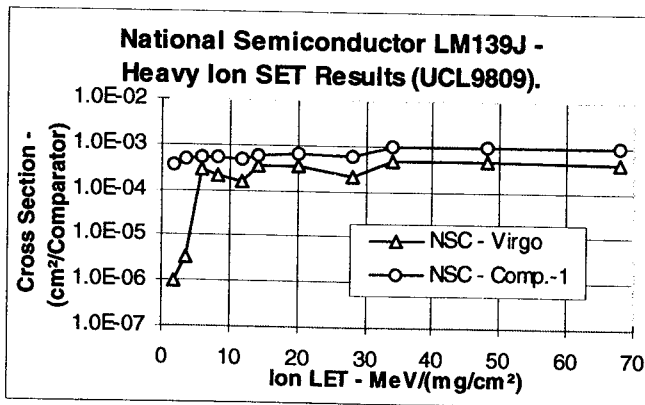

Figure 20. Heavy ion SET results – NS LM139.

VIRGO heavy ion SET results (comparator output) are shown in a graphical form in Figure 19 (for Analog Devices/PMI), in Figure 20 (for National Semiconductor) and in Figure 21 (for ST Microelectronics). Here cross section results

per cm² per comparator are presented as a function of LET (averaged for two devices). Latch output errors were counted at nearly the same rate whereas none of the tests showed any latched SEU events anymore. However, without the filter capacitor (VIRGO design) LM/PM139 transient would activate the latch at rates as presented in Figures 19, 20 and 21.

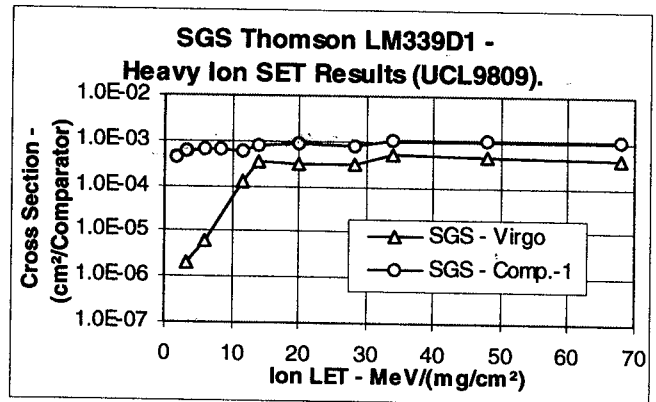

Figure 21. Heavy ion SET results – STM LM339D1.

Heavy Ion Results – LM/PM139 Comparator

Comparator heavy ion SET results for the three types can also be found in Figures 19, 20 and 21. Again results are presented as average for two devices - for small events. However, as nearly all error events also get recorded as large events, only one SET curve has been reported per LM/PM139. When comparing these curves in Figures 19, 20 and 21, hardly any variation in their heavy ion cross section sensitivity can be seen. A typical envelope of SET events, oscilloscope captured, can be seen in Figure 22. Note that the recorded amplitudes come close to 10 Volt and that the transient duration approaches 2 μseconds.

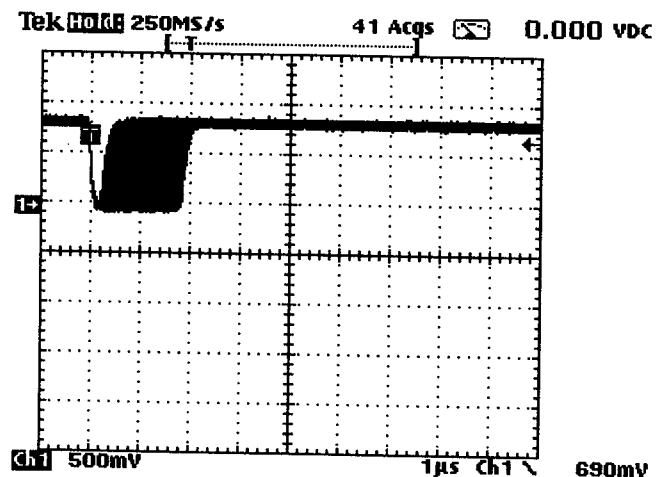

Figure 22. LM139 NS, Heavy ion SET envelope. (5V/div – 1 μsec/div)

LM/PM139 devices tested in the VIRGO design showed a very low sensitivity to proton induced events. No SET events were recorded at 300 MeV for Analog Devices/PMI to a fluence of 1.1×10^{11} p/cm² whereas National Semiconductor showed 1 event over a fluence of 1.0×10^{11} p/cm². STM was not tested.

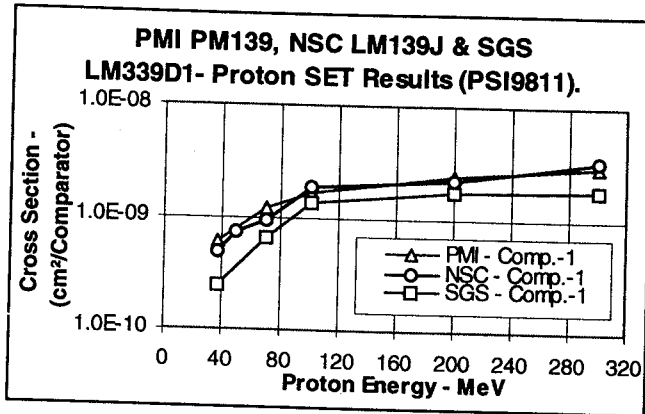

Figure 23. Proton SET results – PM/LM139.

Proton Results – LM/PM139 Comparator

Proton comparator SET results for all three manufacturers are shown in Figure 23. SET results are presented per comparator as a function of proton energy for small events averaged for two devices tested per type. Minor variation in SET cross section sensitivity can be reported with ST Microelectronics showing the lowest rate. Transient characteristics for Analog Devices/PMI are shown in Figure 24 (s/n #683 tested with 300 MeV protons). This oscilloscope capture shows nearly the same ‘envelope’ as for heavy ion testing. Amplitudes come close to 10 Volt and duration’s up to 1.5 μ sec. So both heavy ion and proton causes events of the same magnitude.

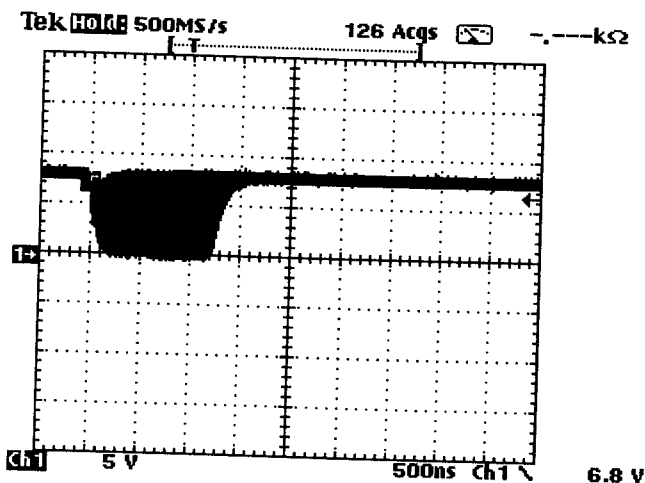

Figure 24. PM139 AD/PMI Proton SET envelope. (5V/div – 500 ns/div)

V. CONCLUSIONS

Heavy ion and proton upset characterisation of XMM designs covering a BA ACU UC1707 design, a LASCO UC 1707 design, a TERMA RH1078 design and a VIRGO PM139 design, all showed to be single event transient (SET) sensitive. Further the XMM used UC1842, not tested in a XMM configuration, also showed to be SET sensitive. Also high SET sensitivities were recorded when testing the RH1078 in a close loop amplifier configuration and the PM/LM139 as a comparator.

Presented results, primarily obtained on XMM flight lot devices, were taken using test set-ups and test conditions coming close to conditions used in the satellite. As previously reported in [1][2][3][4][5] and verified here, test set-ups, test conditions and devices tested, have a major influence on analog SET behaviour. So in the end it is the circuit design, which is the weak point if it allows microsecond spikes to switch a latch, responsible for the ‘off’ condition of a power supply.

Transient mitigation techniques have to cope with levels as measured here, with amplitudes up to rail-to-rail and duration’s approaching 4 μ s. One way of doing this is to improve the design with filter capacitors. As also shown here, often the usage of a filter capacitor of 1 to 100 nF would be sufficient.

VI. REFERENCES

- [1] R.Koga, S.D.Pinkerton, S.C.Moss, D.C. Mayer, S. LaLumondiere, S.J.Hansel, K.B.Crawford and W.R.Crain, ‘‘Observation of SEUs in Analog Microcircuits’’, IEEE Trans. on Nucl. Sci., NS-40, No. 6, Dec.’93, pp 1838-44.
- [2] R.Ecoffet, S.Duzellier, P.Tastet, C.Aicardi and M.Labrunee, ‘‘Observation of Heavy Ion Induced Transients in Linear Circuits’’, 1994 IEEE Radiation Effects Data Workshop, pp 72-77.
- [3] D.K.Nichols, J.R.Coss, T.F.Miyahira and H.R.Schwartz, ‘‘Heavy Ion and Proton Induced Single Event Transients in Comparators’’, IEEE Trans. on Nucl. Sci., NS-43, No. 6, Dec.’96, pp 2960-67.
- [4] S.H.Penzin, W.R.Crain, K.B.Crawford, S.J.Hansel, J.F.Kirshman and R.Koga, ‘‘Single Event Effects in Pulse Width Modulation Controllers’’, IEEE Trans. on Nucl. Sci., NS-43, No. 6, Dec.’96, pp 2968-73.
- [5] R.Koga, S.H.Penzin, K.B.Crawford, W.R.Crain, S.C.Moss, S.D.Pinkerton, S. D. LaLumondiere, and M.C.Maher, ‘‘Single Event Upset (SEU) Sensitivity Dependence of Linear Integrated Circuits (Ics) on Bias Conditions’’, IEEE Trans. on Nucl. Sci., NS-44, No. 6, Dec.’97, pp 2325-32.
- [6] G. Berger, G. Ryckewaert, R. Harboe Sørensen and L. Adams, ‘‘The Heavy Ion Irradiation Facility at CYCLONE - A Dedicated SEE Beam Line’’, NSREC’96, Indian Wells, California, 1996.
- [7] W. Hajdas, L. Adams, B. Nickson and A. Zehnder, ‘‘The Proton Irradiation Facility at the Paul Scherrer Institute’’ Nucl. Instr. and Meth. In Phys. Res. B113, 1996, pp 54-58.